

USER GUIDE PRD-07119

KIT-CRD-CIL17N-XM

WOLFSPEED XM HALF-BRIDGE MODULE

DYNAMIC EVALUATION BOARD USER GUIDE

半桥模块动态评估板用户指南

ハーフブリッジモジュール動的評価ボードユーザーガイド

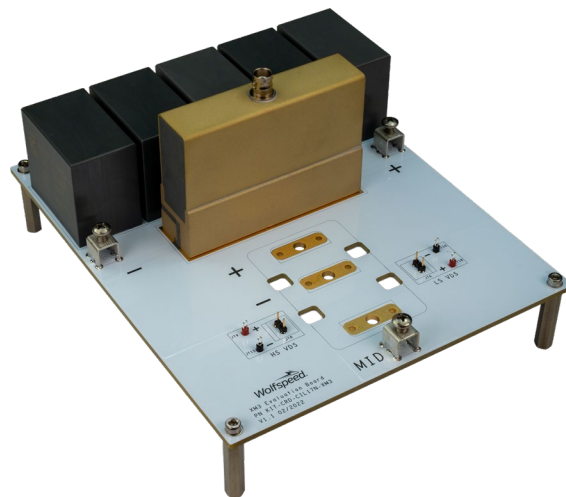

User Guide

Wolfspeed Power Applications

Wolfspeed, Inc.
4600 Silicon Drive
Durham, NC 27703, USA

沃孚半导体有限责任公司
4600 Silicon Drive
Durham, NC 27703, USA

クリー株式会社
4600 Silicon Drive
Durham, NC 27703, USA

This document is prepared as a user guide to install and operate Wolfspeed® evaluation hardware.

All parts of this user guide are provided in English, and the Cautions are provided in English, Mandarin, and Japanese. If the end user of this board is not fluent in any of these languages, it is your responsibility to ensure that they understand the terms and conditions described in this document, including without limitation the hazards of and safe operating conditions for this board.

本文件中的所有内容均以英文书写，“注意”部分的内容以英文、中文和日语书写。作为本板子的终端用户，即使您不熟悉上述任何一种语言，您也应当确保正确理解本文件中的条款与条件，包括且不限于本板子的危险隐患以及安全操作条款。

当書類のすべての内容は英語で書きます。「注意点」の内容は英語、中国語、また日本語で書きます。当ボードの端末使用者は上記の言語が一つでもわからないなら、当端末使用者は当書類の条約と条件が理解できるのを確保すべきです。そして、当ボードの危険や安全に使用する条件を含み、また限りません。

Note: This Wolfspeed-designed evaluation hardware for Wolfspeed® components is a fragile, high-voltage, high-temperature power electronics system that is meant to be used as an evaluation tool in a lab setting and to be handled and operated by highly qualified technicians or engineers. When this hardware is not in use, it should be stored in an area that has a storage temperature ranging from -40° Celsius to 105° Celsius. If this hardware is transported, to avoid any damage to electronic components, special care should be taken during transportation to avoid damaging the board or its fragile components and the board should be transported carefully in an electrostatic discharge (ESD) bag, or with ESD or shorting protection that is the same as, or similar to, the protection that is or would be used by Wolfspeed when shipping this hardware. Please contact Wolfspeed at <https://forum.wolfspeed.com/> if you have any questions about the protection of this hardware during transportation. The hardware does not contain any hazardous substances, is not designed to meet any industrial, technical, or safety standards or classifications, and is not a production-qualified assembly.

本样机（易碎、高压、高温电力电子系统）由Wolfspeed为评估其功率半导体产品而设计，用以作为在实验室环境下由专业的技术人员或工程师处理和使用的评估工具。本样机不使用时，应存储在-40°C~105°C温度范围的区域内；如需运输样机，运输过程中应该特别小心，避免损坏电路板等易碎组件。如果您对此硬件在运输之中的保护有任何疑问，请联系<https://forum.wolfspeed.com/>。样机应放置在防静电包装袋内谨慎运输，避免损坏电子组件。本样机不含任何有害物质，但其设计不符合任何工业、技术或安全标准或分类，也不是可用于生产的组件。

このクリーのコンポーネント用評価ハードウェアは壊れやすい高電圧の高温パワーエレクトロニクスシステムであり、ラボ環境での評価ツールとして使用され、優秀な技術者やエンジニアによって処理され、操作されることを意図している。ハードウェアが使用されていない場合、保管温度が-40°Cから105°Cの範囲に保管してください。このハードウェアを輸送する場合は、輸送中にボードまたはその壊れやすいコンポーネントに損傷を与えないよう特別な注意を払う必要がある。また電子部品の損傷を避けるためにボードを静電気放電(ESD)袋に静置して慎重に輸送すべき。ハードウェアの輸送中の保護について質問があれば、<https://forum.wolfspeed.com/>に連絡してください。ハードウェアには危険物質が含まれていないが、工業的、技術的、安全性の基準または分類に適合するように設計されておらず、生産適格組立品でもない。



CAUTION

PLEASE CAREFULLY REVIEW THE FOLLOWING PAGES, AS THEY CONTAIN IMPORTANT INFORMATION REGARDING THE HAZARDS AND SAFE OPERATING REQUIREMENTS RELATED TO THE HANDLING AND USE OF THIS BOARD.

警告

请认真阅读以下内容，因为其中包含了处理和使用本板子有关的危险隐患和安全操作要求方面的重要信息。

警告

ボードの使用、危険の対応、そして安全に操作する要求などの大切な情報を含むので、以下の内容をよく読んでください。



CAUTION

DO NOT TOUCH THE BOARD WHEN IT IS ENERGIZED AND ALLOW THE BULK CAPACITORS TO COMPLETELY DISCHARGE PRIOR TO HANDLING THE BOARD. THERE CAN BE VERY HIGH VOLTAGES PRESENT ON THIS EVALUATION BOARD WHEN CONNECTED TO AN ELECTRICAL SOURCE, AND SOME COMPONENTS ON THIS BOARD CAN REACH TEMPERATURES ABOVE 50° CELSIUS. FURTHER, THESE CONDITIONS WILL CONTINUE FOR A SHORT TIME AFTER THE ELECTRICAL SOURCE IS DISCONNECTED UNTIL THE BULK CAPACITORS ARE FULLY DISCHARGED.

Please ensure that appropriate safety procedures are followed when operating this board, as any of the following can occur if you handle or use this board without following proper safety precautions:

- **Death**
- **Serious injury**
- **Electrocution**
- **Electrical shock**
- **Electrical burns**
- **Severe heat burns**

You must read this document in its entirety before operating this board. It is not necessary for you to touch the board while it is energized. All test and measurement probes or attachments must be attached before the board is energized. You must never leave this board unattended or handle it when energized, and you must always ensure that all bulk capacitors have completely discharged prior to handling the board. Do not change the devices to be tested until the board is disconnected from the electrical source and the bulk capacitors have fully discharged.

警告

请勿在通电情况下接触板子，在操作板子前应使大容量电容器的电荷完全释放。接通电源后，该评估板上通常会存在危险的高电压，板子上一些组件的温度可能超过 50 摄氏度。此外，移除电源后，上述情况可能会短时持续，直至大容量电容器电量完全释放。

操作板子时应确保遵守正确的安全规程，否则可能会出现下列危险：

- 死亡
- 严重伤害
- 触电
- 电击
- 电灼伤
- 严重的热烧伤

请在操作本板子前完整阅读本文件。通电时禁止接触板子。所有测试与测量探针或附件必须在板子通电前连接。通电时，禁止使板子处于无人看护状态，且禁止操作板子。必须确保在操作板子前，大容量电容器已释放了所有电量。只有在切断板子电源，且大容量电容器完全放电后，才可更换待测试器件。

警告

通電している時、ボードに接触するのは禁止です。ボードを処分する前に、大容量のコンデンサーで電力を完全に釈放すべきです。通電してから、ボードにひどく高い電圧が存在している可能性があります。ボードのモジュールの温度は 50 度以上になるかもしれません。また、電源を切った後、上記の状況がしばらく持続する可能性がありますので、大容量のコンデンサーで電力を完全に釈放するまで待ってください。

ボードを操作するとき、正確な安全ルールを守るのを確保すべきです。さもないと、以下の危険がある可能性があります：

- 死亡
- 重症
- 感電
- 電撃
- 電気の火傷
- 厳しい火傷

当ボードを操作する前に、完全に当書類をよく読んでください。通電している時にボードに接触する必要がありません。通電する前に必ずすべての試験用のプローブあるいはアクセサリをつないでください。通電している時に無人監視やボードを操作するのは禁止です。ボードを操作する前に、大容量のコンデンサーで電力を完全に釈放するのを必ず確保してください。ボードの電源を切った後、また大容量のコンデンサーで電力を完全に釈放した後、試験設備を取り換えることができます。

CONTENTS

| | |
|-----------------------------------|----|
| Contents..... | 7 |
| Introduction..... | 8 |
| Evaluation Boards Contents | 10 |
| Current and Voltage Sensing..... | 13 |
| CVR Cabling and Termination | 14 |
| Inductor..... | 14 |
| Power Supply..... | 15 |
| Gate Driver | 19 |
| Gate Voltage Sensing..... | 19 |
| Revision History | 19 |
| IMPORTANT NOTES | 20 |
| Purposes and Use | 20 |

INTRODUCTION

This document describes in detail a clamped inductive load (CIL) test fixture designed to accurately measure the voltage and current waveforms of a Wolfspeed XM power module, shown below in Figure 1 under an inductive load switching event. This enables the calculation of switching loss energies under precise test conditions to dynamically evaluate the module and facilitate in-module comparisons and power electronic system design. During a CIL switching event, the voltage across and the current through a switch position are simultaneously present. Multiplying these two waveforms point by point results in a time-domain function of the instantaneous power in units of Watts (W). The instantaneous power has large peaks two times per switching period at the turn-on and turn-off events. The instantaneous power can then be integrated using built-in oscilloscope MATH tools or waveform data and post processing to determine the total energy lost in Joules (J) during a given switching event.



FIGURE 1: WOLFSPEED SILICON CARBIDE (SiC) XM3 HALF-BRIDGE MODULE

There are two types of switching events: actively switched (MOSFET) and forced commutation (antiparallel diode). The test fixtures to measure both events are given below in Figure 2 and Figure 3, respectively. Q1 and Q2 represent the respective switch positions of the Wolfspeed XM half-bridge power module. Likewise, D1 and D2 represent the antiparallel diodes of each switch position (the intrinsic body diode or external Schottky Diode depending on the module variant). For both tests, film capacitors (C_{BULK}) are used for bulk energy storage to provide the needed energy transfer to the inductor (L) for the switching event, while high-frequency capacitors (CHF) are used to provide a low-inductance switching loop. For MOSFET switching measurements in Figure 2, the inductor is connected across the upper switch position of the module from the midpoint to the positive bus rail while Q1 is held off and Q2 is pulsed; for body diode switching measurements in Figure 3, the inductor is connected across the lower switch position of the module to the negative bus rail while Q1 is pulsed and Q2 is held off.

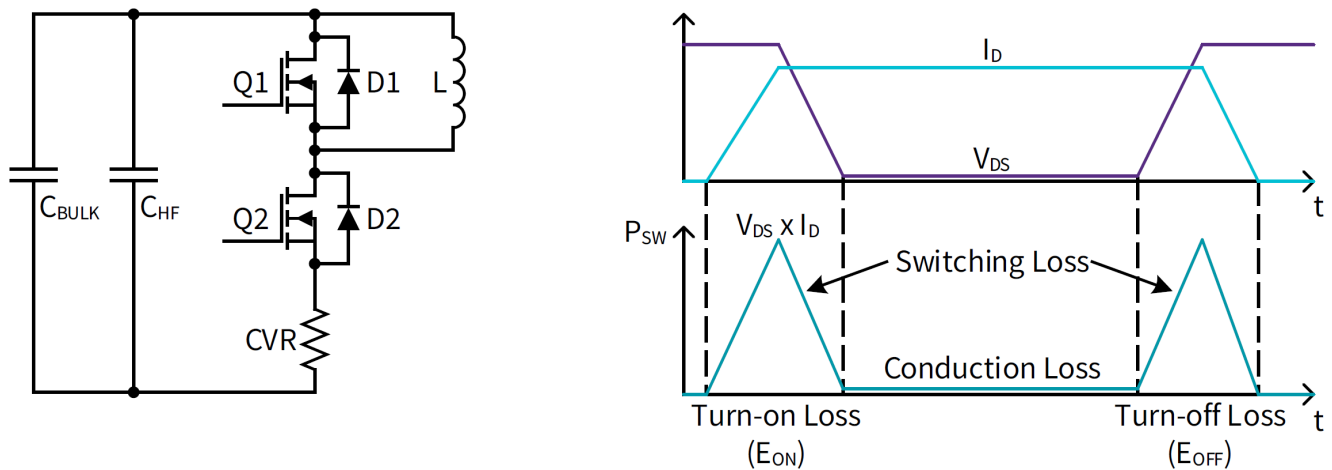

FIGURE 2: CIL TEST FIXTURE USED TO MEASURE THE SWITCHING LOSS OF MOSFET Q2 (LOW-SIDE)

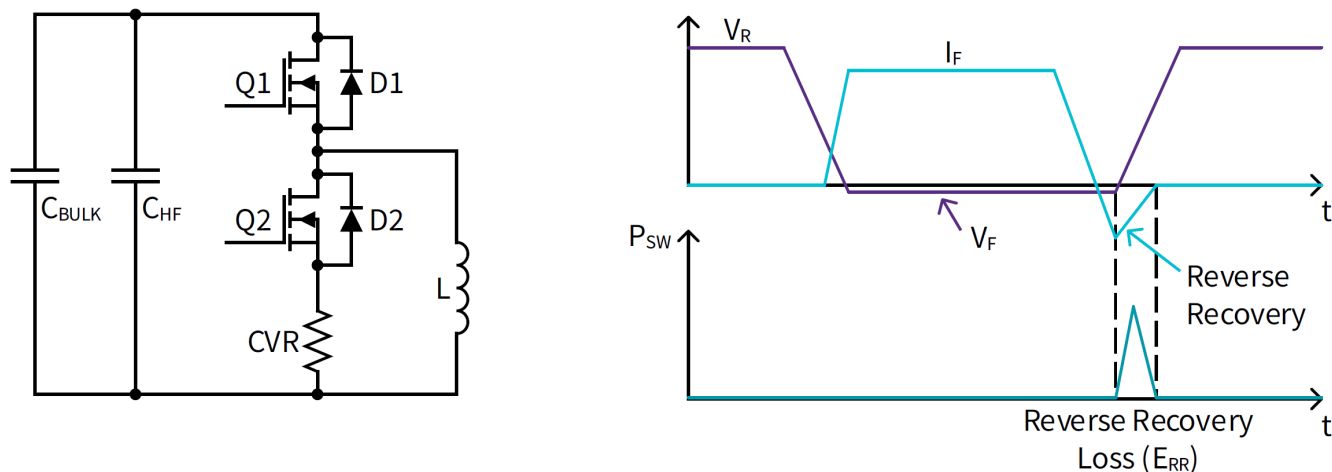

FIGURE 3: CIL TEST FIXTURE USED TO MEASURE THE SWITCHING LOSS OF ANTIPARALLEL DIODE D2¹

¹ Note: When Schottky diodes are present the “reverse recovery energy” is capacitive energy dissipated in the junction and will dissipate heat through its respective thermal path.

EVALUATION BOARDS CONTENTS



CAUTION

IT IS NOT NECESSARY FOR YOU TO TOUCH THE BOARD WHILE IT IS ENERGIZED. WHEN DEVICES ARE BEING ATTACHED FOR TESTING, THE BOARD MUST BE DISCONNECTED FROM THE ELECTRICAL SOURCE AND ALL BULK CAPACITORS MUST BE FULLY DISCHARGED.

SOME COMPONENTS ON THE BOARD REACH TEMPERATURES ABOVE 50° CELSIUS. THESE CONDITIONS WILL CONTINUE AFTER THE ELECTRICAL SOURCE IS DISCONNECTED UNTIL THE BULK CAPACITORS ARE FULLY DISCHARGED. DO NOT TOUCH THE BOARD WHEN IT IS ENERGIZED AND ALLOW THE BULK CAPACITORS TO COMPLETELY DISCHARGE PRIOR TO HANDLING THE BOARD.

PLEASE ENSURE THAT APPROPRIATE SAFETY PROCEDURES ARE FOLLOWED WHEN OPERATING THIS BOARD AS SERIOUS INJURY, INCLUDING DEATH BY ELECTROCUTION OR SERIOUS INJURY BY ELECTRICAL SHOCK OR ELECTRICAL BURNS, CAN OCCUR IF YOU DO NOT FOLLOW PROPER SAFETY PRECAUTIONS.



警告

通电时不必接触板子。连接器件进行测试时，必须切断板子电源，且大容量电容器必须释放完所有电荷。

板子上一些组件的温度可能超过 50 摄氏度。移除电源后，上述情况可能会短暂持续，直至大容量电容器完全释放电荷。通电时禁止触摸板子，应在大容量电容器完全释放电荷后，再操作电路板。

请确保在操作电路板时已经遵守了正确的安全规程，否则可能会造成严重伤害，包括触电死亡、电击伤害、或电灼伤。

警告

通电している時にボードに接触する必要がありません。設備をつないで試験する時、必ずボードの電源を切ってください。また、大容量のコンデンサーで電力を完全に釈放してください。

ボードのモジュールの温度は 50 度以上になるかもしれません。電源を切った後、上記の状況がしばらく持続する可能性がありますので、大容量のコンデンサーで電力を完全に釈放するまで待ってください。通电している時にボードに接触するのは禁止です。大容量のコンデンサーで電力をまだ完全に釈放していない時、ボードを操作しないでください。

ボードを操作している時、正確な安全ルールを守っているのを確保してください。さもなければ、感電、電撃、厳しい火傷などの死傷が出る可能性があります。

The evaluation board, shown in Figure 4, contains most of the relevant components shown in each test configuration above and provides several important features when characterizing the dynamic performance of the Wolfspeed XM power module. These features consist of bulk capacitors, high-frequency capacitors, a high bandwidth current measurement via a current viewing resistor (CVR), a Kelvin high-frequency drain-source voltage measurement via test points, and connection points for the inductor. A list of the components utilized for testing is given below in Table 1.

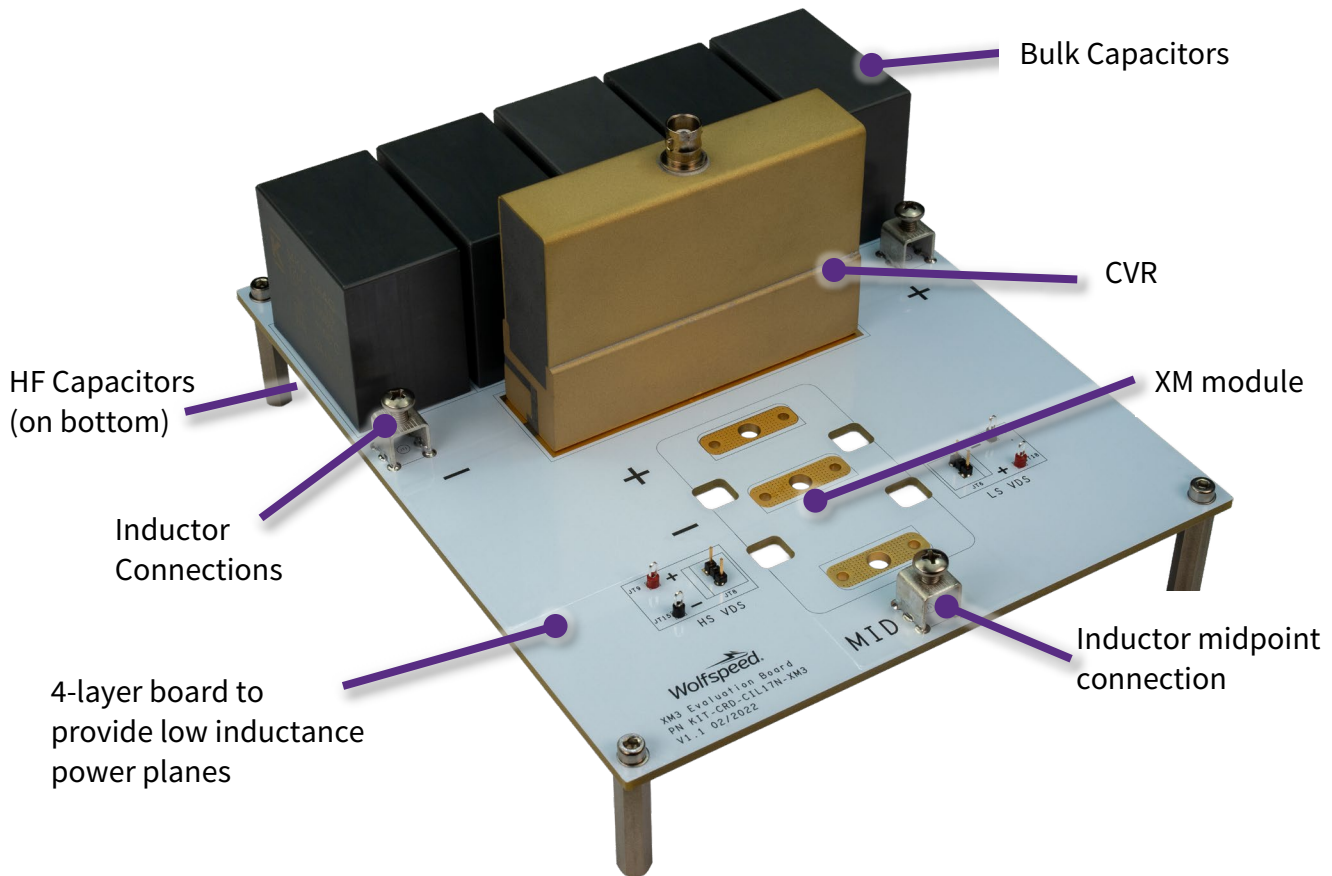

FIGURE 4: EVALUATION BOARD

TABLE 1: KIT-CRD-CIL17N-XM BILL OF MATERIALS

| Item | QTY | Description | Manufacturer | Part Number |
|------|-----|--|--------------|-----------------|
| 1 | 5 | 22 μ F, 1.5 kV, Bulk Capacitor | KEMET | C4AQSBW5220A3NJ |
| 2 | 30 | 0.047 μ F, 1.5 kV, High-Frequency Capacitors | TDK | B32022B3473M000 |
| 3 | 1 | 2.5 m Ω , 400 MHz, Current Viewing Resistor | T&M Research | W-2-0025-4FC |
| 4 | 5 | Screw Terminals, 10-32 | Keystone | 8196 |

CURRENT AND VOLTAGE SENSING

The current sensor utilized in this setup is a W Series Bar Strap Type, flat cable input CVR from T&M Research (W-2-0025-4FC), shown in Figure 5. Note that the phenolic insulator has been shortened to be flush with the resistor base. It has a bandpass of 400 MHz and a rise time of 2 ns. The large width and flat bolt-on structure allows it to be placed in the high frequency loop of the power module without introducing excessive parasitic inductance. Since the CVR is connected to the grounded oscilloscope, the polarity of the CVR must be addressed by connecting the case side of the CVR to the negative terminal of the module. This establishes a low-impedance ground connection via the CVR's BNC with a coaxial cable connected to the oscilloscope and terminated into 50 Ω . The coaxial cable should be constructed of high-quality materials. The actual measurement taken is the voltage drop across the CVR; therefore, the channel attenuation can be set to $1/\text{CVR}(\Omega)$ to get the direct current measurement. Furthermore, since the negative terminal of the module has been established as ground, with the case of the CVR connected at this point, the measured current is negative and should be inverted using the oscilloscope's MATH function to set the proper polarity.

A high bandwidth oscilloscope is required to adequately capture the fast-switching transitions of SiC MOSFETs. Before completing a CIL test, the oscilloscope and probes need to be compensated and deskewed. Compensating the voltage probe ensures that the parasitics of the probe do not cause the measure step responses to artificially appear under- or over-damped. Failure to compensate probes can result in differences in energy loss calculations, rise and fall times, and peak overshoots. Deskewing probes ensure that the channels and probes are synchronized in the time domain. Shifting waveforms in time, even by a few nanoseconds, can significantly impact overall switching loss calculations.



FIGURE 5: T&M RESEARCH W-2-0025-4FC 2.5 m Ω CVR

CVR Cabling and Termination

Although the CVR provides a high-quality measurement, it is also important to pair this with a high-quality coaxial cable for the BNC connection on the CVR. This is even more important if low-resistance CVRs are utilized, such as the one provided with this kit.

The use of low-loss coaxial cables with high-quality shields and dielectrics is recommended. High-quality cables improve measurement performance by reducing sensitivity to external stray fields. For a direct BNC measurement between the CVR and oscilloscope, a cable of similar performance to the Mini-Circuits 141-24BM+ is recommended. It features a low loss and excellent return loss with high frequency coverage. It is long enough to enable measurement without requiring the oscilloscope to be placed extremely close to the test setup and is hand-formable to reduce strain on cabling while still being capable of tight bends.

For even higher-quality measurement, a triple-shielded coaxial cable, such as the Mini-Circuits CBL-2FT-SMSM+ may be utilized. This cable is not as flexible or convenient but does provide an extremely high-quality measurement. Unfortunately, this family of precision test cables does not have an option for BNC connectors; only SMA connectors are available. Thus, an additional SMA-BNC adapter, such as the Mini-Circuits SF-BM50+, is required on both ends of the cable to interface between the CVR and oscilloscope BNC connectors.

The oscilloscope channel used to measure the CVR's voltage should also be properly configured. If directly using a 50 Ω coaxial cable between the CVR and oscilloscope, the oscilloscope termination should be set to 50 Ω to improve measurement accuracy. In an alternative configuration, an external feed-thru 50 Ω terminator, such as the Tektronix® 011-0049-02, may be plugged between the coaxial cable and the oscilloscope BNC connector with the oscilloscope termination set to 1 M Ω . This enables a similar level of accuracy but provides additional protection for the oscilloscope channel as permissible voltage ranges are typically larger for a 1 M Ω termination.

INDUCTOR

The inductor utilized for testing Wolfspeed XM3 power modules should be sized to allow enough pulse resolution (5-30 μ s depending on bus voltage) to be able to reach switched current levels in the needed range (50-900 A) without running into bandwidth or time resolution issues of the chosen controller that actuates the gate signals. Furthermore, shorter pulse durations keep the oscilloscope's measurement time range small enough (<50 μ s) to achieve the highest sample rate. The oscilloscope has a limited buffer size, so a large inductor may result in a reduced sample rate due to available memory. Keeping the current pulses short also minimizes the needed on-board bulk energy storage and limits self-heating of the die due to long conduction periods. An air-core inductor can be utilized to prevent saturation and should be shielded to prevent the magnetic field from coupling into any sensitive measurement or control signals.

POWER SUPPLY



CAUTION

IT IS NOT NECESSARY FOR YOU TO TOUCH THE BOARD WHILE IT IS ENERGIZED. WHEN DEVICES ARE BEING ATTACHED FOR TESTING, THE BOARD MUST BE DISCONNECTED FROM THE ELECTRICAL SOURCE AND ALL BULK CAPACITORS MUST BE FULLY DISCHARGED.

SOME COMPONENTS ON THE BOARD REACH TEMPERATURES ABOVE 50° CELSIUS. THESE CONDITIONS WILL CONTINUE AFTER THE ELECTRICAL SOURCE IS DISCONNECTED UNTIL THE BULK CAPACITORS ARE FULLY DISCHARGED. DO NOT TOUCH THE BOARD WHEN IT IS ENERGIZED AND ALLOW THE BULK CAPACITORS TO COMPLETELY DISCHARGE PRIOR TO HANDLING THE BOARD.

PLEASE ENSURE THAT APPROPRIATE SAFETY PROCEDURES ARE FOLLOWED WHEN OPERATING THIS BOARD AS SERIOUS INJURY, INCLUDING DEATH BY ELECTROCUTION OR SERIOUS INJURY BY ELECTRICAL SHOCK OR ELECTRICAL BURNS, CAN OCCUR IF YOU DO NOT FOLLOW PROPER SAFETY PRECAUTIONS.



警告

通电时不必接触板子。连接器件进行测试时，必须切断板子电源，且大容量电容器必须释放完所有电荷。

板子上一些组件的温度可能超过 50 摄氏度。移除电源后，上述情况可能会短暂持续，直至大容量电容器完全释放电荷。通电时禁止触摸板子，应在大容量电容器完全释放电荷后，再操作电路板。

请确保在操作电路板时已经遵守了正确的安全规程，否则可能会造成严重伤害，包括触电死亡、电击伤害、或电灼伤。

警告

通电している時にボードに接触する必要がありません。設備をつないで試験する時、必ずボードの電源を切ってください。また、大容量のコンデンサーで電力を完全に釈放してください。

ボードのモジュールの温度は 50 度以上になるかもしれません。電源を切った後、上記の状況がしばらく持続する可能性がありますので、大容量のコンデンサーで電力を完全に釈放するまで待ってください。通电している時にボードに接触するのは禁止です。大容量のコンデンサーで電力をまだ完全に釈放していない時、ボードを操作しないでください。

ボードを操作している時、正確な安全ルールを守っているのを確保してください。さもないと、感電、電撃、厳しい火傷などの死傷が出る可能性があります。

The suggested high voltage power supply utilized is a 2 kV, 150 mA, non-isolated supply from Glassman High Voltage (PS/FR2P150). This provides a low-cost solution that inherently does not have a large amount of energy storage. However, since it is non-isolated, high voltage relays are needed to open the ground loops formed due to the measurement circuitry and to charge/discharge the bulk energy storage. If ground loops are not properly removed, the resulting measurements will be significantly impacted. For safety, normally-closed relays should be used in case of a loss of control power. Furthermore, a large bleed-off resistance is connected directly across the bulk capacitors on the evaluation board PCB to slowly discharge the energy storage to a safe level. Three relays are used to create the three operating states required to complete a CIL test: CHARGE, TEST and DISCHARGE. Each operating state is further explained below. The CIL test fixture schematic with the addition of the high voltage power supply and high voltage relays is given for each respective operating state in Figure 7, Figure 8, and Figure 9.

Note that the test fixture schematic shown is for MOSFET switching analysis, but it is also applicable to body diode switching analysis where the inductor is connected across Q2.



FIGURE 6: GLASSMAN HIGH VOLTAGE PS/FR2P150 NON-ISOLATED POWER SUPPLY

CHARGE – Relay 1 and Relay 3 are CLOSED to enable charging of the bus bulk capacitors. A ground loop is formed via the non-isolated power supply return and ground reference established by the oscilloscope. Once the bus is charged, the transition to the TEST state can be made.

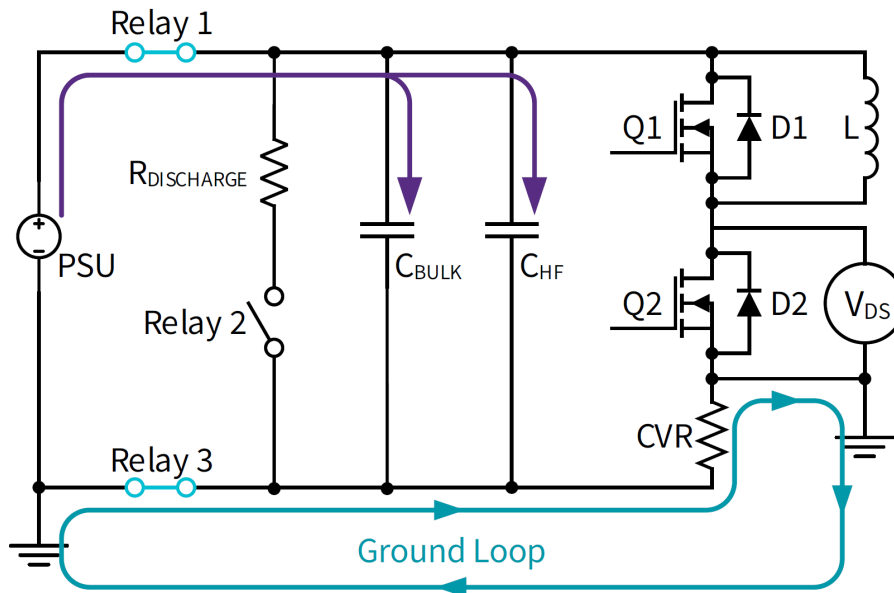

FIGURE 7: CIL TEST FIXTURE SCHEMATIC DURING THE CHARGE STATE

TEST – All relays are OPEN, removing the ground loop and referencing the test circuit to the established ground connection made via the oscilloscope. The CIL test can then be performed. Once the test is complete, the transition to the DISCHARGE state can be made, or the transition to the CHARGE state can be made to perform additional testing without discharging the bus capacitors.

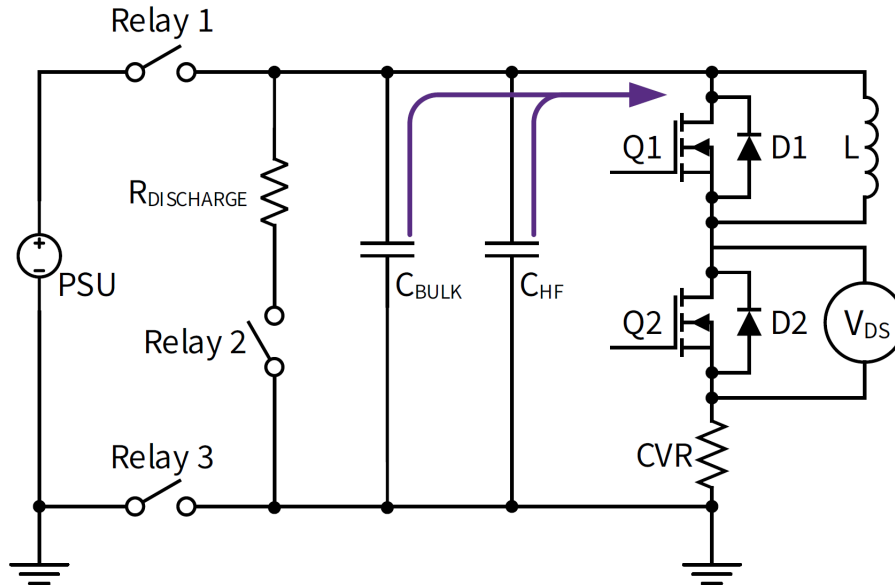

FIGURE 8: CIL TEST FIXTURE SCHEMATIC DURING THE TEST STATE.

DISCHARGE – In the final state, all relays are CLOSED to discharge the dc bus bulk capacitors and output capacitance of the high voltage power supply via the Discharge Resistor. Proper sizing of the Discharge Resistor should be considered in terms of power dissipation and the time required to discharge.

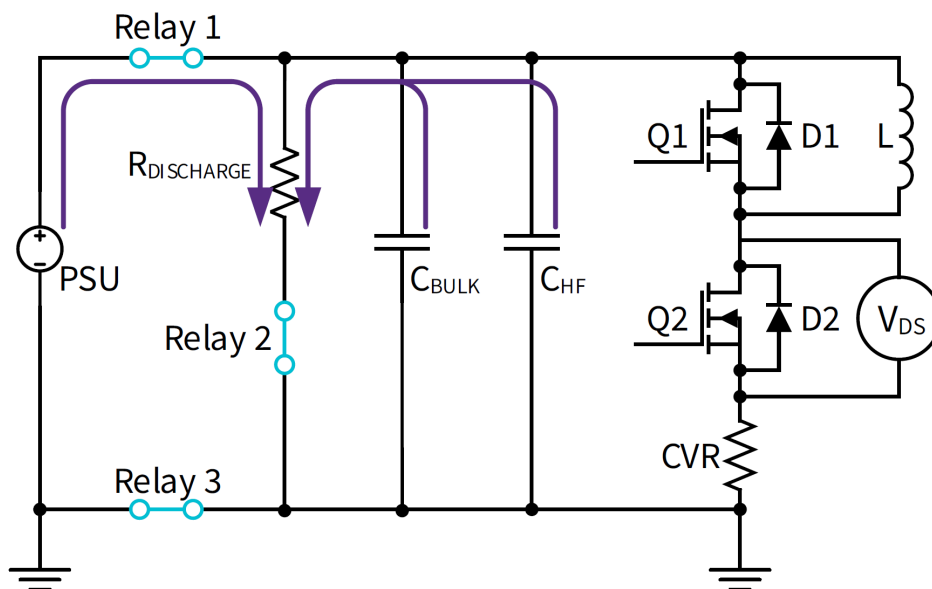

FIGURE 9: CIL TEST FIXTURE SCHEMATIC DURING THE DISCHARGE STATE

GATE DRIVER

The companion XM3 gate driver (CGD1700HB2P-XM3) is shown below in Figure 10. It is a direct mount, dual-channel isolated gate driver that is optimized for Wolfspeed’s XM3 half-bridge power module. For input/output connections and other general information regarding the use or functionality of the gate driver, please refer to the CGD1700HB2P-XM3 datasheet.

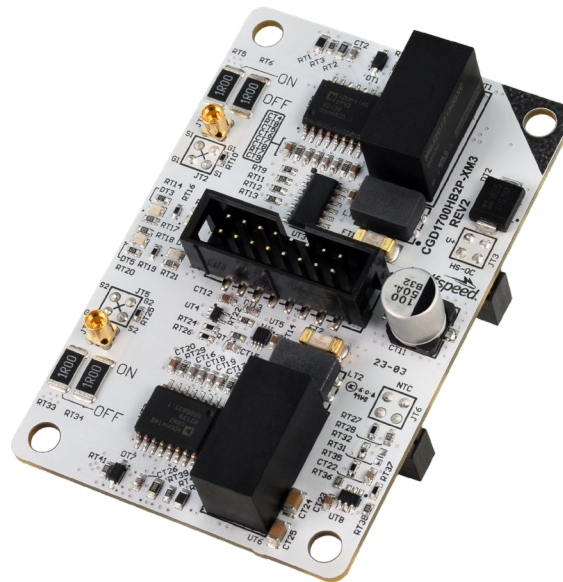

FIGURE 10: CGD1700HB2P-XM3 DUAL CHANNEL DIFFERENTIAL ISOLATED GATE DRIVER

Gate Voltage Sensing

Test points are included on the evaluation board to facilitate measuring the Gate-Source voltage for all switch positions. Standard test points for the Gate and Source terminals of all switch positions can be used with high-bandwidth, isolated differential voltage probes. An MMCX connector is also provided for a high-frequency, low-noise measurement with suitable probes such as the Tektronix® TIVP1.

REVISION HISTORY

TABLE 2: REVISION HISTORY

| Date | Revision | Changes |
|--------------|----------|-----------------------|
| January 2023 | Rev. 1 | 1 st Issue |

IMPORTANT NOTES

PURPOSES AND USE

Wolfspeed, Inc. (on behalf of itself and its affiliates, “Wolfspeed”) reserves the right in its sole discretion to make corrections, enhancements, improvements, or other changes to the board or to discontinue the board.

THE BOARD DESCRIBED IS AN ENGINEERING TOOL INTENDED SOLELY FOR LABORATORY USE BY HIGHLY QUALIFIED AND EXPERIENCED ELECTRICAL ENGINEERS TO EVALUATE THE PERFORMANCE OF WOLFSPEED POWER SWITCHING DEVICES. THE BOARD SHOULD NOT BE USED AS ALL OR PART OF A FINISHED PRODUCT. THIS BOARD IS NOT SUITABLE FOR SALE TO OR USE BY CONSUMERS AND CAN BE HIGHLY DANGEROUS IF NOT USED PROPERLY. THIS BOARD IS NOT DESIGNED OR INTENDED TO BE INCORPORATED INTO ANY OTHER PRODUCT FOR RESALE. THE USER SHOULD CAREFULLY REVIEW THE DOCUMENT TO WHICH THESE NOTIFICATIONS ARE ATTACHED AND OTHER WRITTEN USER DOCUMENTATION THAT MAY BE PROVIDED BY WOLFSPEED (TOGETHER, THE “DOCUMENTATION”) PRIOR TO USE. USE OF THIS BOARD IS AT THE USER’S SOLE RISK.

OPERATION OF BOARD

It is important to operate the board within Wolfspeed’s recommended specifications and environmental considerations as described in the Documentation. Exceeding specified ratings (such as input and output voltage, current, power, or environmental ranges) may cause property damage. If you have questions about these ratings, please contact Wolfspeed prior to connecting interface electronics (including input power and intended loads). Any loads applied outside of a specified output range may result in adverse consequences, including unintended or inaccurate evaluations or possible permanent damage to the board or its interfaced electronics. Please consult the Documentation prior to connecting any load to the board. If you have any questions about load specifications for the board, please contact Wolfspeed at forum.wolfspeed.com for assistance.

Users should ensure that appropriate safety procedures are followed when working with the board as serious injury, including death by electrocution or serious injury by electrical shock or electrical burns can occur if you do not follow proper safety precautions. It is not necessary in proper operation for the user to touch the board while it is energized. When devices are being attached to the board for testing, the board must be disconnected from the electrical source and any bulk capacitors must be fully discharged. When the board is connected to an electrical source and for a short time thereafter until board components are fully discharged, some board components will be electrically charged and/or have temperatures greater than 50° Celsius. These components may include bulk capacitors, connectors, linear regulators, switching transistors, heatsinks, resistors and SiC diodes that can be identified using board schematic. Users should contact Wolfspeed for assistance if a board schematic is not included in the Documentation or if users have questions about a board’s components. When operating the board, users should be aware that these components will be hot and could electrocute or electrically shock the user. As with all electronic evaluation tools, only qualified personnel knowledgeable in handling electronic performance evaluation, measurement, and diagnostic tools should use the board.

USER RESPONSIBILITY FOR SAFE HANDLING AND COMPLIANCE WITH LAWS

Users should read the Documentation and, specifically, the various hazard descriptions and warnings contained in the Documentation, prior to handling the board. The Documentation contains important safety information about voltages and temperatures.

Users assume all responsibility and liability for the proper and safe handling of the board. Users are responsible for complying with all safety laws, rules, and regulations related to the use of the board. Users are responsible for (1) establishing protections and safeguards to ensure that a user's use of the board will not result in any property damage, injury, or death, even if the board should fail to perform as described, intended, or expected, and (2) ensuring the safety of any activities to be conducted by the user or the user's employees, affiliates, contractors, representatives, agents, or designees in the use of the board. User questions regarding the safe usage of the board should be directed to Wolfspeed at forum.wolfspeed.com.

In addition, users are responsible for:

- compliance with all international, national, state, and local laws, rules, and regulations that apply to the handling or use of the board by a user or the user's employees, affiliates, contractors, representatives, agents, or designees.
- taking necessary measures, at the user's expense, to correct radio interference if operation of the board causes interference with radio communications. The board may generate, use, and/or radiate radio frequency energy, but it has not been tested for compliance within the limits of computing devices pursuant to Federal Communications Commission or Industry Canada rules, which are designed to provide protection against radio frequency interference.
- compliance with applicable regulatory or safety compliance or certification standards that may normally be associated with other products, such as those established by EU Directive 2011/65/EU of the European Parliament and of the Council on 8 June 2011 about the Restriction of Use of Hazardous Substances (or the RoHS 2 Directive) and EU Directive 2002/96/EC on Waste Electrical and Electronic Equipment (or WEEE). The board is not a finished end product and therefore may not meet such standards. Users are also responsible for properly disposing of a board's components and materials.

NO WARRANTY

THE BOARD IS PROVIDED "AS IS" WITHOUT WARRANTY OF ANY KIND, INCLUDING BUT NOT LIMITED TO ANY WARRANTY OF NON-INFRINGEMENT, MERCHANTABILITY, OR FITNESS FOR A PARTICULAR PURPOSE, WHETHER EXPRESS OR IMPLIED. THERE IS NO REPRESENTATION THAT OPERATION OF THIS BOARD WILL BE UNINTERRUPTED OR ERROR FREE.