

KIT12XS6EVM Evaluation Board

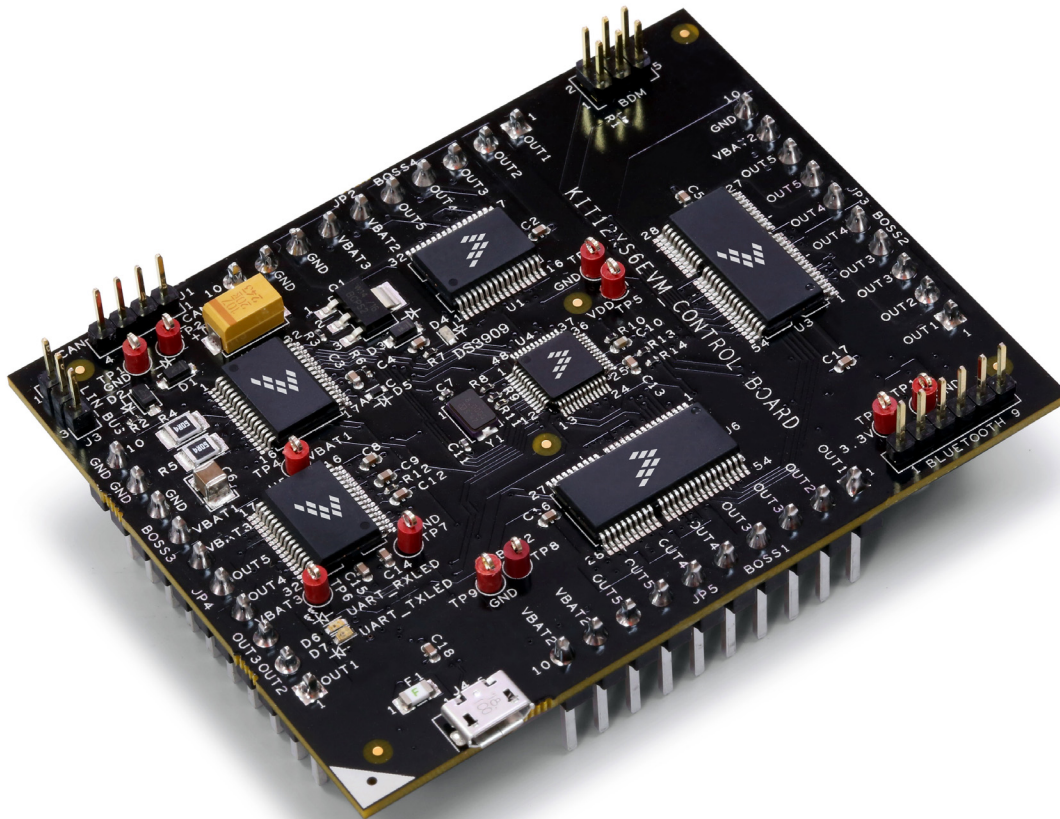

Figure 1. KIT12XS6EVM



Contents

1	Important Notice	3
2	Getting Started	4
3	Understanding the Board	5
4	Getting to Know the Hardware	7
5	Accessory KITLIGHTTEVB Load Module	12
6	Installing the Software and Setting up the Hardware	12
7	Schematic	16
8	Board Layout	19
9	Board Bill of Materials	20
10	References	22
11	Revision History	23

1 Important Notice

Freescale provides the enclosed product(s) under the following conditions:

This evaluation kit is intended for use of ENGINEERING DEVELOPMENT OR EVALUATION PURPOSES ONLY. It is provided as a sample IC pre-soldered to a printed circuit board to make it easier to access inputs, outputs, and supply terminals. This evaluation kit may be used with any development system or other source of I/O signals by simply connecting it to the host MCU or computer board via off-the-shelf cables. Final device in an application will be heavily dependent on proper printed circuit board layout and heat sinking design as well as attention to supply filtering, transient suppression, and I/O signal quality.

The goods provided may not be complete in terms of required design, marketing, and or manufacturing related protective considerations, including product safety measures typically found in the end product incorporating the goods. Due to the open construction of the product, it is the user's responsibility to take any and all appropriate precautions with regard to electrostatic discharge. In order to minimize risks associated with the customers applications, adequate design and operating safeguards must be provided by the customer to minimize inherent or procedural hazards. For any safety concerns, contact Freescale sales and technical support services.

Should this evaluation kit not meet the specifications indicated in the kit, it may be returned within 30 days from the date of delivery and will be replaced by a new kit.

Freescale reserves the right to make changes without further notice to any products herein. Freescale makes no warranty, representation or guarantee regarding the suitability of its products for any particular purpose, nor does Freescale assume any liability arising out of the application or use of any product or circuit, and specifically disclaims any and all liability, including without limitation consequential or incidental damages. "Typical" parameters can and do vary in different applications and actual performance may vary over time. All operating parameters, including "Typical", must be validated for each customer application by customer's technical experts.

Freescale does not convey any license under its patent rights nor the rights of others. Freescale products are not designed, intended, or authorized for use as components in systems intended for surgical implant into the body, or other applications intended to support or sustain life, or for any other application in which the failure of the Freescale product could create a situation where personal injury or death may occur.

Should the Buyer purchase or use Freescale products for any such unintended or unauthorized application, the Buyer shall indemnify and hold Freescale and its officers, employees, subsidiaries, affiliates, and distributors harmless against all claims, costs, damages, and expenses, and reasonable attorney fees arising out of, directly or indirectly, any claim of personal injury or death associated with such unintended or unauthorized use, even if such claim alleges that Freescale was negligent regarding the design or manufacture of the part. Freescale™ and the Freescale logo are trademarks of Freescale Semiconductor, Inc. All other product or service names are the property of their respective owners. © Freescale Semiconductor, Inc. 2015

2 Getting Started

2.1 Kit Contents/Packing List

The **KIT12XS6EVM** contents include:

- Assembled and tested evaluation board in anti-static bag
- USB cable
- Warranty card

2.2 Jump Start

Freescale's analog product development boards help to easily evaluate Freescale products. These tools support analog mixed signal and power solutions including monolithic ICs using proven high-volume SMARTMOS mixed signal technology, and system-in-package devices utilizing power, SMARTMOS and MCU dies. Freescale products enable longer battery life, smaller form factor, component count reduction, ease of design, lower system cost and improved performance in powering state of the art systems.

- Go to www.freescale.com/KIT12XS6EVM
- Look for



- Download documents, software and other information

Once the files are downloaded, review the user guide in the bundle. The user guide includes setup instructions, BOM and schematics. Jump start bundles are available on each tool summary page with the most relevant and current information. The information includes everything needed for design.

2.3 Required Equipment and Software

To use this kit, you need:

- Power supply 30 V with current up to 30 A for full performance
- Typical loads: LED or incandescent bulbs from 5.0 W to 60 W
- (Optional) KITLIGHTEVB load module
- (Optional) P&E USB BDM Multi-link Cable:
http://www.freescale.com/webapp/sps/site/prod_summary.jsp?code=USBMULTILINKBDM

2.4 System Requirements

The kit requires the following to function properly with the software:

- USB-enabled PC with Windows® XP or higher

3 Understanding the Board

This board is a full safety system that can drive the exterior lighting of a car. It consists of:

- Two MC07XS6517 (Triple 7 mΩ and Dual 17 mΩ high-side switches) for front side of the car
- 2 x MC17XS6500 (Penta 17 mΩ high-side switches) for rear side of the car
- MC33903 System basis chip for microcontroller supply, safety behavior and communication
- HCS12G128 for CAN, LIN and SPI control

This system is provided with GUI (and optional KITLIGHTTEVB) to start the board and get a quick overview of the device functions. You can check the following demonstration video for a global presentation of the system http://www.freescale.com/webapp/video_vault/videoSummary.sp?code=FTF2014_LRDFEXTREMESW_VID.

The KIT12XS6EVM contains 20 power outputs for current ranges up to 22 A DC. Microcontroller supply, safety behavior and communication with the system is managed by the embedded System Basis Chip MC33903.

3.1 Block Diagram

The high level system block diagram in Figure 2 outlines the way Freescale standard products are used to implement a full automotive lighting system.

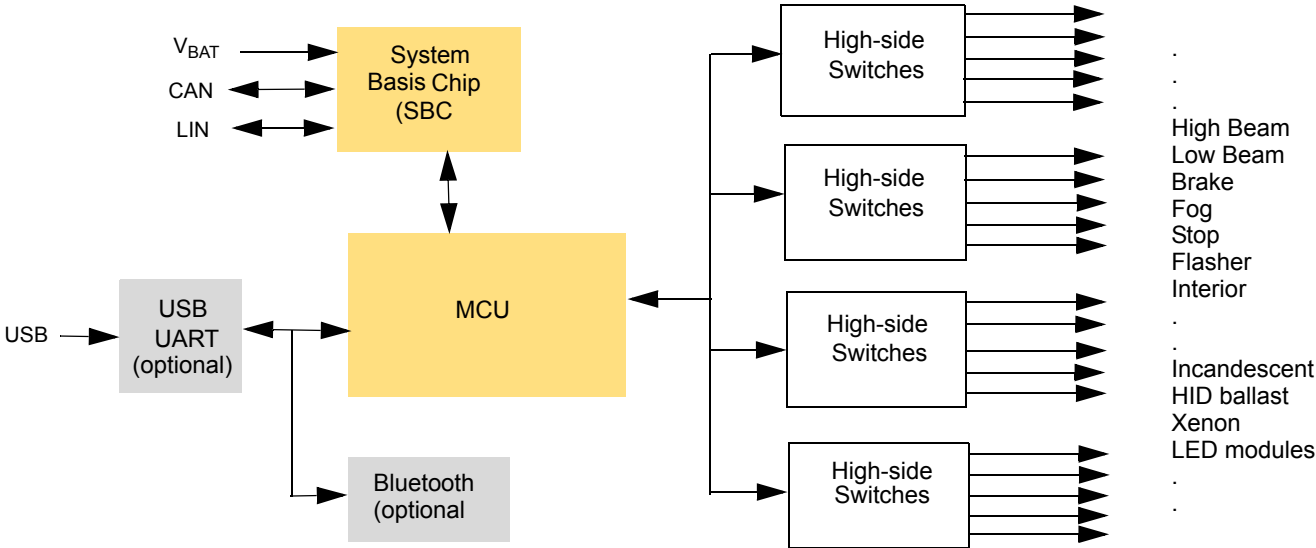

Figure 2. Block Diagram

3.1.1 Device Features

This board features the following Freescale products:

Table 1. Device Features

Device	Description	Features
S12G128	16-bit Microcontroller	<ul style="list-style-type: none"> • S12 CPU core, 25 MHz bus • Up to 240 KB on-chip flash with ECC • Up to 4.0 KB EEPROM with ECC • Up to 11 KB on-chip SRAM • Up to one multi-scalable controller area network (MSCAN) module • Supporting CAN protocol 2.0 A/B • Up to three serial communication interface (SCI) modules • Supporting LIN communications • Up to three serial peripheral interface (SPI) modules • Precision fixed voltage reference for analog-to-digital conversion (ADC) • 1 MHz internal oscillator • On-chip voltage regulator for input supply and internal voltages
MC33903	System Basis Chip Gen2 with High-speed CAN and LIN	<ul style="list-style-type: none"> • Voltage regulator for MCU, 5.0 V or 3.3 V, • Voltage, current and temperature protection • Extremely low quiescent current in low power modes • Fully-protected embedded 5.0 V regulator for the CAN driver • Multiple undervoltage detections to address various MCU specifications and system operation modes (i.e. cranking) • Auxiliary 5.0 V or 3.3 V SPI configurable regulator, for additional ICs, with overcurrent detection and undervoltage protection • Advanced SPI, MCU, ECU power supply and critical pins diagnostics and monitoring. • Multiple wake-up sources in low-power modes: CAN or LIN bus, I/O transition, automatic timer, SPI message and VDD over-current detection. • ISO11898-5 high-speed CAN interface compatibility for baud rates of 40 kb/s to 1.0 Mb/s
MC07XS6517/ MC17XS6500	Smart High-side Switches	<ul style="list-style-type: none"> • Normal operating range from 7.0 V to 18 V, extended range: 6.0 V to 28 V. • 5.0 V compatible 16-bit SPI port for device control, configuration and diagnostics at rates up to 5MHz • Individually programmable external PWM clock signals (switching frequency prescaler, duty cycle, slew rate, phase shift) • Overcurrent, short-circuit and overtemperature protection • Accurate temperature, voltage and current sensing with high precision (from 27.5 mA to 22 A) and synchronization pin • Open load detection in ON and OFF state or in LED mode • Configurable profile to fit with incandescent bulbs, LED or HID ballast (current sense ratio or over-current profiles adjusted) • Watchdog and Limp Home mode • External smart power switch control

4 Getting to Know the Hardware

4.1 Board Overview

The KIT12XS6EVM is an easy-to-use circuit board allowing the user to exercise all the functions of the MC07XS6517 and MC17XS6500 smart high-side switches. A PC links to the EVM through an onboard USB port with a Serial UART interface. A Graphical User Interface (GUI), included with the kit, allows you to communicate with the EVM for a quick overview of the device functions.

This KIT12XS6EVM comes with microcode already loaded in the S12G128's on-board flash memory. However, users who are developing a customized approach can download their own microcode to the device using the Background Debug Mode (BDM) connector.

4.2 Board Features

The key features of KIT12XS6EVM are as follows:

- 20 protected power high-side switches with low $R_{DS(on)}$ (14 x 17 m Ω + 6 x 7 m Ω)
- Normal operating range from 7.0 V to 18 V, extended range: 6.0 V to 28 V
- Background Debug Mode (BDM) connector for downloading microcode to the S12G128 on-chip flash memory
- CAN and LIN bus connectors
- Bluetooth connector with LDO voltage regulator
- USB port with Serial UART support
- Individually programmable external PWM clock signals (switching frequency prescaler, duty cycle, slew rate, phase shift)
- Overcurrent, short-circuit and overtemperature protection
- Accurate temperature, voltage, and current sensing with high precision (from 27.5 mA to 22 A)
- Open load detection in ON and OFF state or when the load is LEDs
- Configurable profile to fit with incandescent bulbs, LED or HID ballast (current sense ratio or overcurrent profiles adjusted)

4.3 Board Description

Figure 3 describes the main blocks of the KIT12XS6EVM.

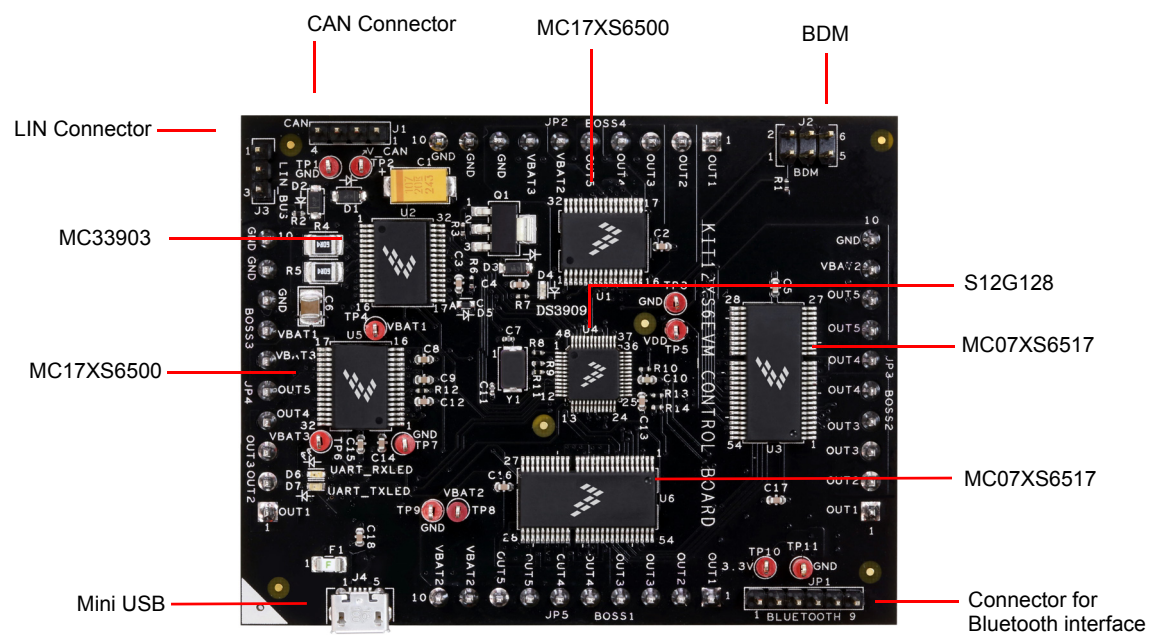

Figure 3. Board Description

Table 2. Board Description

Name	Description
2 x MC07XS6517, 2 x MC17XS6500 eXtreme switches	Four 5-channel fully protected high power high-side switches. Communication with microcontroller through SPI daisy chain. Power outputs routed to edges connectors
16-bit MCU S12G128	MCU for safety and device control
SBC MC33903	System Basis Chip with high speed CAN and LIN communication, supplies the MCU, safety management
BDM connector	Allows to flash the S12G MCU
CAN and LIN connectors	Allows to drive the board through CAN or LIN protocols
USB Connector	Mini-USB connector for GUI application
Bluetooth Connector (optional)	Plug for an external Bluetooth dongle (reference RN42-I/RM)

4.4 LED Display

The following LEDs are provided as visual output devices for the KIT12XS6EVM:

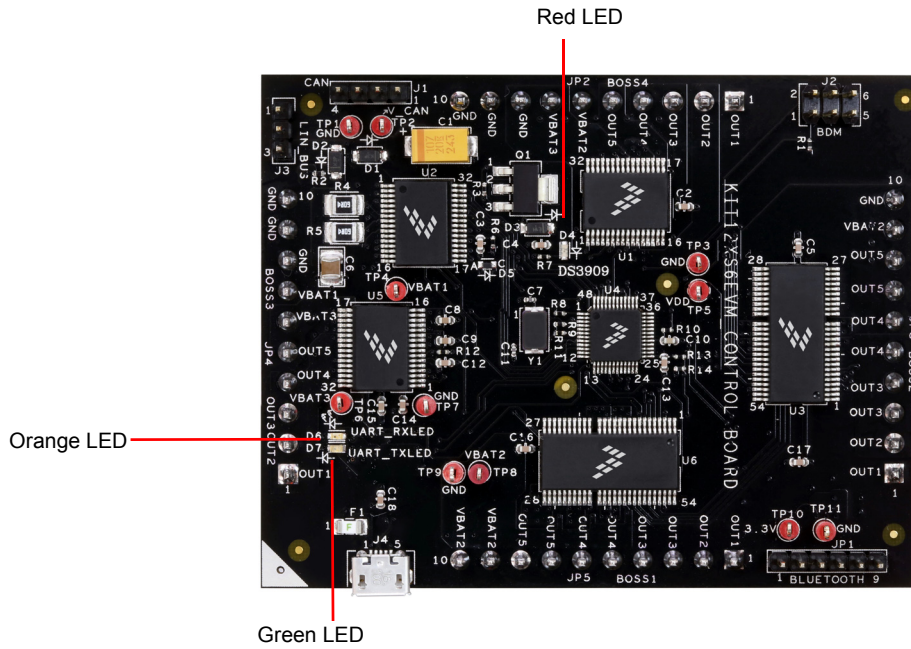

Figure 4. LED Locations

Table 3. LEDs

Label	Description
D4	Indicates the presence of the 5.0 V VDD supply (LED color: Red)
D6	Indicates the status of the UART_RX communication (LED is blinking and the color is orange when communication is OK)
D7	Indicates the status of the UART_TX communication (LED is blinking and the color is green when communication is OK)

4.5 Connectors

There are input/output connectors, which provide the following signals:

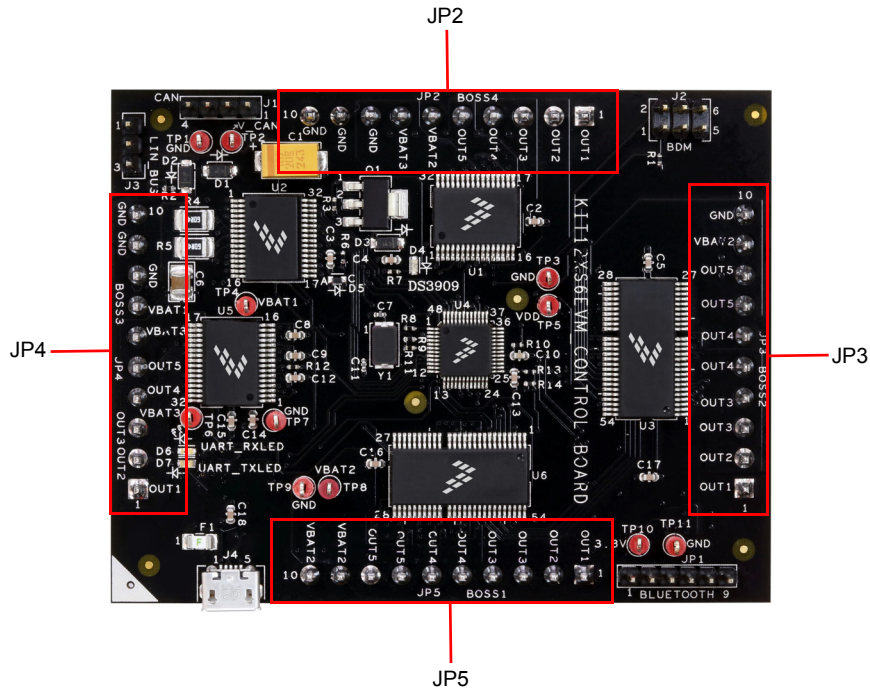

Figure 5. LED Locations

Table 4. Connector List

	JP2 Top Connector Device #4		JP3 Top Connector Device #2		JP4 Top Connector Device #3		JP5 Top Connector Device #1	
Position	Signal Name	Description	Signal Name	Description	Signal Name	Description	Signal Name	Description
1	OUT1_4	Output1 Device#4	OUT1_2	Output1 Device#2	OUT1_3	Output1 Device#3	OUT1_1	Output1 Device#1
2	OUT2_4	Output2 Device#4	OUT2_2	Output2 Device#2	OUT2_3	Output2 Device#3	OUT2_1	Output2 Device#1
3	OUT3_4	Output3 Device#4	OUT3_2	Output3 Device#2	OUT3_3	Output3 Device#3	OUT3_1	Output3 Device#1
4	OUT4_4	Output4 Device#4	OUT3_2	Output3 Device#2	OUT4_3	Output3 Device#3	OUT3_1	Output3 Device#1
5	OUT5_4	Output5 Device#4	OUT4_2	Output4 Device#2	OUT5_3	Output4 Device#3	OUT4_1	Output4 Device#1
6	VBAT3	Supply Voltage	OUT4_2	Output4 Device#2	VBAT3	Supply Voltage	OUT4_1	Output4 Device#1
7	VBAT3	Supply Voltage	OUT5_2	Output5 Device#2	VBAT1	Supply Voltage	OUT5_1	Output5 Device#1
8	GND	Ground reference	OUT5_2	Output5 Device#2	GND	Ground reference	OUT5_1	Output5 Device#1
9	GND	Ground reference	VBAT2	Supply Voltage	GND	Ground reference	VBAT2	Supply Voltage
10	GND	Ground reference	GND	Ground reference	GND	Ground reference	VBAT2	Supply Voltage

4.6 Test Point Definitions

The following test-point jumpers provide access to signals on the KIT12XS6EVM:

Table 5. Test Points

Schematic Label	Name	Description
TP1, TP3, TP7, TP9, TP11	GND	Supply Voltage
TP2	V_CAN	5.0 V CAN Voltage
TP4	VBAT1	Supply Voltage 1
TP5	VDD	5.0 V VDD Voltage
TP6	VBAT3	Supply Voltage 3
TP8	VBAT2	Supply Voltage 2
TP10	3V3	3V3 reference voltage for Bluetooth (optional)

4.7 USB Connector

A Mini-USB connector is available for communication with computer through UART protocol. Both polarities of the USB connector are connected to the FT232RQ chip to emulate Serial Communication Interface (SCI) communication. The RXD/TXD lines are directly connected to the microcontroller.

The USB connector links to the computer through a COM port in order to communicate with the GUI (the one provided with this KIT12XS6EVM, or a custom one).

5 Accessory KITLIGHTEVB Load Module

Freescall's KITLIGHTEVB provides an ideal load module for use with the KIT12XS6EVM. The KITLIGHTEVB serves as a platform for preliminary evaluation of the board and acts as a starting point for any software development on the KIT12XS6EVM.

The KITLIGHTEVB provides various types of loads that address the 20 outputs available on the KIT12XS6EVM. Those outputs are:

- Three 12 V-55/60 W H4 bulbs for high beam/low beam
- Two 12 V 21 W bulbs for parking lights, fog lights, brake lights and flashers
- Four 12 V 5/21 W bulbs for parking lights, fog lights, brake lights, flashers, parking lights and low beam
- Four 12V LED loads for parking lights, fog lights and brake lights

The KIT12XS6EVM mounts to the KITLIGHTEVB and uses the KITLIGHTEVB's high power connectors for V_{PWR} and all outputs.



Figure 6. KITLIGHTEVB Load Module

6 Installing the Software and Setting up the Hardware

6.1 Installing the GUI on your Computer

1. Download the installation file "Labview_GUI_install.zip" from www.freescall.com/KIT12XS6EVM. Unzip the file and then double-click the setup.exe file.
2. Select your destination directory and click "Next". The License Agreement box opens. Click to accept the terms of the agreement.
3. Click the Next button to start the installation program. The Installation Wizard prompts you for further actions.
4. Once the installation completes, restart your machine.
5. Launch the GUI by clicking on the "Gen4 Lighting" icon (located on your desktop or in your Start menu, depending on which option you selected during the installation.)
6. Connect USB cable and wait until the driver is installed: FT232R USB UART.

7. Go into the device manager of your computer and note the corresponding COM port associated with FT232R USB UART.
8. On the GUI (box with label 6 on the below picture), select the corresponding COM port noted in the dropdown menu.
9. If the corresponding COM port is not displayed in the box, please install following VISA driver: http://compass.freescale.net/livelink/livelink/232759628/NI_VISA_driver.zip?func=doc.Fetch&nodeid=232759628. After unzipping the file, double click on NIVISAruntime.msi to update the driver (and/or devsupport64 if x64)

6.2 Describing the GUI Interface

The Gen4 Lighting GUI allows you to:

- Display the real time Voltage on the VPWR pin of each device
- Display the real time Temperature of each device
- Display the output current for a selected channel on the oscilloscope view
- Independently turn on the 5 outputs of each of the four devices and change the duty cycle.
- Continuously refresh each device register (quick status + selectable register)
- Send specific SPI commands issued from specification
- Reset devices and the GUI

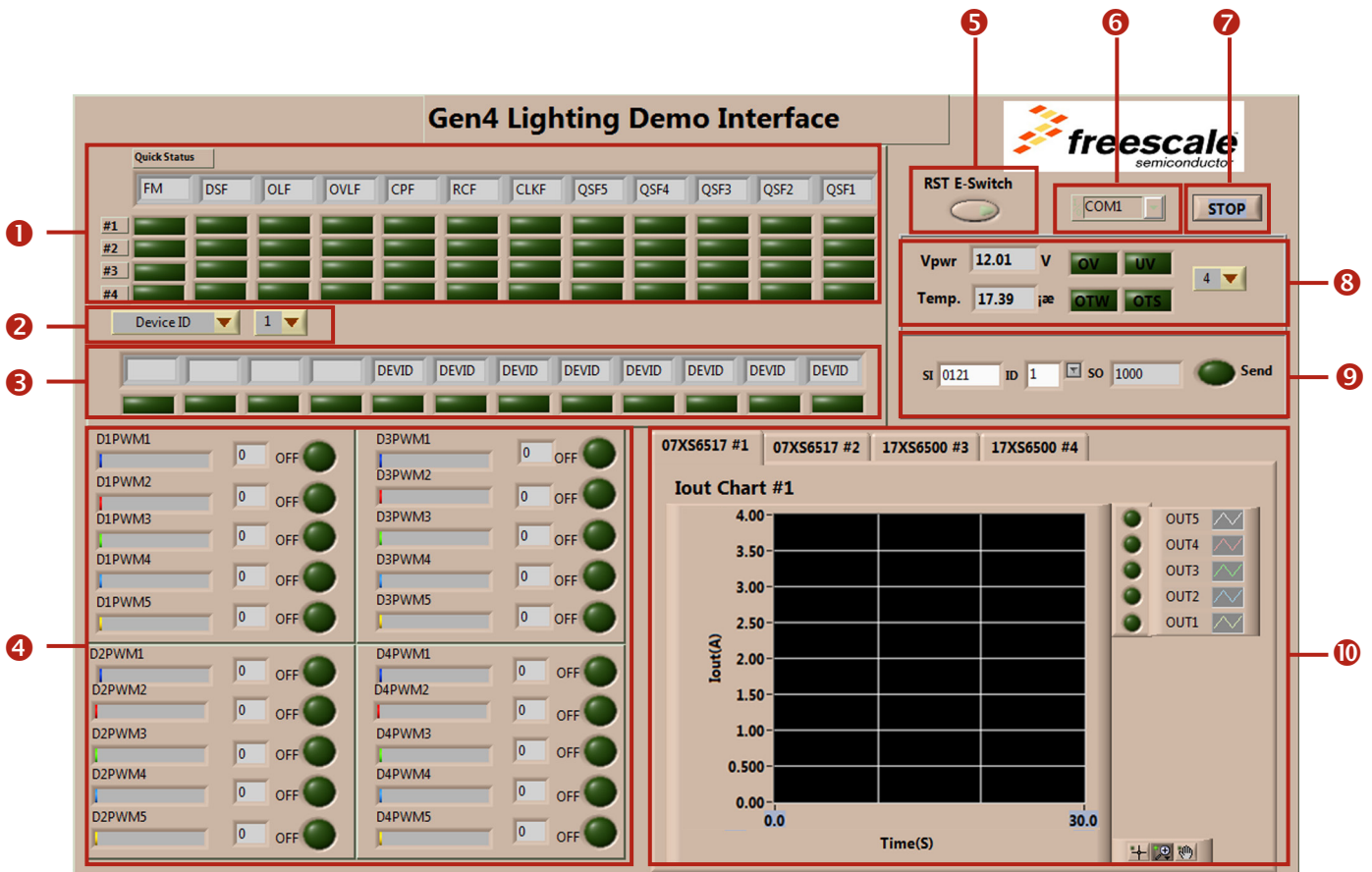

Figure 7. GUI Interface

The GUI provides a graphical view of register status and operating parameters for the four 12XS6 switches controlled by the MCU inside the KIT12XS6EVM. The GUI refers to the 12XS6's as Device number 1—4 (see Table 6 to identify the device type and board connector associated with each Device number.) The five channels on each device are also color coded from dark blue (channel1), red (channel 2), green (channel 3), light blue (channel 4), and yellow (channel 5.)

Table 6. Device Identification

Device #	Device Name	Board Connector
1	MC07XS6517EK	JP5
2	MC07XS6517EK	JP3
3	MC17XS6500EK	JP4
4	MC17XS6500EK	JP2

- 1 Quick Status Fault Reporting - Displays the Quick Status SPI Output (SPI MISO) register flags for each of the four devices. The display is continuously refreshed while the GUI is turned on.
- 2 SPI Read Register Selection - Allows you to select a device and specify which SPI Output register to display.
- 3 Register Status - Displays the status of the selected device register (Item 2.) The display refreshes each time the device register is selected.
- 4 PWM Output Control - Allows you to view and modify the duty cycle for a device/channel combination. To select a device/channel, set the ON/OFF button for that combination. The duty cycle displays as a colored bar in the box below the device/channel name and as a percentage in the box next to the button. To alter the duty cycle, click on the bar and drag it horizontally. The percentage value appears immediately above your cursor.
- 5 RST E-switch - Resets all four devices and initializes the GUI to its start-up state.
- 6 Communication Port Selection - Displays the PC COM port the GUI is communicating through. Clicking on the button in the box allows you to change the port.
- 7 GUI OFF - Clicking on the button stops GUI communication with the KIT12XS6EVM board.
- 8 Supply Voltage/Device Temperature Display - Allows you to select a device and display the supply voltage and temperature of that device. Over/undervoltage and over/undertemperature indicators turn on when the device is operating outside its voltage or temperature range. The information updates in real-time. In this implementation, when V_{PWR} voltage is less than 9.0 V, "UV" reports "1" and when V_{PWR} is greater than 16 V,"OV" reports "1".
- 9 Manual SPI Control - Allows you to enter SPI SI and SO commands as Hexadecimal values and to send the commands to a selected device.
- 10 Oscilloscope View - Allows you to select a device/channel combination and monitor its output current in real time. Controls at the lower right allow you to alter how the plot is displayed.

To select a device/channel combination for monitoring:

1. Go to the PWM Output Control panel and turn on the device/channel you wish to monitor (for instance, D3PWM4.)
2. In the oscilloscope view, click the tab corresponding to the device you selected (in this example, 17XS6500 #3.)
3. In the panel to the right of the plot screen, click on the output channel you selected (in this example, OUT4.)

Do not select more than one device/channel combination at a time.

6.3 Configuring the Hardware

Figure 8 illustrates the hardware configuration when used with the KITLIGHTEVB Load Module.

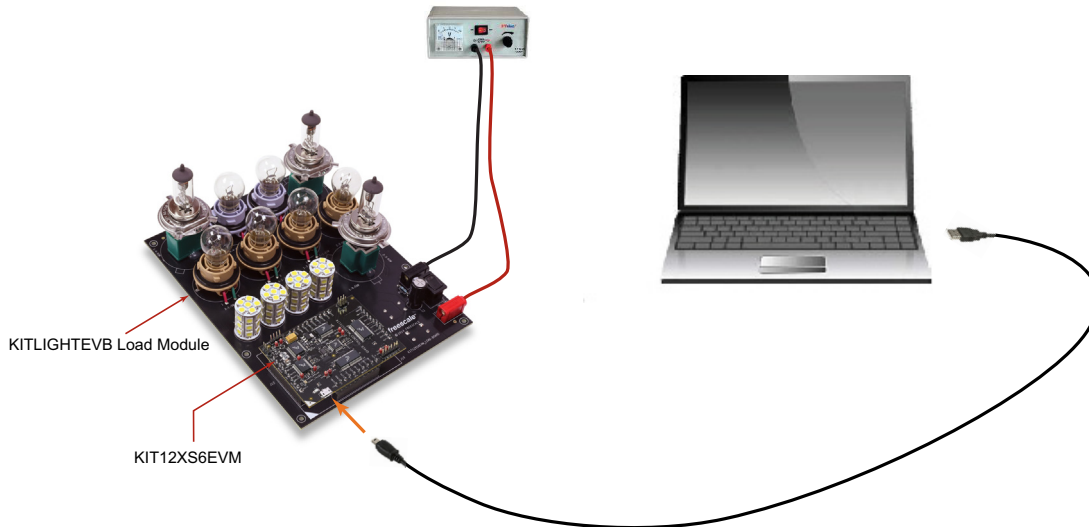

Figure 8. Board Setup

6.3.1 Step-by-step Instructions for Setting up the Hardware

The KIT12XS6EVM is designed for use with Freescale's KITLIGHTEVB evaluation module. Alternatively, you may choose to provide your own hardware to use in conjunction with the KIT12XS6EVM. The following instructions describe how to set up the KIT12XS6EVM when a KITLIGHTEVB is used as a load module. If you are using a different type of load module, consult the schematic (see [Section 7](#)) and the board descriptions (see [Section 4](#)) to determine how to connect to the KIT12XS6EVM.

1. Mount the KIT12XS6EVM board to the KITLIGHTEVB load module.
2. Insert the USB Mini-B plug into the USB port on the KIT12XS6EVM board.
3. Connect the other end of the USB cable to a PC that has the Gen4 Lighting GUI installed (See [Section 6.1](#))
4. Connect the +12 V DC power supply to the power and ground connectors on the KITLIGHTEVB board. Turn on the power supply
5. Turn on the KITLIGHTEVB module by pushing the ON/OFF switch (located between the power and ground connectors.)
6. Launch the GUI by clicking on the "Gen4 Lighting" icon (located either on your desktop or in the Program folder, depending on which option you selected during the GUI installation.)
7. If the correct COM port is not selected by default on the box under Freescale logo, associate the correct COM port as described in [Section 6.1](#). Then stop and restart the GUI (red circle and black arrow on the top left of the GUI.)

7 Schematic

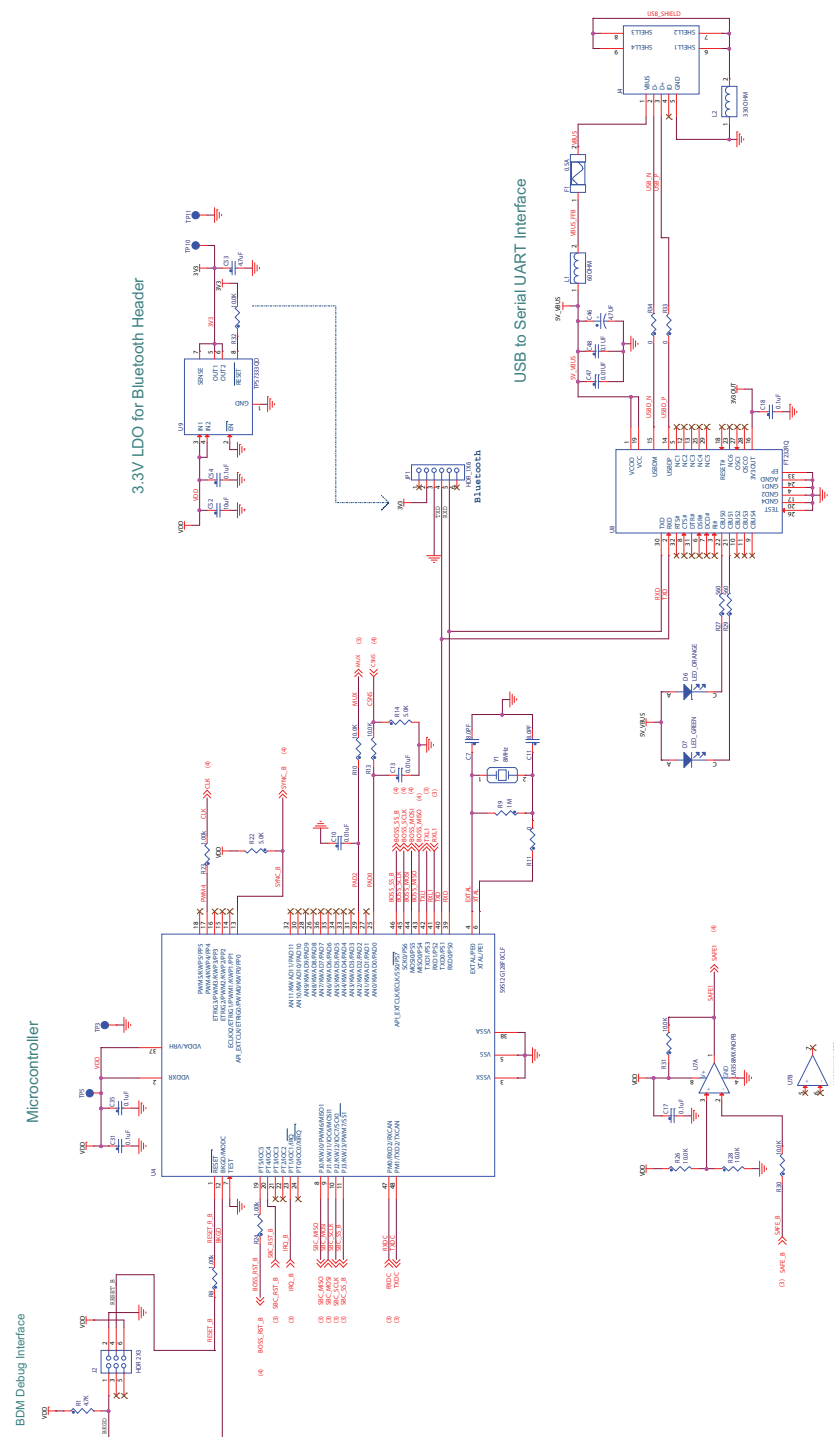

Figure 9. Schematic, Part 1

SBC with CAN High Speed and LIN Interface

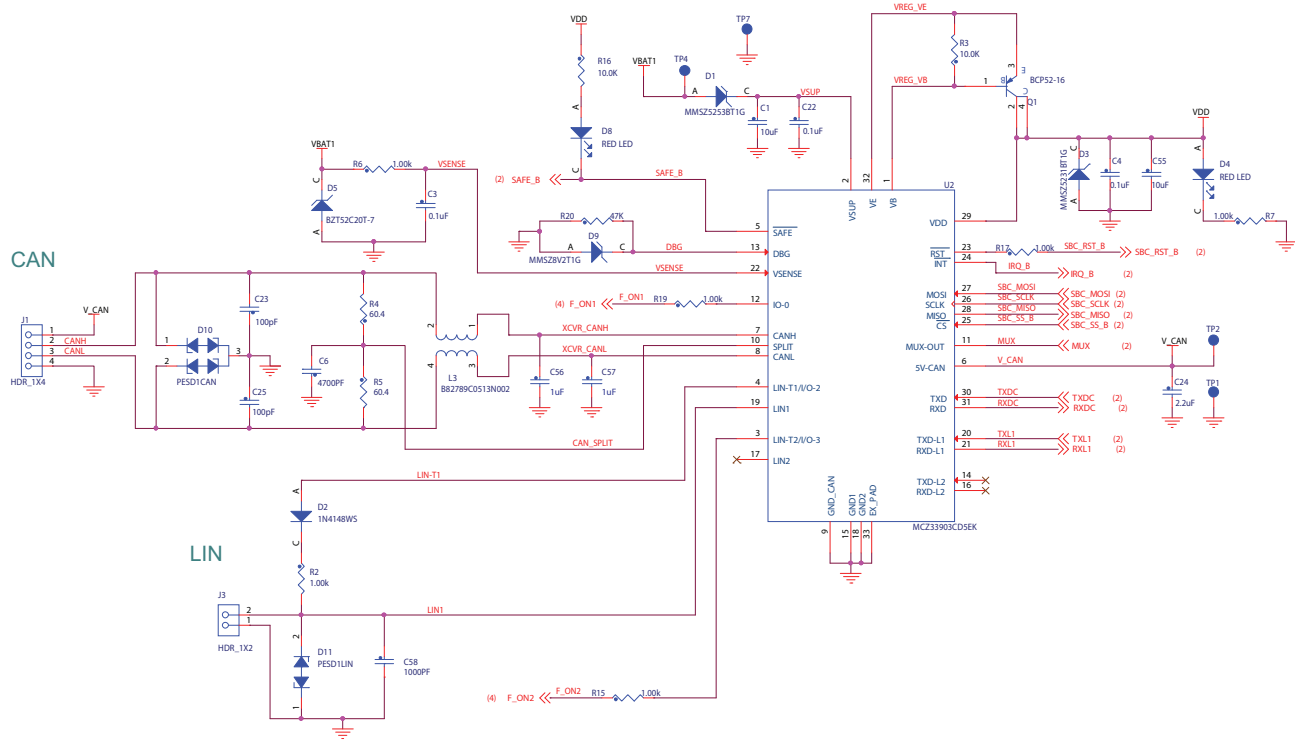

Figure 10. Evaluation Board Schematic, Part 2

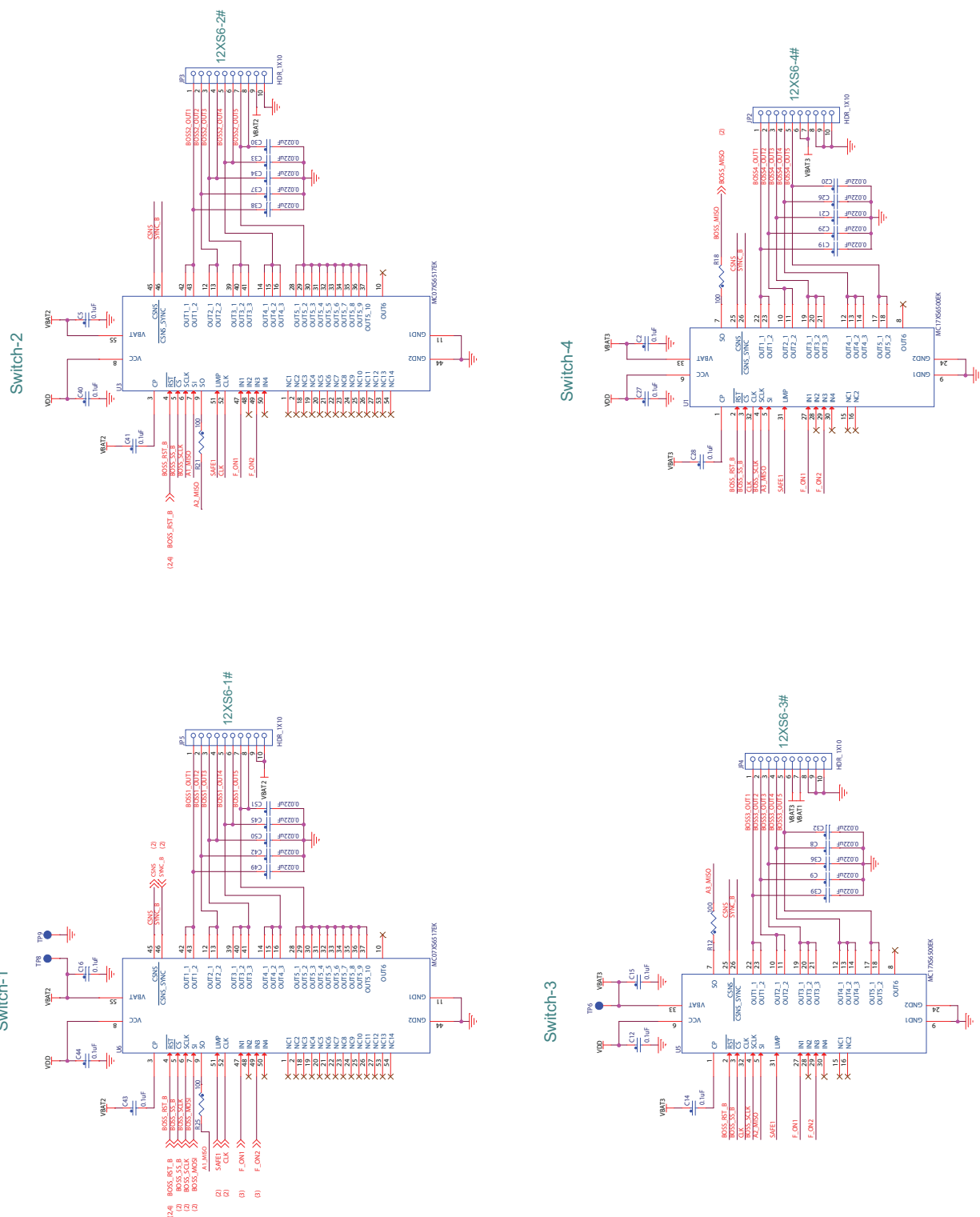

Figure 11. Schematic, Part 3

8 Board Layout

8.1 Silkscreen

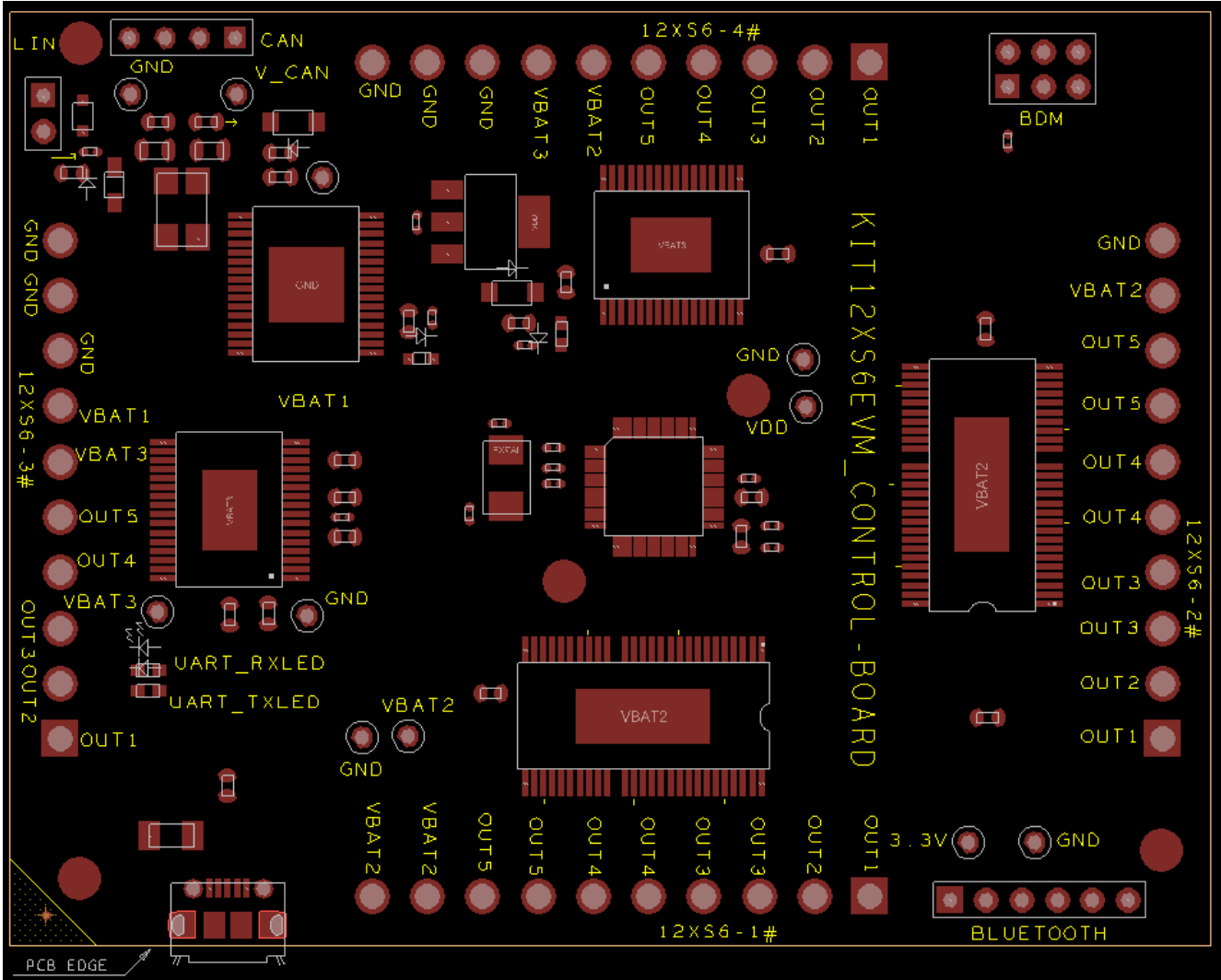

Figure 12. KIT12XF6EVM Silkscreen

9 Board Bill of Materials

Table 7. Bill of Materials⁽¹⁾

Item	Qty	Schematic label	VALUE	DESCRIPTION	Part Number
Freescale components					
1	2	U1,U5		IC SW 17 mΩ PENTA HS SOIC32	MC17XS6500EK
2	1	U2		IC XCVR CAN DUAL LIN 5.0 V 5.5-28 V AEC-Q100 SOIC32	MCZ33903CD5EK
3	2	U3,U6		IC SW TRIPLE 7 mΩ AND DUAL 17 mΩ HS 4.5-5.5 V SOIC54	MC07XS6517EK
4	1	U4		IC MCU 16 BIT 128K FLASH 8K RAM 25 MHZ 3.13-5.5 V LQFP48	S9S12G128F0CLF
Active components					
5	1	U7		IC LIN OPAMP DUAL 3-32 V SOIC8	LM358MX/NOPB
6	1	U8		IC XCVR USB TO UART CTRLR 3.3-5.25 V QFN32	FT232RQ
7	1	U9		IC VREG LDO 3.3 V 0.5 A 3.77-10 V SO8	TPS7333QD
Diodes					
8	1	D1		DIODE ZNR 25 V 0.5 W 5 mA AEC-Q101 SOD123	MMSZ5253BT1G
9	1	D2		DIODE SW 150 MA 75 V SOD-323	1N4148WS
10	1	D3		DIODE ZNR 5.1 V 0.5 W SOD123	MMSZ5231BT1G
11	2	D4,D8		LED RED SGL 30 MA SMT 0603	RED LED
12	1	D5		DIODE ZNR 20 V 300 MW SOD523	BZT52C20T-7
13	1	D6		LED OR SGL 20 MA 0603	LED_ORANGE
14	1	D7		LED GRN SGL 30 MA SMT 0603	LED_GREEN
15	1	D9		DIODE ZNR -- 0.5 W 8.2 V SOD123	MMSZ8V2T1G
16	1	D10		DIODE BIDIR CAN BUS ESD PROTECTION 200 W 24 V AEC-Q101 SOT23	PESD1CAN
17	1	D11		DIODE ESD PROTECTION 23 KV AEC-Q101 SOD323	PESD1LIN
Capacitors					
18	3	C1,C52,C55	10 μF	CAP CER 10 μF 25 V 20% X5R 0603	
19	20	C2,C3,C4,C5,C12,C14,C15,C16,C17,C18,C22,C27,C28,C31,C35,C40,C41,C43,C44,C54	0.1 μF	CAP CER 0.1 μF 25 V 10% X8R 0603	
20	1	C6	4700 PF	CAP CER 4700 PF 25 V 10% X7R 0805	
21	2	C7,C11	8.0 PF	CAP CER 8.0 PF 50 V +/- 0.5 PF C0G 0402	
22	20	C8,C9,C19,C20,C21,C26,C29,C30,C32,C33,C34,C36,C37,C38,C39,C42,C45,C49,C50,C51	0.022 μF	CAP CER 0.022 μF 50 V 10% X7R AEC-Q200 0603	
23	2	C10,C13	0.01 μF	CAP CER 0.01 μF 50 V 10% X8R 0603	
24	2	C23,C25	100 pF	CAP CER 100 pF 100 V 5% C0G 0603	
25	1	C24	2.2 μF	CAP CER 2.2 μF 25 V 10% X5R 0603	
26	1	C46	4.7 μF	CAP TANT 4.7 μF 10 V 20% -- 0603	
27	1	C47	0.01 μF	CAP CER 0.01 μF 16 V 10% X7R 0402	
28	1	C48	0.1 μF	CAP CER 0.1 μF 16 V 10% X7R 0402	
29	1	C53	4.7 μF	CAP CER 4.7 μF 16 V 10% X5R 0603	
30	2	C56,C57	1 μF	CAP CER 1 μF 25 V 10% X7R AEC-Q200 0805	
31	1	C58	1000 PF	CAP CER 1000 PF 50 V 10% C0G 0603	
Resistors					
32	1	R1	4.7 KΩ	RES MF 4.70 KΩ 1/16 W 1% 0402	
33	9	R2,R6,R7,R8,R15,R17,R19,R23,R24	1.00 KΩ	RES MF 1.00 KΩ 1/16 W 1% AEC-Q200 0402	

Table 7. Bill of Materials⁽¹⁾

Item	Qty	Schematic label	VALUE	DESCRIPTION	Part Number
34	9	R3,R10,R13,R16,R26,R28,R30,R31,R32	10.0 K Ω	RES MF 10.0 K Ω 1/16 W 1% AEC-Q200 0402	
35	2	R4,R5	60.4 Ω	RES MF 60.4 Ω 1/8 W 1% 0805	
36	1	R9	1 M Ω	RES MF 1.0 M Ω 1/16 W 1% AEC-Q200 0402	
37	3	R11,R33,R34	0 Ω	RES MF ZERO Ω 1/16 W -- AEC-Q200 0402	
38	4	R12,R18,R21,R25	100 Ω	RES MF 100 Ω 1/16 W 5% AEC-Q200 0402	
39	2	R14,R22	5.0 K Ω	RES MF 5.0 K Ω 1/16 W 5% 0402	
40	1	R20	47 K Ω	RES MF 47 K Ω 1/16 W 1% 0402	
41	2	R27,R29	560 Ω	RES MF 560 Ω 1/16 W 1% 0402	

Switches, Connectors, Jumpers and Test Points

42	1	F1	0.5 A	FUSE FAST 0.5 A 63 V SMT 1206	
43	1	JP1		HDR 1X6 TH 100MIL CTR 338H AU 150L	HDR_1X6
44	4	JP2,JP3,JP4,JP5		HDR 1X10 TH 156MIL SP 580H SN 175L	HDR_1X10
45	1	J1		HDR 1X4 TH 100MIL CTR 338H AU 200L	HDR_1X4
46	1	J2		HDR 2X3 TH 100MIL CTR 335H AU 95L	HDR_2X3
47	1	J3		HDR 1X2 TH 100MIL SP 323H AU 130L	HDR_1X2
48	1	J4		CON 5 USB_MICRO_B SKT RA SHLD SMT 0.65 MM SP 114H AU	1050170001
49	1	L1	60 OHM	IND FER BEAD 60 OHM@100 MHZ 500 MA -- 0603	
50	1	L2	330 OHM	IND FER BEAD 330 OHM@100 MHZ 2.5A -- SMT	
51	1	L3		IND CHK 2X51 UH 250 MA -30/+50% 1812	B82789C0513N002
52	1	Q1		TRAN PNP PWR 1 A 60 V SOT-223	BCP52-16
53	5	TP1,TP3,TP7,TP9,TP11	TEST POINT BLACK	TEST POINT BLACK 40 MIL DRILL 180 MIL TH 109L	
54	6	TP2,TP4,TP5,TP6,TP8,TP10	TEST POINT RED	TEST POINT RED 40 MIL DRILL 180 MIL TH 109L	
55	1	Y1	8 MHz	XTAL 8 MHZ -- -- SMT	

Notes

1. Freescale does not assume liability, endorse, or warrant components from external manufacturers are referenced in circuit drawings or tables. While Freescale offers component recommendations in this configuration, it is the customer's responsibility to validate their application.

10 References

Following are URLs where you can obtain information on related Freescale products and application solutions:

Freescale.com Support Pages	Description	URL
KIT12XS6EVM	Tool Summary Page	www.freescale.com/KIT12XS6EVM
KITLIGHTEVB	Tool Summary Page	www.freescale.com/KITLIGHTEVB
MC33903	Product Summary Page	http://www.freescale.com/webapp/sps/site/prod_summary.jsp?code=MC33903
MC07XS6517	Product Summary Page	http://www.freescale.com/webapp/sps/site/prod_summary.jsp?code=MC12XS6
MC17XS6500	Product Summary Page	http://www.freescale.com/webapp/sps/site/prod_summary.jsp?code=MC12XS6
S12G	Product Summary Page	http://www.freescale.com/webapp/sps/site/prod_summary.jsp?code=S12G
USBMULTILINKBDM	Tool Summary Page	http://www.freescale.com/webapp/sps/site/prod_summary.jsp?code=USBMULTILINKBDM

10.1 Support

Visit www.freescale.com/support for a list of phone numbers within your region.

10.2 Warranty

Visit www.freescale.com/warranty to submit a request for tool warranty.

11 Revision History

Revision	Date	Description of Changes
1.0	10/2015	<ul style="list-style-type: none"> • Initial release