

Using the High Input Voltage Charger for Single Cell Li-Ion Batteries (KIT34671EPEVBE)

1 Purpose

This User Guide helps the Lithium-Ion (Li-Ion) battery charger designer understand the MC34671 and its evaluation board. It illustrates the design procedure when using the MC34671 to design a Li-Ion battery charger, and the way to get the best performance from the MC34671.

2 Scope

The MC34671 is a low-cost high input voltage linear charger for single cell Li-Ion batteries in a tiny 2x3mm UDFN package. It features high accuracy output voltage and charge current. Its high input voltage of 28V eliminates the over-voltage protection circuit required in handheld devices. It uses an external resistor to set the CC-mode charge current up to 600mA. The end of charge (EOC) current is preset to 10% of the CC-mode charge current by the factory. When the battery voltage is below the trickle charge threshold of 2.7V, the MC34671 charges the battery with 20% of the CC-mode charge current. Three indication pins

Contents

1 Purpose	1
2 Scope	1
3 Application Diagram	2
4 Evaluation Board Specification	3
5 Component Selection	5
6 Layout Design	6
7 Evaluation Board Configuration	8
8 Test Setup with the Evaluation Board	10
9 References	12

($\overline{\text{PPR}}$, $\overline{\text{CHG}}$, and $\overline{\text{FAST}}$) can be simply interfaced to the system or LEDs to report the charge status. Its internal thermal foldback control reduces the charge current automatically, whenever the die temperature reaches the thermal limit threshold of 110°C, to keep the charger safe. When there is no input power, or when the MC34671 is disabled, the charger draws less than a 1.0µA leakage current from the battery.

3 Application Diagram

3.1 Standalone Charger

The MC34671 can be used as a standalone Li-Ion charger. **Figure 1** is the typical application circuit. Two LEDs indicate the charge status.

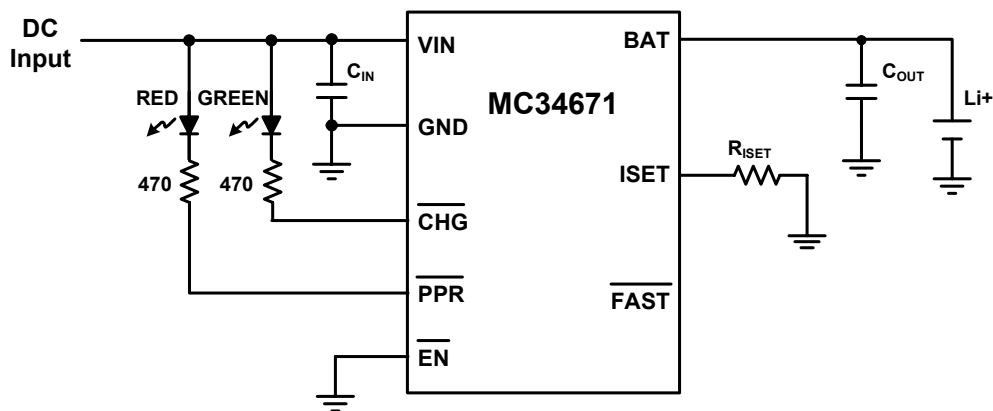

Figure 1. The Standalone Li-Ion Charger

3.2 Embedded Charger

When the MC34671 is embedded in the system, the system MCU can control the charger through the EN pin and get the charge status through PPR, CHG, and FAST pins. **Figure 2** is the typical application circuit.

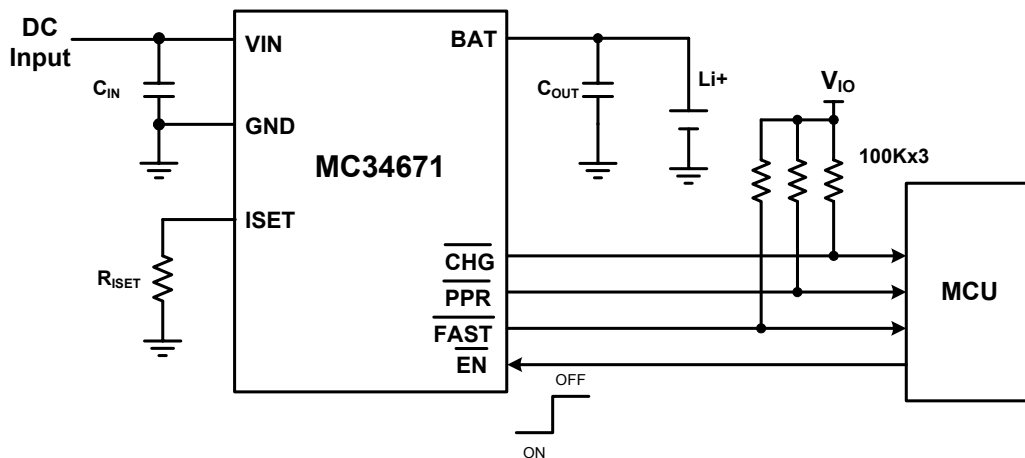

Figure 2. The Li-Ion Charger Embedded in the Hand Held System

4 Evaluation Board Specification

The evaluation board is designed to work as a standalone charger, or as an embedded charger in a handheld system. **Figure 3** shows its schematic circuit. **Table 1** is the BOM list of the evaluation board. The normal operation range of the evaluation board is:

$$V_{IN_MIN} = 4.3V, V_{IN_MAX} = 11V$$

$$I_{CHG_MAX} = 600mA$$

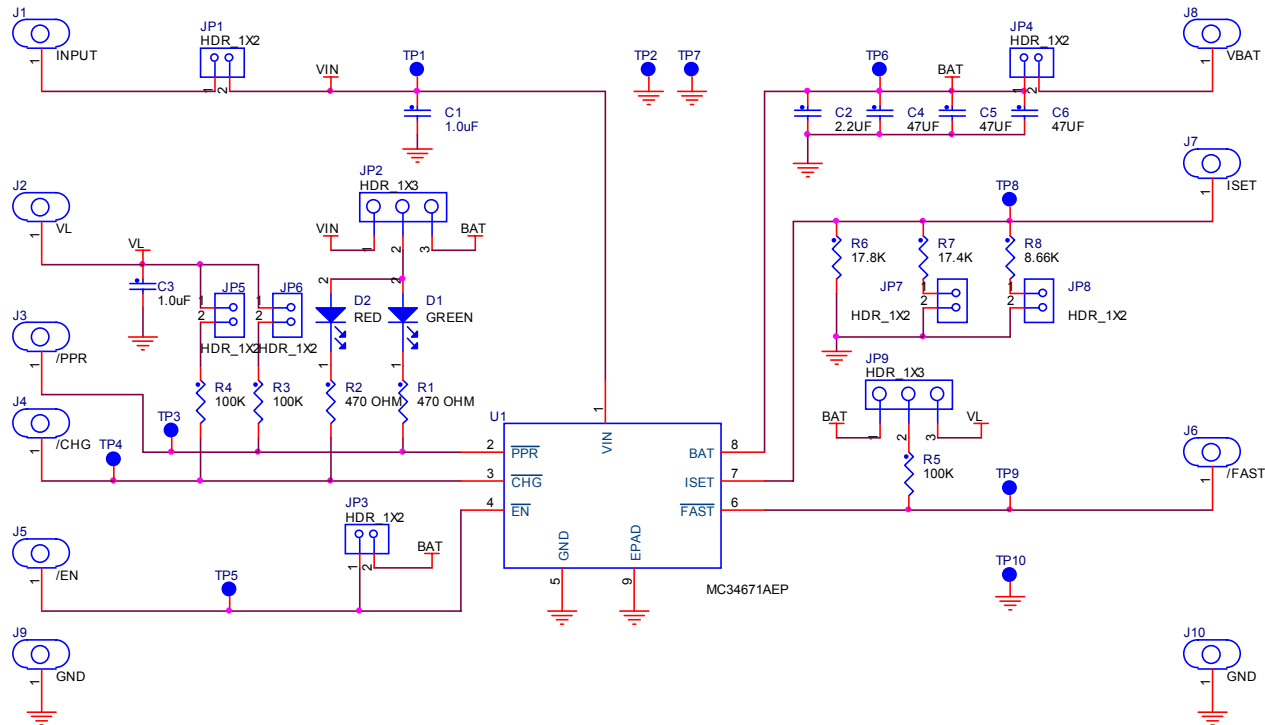

Figure 3. The Schematic Circuit of the Evaluation Board

Table 1. The Components on the Evaluation Board

Designator	Footprint	Part Value	Part Number	Description	Vendor
C1	CC0603	1.0 μ F	C1608X5R1C105K	16V, X5R ceramic, 10%	TDK
C2	CC0603	2.2 μ F	C1608X5R1C225K	6.3V, X5R ceramic, 10%	TDK
C3	CC0603	1.0 μ F	C1608X5R1C105K	16V, X5R ceramic, 10%	TDK
C4	CC1206	47 μ F	C3216X5R0J476M	6.3V, X5R ceramic, 20%	TDK
C5	CC1206	47 μ F	C3216X5R0J476M	6.3V, X5R ceramic, 20%	TDK
C6	CC1206	47 μ F	C3216X5R0J476M	6.3V, X5R ceramic, 20%	TDK
R1	RC0603	470	CR0603JW471E	MF, 5%, 1/10W	BOURNS
R2	RC0603	470	CR0603JW471E	MF, 5%, 1/10W	BOURNS

Table 1. The Components on the Evaluation Board

Designator	Footprint	Part Value	Part Number	Description	Vendor
R3	RC0603	100K	CR0603-JW-104ELF	MF, 5%, 1/10W	BOURNS
R4	RC0603	100K	CR0603-JW-104ELF	MF, 5%, 1/10W	BOURNS
R5	RC0603	100K	CR0603-JW-104ELF	MF, 5%, 1/10W	BOURNS
R6	RC0603	17.8K	RK73H1JTDD1782F	MF, 1%, 1/10W	KOA SPEER
R7	RC0603	17.4K	RK73H1JTDD1742F	MF, 1%, 1/10W	KOA SPEER
R8	RC0603	8.66K	RK73H1JTDD8661F	MF, 1%, 1/10W	KOA SPEER
D1	LED0603	GREEN	LTST-C190KGKT	Ultra-bright Green LED	LITE ON
D2	LED0603	RED	LTST-C190KRKT	Ultra-bright Red LED	LITE ON
TP1	TP	VIN	TP-105-01-00	Test Point	COMPONENTS
TP2	TP	GND	TP-105-01-00	Test Point	COMPONENTS
TP3	TP	$\overline{\text{PPR}}$	TP-105-01-00	Test Point	COMPONENTS
TP4	TP	$\overline{\text{CHG}}$	TP-105-01-00	Test Point	COMPONENTS
TP5	TP	$\overline{\text{EN}}$	TP-105-01-00	Test Point	COMPONENTS
TP6	TP	BAT	TP-105-01-00	Test Point	COMPONENTS
TP7	TP	GND	TP-105-01-00	Test Point	COMPONENTS
TP8	TP	ISET	TP-105-01-00	Test Point	COMPONENTS
TP9	TP	$\overline{\text{FAST}}$	TP-105-01-00	Test Point	COMPONENTS
TP10	TP	GND	TP-105-01-00	Test Point	COMPONENTS
JP1	HDR102	2-PIN	826629-2	TH 100MIL SP 375H	TYCO
JP2	HDR103	3-PIN	826629-3	TH 100MIL SP 375H	TYCO
JP3	HDR102	2-PIN	826629-2	TH 100MIL SP 375H	TYCO
JP4	HDR102	2-PIN	826629-2	TH 100MIL SP 375H	TYCO
JP5	HDR102	2-PIN	826629-2	TH 100MIL SP 375H	TYCO
JP6	HDR102	2-PIN	826629-2	TH 100MIL SP 375H	TYCO
JP7	HDR102	2-PIN	826629-2	TH 100MIL SP 375H	TYCO
JP8	HDR102	2-PIN	826629-2	TH 100MIL SP 375H	TYCO
JP9	HDR103	3-PIN	826629-3	TH 100MIL SP 375H	TYCO
U1	2x3 UDFN-8		MC34671AEP	Single Cell Li+ Battery Charger IC, Linear	FREESCALE

Freescale does not assume liability, endorse, or warrant components from external manufacturers that are referenced in circuit drawings or tables. While Freescale offers

component recommendations in this configuration, it is the customer’s responsibility to validate their application.

5 Component Selection

5.1 Input capacitor C1

The input capacitor is used to minimize the input voltage transient that may cause instability. A ceramic capacitor of 1.0μF or above is required for most applications. X5R and X7R dielectrics have better temperature stability. The evaluation board uses 1.0μF X5R ceramic capacitors. Considering the maximum input voltage rating of the MC34671 is 28V, the input capacitor must have 16V DC rated voltage.

5.2 Output capacitors C2, C4, C5, and C6

The output capacitor is used for stable operation. A ceramic capacitor minimum of a 2.2μF is required. On the evaluation board, a C2 of 2.2μF is necessary. The large capacitors of C4, C5, and C6 are used to simulate the situation in the cell phone application where big capacitance is put in parallel with the Li-Ion battery. The user may remove C4, C5, and C6 if their system doesn’t need such large capacitance. C4, C5, and C6 do not affect the performance of the MC34671. Because the highest output voltage of the MC34671 is 4.2V, a 6.3V DC rated voltage is high enough for the output capacitors.

5.3 Charge current setting resistors R6, R7, and R8

The resistor between the ISET pin and GND sets the charge current by the following equation:

$$I_{CHG} = 2667 / (R_{ISET} + 96) \text{ (A)}$$

where R_{ISET} is in units of Ω , I_{CHG} is in units of amps. A metal film with a 1% tolerance resistor should be used for temperature stability. As a result, the charge current will be accurate over the whole temperature range.

On the evaluation board, three resistors with two pin header jumpers are used for the user to conveniently configure different charge current values. [Table 2](#) shows the charge current with the different settings of pin headers JP7 and JP8.

Table 2. The Charge Current Settings

JP7	JP8	Charge Current
Open	Open	150mA
Short	Open	300mA
Open	Short	450mA
Short	Short	600mA

6 Layout Design

6.1 Layout

The KIT34671EPEVBE PCB board has two copper layers. The component side of the KIT34671EPEVBE is provided to locate all components. **Figure 4** is an overview of the board, followed by the layout of each layer.

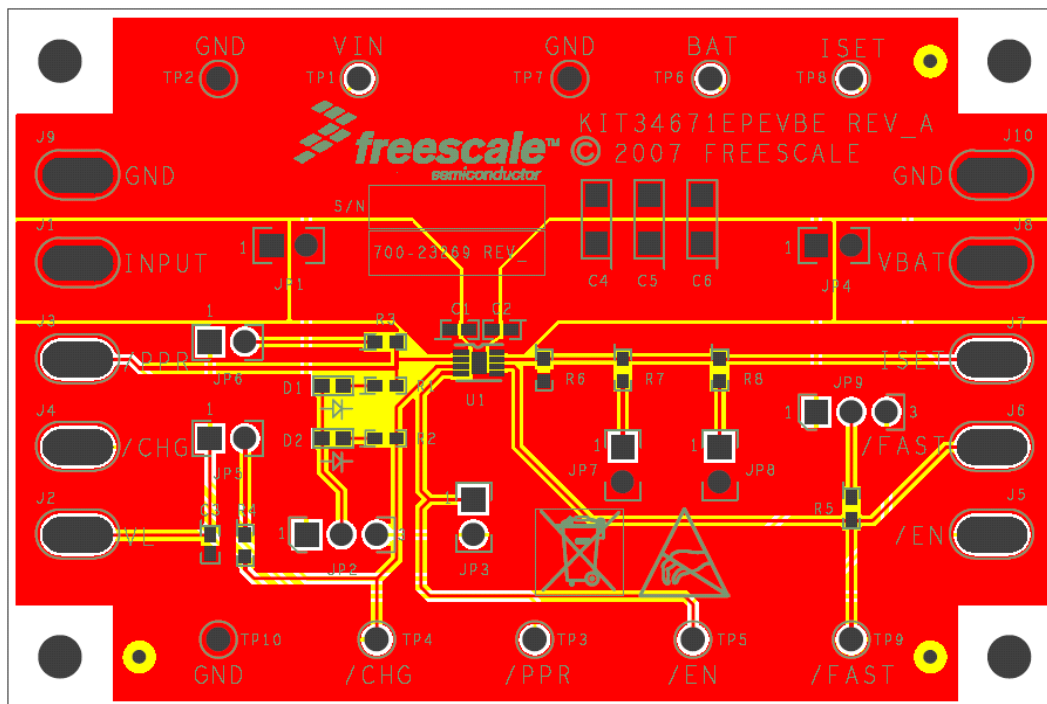

Figure 4. The Overview of the Evaluation Board

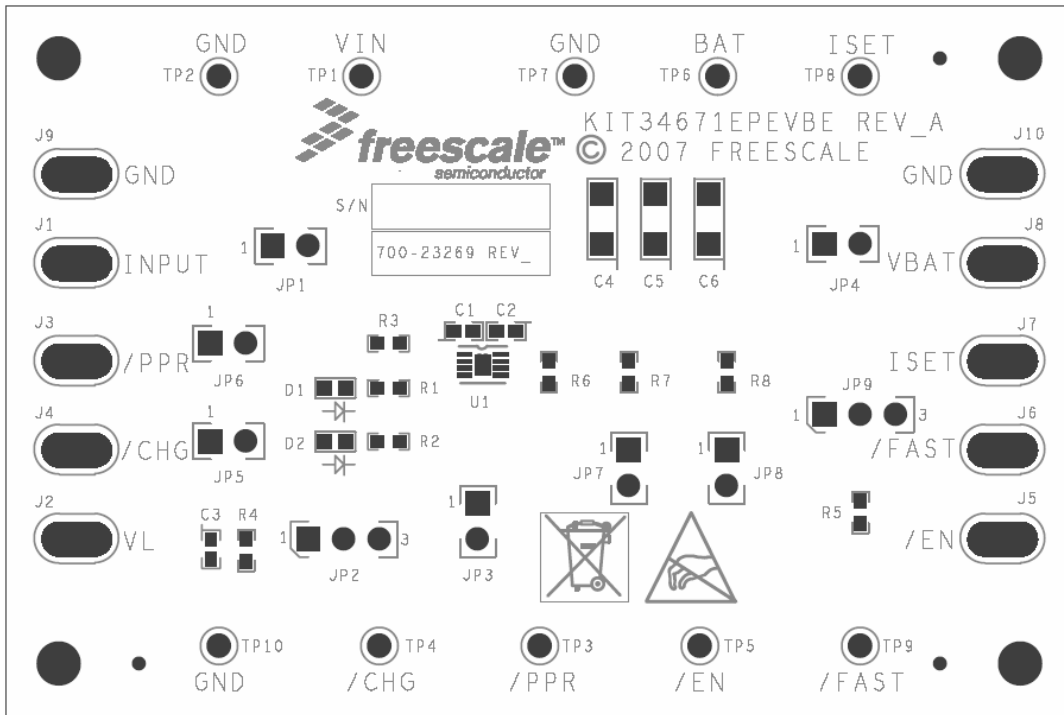

Figure 5. The Silkscreen Layer of the Evaluation Board

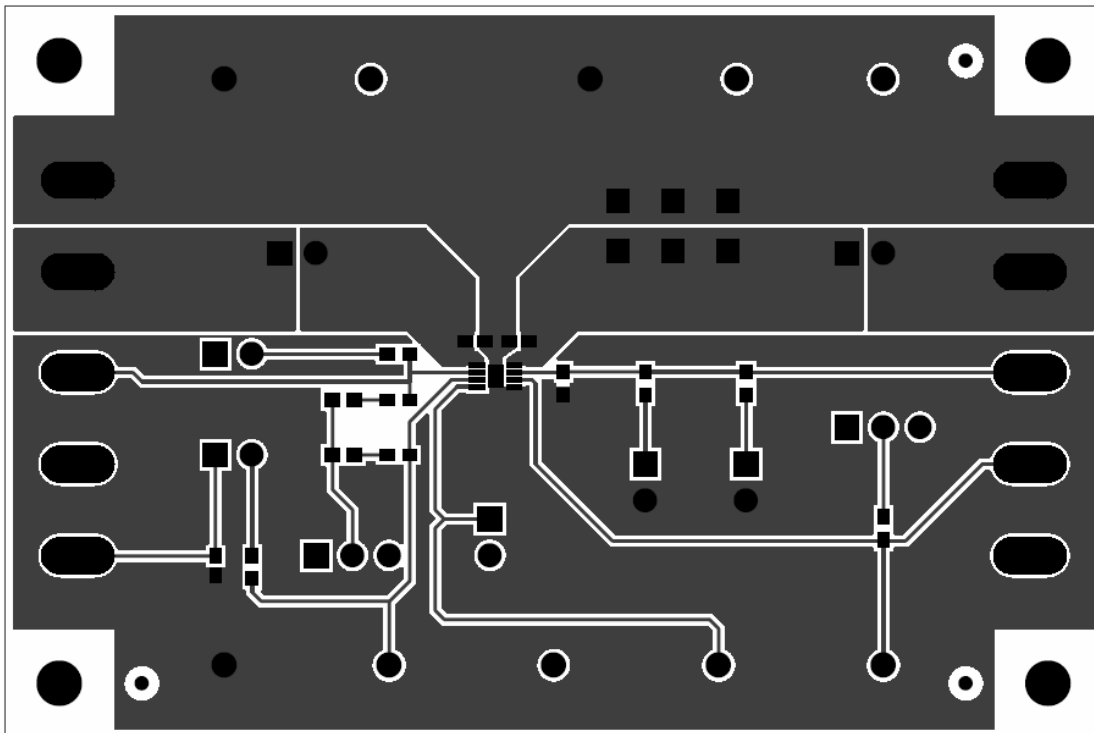

Figure 6. The Component Side Layer of the Evaluation Board

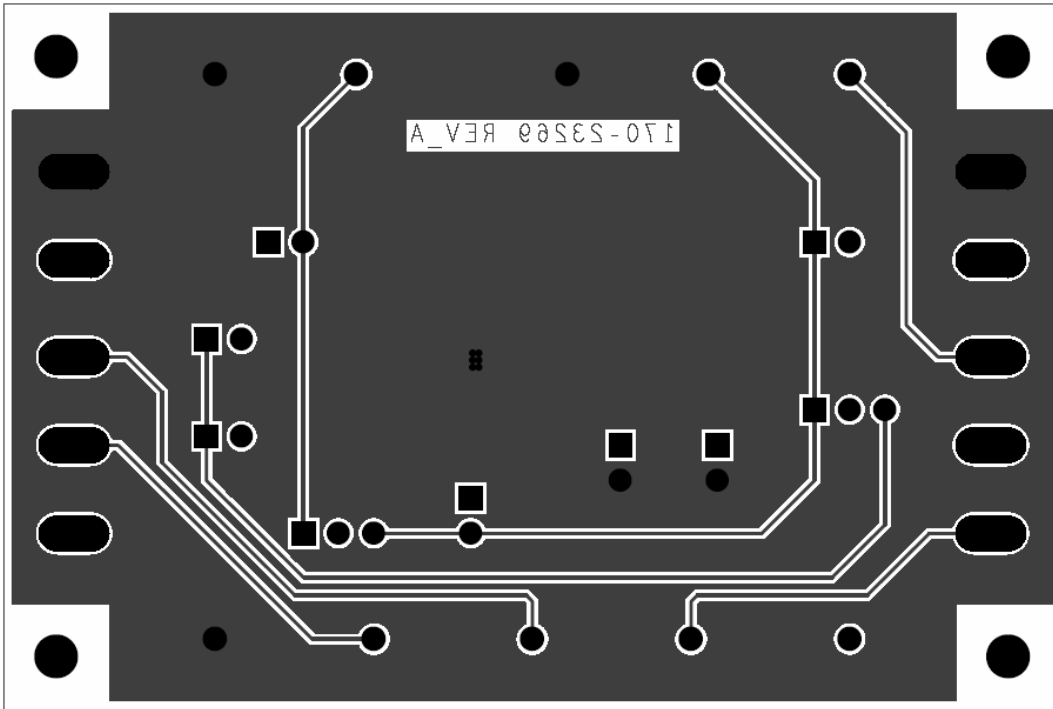

Figure 7. The Solder Side Layer of the Evaluation Board

6.2 Layout considerations

- Place decoupling capacitors C1 and C2 as close as possible to the VIN pin and BAT pin respectively.
- Place the charge current setting resistor as close as possible to the ISET pin to minimize the parasitic capacitance between the ISET pin and ground.
- Use wide traces to connect input power to the VIN pin and BAT pin to the battery.
- To get better thermal performance, put the EPAD pin of the MC34671 on a large ground plane on the component side, and use a via array to connect the EPAD pin to the ground layer, or the large ground plane on the other layer.

7 Evaluation Board Configuration

7.1 Pin Headers

The JP1 pin header links the external DC power supply to the VIN pin of the MC34671. This allows the user to measure the current from the DC power supply to the evaluation board when using a current meter between pin 1 and pin 2 of JP1. The default setting of JP1 is to short pins 1 and 2.

The JP2 pin header selects the voltage to supply the D1 and D2 LED indicators. Shorting pins 1 and 2 selects VIN to power the LEDs. Shorting pins 2 and 3 selects the BAT pin to power the LEDs.

IMPORTANT: DO NOT APPLY HIGHER THAN 12V DC INPUT VOLTAGE TO VIN IF PINS 1 and 2 ARE SHORTED.

The absolute maximum voltage at the $\overline{\text{PPR}}$ and $\overline{\text{CHG}}$ pin is 12V. When applying higher than a 12V input voltage, select BAT to power the LEDs.

The JP3 pin header allows the user to disable the MC34671 when shorting pins 1 and 2. Leaving it open enables the MC34671.

The JP4 pin header links the BAT pin and the external battery connector. It allows the user to measure the charging current from the MC34671 into the battery with a current meter between pins 1 and 2. The default setting is to short pins 1 and 2.

JP5 and JP6 are used to let the user supply an I/O logic voltage to $\overline{\text{PPR}}$ and $\overline{\text{CHG}}$, so the system can interface to the PPR and CHG signals with the same voltage level. When using LEDs to indicate the charging status, leave JP5 and JP6 open. When interfacing the PPR and CHG signal to the system, short pins 1 and 2 of JP5 and JP6, and leave JP2 open.

JP7 and JP8 set the charge current. The current values related to JP7 and JP8 settings are shown in [Table 2](#).

JP9 selects the power supply for pulling up the voltage of the $\overline{\text{FAST}}$ signal. Shorting pins 1 and 2 selects the externally supplied I/O logic voltage. Shorting pins 2 and 3 selects the battery voltage.

The default configuration of the evaluation board is a standalone charger. The default settings of the evaluation board are shown in [Table 3](#).

Table 3. The Default Settings of the Pin Headers for Standalone Chargers

Pin Header Jumpers	Default Setting
JP1	Shorted
JP2	1 and 2 shorted
JP3	Open
JP4	Shorted
JP5	Open
JP6	Open
JP7	Shorted
JP8	Shorted
JP9	1 and 2 shorted

When using the evaluation board to connect to the system, please apply the required I/O logic voltage at the VL pad of the evaluation board and set the pin header jumpers as shown in [Table 4](#).

Table 4. The Settings of the Pin Headers for an Embedded Charger Connecting to the System

Pin Header Jumpers	Default Setting
JP1	Shorted
JP2	Open
JP3	Open
JP4	Shorted
JP5	Shorted
JP6	Shorted
JP7	Shorted
JP8	Shorted
JP9	2 and 3 shorted

7.2 Connector Pads

There are 10 connecting pads (J1 to J10 with corresponding names) on the evaluation board to let the user simply connect the board to their system. The GND pads link power ground of the MC34671. The INPUT pad connects an external DC power supply to the evaluation board. The PPR, CHG, EN, FAST, and ISET pads link to the corresponding pins of the MC34671. The VL pad is used for the user to supply a logic I/O voltage to the evaluation board, in case the application system needs a logic voltage level to interface to the PPR, CHG, and FAST pins of the MC34671. The VBAT pad connects the positive pole of the Li+ battery being charged.

7.3 Test points

The KIT34671 evaluation board provides 7 signal test points and 3 ground test points for users to conveniently hookup multi-meters and oscilloscope probes to evaluate the MC34671. The test points connect the pins of the MC34671 with the same name directly.

8 Test Setup with the Evaluation Board

The test setup is shown in **Figure 8**. Connect a DC power source with a larger than 1.0A current limit to the INPUT pad on the evaluation board. Connect the positive and negative polarities of the Li+ battery to the VBAT pad and the GND pad on the evaluation board respectively. Use a current meter and a voltage meter to measure the charge current and the voltage respectively. Turn on the power supply and the evaluation board starts charging the battery.

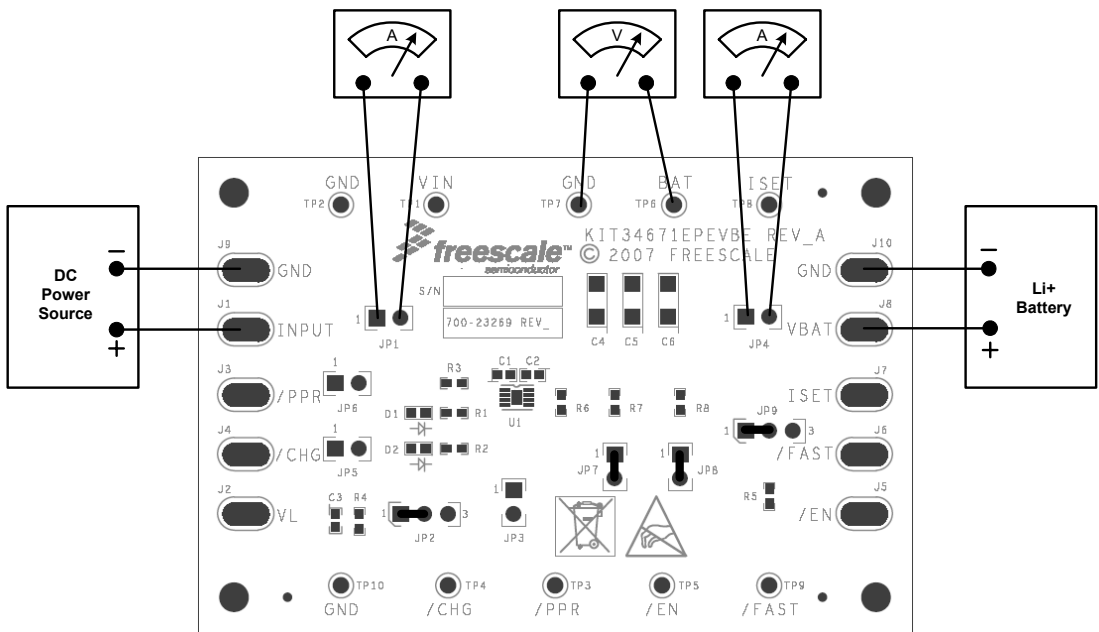

Figure 8. The Test Set Up for the Evaluation Board

9 References

- [MC34671PG Quick Reference](#)
- [MC34671 Data Sheet](#)