

IM72D128V01

IP57 dust and water resistant digital PDM XENSIV™ MEMS microphone

Description

The IM72D128V01 is an ultra-high performance digital PDM MEMS microphone designed for applications which require a very high SNR (low self-noise) and low distortion (high AOP) and which is also IP57 robust to dust and water.

Best-in-class signal-to-noise ratio (SNR) of 72dB(A) enables far field and low volume audio pick-up. The flat frequency response (20Hz low-frequency roll-off) and tight manufacturing tolerance improve performance of multi-microphone (array) applications.

The digital microphone ASIC contains an extremely low-noise preamplifier and a high-performance sigma-delta ADC. Different power modes can be selected in order to suit specific clock frequency and current consumption requirements.

Each IM72D128V01 microphone is calibrated with an advanced Infineon calibration algorithm, resulting in low sensitivity tolerances (± 1 dB).

Features

- Component level IP57 water and dust resistant
- Dynamic range of 106dB
- Acoustic overload point at 128dB SPL
- Signal to noise ratio of 72dB(A) SNR
- Digital PDM output
- Flat frequency response with a low frequency roll-off at 20Hz
- Package dimensions: 4mm x 3mm x 1.2mm
- Omnidirectional pickup pattern
- Power optimized modes determined by PDM clock frequency

Typical applications

- Active Noise Cancellation (ANC) headphones and earphones
- Devices with Voice User Interface (VUI)
 - Smart speakers
 - Home automation
 - IOT devices
- High quality audio capturing
 - Laptops and tablets
 - Conference systems
 - Cameras and camcorders
- Industrial or home monitoring with audio pattern detection

Ordering information

Table 1 **Ordering information**

Product name	Package	Marking	Ordering code
IM72D128V01	PG-LLGA-5-3	I72D07	SP005738480

Product validation

Product validation

Technology qualified for industrial applications.

Ready for validation in industrial applications according to the relevant tests of IEC 60747 and 60749 or alternatively JEDEC47/20/22.

Block diagram

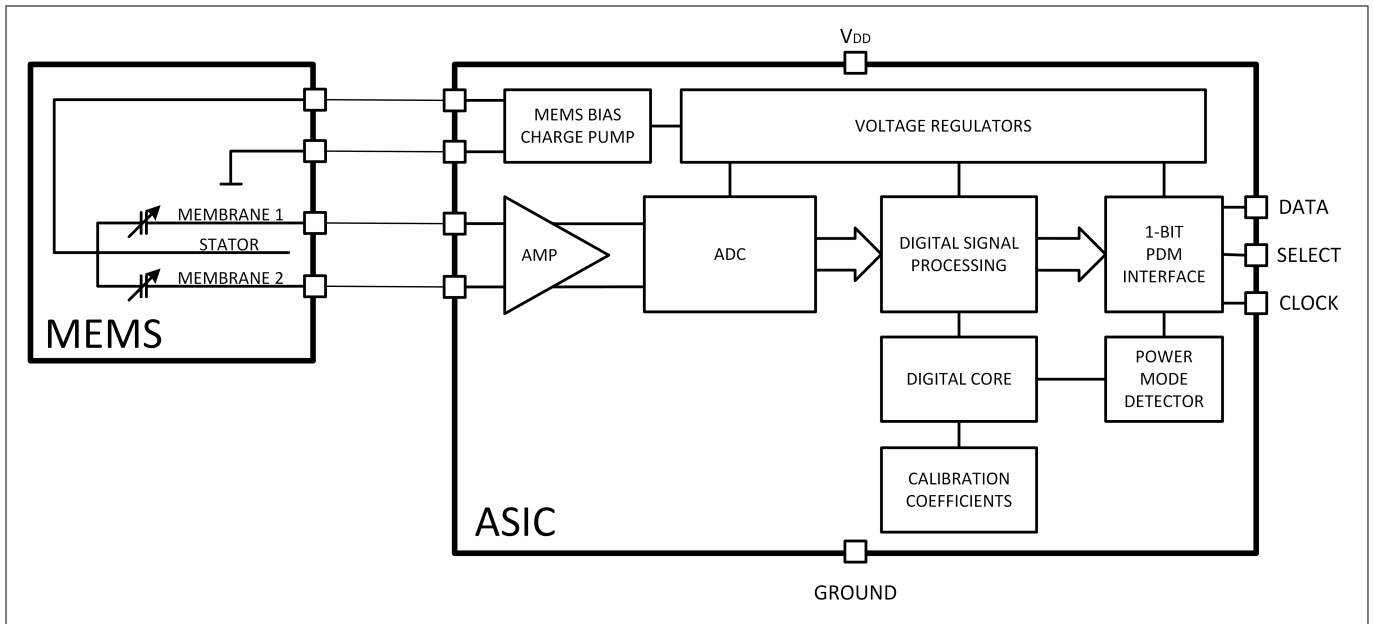

Figure 1 Block diagram

Environmental robustness

Infineon’s latest Sealed Dual Membrane MEMS technology delivers high ingress protection (IP57) at a microphone level. The sealed MEMS design prevents water or dust from entering between membrane and backplate, preventing mechanical blockage or electric leakage issues commonly observed in MEMS microphones. Microphones built with the Sealed Dual Membrane technology can be used to create IP68 devices, requiring only minimal mesh protection.

Table 2 Environmental robustness

Test Standard	Test Condition
IP5x dust resistance ¹⁾	Arizona dust A4 coarse, vertical orientation , sound hole upwards, 10 cycles (15 minutes sedimentation, 6 sec blowing)
IPx7 water immersion ²⁾	Temporary immersion of 1 meters for 30 minutes. Microphone tested 2 hours after removal

¹⁾ The number "5" stands for the dust ingress rating or the capacity to withstand the effects of fine, abrasive dust particles.

²⁾ The "7" specifies the higher water immersion rating.

Table of contents

	Description	1
	Features	1
	Typical applications	1
	Ordering information	1
	Product validation	2
	Block diagram	2
	Environmental robustness	2
	Table of contents	3
1	Typical performance characteristics	4
2	Acoustic characteristics	6
3	Electrical characteristics and parameters	7
3.1	Absolute maximum ratings	7
3.2	Electrical parameters	7
3.3	Electrical characteristics	8
3.4	Audio DC offset	9
3.5	Stereo PDM configuration	10
4	Package information	11
5	Footprint and stencil recommendation	12
6	Packing information	13
7	Reflow soldering and board assembly	14
8	Reliability specifications	16
	Revision history	17
	Disclaimer	18

Typical performance characteristics

1 Typical performance characteristics

Test conditions: $V_{DD} = 1.8V$, $f_{CLK} = 3.072MHz$, unless otherwise specified.

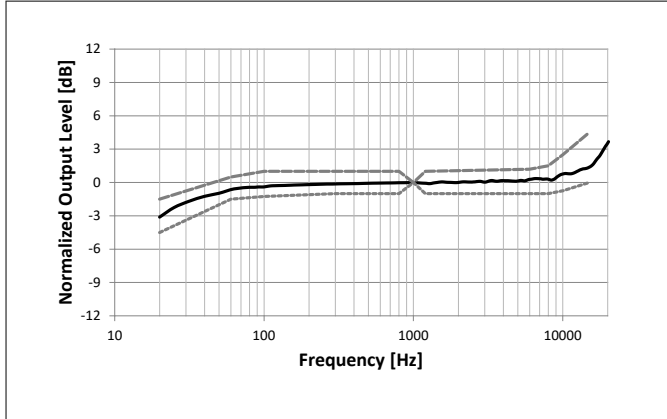

Figure 2 Typical amplitude response

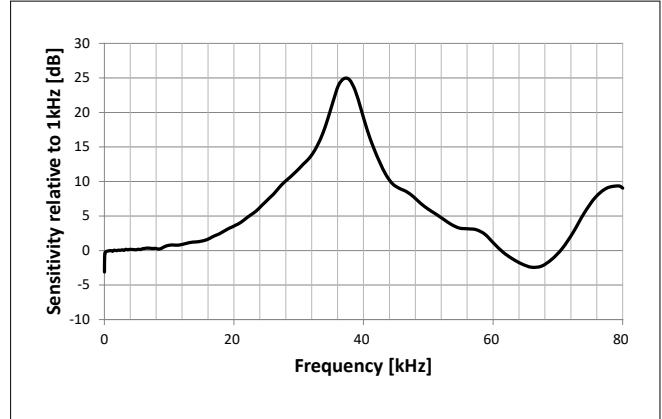

Figure 3 Typical free field ultrasonic response

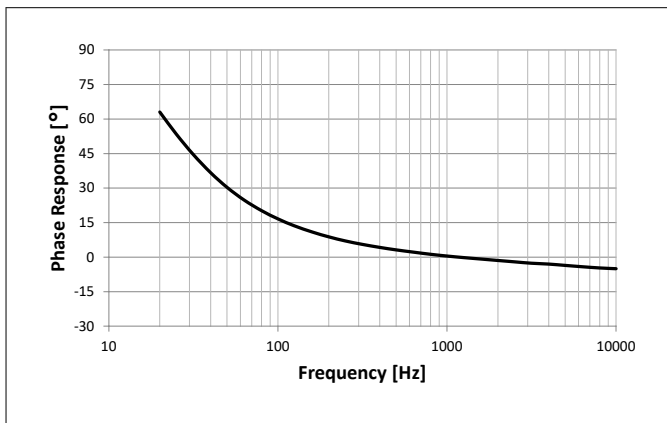

Figure 4 Typical phase response

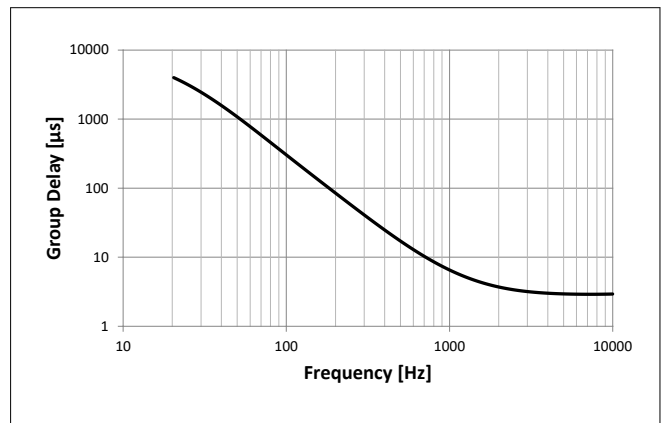

Figure 5 Typical group delay

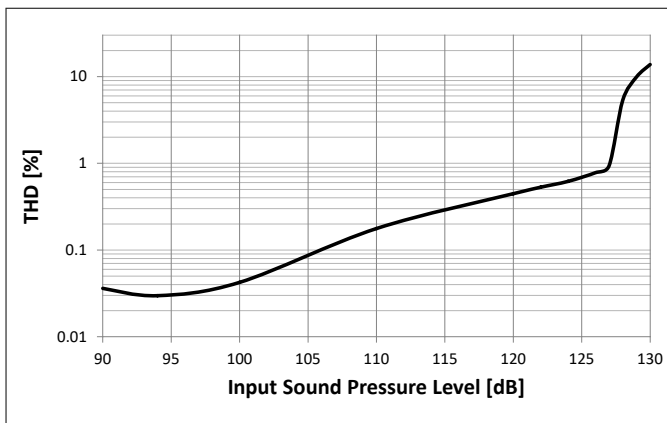

Figure 6 Typical THD vs SPL

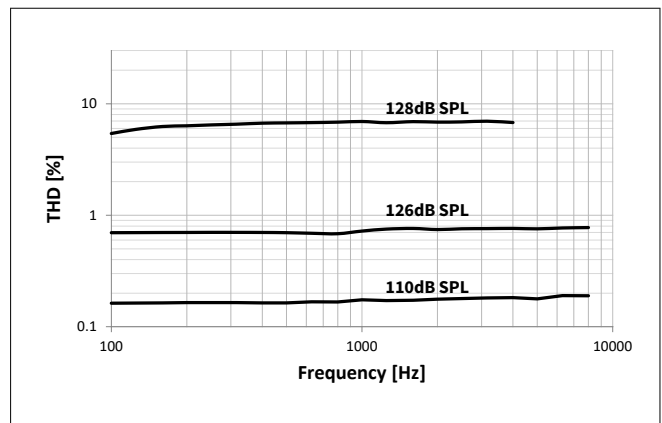

Figure 7 Typical THD vs frequency

Typical performance characteristics

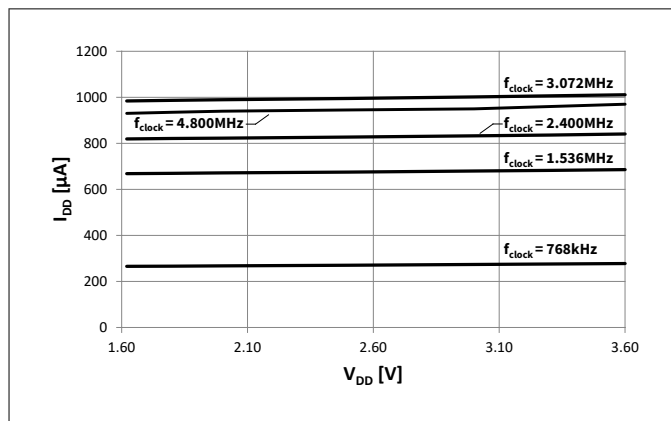

Figure 8 Typical I_{DD} vs V_{DD}

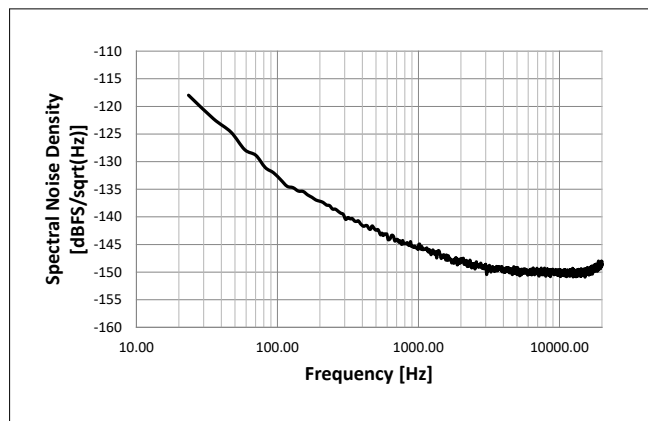

Figure 9 Typical noise floor (unweighted)

Acoustic characteristics

2 Acoustic characteristics

Test conditions (unless otherwise specified in the table): $V_{DD} = 1.8V$, $f_{CLK} = 3.072MHz$, $T_A = 25^\circ C$, 55% R.H., audio bandwidth 20Hz to 20kHz, select pin grounded, no load on DATA, $T_{edge} = 9ns$

Table 3 acoustic specifications

Parameter	Symbol	Values			Unit	Note or Test Condition	
		Min.	Typ.	Max.			
Sensitivity	S	-37	-36	-35	dBFS	1kHz, 94dB SPL, all operating modes	
Low Frequency Roll-off	LFRO		20		Hz	-3dB relative to 1kHz	
High Frequency Flatness ³⁾			19		kHz	+3dB relative to 1kHz	
Resonance Frequency Peak ³⁾			37		kHz		
Signal to Noise Ratio	$f_{clock} = 768kHz$	SNR		67		dB(A)	20Hz to 8kHz bandwidth, A-Weighted
	$f_{clock} = 1.536MHz$			68			
	$f_{clock} = 2.4MHz$			71.5			20Hz to 20kHz bandwidth, A-Weighted
	$f_{clock} = 3.072MHz$			72			
	$f_{clock} = 4.8MHz$ ³⁾			71.5			
Total Harmonic Distortion	94dB SPL	THD		0.5		%	Measuring 2nd to 5th harmonics; 1kHz. all operating modes
	126dB SPL			1.0			
Acoustic Overload Point	10% THD	AOP		128		dB SPL	Measuring 2nd to 5th harmonics; 1kHz. all operating modes
Group Delay	250Hz			60		μs	
	600Hz			12			
	1kHz			7			
	4kHz			3.5			
Phase Response	75Hz			20		°	
	1kHz			0.5			
	4kHz			-2			
Directivity			Omnidirectional				
Polarity		Positive pressure increases density of 1's, negative pressure decreases density of 1's in data output					

³⁾ Parameter not subject to productive test. Verified by laboratory characterization / design.

Electrical characteristics and parameters

3 Electrical characteristics and parameters

3.1 Absolute maximum ratings

Stresses at or above the listed maximum ratings may affect device reliability or cause permanent device damage. Functional device operation at these conditions is not guaranteed.

Table 4 Absolute maximum ratings

Parameter	Symbol	Values		Unit	Note / Test Condition
		Min.	Max.		
Voltage on any Pin	V_{max}		3.6	V	
Storage Temperature	T_S	-40	125	°C	
Ambient Temperature	T_A	-40	85	°C	

3.2 Electrical parameters

Table 5 Electrical parameters and digital interface input

Parameter	Symbol	Values			Unit	Note / Test Condition	
		Min.	Typ.	Max.			
Supply Voltage	V_{DD}	1.62	1.8	3.6	V	4)	
Clock Frequency Range	Standby Mode	f_{clock}			350	kHz	5)
	Low Power Mode		450	768	850	kHz	
	Normal Mode		1.2	1.536	1.65	MHz	
	High Performance Mode		2.0	2.4	2.6	MHz	
			2.9	3.072	3.3	MHz	
Ultrasonic Mode	4.56	4.8	5.04	MHz			
V_{DD} Ramp-up Time				50	ms	Time until $V_{DD} \geq V_{DD_min}$	
Input Logic Low Level	V_{IL}	-0.3		$0.35 \times V_{DD}$	V		
Input Logic High Level	V_{IH}	$0.65 \times V_{DD}$		$V_{DD} + 0.3$	V		
Clock Rise/Fall Time				13	ns	10% to 90%	
Clock Duty Cycle		40		60	%	$f_{clock} \leq 3\text{MHz}$	
		48		52	%	$f_{clock} > 3\text{MHz}$	
Output Load Capacitance on DATA	C_{load}			200	pF		

⁴ A 1 μ F bypass capacitor shall be placed close to the microphone V_{DD} pad to ensure best SNR performance.

⁵ Data pad is high impedance in standby mode.

Electrical characteristics and parameters

3.3 Electrical characteristics

Test conditions (unless otherwise specified in the table): $V_{DD} = 1.8V$, $T_A = 25^\circ C$, 55% R.H.

Table 6 General electrical characteristics

Parameter		Symbol	Values			Unit	Note / Test Condition
			Min.	Typ.	Max.		
Current Consumption	Clock Off Mode	$I_{\text{clock_off}}$			1	μA	CLOCK pulled low
	Standby Mode	I_{standby}		25	50		No load on DATA
	$f_{\text{clock}} = 768\text{kHz}$	I_{DD}		280	310		<5pF load on DATA
	$f_{\text{clock}} = 1.536\text{MHz}$			690	770		
	$f_{\text{clock}} = 2.4\text{MHz}$			820	945		
	$f_{\text{clock}} = 3.072\text{MHz}$			980	1120		
	$f_{\text{clock}} = 4.8\text{MHz}$			900	1000		
Short Circuit Current			1		20	mA	Grounded DATA pin
Power Supply Rejection		PSR_{1k_NM}		-80		dBFS	100mV _{pp} sine wave on V_{DD} swept from 200Hz to 20kHz.
		PSR_{217_NM}		-86		dBFS(A)	100mV _{rms} , 217Hz square wave on V_{DD} . A-weighted.
Startup Time	$\pm 0.5\text{dB}$ sensitivity accuracy				20	ms	Time to start up in any operating modes after V_{DD_min} and CLOCK have been applied. ⁶⁾
	$\pm 0.2\text{dB}$ sensitivity accuracy				50		
Mode Switch Time	$\pm 0.5\text{dB}$ sensitivity accuracy				20	ms	Time to switch between operating modes. V_{DD} remains on during the mode switch. ⁶⁾
	$\pm 0.2\text{dB}$ sensitivity accuracy				50		
Output Logic Low Level		V_{OL}			$0.3 \times V_{DD}$	V	
Output Logic High Level		V_{OH}	$0.7 \times V_{DD}$				
Delay Time for DATA Driven		t_{DD}	40		80	ns	Delay time from CLOCK edge ($0.5 \times V_{DD}$) to DATA driven.
Delay Time for DATA High-Z ⁷⁾		t_{HZ}	5		30	ns	Delay time from CLOCK edge ($0.5 \times V_{DD}$) to DATA high impedance state

(table continues...)

⁶⁾ Verified at typical PDM clock frequencies for each power mode.

⁷⁾ t_{hold} is dependent on C_{load}

Electrical characteristics and parameters

Table 6 (continued) General electrical characteristics

Parameter	Symbol	Values			Unit	Note / Test Condition
		Min.	Typ.	Max.		
Delay Time for DATA Valid ⁸⁾	t_{DV}			100	ns	Delay time from CLOCK edge ($0.5 \times V_{DD}$) to DATA valid ($< 0.3 \times V_{DD}$ or $> 0.7 \times V_{DD}$)
Power-on behaviour	Idle tone is output over PDM within 3ms of applying V_{DD} and f_{clock} , remains until a valid microphone signal is available. Idle tone consists of alternating 1s and 0s, representing a zero input signal.					

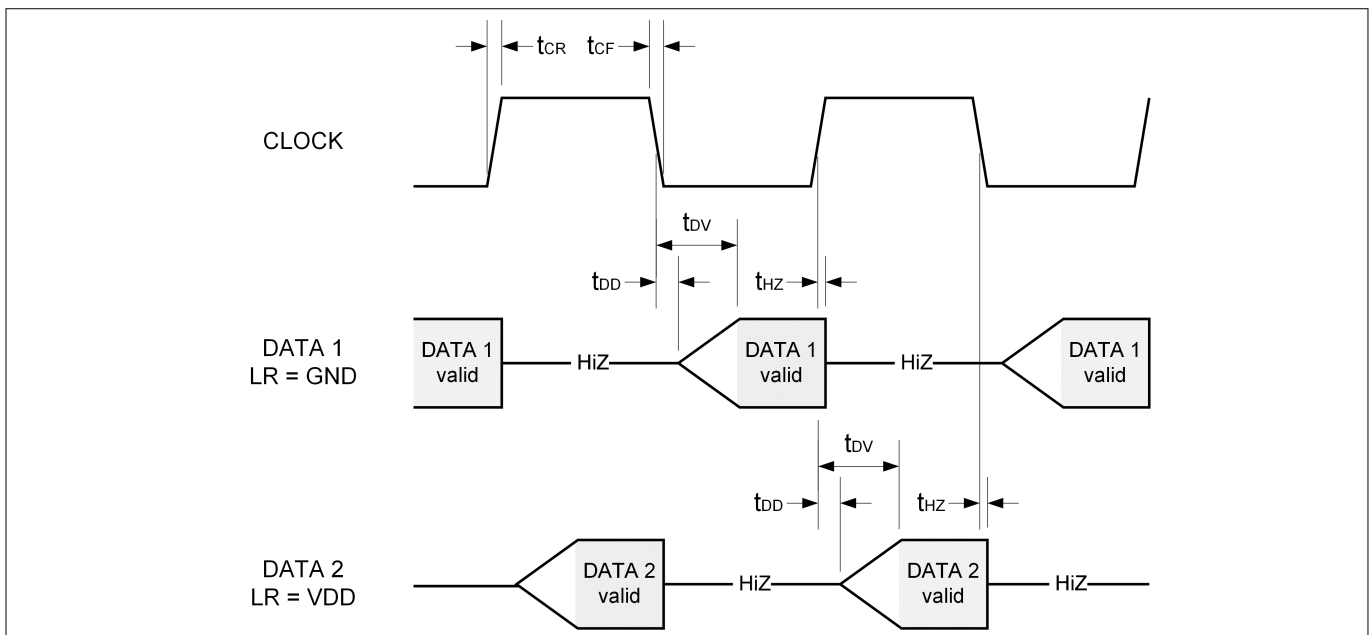

Figure 10 Timing diagram

3.4 Audio DC offset

The DC output level encoded in the DC bit stream is determined by the L/R state on startup. In each case the DC output level is stable over time and does not vary with input signal level.

Table 7 DC output level using L/R pin

LR state	DC output level (typical)	Unit
LR = GND	-80	dBFS
LR = VDD	-40	dBFS

⁸ Load on data: $C_{load}=100pF$, $R_{load}=100k\Omega$

3.5 Stereo PDM configuration

The IM72D128V01 is designed to function in circuits with one or two microphones on the PDM bus. When two microphones are connected, data is transmitted alternately according to the L/R pin status of each microphone. When two microphones are connected to a shared PDM bus, the power modes of both microphones will be the same as both are controlled by the same PDM clock. The performance is unchanged relative to a single microphone per bus configuration.

Table 8 PDM channel configuration using L/R pin.

Channel	Data driven	Data high-Z	L/R connection
DATA1	Falling clock edge	Rising clock edge	GND
DATA2	Rising clock edge	Falling clock edge	V _{DD}

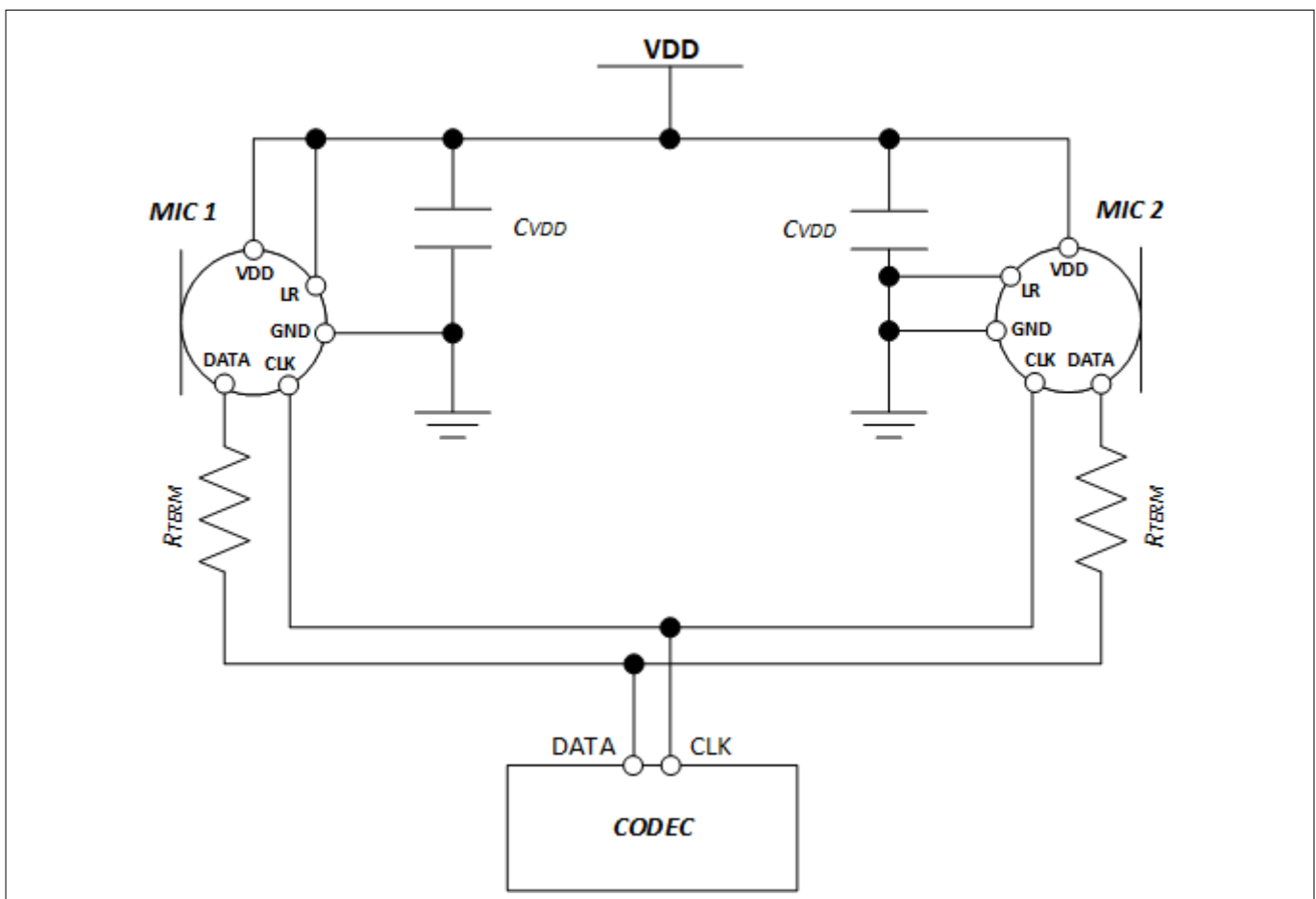

Figure 11 Typical stereo mode configuration

Note: For best performance it is strongly recommended to place a 100nF ($C_{VDD_typical}$) capacitor between V_{DD} and ground. The capacitor should be placed as close to V_{DD} as possible. A termination resistor (R_{TERM}) of about 100Ω may be added to reduce the ringing and overshoot on the output signal.

Package information

4 Package information

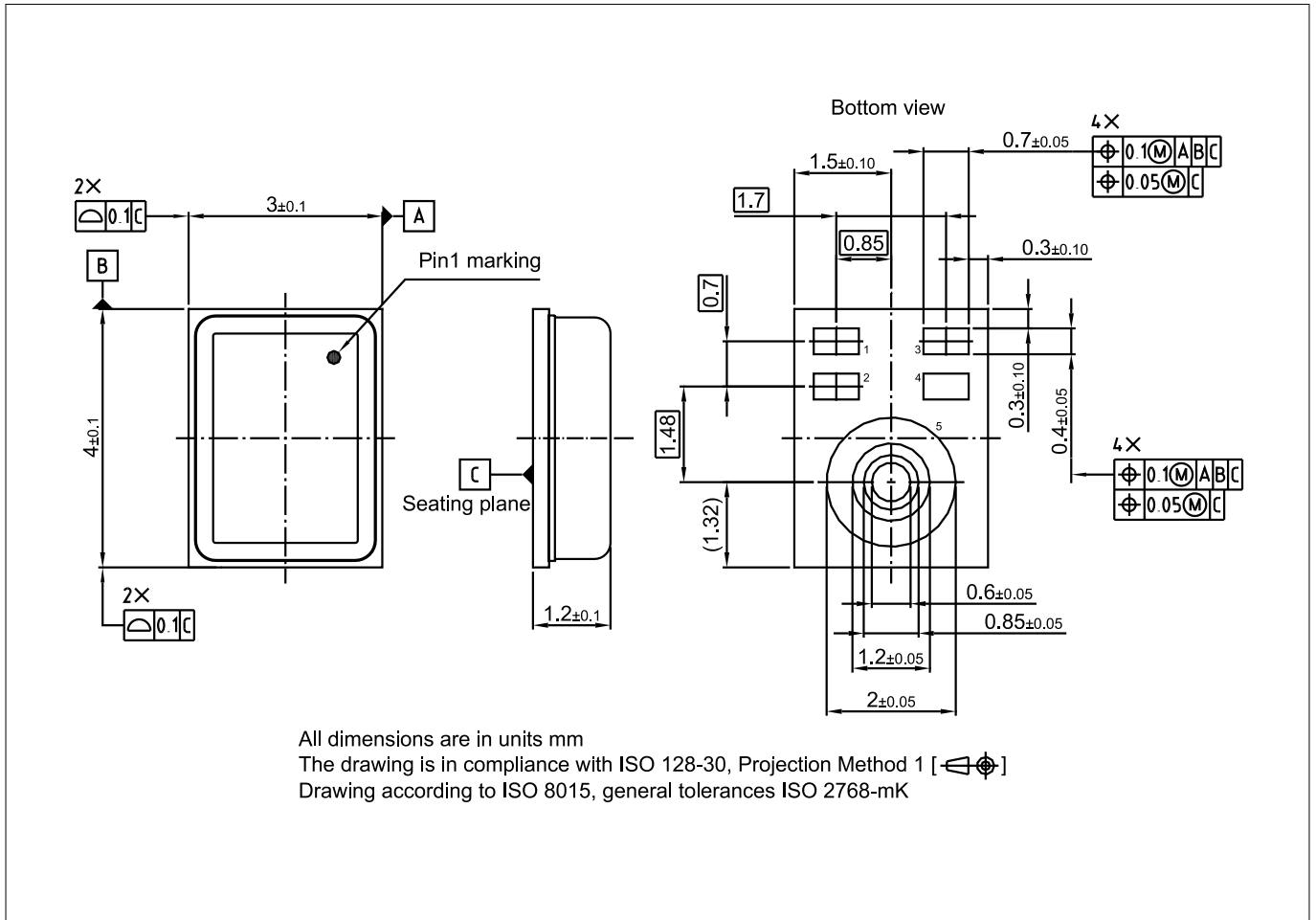

Figure 12 IM72D128V01 package drawing

Table 9 IM72D128V01 pin configuration

Pin Number	Name	Description
1	DATA	PDM data output
2	V _{DD}	Power supply
3	CLOCK	PDM clock input
4	SELECT	PDM left/right select
5	GND	Ground

Footprint and stencil recommendation

5 Footprint and stencil recommendation

The acoustic port hole diameter in the PCB should be larger than the acoustic port hole diameter of the MEMS Microphone to ensure optimal performance. A PCB sound port size of radius 0.4 mm (diameter 0.8mm) is recommended.

The board pad and stencil aperture recommendations shown in Figure 13 are based on Solder Mask Defined (SMD) pads. The specific design rules of the board manufacturer should be considered for individual design optimizations or adaptations.

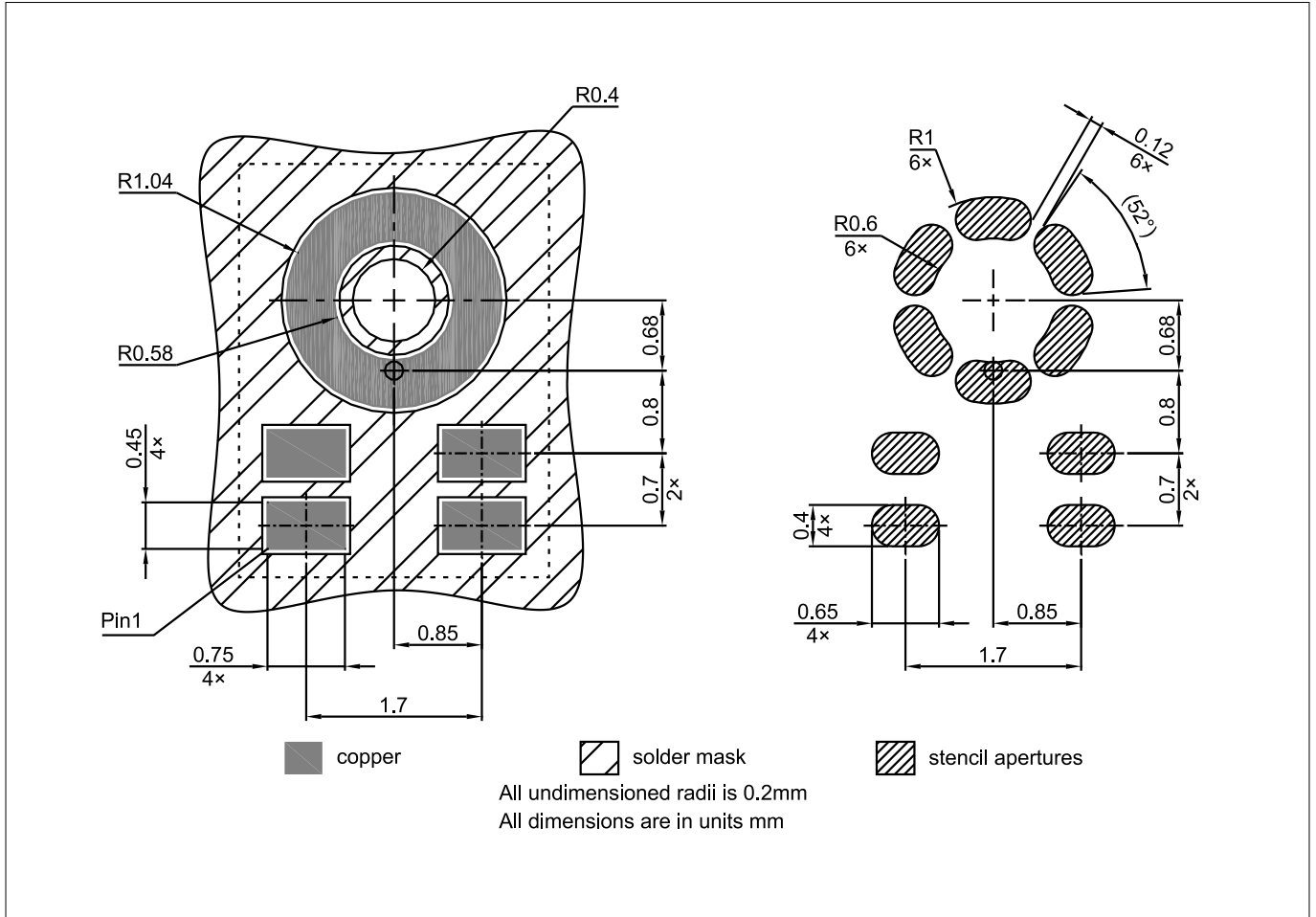

Figure 13 IM72D128V01 footprint and stencil recommendation

Note: Dimensions are in millimeters unless otherwise specified

Packing information

6 Packing information

For shipping and assembly the Infineon microphones are packed in product specific tape-and-reel carriers. A detailed drawing of the carrier can be seen in [Figure 14](#).

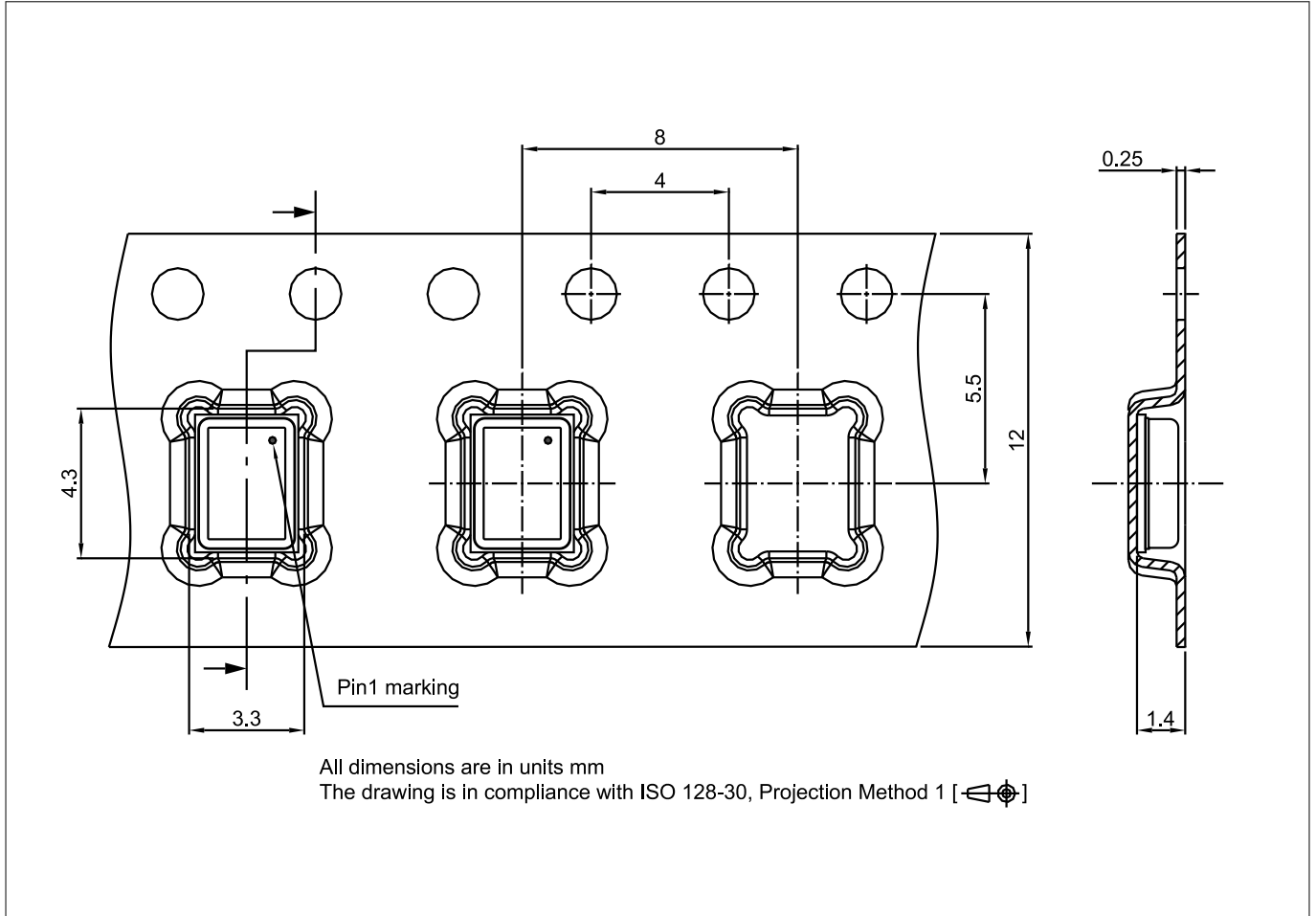

Figure 14 IM72D128V01 tape and reel packing information

7 Reflow soldering and board assembly

Infineon MEMS microphones are qualified in accordance with the IPC/JEDEC J-STD-020D-01. The moisture sensitivity level of MEMS microphones is rated as MSL1. For PCB assembly of the MEMS microphone the widely used reflow soldering using a forced convection oven is recommended.

The soldering profile should be in accordance with the recommendations of the solder paste manufacturer to reach an optimal solder joint quality. The reflow profile shown in Figure 15 is recommended for board manufacturing with Infineon MEMS microphones.

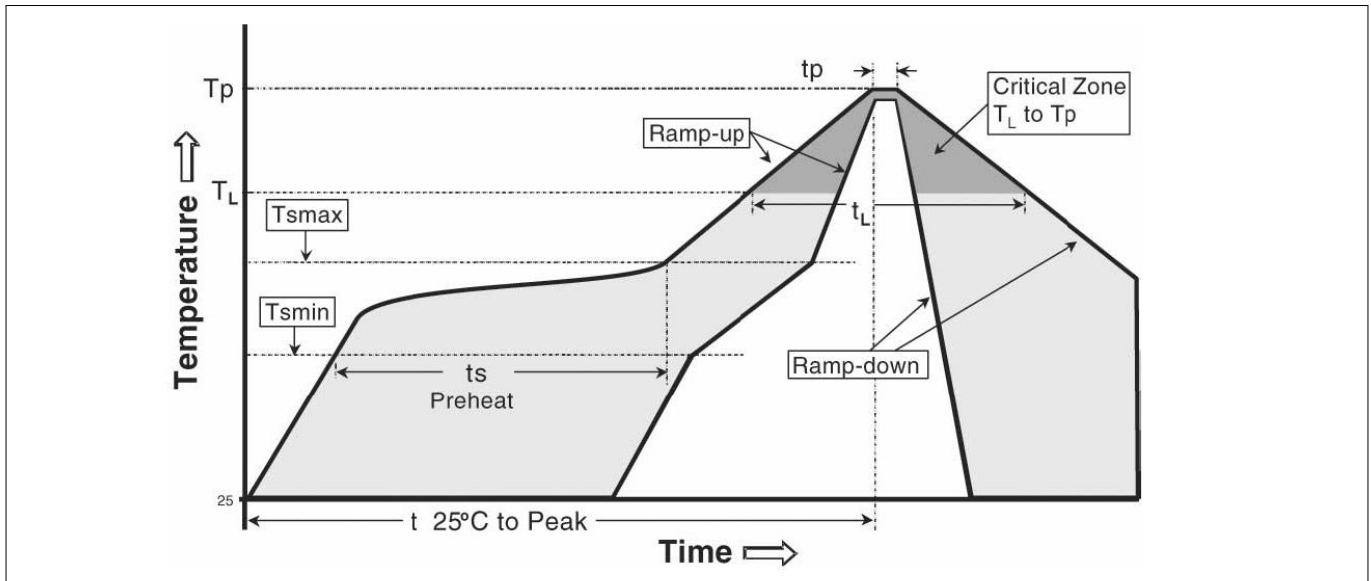

Figure 15 Recommended reflow profile

Table 10 Reflow profile limits

Profile feature	Pb-Free assembly	Sn-Pb Eutectic assembly
Temperature Min (T_{smin})	150 °C	100 °C
Temperature Max (T_{smax})	200 °C	150 °C
Time (T_{smin} to T_{smax}) (t_s)	60-120 seconds	60-120 seconds
Ramp-up rate (T_L to T_p)	3 °C/second max.	3 °C/second max.
Liquidous temperature (T_L)	217 °C	183 °C
Time (t_L) maintained above T_L	60-150 seconds	60-150 seconds
Peak Temperature (T_p)	260°C +0°C/-5°C	235°C +0°C/-5°C
Time within 5°C of actual peak temperature (t_p) ⁹⁾	20-40 seconds	10-30 seconds
Ramp-down rate	6 °C/second max.	6 °C/second max.
Time 25°C to peak temperature	8 minutes max.	6 minutes max.

Note: For further information please consult the 'General recommendation for assembly of Infineon packages' document which is available on the Infineon Technologies [web page](#)

⁹⁾ Tolerance for peak profile temperature (T_p) is defined as a supplier minimum and a user maximum

Reflow soldering and board assembly

The MEMS microphones can be handled using industry standard pick and place equipment. Care should be taken to avoid damage to the microphone structure as follows:

- Do not pick the microphone with vacuum tools which make contact with the microphone acoustic port hole.
- The microphone acoustic port hole should not be exposed to vacuum, this can destroy or damage the MEMS.
- Do not blow air into the microphone acoustic port hole. If an air blow cleaning process is used, the port hole must be sealed to prevent particle contamination.
- It is recommended to perform the PCB assembly in a clean room environment in order to avoid microphone contamination.
- Air blow and ultrasonic cleaning procedures shall not be applied to MEMS Microphones. A no-clean paste is recommended for the assembly to avoid subsequent cleaning steps. The microphone MEMS can be severely damaged by cleaning substances.
- To prevent the blocking or partial blocking of the sound port during PCB assembly, it is recommended to cover the sound port with protective tape during PCB sawing or system assembly.
- Do not use excessive force to place the microphone on the PCB. The use of industry standard pick and place tools is recommended in order to limit the mechanical force exerted on the package.

Reliability specifications

8 Reliability specifications

The microphone sensitivity after stress must deviate by no more than 3dB from the initial value.

Table 11 Reliability specification

Test	Abbreviation	Test Condition	Standard
Low Temperature Operating Life	LTOL	$T_a = -40^\circ\text{C}$, VDD=3.6V, 1000 hours	JESD22-A108
Low Temperature Storage Life	LTSL	$T_a = -40^\circ\text{C}$, 1000 hours	JESD22-A119
High Temperature Operation Life	HTOL	$T_a = +125^\circ\text{C}$, VDD=3.6V, 1000 hours	JESD22-A108
High Temperature Storage Life	HTSL	$T_a = +125^\circ\text{C}$, 1000 hours	JESD22-A103
Temperature Cycling	PC + TC	Pre conditioning MSL-1	JESD22-A113
		1000 cycles, -40°C to $+125^\circ\text{C}$, 30 minutes per cycle	JESD22-A104
Temperature Humidity Bias	PC + THB	Pre conditioning MSL-1	JESD22-A113
		$T_a = +85^\circ\text{C}$, R.H = 85%, VDD=3.6V, 1000 hours	JESD22-A101
Vibration Test	VVF	20Hz to 2000Hz with a peak acceleration of 20g in X, Y, and Z for 4 minutes each, total 4 -cycles	IEC 60068-2-6
Mechanical Shock	MS	10000g/0.1msec direction $\pm x, y, z$, 5 shocks in each direction, 5 shocks in total	IEC 60068-2-27
Reflow Solder ¹⁰⁾	RS	3 reflow cycles, peak temperature = $+260^\circ\text{C}$	IPC-JEDEC J-STD-020D-01
Electrostatic Discharge -System Level Test	ESD - SLT	3 discharges of $\pm 8\text{kV}$ direct contact to lid while V_{dd} is supplied according to the operational modes; (V_{dd} ground is separated from earth ground)	IEC-61000-4-2
Electrostatic Discharge - Human Body Model	ESD - HBM	1 pulse of $\pm 2\text{kV}$ between all I/O pin combinations	JEDEC-JS001
Electrostatic Discharge - Charged Device Model	ESD - CDM	3 discharges of $\pm 500\text{V}$ direct contact to I/O pins.	JEDEC JS-002
Latch up	LU	Trigger current from $\pm 200\text{mA}$	JESD78

¹⁰⁾ The microphone sensitivity must deviate by no more than 1dB from the initial value after 3 reflow cycles.

Revision history

Revision history

Document version	Date of release	Description of changes
1.00	2022-02-22	Initial release
1.01	2022-05-05	Corrected ordering information