

Motor Control Application Kit

KITMOTORDC250W24VTOB01

3-phase Motor Control Power Card

24V, 250W motor drive power card for XMC1000 and XMC4000

User Manual

About this document

Scope and purpose

This document describes in technical details the implementation and use of a 3-phase motor drive power card. The card has been designed to operate in various configurations and conditions, such input voltages and control algorithms.

The hardware is compatible with XMC DriveCards and DAVE™ configurations.

Attention: *This board is intended for evaluation purposes only and is not intended to be an end product.*

The design of this board originates from the need of a simple and plug-and-play motor drive power card to be used for XMC evaluation purposes in motor drive applications.

The layout of the board has been studied to offer a good starting reference to designers.

Intended audience

Design engineers approaching a low-voltage motor drive system either in H-Bridge or in 3-Phase full bridge configuration.

1 Table of Contents

2	1	Introduction	2
3	2	Block diagram	3
4	3	Hardware description.....	4

1 Introduction

This document describes the features and hardware details of the “3-phase motor control Power Card” which is designed to work with Infineon’s DriveCards. DriveCards are microcontroller boards with isolated debug interface best suited for motor control applications. This power board works with DriveCards KIT_XMC1300_DC_V1 and KIT_XMC4400_DC_V1.

The “3-phase motor control Power Card” is designed to work under several supply voltage levels which are described in TABLEXX. A first buck converter produces the regulated 12V supply for the MOSFETs gate driving and a second buck converter generates the regulated 5V supply for the microcontroller and the analog signal conditioning.

The 3-phase bridge is composed by three Half-Bridges with SO8 gate driver IC and SSO8 power MOSFETs. Each leg provides a shunt resistor with amplifier for reconstruction of the phase current. A DC-link shunt is also provided. With the provided shunts configuration, the board provides flexibility to adopt many different control algorithms.

2 Block diagram

Figure 1 Shows a simplified block diagram of the hardware, which includes:

- 3-phase motor drive bridge, equipped with 6x BSC014No6N from OptiMOS™ 80V family, 1.4mOhm (max) power MOSFETs in SSO8 package
- Half-Bridge gate driver IC 2EDL05No6PF from EICEDriver™ COMPACT family in SO8 package with SOI technology
- SwitchedMode DC/DC buck converter IFX90121EL V50 for 5V supply
- SwitchedMode DC/DC buck converter for 12V supply
- Shunts to sense leg currents and DC-link current, with OpAmps for conditioning to XMC
- Resistor dividers to sense leg voltages and DC-link voltage, to XMC
- Additional general purpose Green-LED (EN, Enable port), 5V Green-LED and 12V Green-LED
- Additional general purpose trimmer to XMC

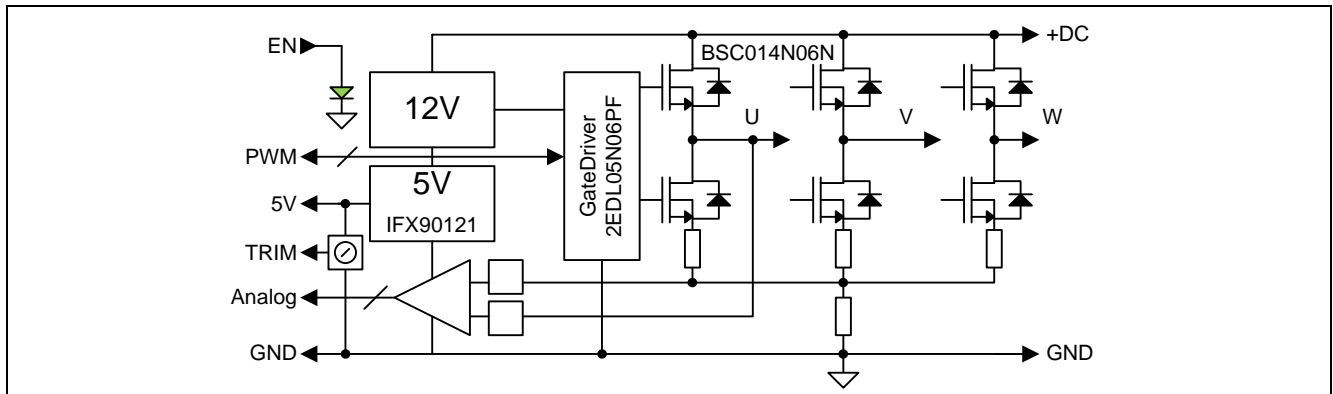

Figure 1 Simplified block diagram

3 Hardware description

The following sections give a detailed description of the hardware and how it can be used.

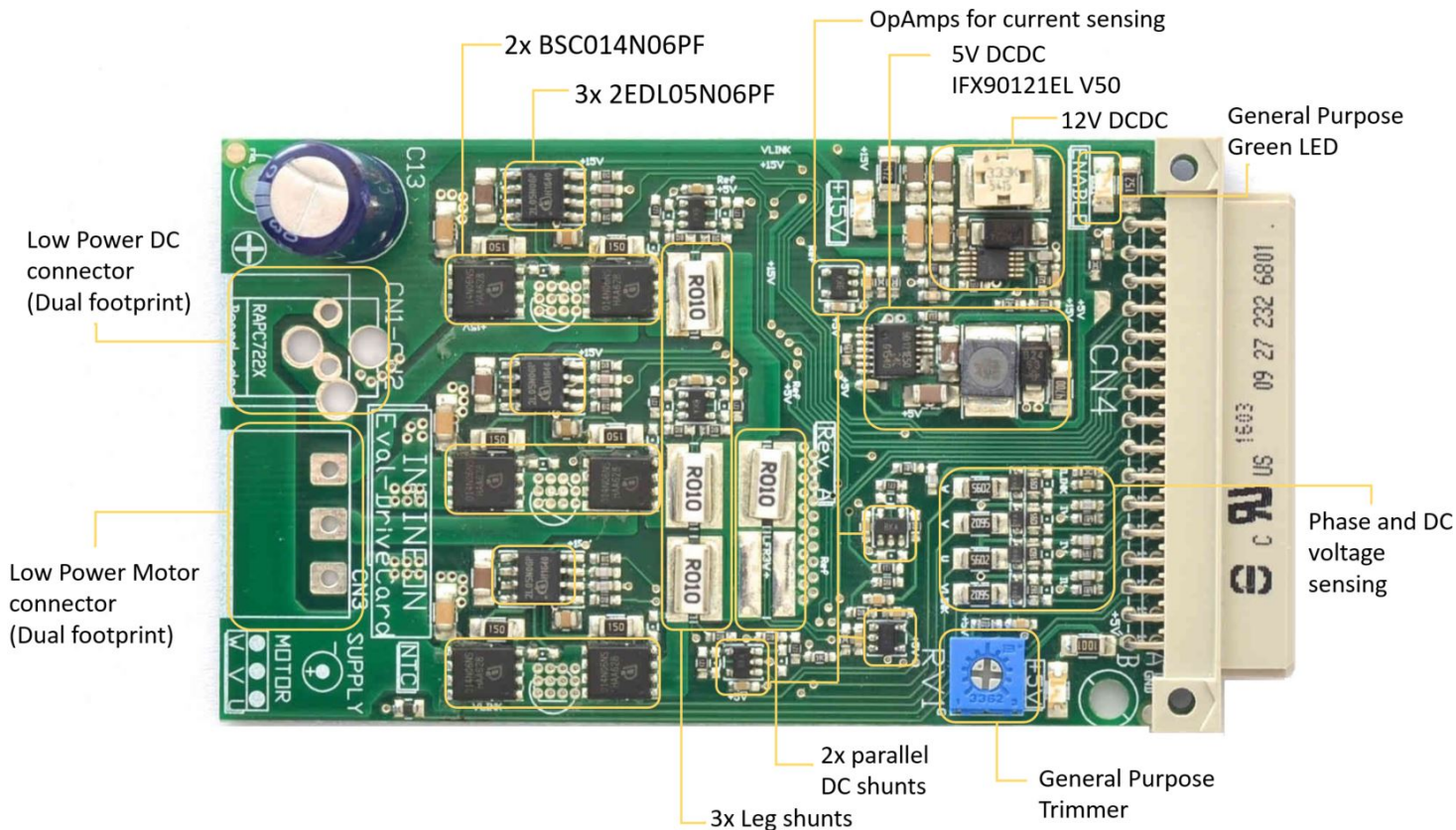

Figure 2 Hardware TOP overview

Table 1 Ratings

Description	Max	Typ	Notes
DC link input voltage	60V absolute max	24V	Hardware can run from 16V up to 42V operating
Output Power	TBD		No heatsink, still air, Ambient temperature, Test conditions TBD
Power mosfet ratings	60V BVDss abs max		BSC014No6N 1.4mOhm Rdson Max
SMPS IC rating	60V BVDss abs max		

3.1.1 Signal connector

The signal connector pin-out is listed below in Table 2. See also Figure 3 for reference.

1 Table 2 Signal connector pin-out

Row A (inner row)	Name	Notes	Row B (outer row)	Name	Notes
CN4-A16	GND	Ground	CN4-B16	VDD_5V	XMC supply
CN4-A15			CN4-B15		
CN4-A14	RVAR	Variable res	CN4-B14	TEMP	Temperature sense
CN4-A13			CN4-B13	DC_LINK_DIV_X	Voltage sense DC link
CN4-A12	I_U	Current sense U	CN4-B12	BEMF_U	Voltage sense phase U
CN4-A11	I_V	Current sense V	CN4-B11	BEMF_V	Voltage sense phase V
CN4-A10	I_W	Current sense W	CN4-B10	BEMF_W	Voltage sense phase W
CN4-A9	I_DC_LINK_AVG	Current sense DC link	CN4-B9	I_DC_LINK_0	
CN4-A8		NC	CN4-B8	U_L	Phase U low side command
CN4-A7		NC	CN4-B7	U_H	Phase U high side command
CN4-A6		NC	CN4-B6	V_L	Phase V low side command
CN4-A5		NC	CN4-B5	V_H	Phase V high side command
CN4-A4		NC	CN4-B4	W_L	Phase W low side command
CN4-A3		NC	CN4-B3	W_H	Phase W high side command
CN4-A2		NC	CN4-B2	/FO_0	Fault / NC
CN4-A1		NC	CN4-B1	/ENABLE_0	Driver enable

1

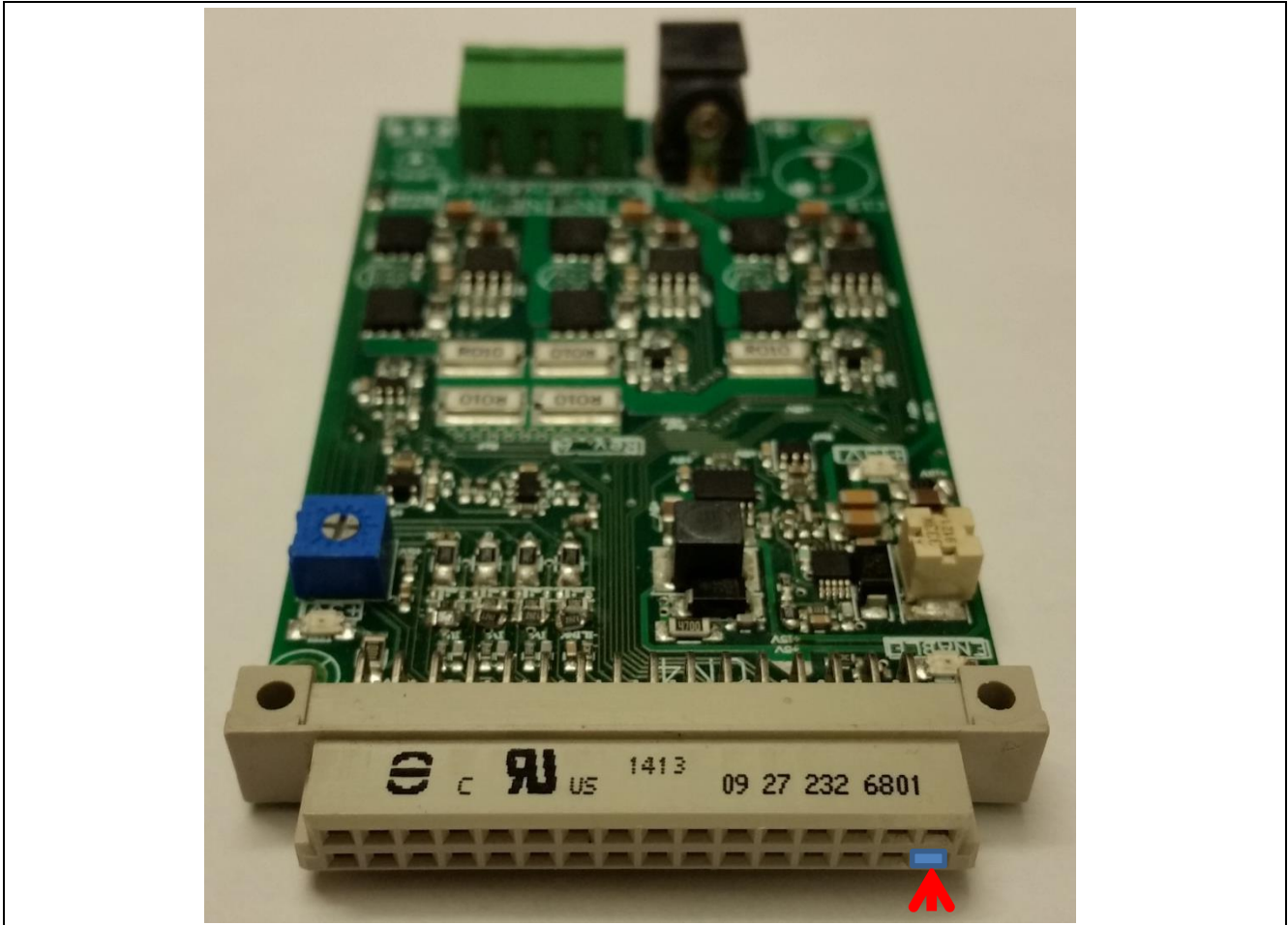

2 Figure 3 Signal DriveCard connector front view with pin-1/row A marked

3 **3.1.2 Input Power and motor connectors**

4 The board can be equipped with a standard low power RAPC 5A connector for demonstration purposes.

5 Pinout is providing also standard 2-pin 5mm spacing drills for higher power Voltage connection.

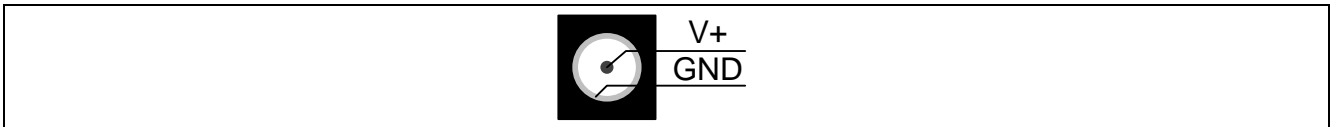

6 Figure 4 Jack Connector polarity

1

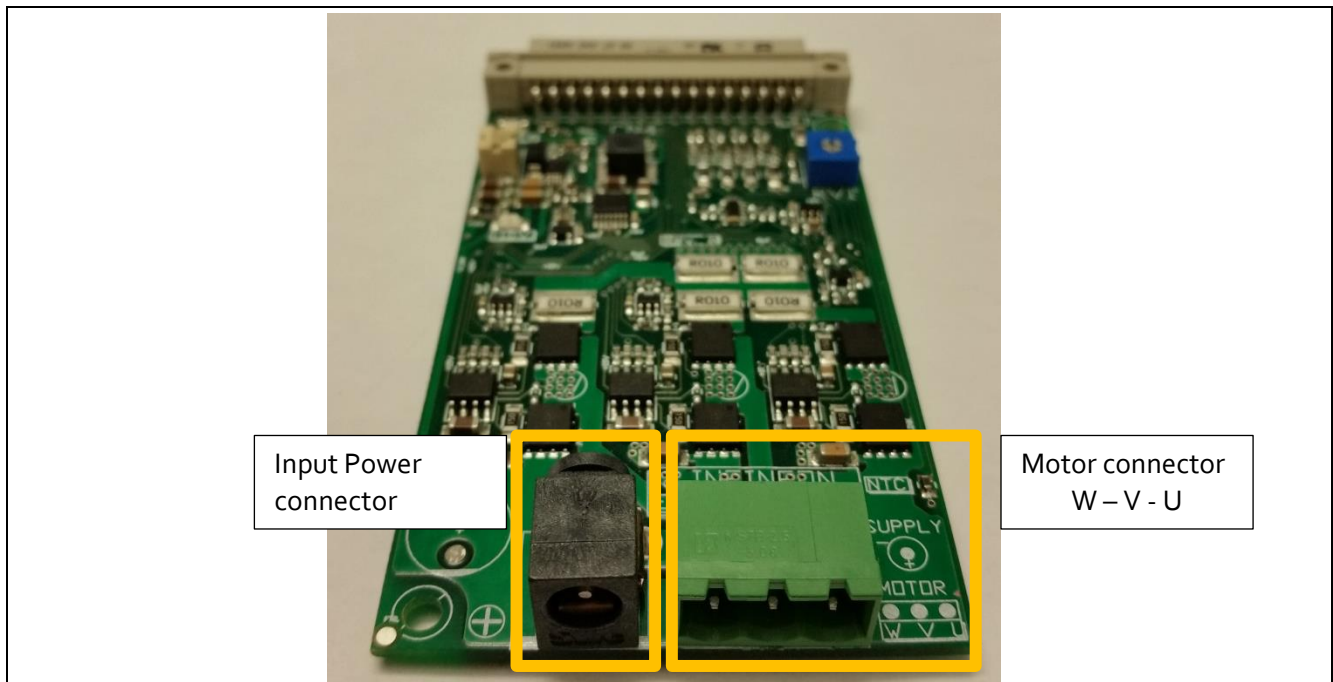

2 **Figure 5** Power Drivecard connector view

3 Motor connections are available in the 3-pin power connector shown on the right side of Figure 5.

4 **3.1.3 3-phase bridge**

5 The 3-phase MOSFET bridge in Figure 6 shows MOSFETs, gate resistors and shunts.

6 The U₃ comparator for overcurrent DC-link protection is also shown, providing a active-low FO (Fault) signal to
7 the microcontroller via XMC DriveCard signal connector.

8 Current trip is set by the resistor divider R₂₀/R₂₁ following Eq. 1.

$$V_{TH} = 2.5V \cdot \frac{R_{21}}{R_{21} + R_{20}} = 2.5V \cdot \frac{10K}{10K + 40K} = 0.5V \tag{Eq. 1}$$

$$I_{TRIP} = \frac{V_{TH}}{R_{SHUNT}} = \frac{0.5V}{0.02\ Ohm} = 25A$$

9 A single-pole filter (represented by R₁₉, C₂₇) is added to trim noise immunity.

10 Values are R₁₉=1KOhm, C₂₇=1nF.

1

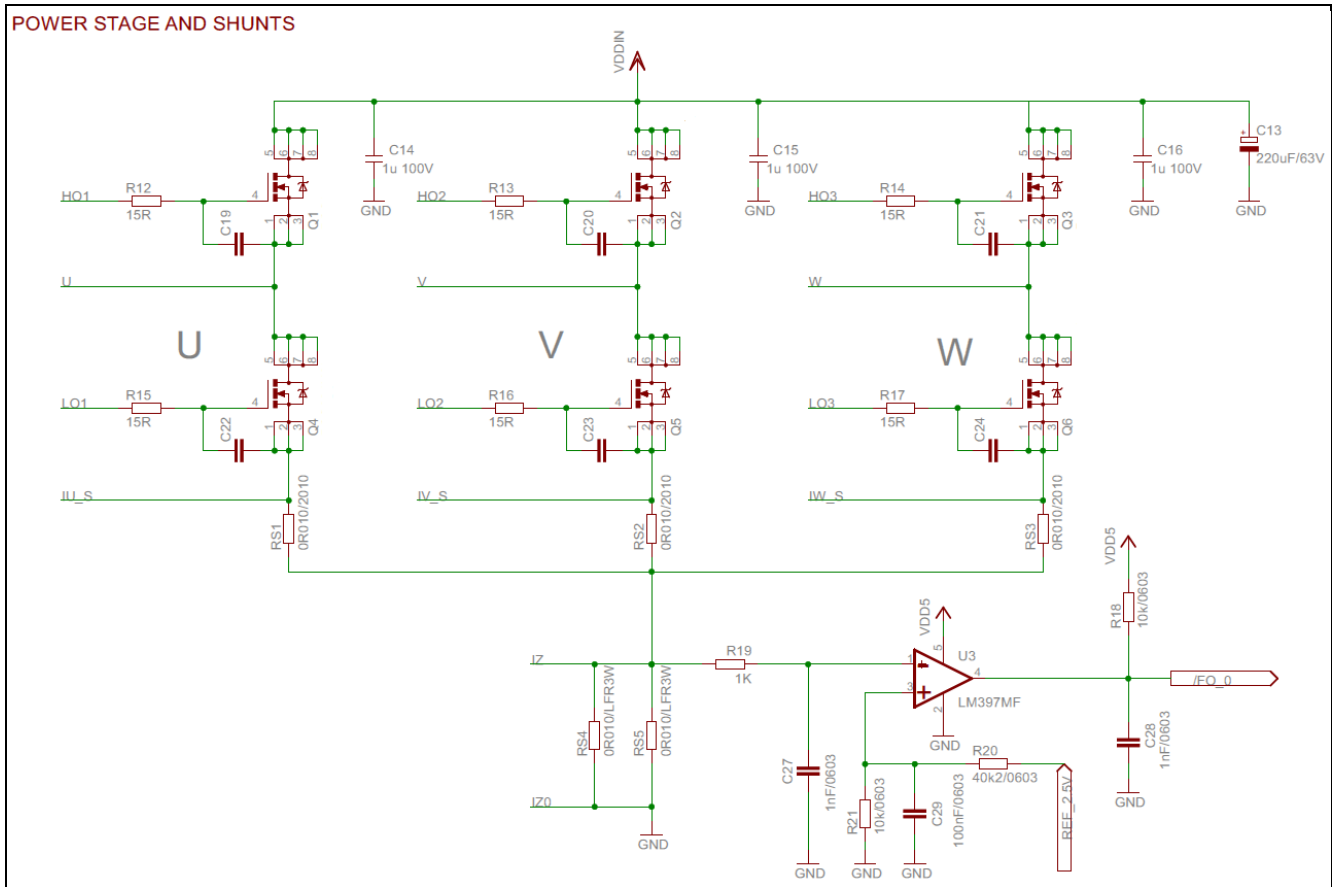

2 **Figure 6 3-phase MOSFET bridge**

3 Shunt voltages are fed into the DriveCard signal connector at I_U, I_V, I_W, I_DC_LINK_o pins as shown in
 4 Table 2.

5 Signal amplifiers are set as follows for emitter-shunt sensing (refer to Figure 7, I_U, I_V, I_W signals):

$$Gain_{I_U} = \frac{I_U}{I_{motor}} = 12 \cdot R_{s1} = \frac{[V]}{[A]} \tag{Eq. 2}$$

$$Offset_{I_U} = VREF_2.5V = 2.5V$$

6 While for Bus-shunt sensing (refer to Figure 8, I_DC_LINK_o signal):

$$Gain = \frac{I_U}{I_{motor}} = 12 \cdot R_{s4} // R_{s4} = \frac{[V]}{[A]} \tag{Eq. 3}$$

$$Offset = VREF_2.5V = 2.5V$$

7 I_DC_LINL_AVG, averaged version of the I_DC_LINK_o, is available as well at connector.

1

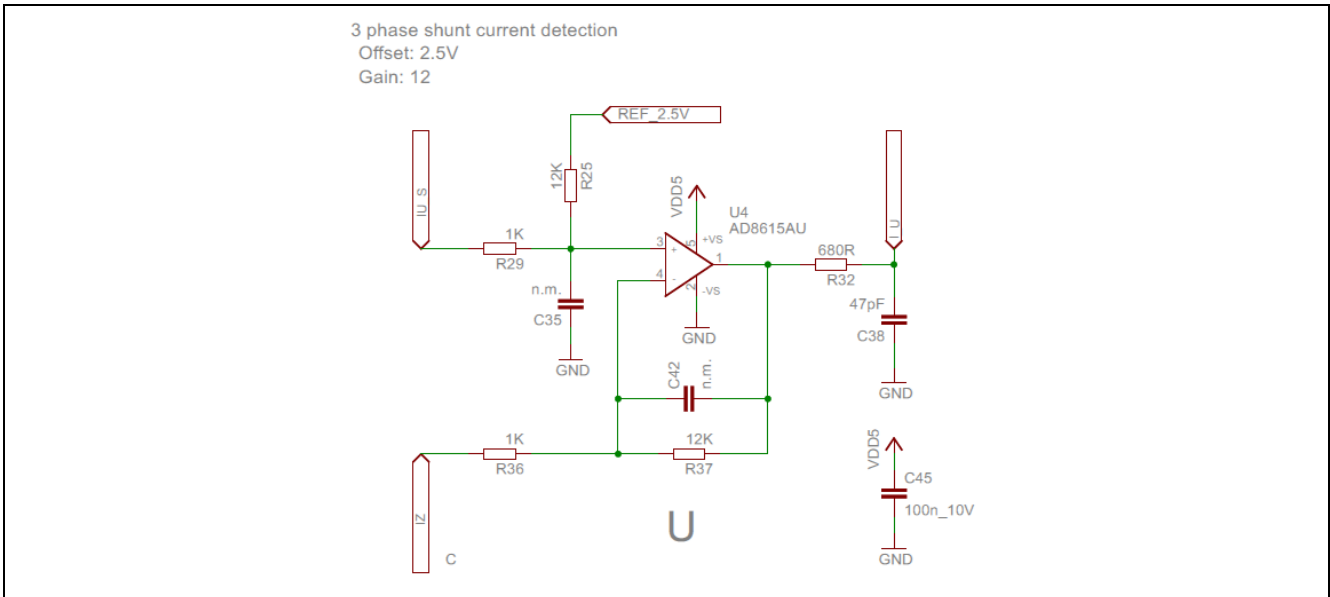

2 **Figure 7 Emitter-shunt current amplifier (U phase shown)**

3

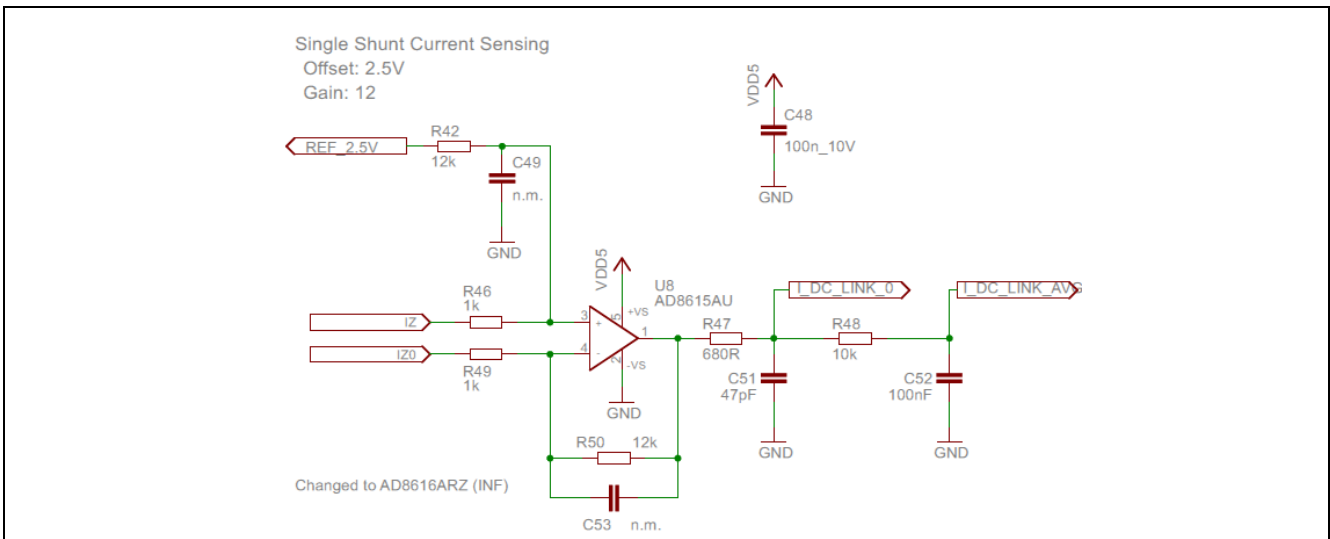

4 **Figure 8 DC Bus current sensing**

5 **3.1.4 DC bus Voltage sensing**

6 DCbus (DC_LINK) voltage is available at DC_LINK_DIV_X, CN4-B13 connector pin.

7 Voltage at pin is clamped to 5V1.

8 Resistor divider is set to:

9 R45=5.6k; R43=56k

$$DC_LINK_DIV_X = DCbus \cdot \frac{R45}{R45 + R43} \tag{Eq. 4}$$

$$\text{@24V Bus voltage: } DC_LINK_DIV_X = 24V \cdot \frac{5.6k\Omega}{5.6k\Omega + 56k\Omega} = 2.18V$$

$$\text{@42V Bus voltage: } DC_LINK_DIV_X = 42V \cdot \frac{5.6k\Omega}{5.6k\Omega + 56k\Omega} = 3.81V$$

1
2

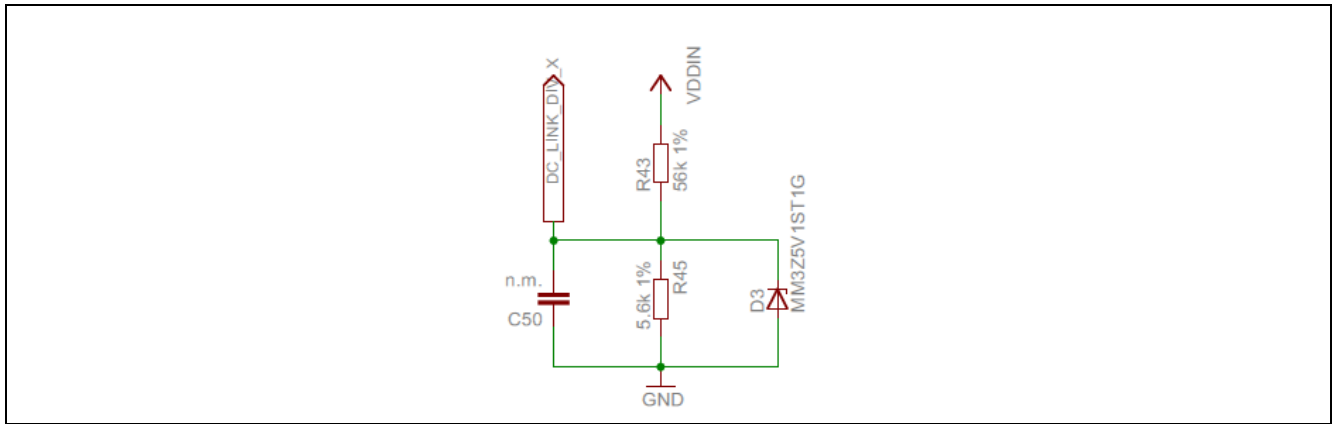

3 **Figure 9 DC bus sensing divider**

4 **3.1.5 Phase voltage sensing**

5 Phase voltage sensing is available at BEMF_U, BEMF_V, BEMF_W pins of the signal connector as mentioned
6 in Table 2.

$$BEMF_U = U \cdot \frac{R54}{R54 + R51} \tag{Eq. 5}$$

7 Phase voltage sensing is available for sensorless BLDC scalar control using 6-step modulation scheme as well
8 as for various other scopes.

9 Pin voltage is clamped by a 5.1V Zener to protect the uC pin.

10 Consider that the Zener diode might have considerable capacitive behavior and it might be needed to remove
11 them from the board.
12

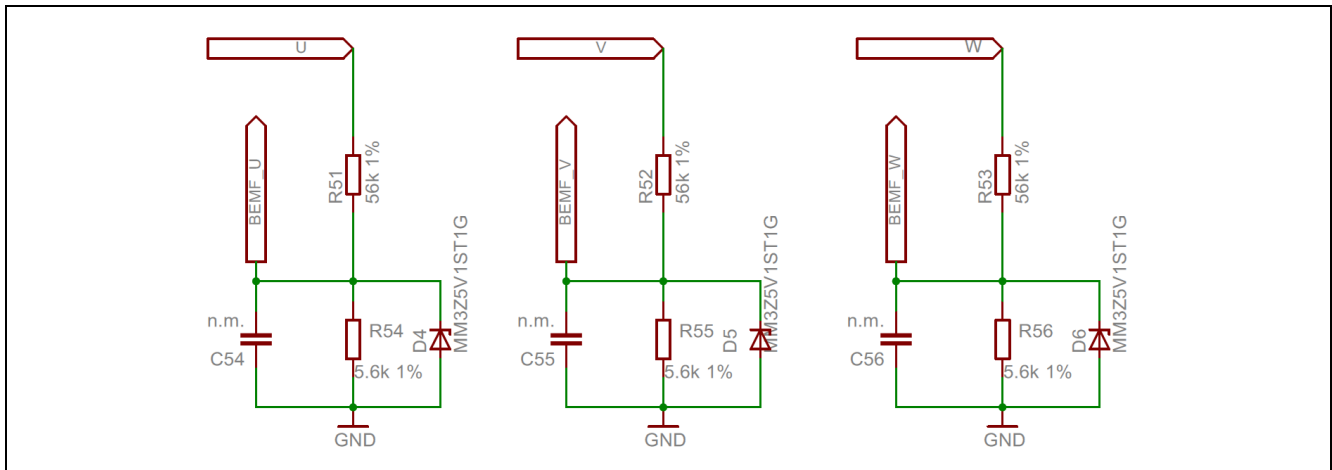

13 **Figure 10 Phase voltage sensing divider**

14 **3.1.6 DC/DC converters**

15 The present board embeds two step-down converters.

16 The first one brings BCbus voltage down to 12V and it is shown in Figure 11.

17 The second one brings the supply to the uC and analog circuits from 12V to 5V (Figure 12).
18

1

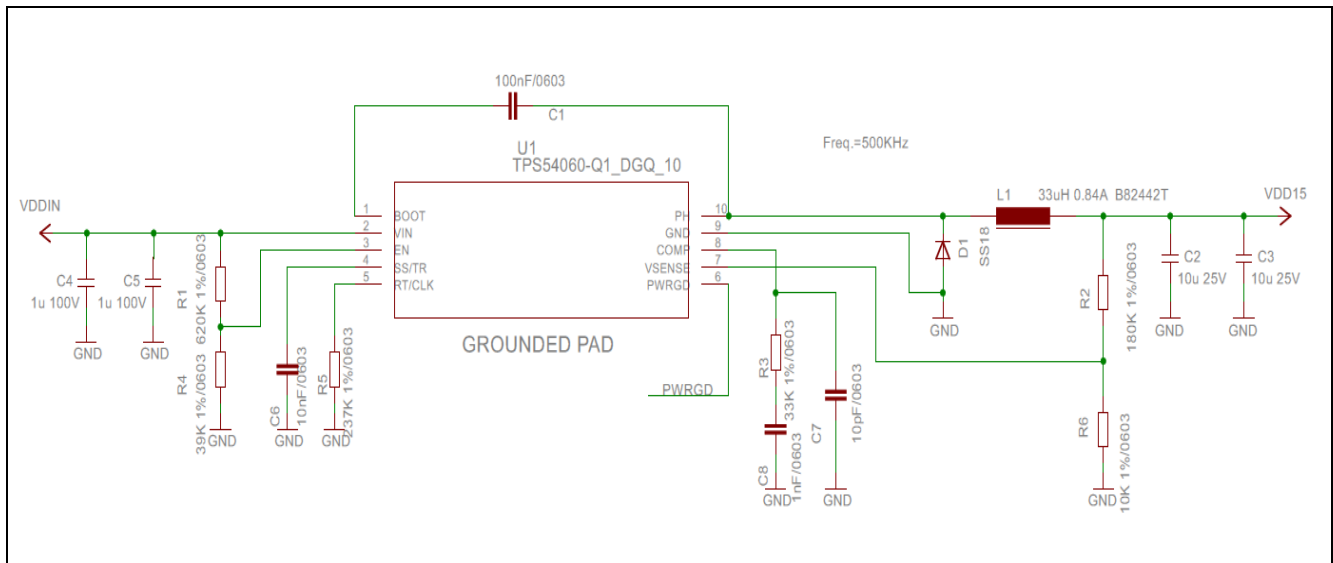

2 **Figure 11 Step-down converter from DCbus to 12V**

3

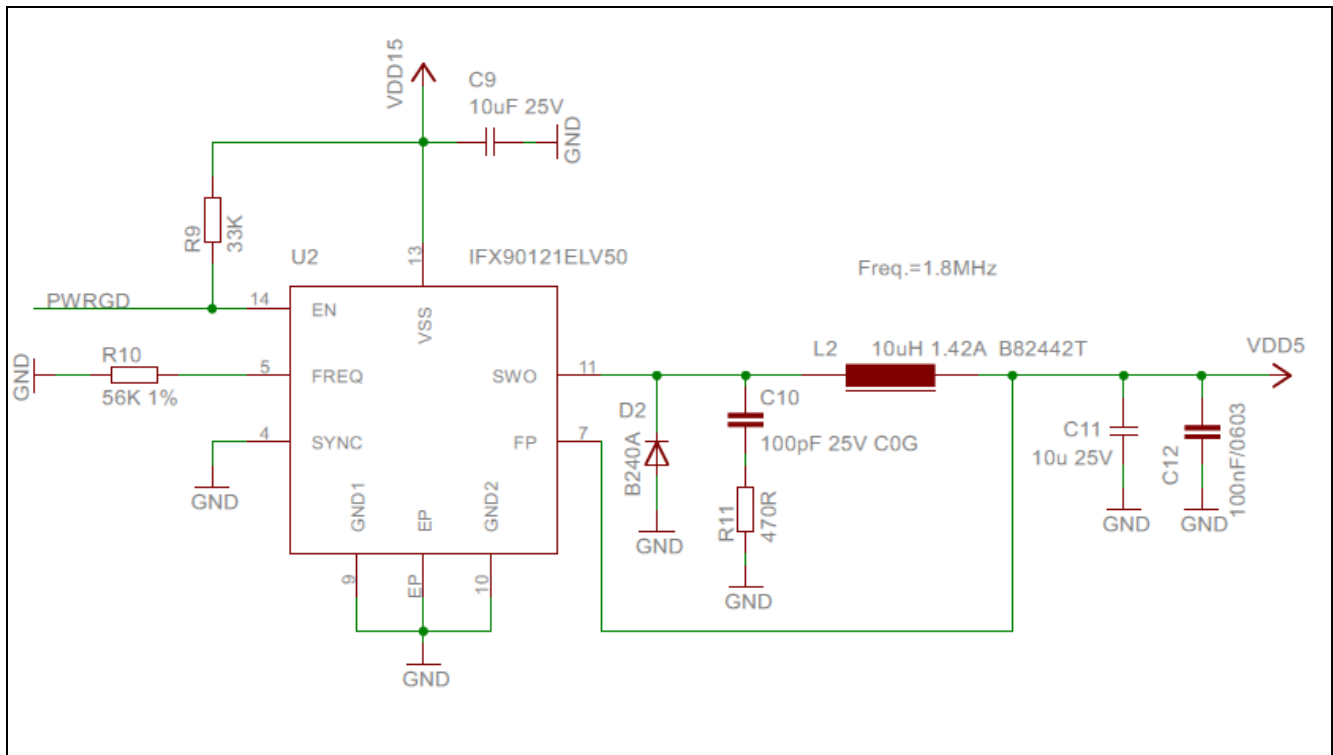

4 **Figure 12 Step-down converter from 12V to 5V**

5 **3.1.7 Miscellaneous**

6 Two GREEN light LEDs indicate presence of 12V and 5V supply. They both must be turned on when board is
7 operative.

8

9 One LED connected to /ENABLE_o pin of the signal connector is available as general purpose indicator for the
10 uController. See Figure 13.

11

1

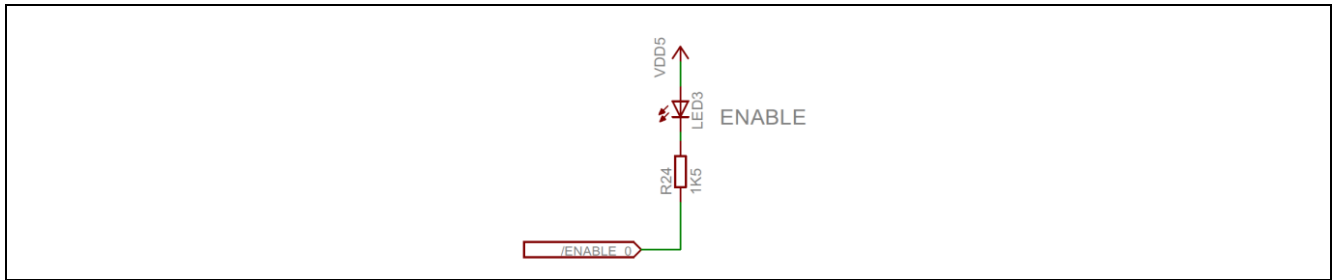

2 **Figure 13** ENABLE general purpose LED

3 A general purpose MANUAL Trimmer is also available on the board, connected to RVAR (see Table 2).
 4 RV1 is a 10KOhm trimmer, which ranges from 0V to VREF=5V.
 5

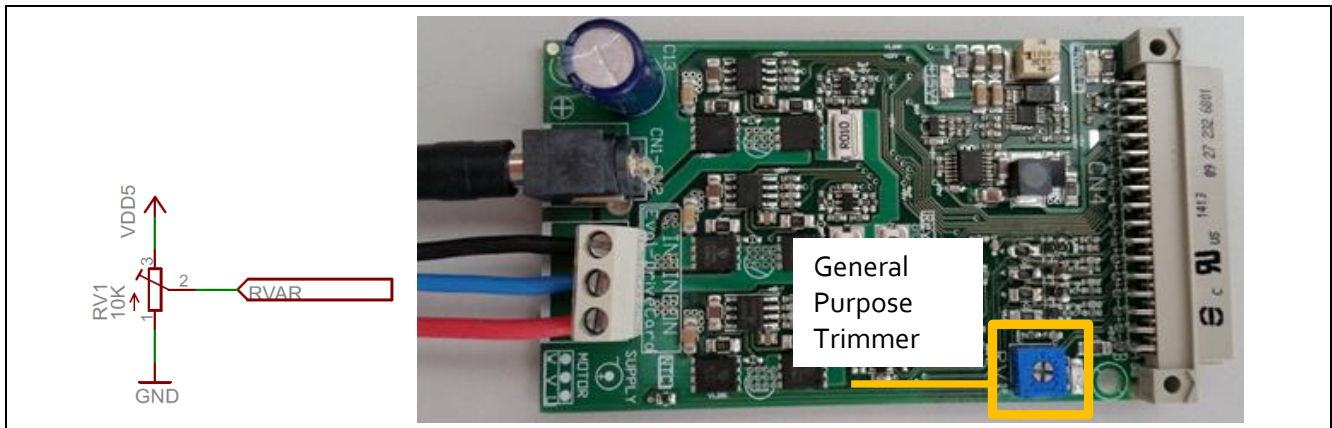

6

7 NTC thermistor is available as well, with the temperature dependence shown in Figure 14:

$$R = R_0 \cdot e^{B \cdot \left(\frac{1}{T} - \frac{1}{T_0}\right)} = \frac{R54}{R54 + R51} \tag{Eq. 6}$$

8

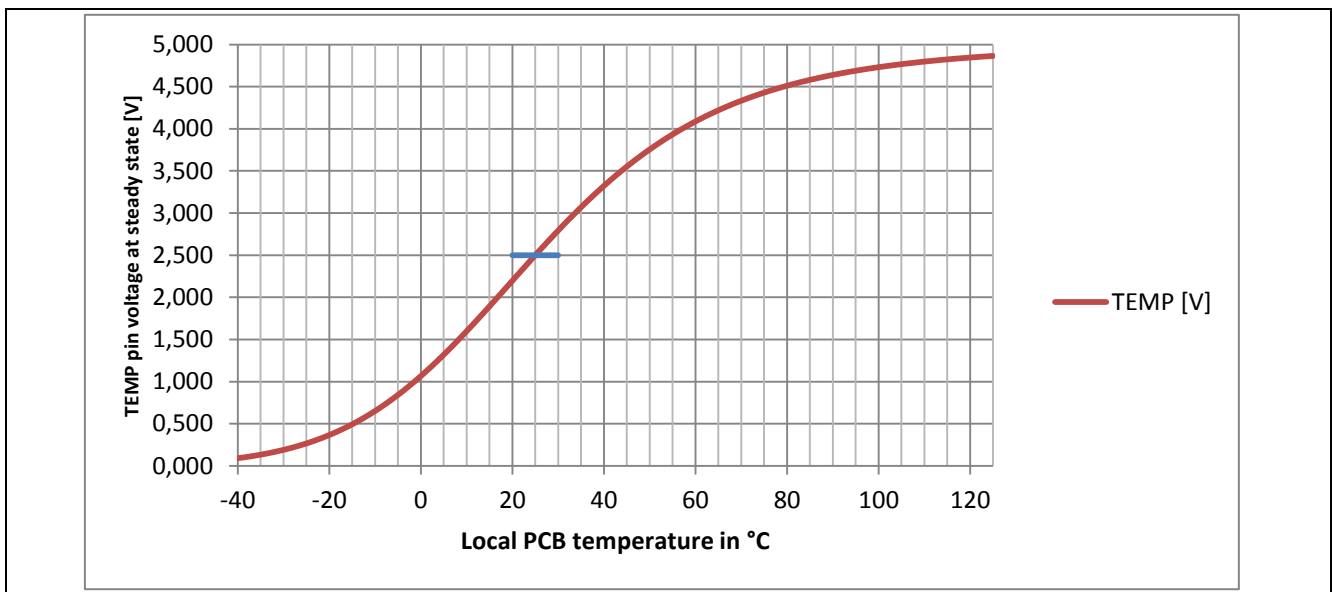

9 **Figure 14** TEMP pin voltage as a function of local PCB temperature

10

User Manual

Hardware description

1 NTC thermistor is located as shown in Figure 15

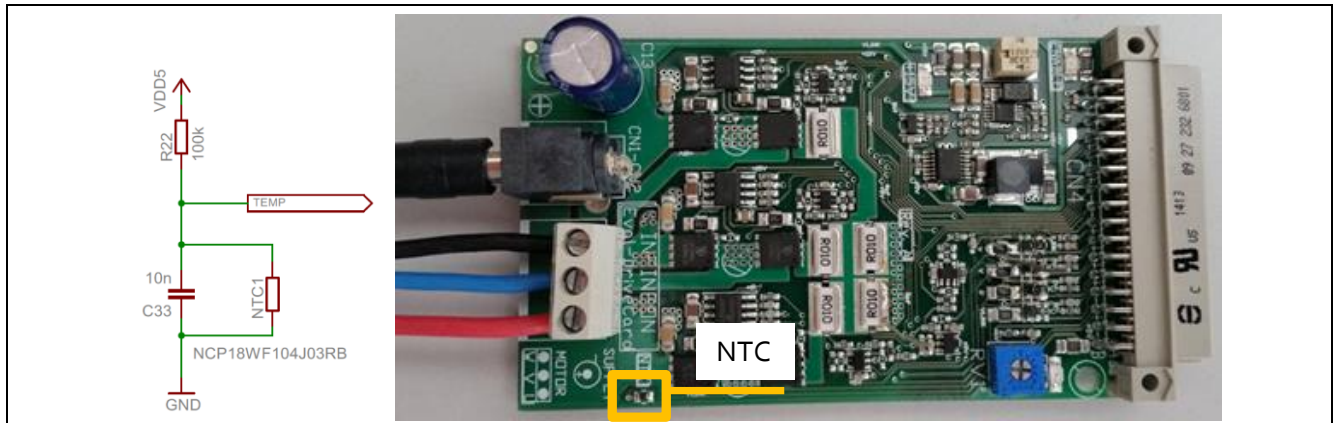

2 **Figure 15 Position of the NTC thermistor**

3 Therimistor capability to sense real mosfet temperature is very limited. It can be used just to have a superficial
4 indication of local PCB temperature.

5 **3.1.8 PWM signals**

6 This board uses as gate driver IC the Compact series EiceDriver™ 2EDL05No6PF. For detailed specification,
7 please visit www.infineon.com/EiceDriver and look for Isolated Gate Driver ICs.

8 The main characteristics of the Gate Driver IC follow:

- 9
- 10 • Technology: Rugged SOI (Silicon on Isolator) technology, allows negative voltage spikes at VB pin
- 11 • Outoput: +360/-700mA gate drive output current capability
- 12 • Protection: Interlocking function with minimum deadtime insertion (typ 75ns)
- 13 • UVLO: Mosfet tailored Under Voltage Lock Out (rising 9.1V, falling 8.3V typ), suitable for 12V driving
- 14 voltage
- 15 • Bootstrap: Low Ohminc Integrated bootstrap diode
- 16

17 In order to drive correctly the mosfet stage, please follow the suggested parameter choice:

18 **Table 3 Motor Control configuration**

Parameter	Value	Units
Deadtime	>500	ns
Switch delay time	400	ns
Polarity	Active high all PWMs	
Amplifier gain	12	V/V
DCLink Voltage divider ratio	0.909 or 9.09%	
Enable pin is DEACTIVATED	Active high → Led ON	

19
20
21
22 [1] A Reference. See the code examples at www.infineon.com