

KITPT2000FRDM3C Evaluation Board

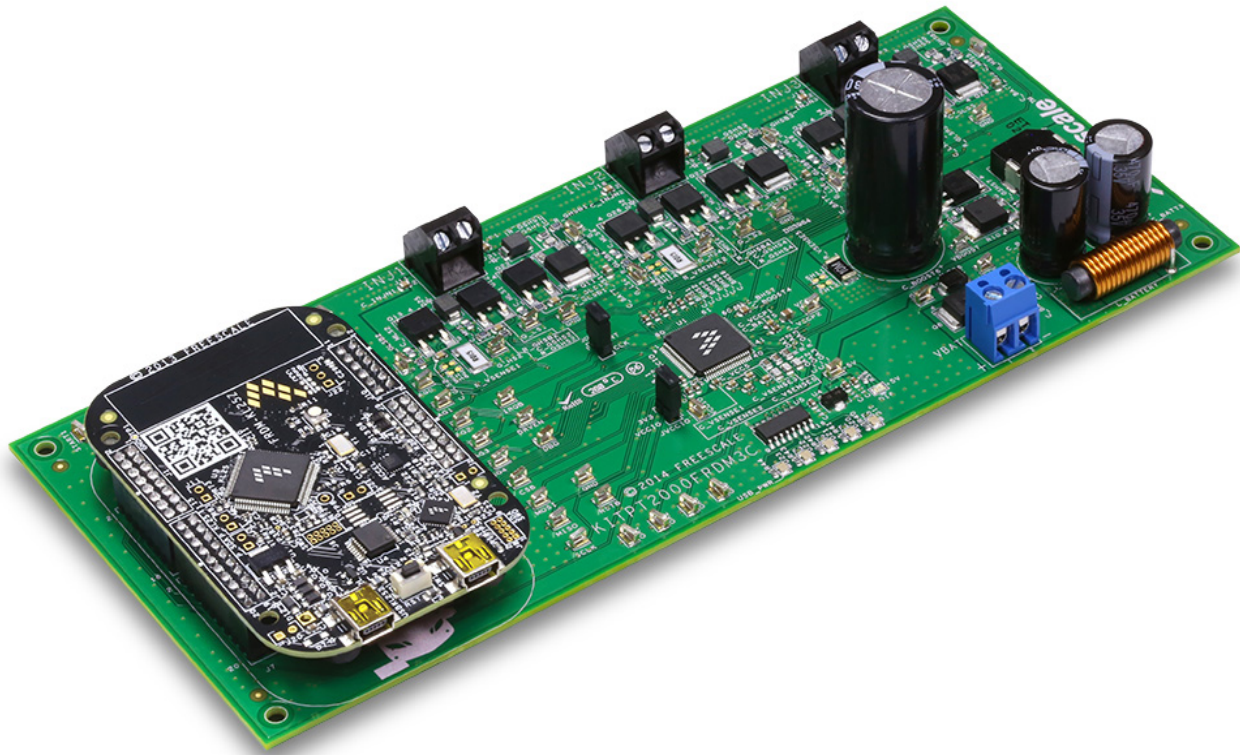

Figure 1. KITPT2000FRDM3C Evaluation Board



Contents

1	Important Notice	3
2	Getting Started	4
2.1	Kit Contents/Packing List	4
2.2	Jump Start	4
2.3	Required Equipment and Software	4
2.4	System Requirements	4
3	Understanding the System	5
3.1	Block Diagram	5
3.2	FRDM-KL25Z Freedom Development Platform	6
3.3	Connecting the FRDM-KL25Z Freedom Development Platform	7
4	Getting to Know the Hardware	8
4.1	Board Overview	8
4.2	Board Features	8
4.3	FRDM-KL25Z Features	8
4.4	Board Description	9
4.5	MC33PT2000 DC/DC Optional Freewheeling	10
4.6	Optional Freewheeling on VBAT High-side	11
4.7	LED Display	11
4.8	Test Point Signal Definitions	11
4.9	Pin Jumpers	12
4.10	MC33PT2000 EVB Connectors	12
4.11	Freedom Board FRDM - KL25Z Connectors	13
5	Installing the Software and Setting Up the Hardware	14
5.1	Installing SPIGen Freeware On Your Computer	14
5.2	Configuring the Hardware	15
5.3	Step-by-step Instructions for Setting Up the Hardware Using SPIGen	15
5.4	Running an Example Program	16
5.5	Running the Example Batch Files	16
5.6	Typical Peak and Hold scope Image	17
6	Troubleshooting	18
7	Schematics	19
8	Silkscreen	21
8.1	Silkscreen Top	21
9	Bill of Materials	22
10	References	25
10.1	Support	25
10.2	Warranty	25
11	Revision History	26

1 Important Notice

Freescale provides the enclosed product(s) under the following conditions:

This evaluation kit is intended for use of ENGINEERING DEVELOPMENT OR EVALUATION PURPOSES ONLY. It is provided as a sample IC pre-soldered to a printed circuit board to make it easier to access inputs, outputs, and supply terminals. This EVB may be used with any development system or other source of I/O signals by simply connecting it to the host MCU or computer board via off-the-shelf cables. This EVB is not a Reference Design and is not intended to represent a final design recommendation for any particular application. Final device in an application will be heavily dependent on proper printed circuit board layout and heat sinking design as well as attention to supply filtering, transient suppression, and I/O signal quality.

The goods provided may not be complete in terms of required design, marketing, and or manufacturing related protective considerations, including product safety measures typically found in the end product incorporating the goods. Due to the open construction of the product, it is the user's responsibility to take any and all appropriate precautions with regard to electrostatic discharge. In order to minimize risks associated with the customers applications, adequate design and operating safeguards must be provided by the customer to minimize inherent or procedural hazards. For any safety concerns, contact Freescale sales and technical support services.

Should this evaluation kit not meet the specifications indicated in the kit, it may be returned within 30 days from the date of delivery and will be replaced by a new kit.

Freescale reserves the right to make changes without further notice to any products herein. Freescale makes no warranty, representation or guarantee regarding the suitability of its products for any particular purpose, nor does Freescale assume any liability arising out of the application or use of any product or circuit, and specifically disclaims any and all liability, including without limitation consequential or incidental damages. "Typical" parameters can and do vary in different applications and actual performance may vary over time. All operating parameters, including "Typical", must be validated for each customer application by customer's technical experts.

Freescale does not convey any license under its patent rights nor the rights of others. Freescale products are not designed, intended, or authorized for use as components in systems intended for surgical implant into the body, or other applications intended to support or sustain life, or for any other application in which the failure of the Freescale product could create a situation where personal injury or death may occur.

Should the buyer purchase or use Freescale products for any such unintended or unauthorized application, the buyer shall indemnify and hold Freescale and its officers, employees, subsidiaries, affiliates, and distributors harmless against all claims, costs, damages, and expenses, and reasonable attorney fees arising out of, directly or indirectly, any claim of personal injury or death associated with such unintended or unauthorized use, even if such claim alleges that Freescale was negligent regarding the design or manufacture of the part. Freescale™ and the Freescale logo are trademarks of Freescale Semiconductor, Inc. All other product or service names are the property of their respective owners.

© Freescale Semiconductor, Inc. 2015.

2 Getting Started

2.1 Kit Contents/Packing List

The **KITPT2000FRDM3C** contents include:

- Assembled and tested evaluation board in an anti-static bag
- Quick Start Guide, Analog Tools
- Warranty card
- USB cable to connect KL25Z to computer

2.2 Jump Start

Freescale's analog product development boards help to easily evaluate Freescale products. These tools support analog mixed signal and power solutions including monolithic ICs using proven high-volume SMARTMOS mixed signal technology, and system-in-package devices utilizing power, SMARTMOS and MCU dies. Freescale products enable longer battery life, smaller form factor, component count reduction, ease of design, lower system cost and improved performance in powering state of the art systems.

- Go to www.freescale.com/analogtools
- Locate the kit
- Review the Tool Summary Page
- Look for



- Download documents, software, and other information

Once the files are downloaded, review the user guide in the bundle. The user guide includes setup instructions, BOM and schematics. Jump start bundles are available on each tool summary page with the most relevant and current information. The information includes everything needed for design.

2.3 Required Equipment and Software

To use this kit, you need:

- 12 V power supply with current limit set initially to 4.0 A
- Oscilloscope (four-channel preferably) with current probe(s) (10 MHz bandwidth)
- SPIGen 7.0 or greater www.freescale.com/analogtools

2.4 System Requirements

The kit requires the following to function properly with the software:

- USB-enabled PC with Windows® XP or higher

3 Understanding the System

The KITPT2000FRDM3C uses the Freedom board KL25Z to communicate with the MC33PT2000 through the SPI to setup registers and flash CRAM and DRAM. The KL25Z also controls the start and end of injection using the STARTx pins. This particular application drives three injectors, two fuel pumps, and an external DC/DC.

3.1 Block Diagram

The high level system block diagram (Figure 2) outlines the way the Freescale standard products are used to implement this particular application of three cylinders (INJ1, INJ2 and INJ3) with freewheeling and one DCDC. Communication between the KL25Z and MC33PT2000 is done by SPI, control and reporting is done through I/Os.

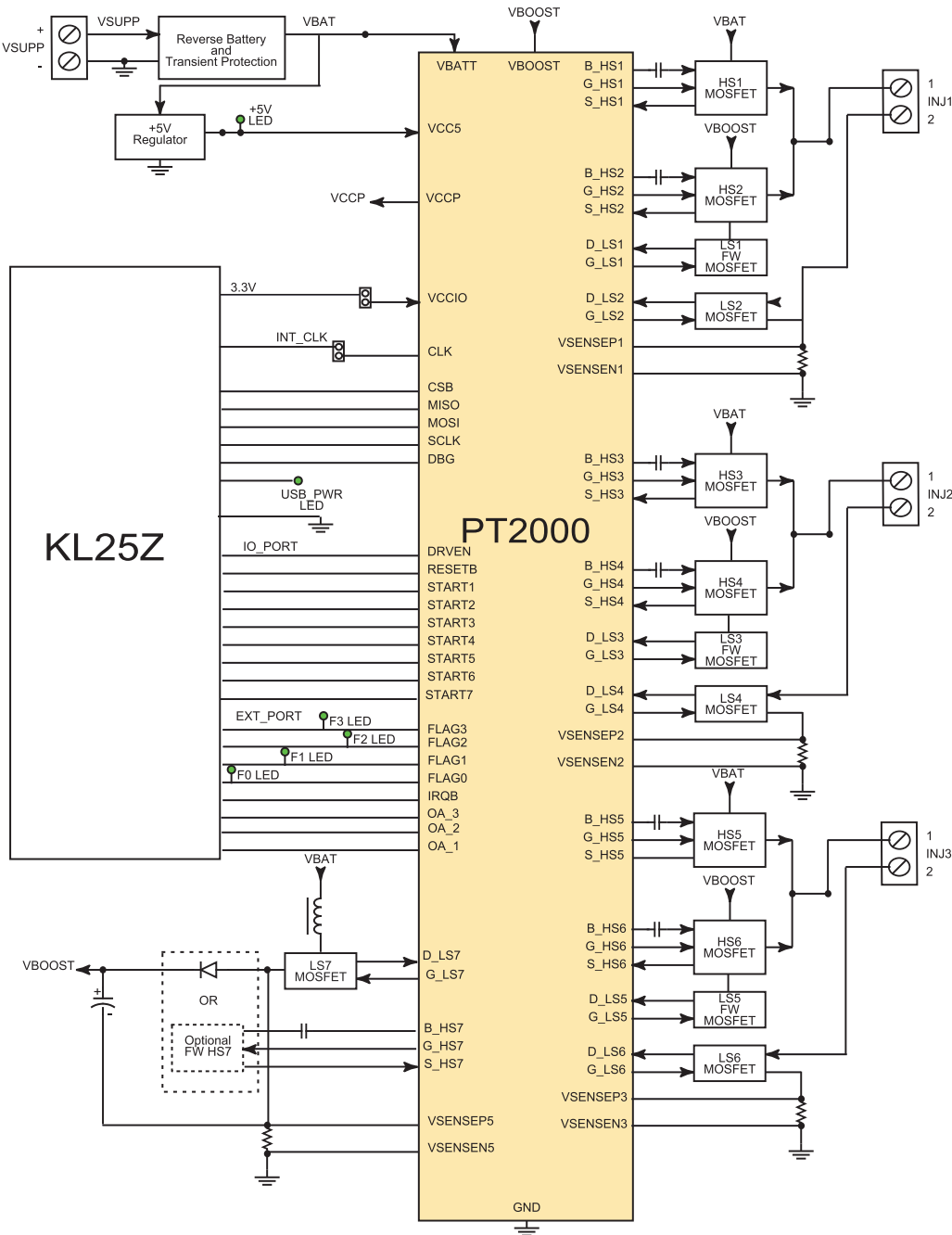

Figure 2. Block Diagram

3.1.1 Device Features

This evaluation board features the following Freescale products:

Table 1. MC33PT2000 Device Features

Device	Description	Features
MC33PT2000	Programmable Solenoid Controller, 7 high-sides and 8 low-sides	<ul style="list-style-type: none"> Battery voltage range, $5.5\text{ V} < V_{\text{BATT}} < 32\text{ V}$ ⁽¹⁾ Pre-drive operating voltage up to 72 V High-side/low-side pre-drive PWM capability up to 100 kHz All pre-drivers with four selectable slew rates Eight selectable, pre-defined VDS monitoring thresholds Encryption for microcode protection Integrated 1.0 MHz backup clock

Notes

- If $V_{\text{SUPP}} > 16\text{ V}$, it is highly recommended to disable the internal V_{CCP} regulator and externally supply V_{CCP} .

3.2 FRDM-KL25Z Freedom Development Platform

The Freescale Freedom development platform is a set of software and hardware tools for evaluation and development. It is ideal for rapid prototyping of microcontroller-based applications. The Freescale Freedom KL25Z hardware, FRDM-KL25Z, is a simple, yet sophisticated design featuring a Kinetis L Series microcontroller, the industry's first microcontroller built on the ARM® Cortex™-M0+ core.

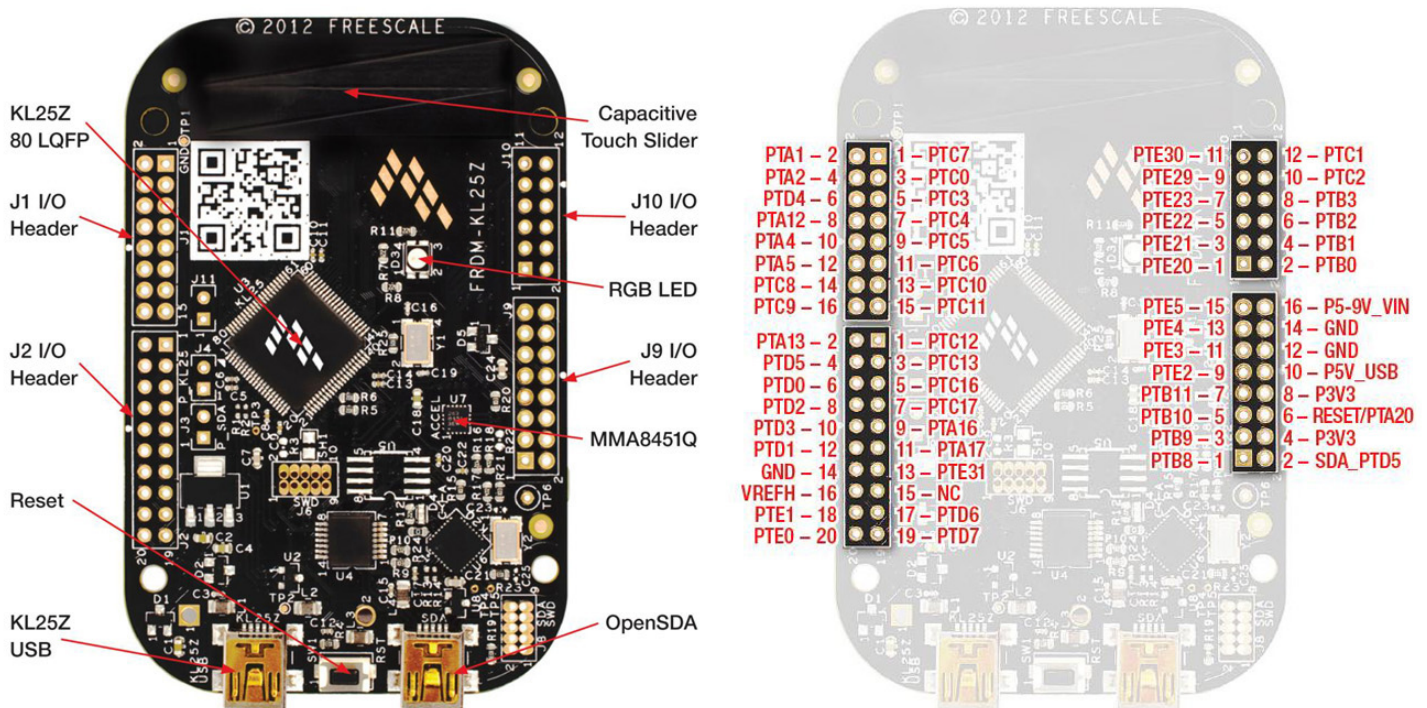

Figure 3. FRDM-KL25Z

3.3 Connecting the FRDM-KL25Z Freedom Development Platform

KITPT2000FRDM3C includes a KL25Z already flashed to use as a SPI dongle to control the MC33PT2000. A USB cable from a USB host to the KL25Z mini-B USB connector and SPIGEN (7.xx and above) are all that are needed to use the kit.

The following chapters, [Section 3.3.1, Installing the Drivers \(Optional\)](#), page 7 through [Section 3.3.4, Using the MSD Flash Programmer \(Optional\)](#), page 7 are optional and only required if a software update is needed, or if the user wants to reprogram the KL25Z to develop their own application.

3.3.1 Installing the Drivers (Optional)

To flash the Freedom board using drag and drop from Windows Explorer, USB Drivers, and OpenSDA Firmware (MSD & Debug) from P&E Micro www.pemicro.com/opensda must be loaded on the board.

3.3.2 Enter OpenSDA Bootloader Mode (Optional)

1. Unplug the USB cable if attached.
2. Press and hold the Reset button (SW1).
3. Plug in a USB cable between a USB host and the OpenSDA USB connector (labeled SDAII).
4. Release the Reset button.

A removable drive is visible in the host file system with a volume label of BOOTLOADER. It is now in OpenSDA Bootloader mode.

3.3.3 Load an OpenSDA Application (Optional)

1. Locate the OpenSDA Applications folder from the downloaded zip file.
2. Copy and paste, or drag and drop the MSD Flash Programmer Application (MSD-FRDM-KL25Z_vXYZ_Pemicro.SDA) to the BOOTLOADER drive (Make sure to unzip the file before doing the paste or drop).
3. Unplug the USB cable and plug it into the SDA USB Connector. The new OpenSDA Application is now running and a FRDM-KL25Z drive visible in the host file system.

3.3.4 Using the MSD Flash Programmer (Optional)

1. Locate SPIGEN UsbSpiDongleKL25Z_pt2k.srec image folder in SPIGEN folder (C:\Program Files (x86)\SPIGen\SPI Dongle Firmware).
2. Copy and paste, or drag and drop the.srec file to the FRDM-KL25Z drive.
3. Unplug the USB cable from the open SDA USB Connector and plug it into the USB_KL25Z.

4 Getting to Know the Hardware

4.1 Board Overview

The KITPT2000FRDM3C is an easy-to-use circuit board allowing the user to exercise all the functions of the MC33PT2000 smart pre-driver circuit. A PC communicates to the evaluation board (EVB) through a Freedom board (FRDM-KL25Z) connected to the PC's USB port. The Freescale SPIGen program (version 7.0 and above) provides the user interface to the MC33PT2000 SPI port and allows the user to program the Code RAM and Data Registers, send commands to the IC, and receive status from the IC.

4.2 Board Features

The board features are as follows:

- MC33PT2000 direct injection pre-driver integrated circuit
- USB-to-SPI dongle interface using the FRDM-KL25Z
- External MOSFETs
- Power-conditioning circuitry
- +5.0 V regulator supplies all +5.0 V power required by the MC33PT2000 EVB
- +12 V V_{SUPP} provides the power to the MC33PT2000 and the loads

4.3 FRDM-KL25Z Features

The FRDM-KL25Z board features are as follows:

- MKL25Z128VLK4 MCU - 48 MHz, 128 KB Flash, 16 KB SRAM, USB OTG (FS), 80LQFP
- Capacitive touch slider, MMA8451Q accelerometer, Tri-color LED
- Flexible power supply options - USB, coin cell battery, external source
- Easy access to MCU I/O
- Battery-ready, power-measurement access points
- Form factor compatible with Arduino™ R3 pin layout
- New, OpenSDA debug interface
- Mass storage device flash programming interface (default) - no tool installation required to evaluate demonstration applications
- P&E Debug interface provides run-control debugging and compatibility with IDE tools
- CMSIS-DAP interface: new ARM standard for embedded debug interface

Additional reference documents are available on www.freescale.com/FRDM-KL25Z

4.4 Board Description

The analog part consists of the MC33PT2000 chip controlling external drivers. The digital part consists of the KL25Z controlling the MC33PT2000 by the SPI and I/Os.

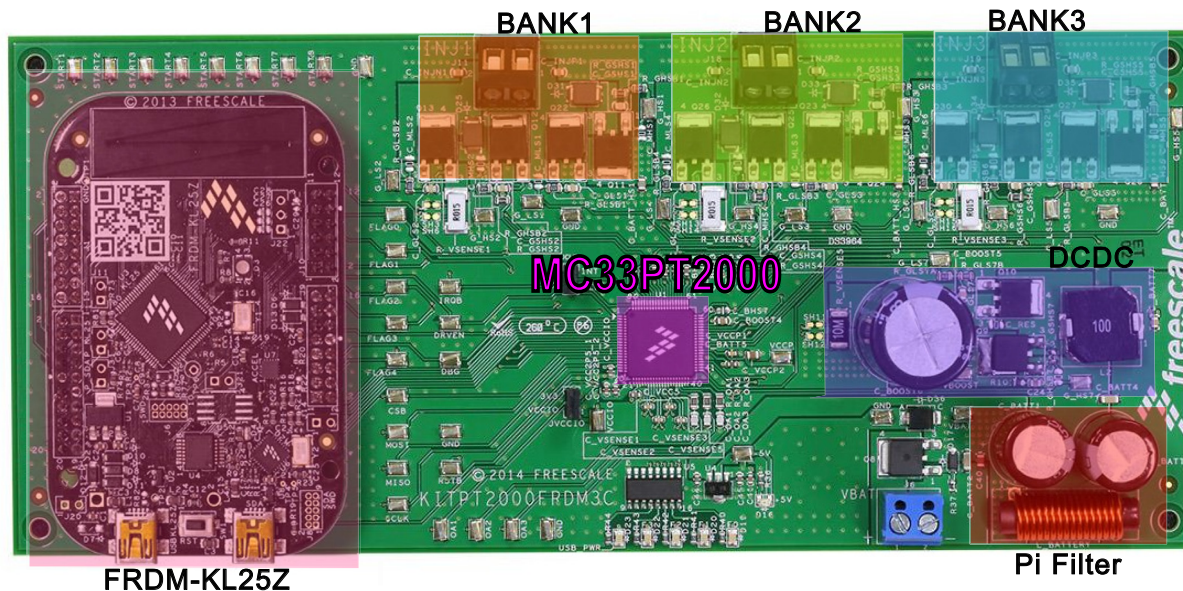

Figure 4. Board Description

Table 2. Board Description

Name	Description
KL25Z	Microcontroller used to communicate with the computer using a USB, and to the MC33PT2000 using the SPI
DCDC	DCDC converter to generate BOOST voltage
BANK1	Bank1: two high-side + one low-side to control injector 1 + 1 freewheeling low-side
BANK2	Bank2: two high-side + one low-side to control injector 2+ 1 freewheeling low-side
BANK3	Bank3: two high-side + one low-side to control injector 3+ 1 freewheeling low-side
MC33PT2000AE	Programmable solenoid controller
Pi Filter	Pi Filter circuits to remove unwanted or undesired frequencies

4.5 MC33PT2000 DC/DC Optional Freewheeling

The KITPT2000FRDM3C uses a DC/DC with a diode by default, which allows you to use the DC/DC automatic mode control (hysteretic, resonant) provided by the PT2000. It is possible to replace the diode with a MOSFET for power dissipation concerns. The three possible DC/DC configurations are shown in [Table 3](#). For more information on the hysteretic and resonant modes, refer to the PT2000 data sheet. The microcode example on the web controls the DC/DC in hysteretic mode. The board is built by default for this mode.

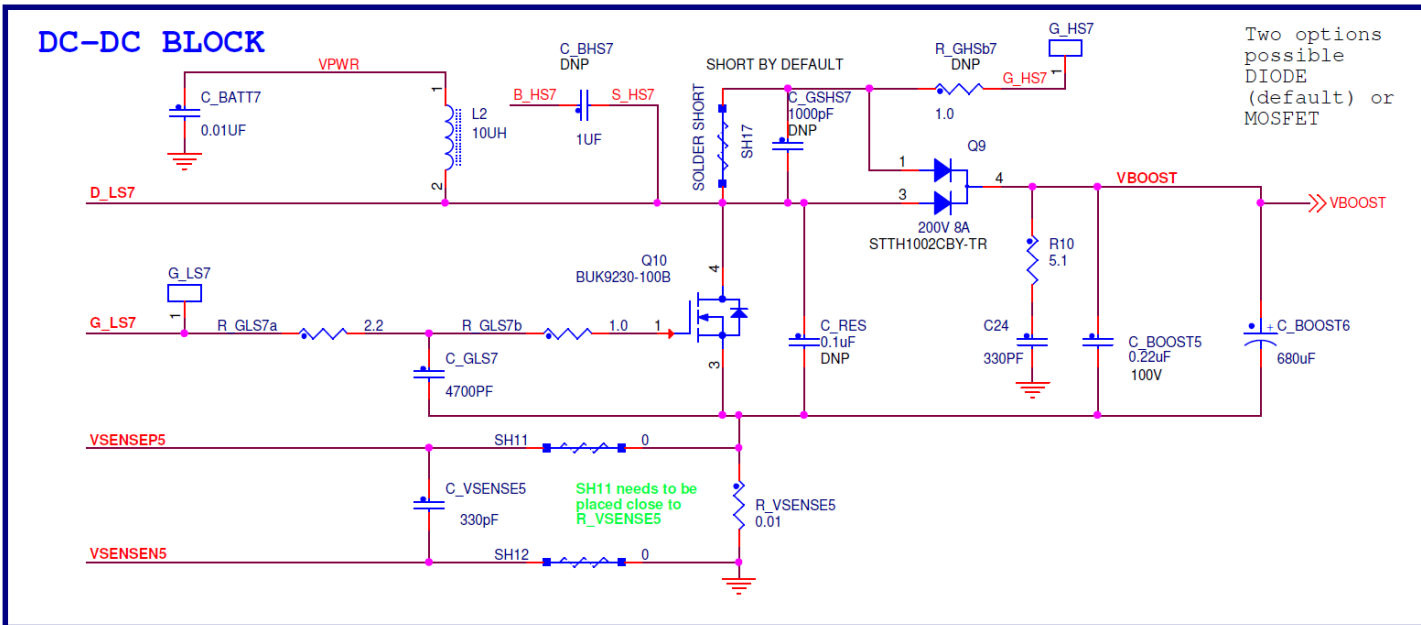

Figure 5. DCDC Different Configuration

Table 3. DC/DC Mode Versus Component Placement

DC/DC mode	Q9	C_GSHS7	R_CHSb7	C_RES	C_BHS7
Hysteretic (default)	Diode	Shorted	Do not place	Do not place	Do not place
Resonant	Diode	Shorted	Do not place	10 nF	Do not place
FW with MOSFET	MOSFET (BUK9230)	1.0 uF	1.0 ohms	Do not place	1.0 uF

13. MISO - SPI Master In Slave Out
14. SCLK - SPI CLK up to 10 MHz
15. G_LSx - Gate low side
16. G_HSx - Gate high-side
17. VCCP - V_{CCP} voltage
18. VCCIO - I/O voltage set to 3.3 V by default (JVCCIO)
19. 5.0 V - V_{CC5} voltage
20. VBOOST - V_{BOOST} voltage
21. VBAT - Battery voltage
22. OA1 to 3 - OAx test point for current recopy or I/Os
23. GND - Ground test points

4.9 Pin Jumpers

There are two jumper headers on the KITPT2000FRDM3C.

1. VCCIO_SEL - This is a header to supply V_{CCIO} from the +3.3 V regulator on the **KL25Z (3.3V logic)**. If not connected, no voltage goes through the I/Os
2. CLK_SEL - This is a header to select the KL25Z Oscillator which is set to 1 MHz. If not connected, the internal 1.0 MHz backup CLK is used.

4.10 MC33PT2000 EVB Connectors

4.10.1 Input Connector

There is one input connector used to connect the KITPT2000FRDM3C to +12 V.

1. (V_{SUPP}) +12 VOLT POWER SUPPLY INPUT -
 - Screw Terminal 1 (+) +12 V
 - Screw Terminal 2 (-) GND

4.10.2 Output Connectors

There are three output connectors that provide three injectors:

1. (INJ1) INJECTOR OUTPUT 1 -
 - Screw Terminal 1 - High-side drive
 - Screw Terminal 2 - Low-side drive
2. (INJ2) INJECTOR OUTPUT 2 -
 - Screw Terminal 1 - High-side drive
 - Screw Terminal 2 - Low-side drive
3. (INJ3) INJECTOR OUTPUT 3 -
 - Screw Terminal 1 - High-side drive
 - Screw Terminal 2 - Low-side drive

4.11 Freedom Board FRDM - KL25Z Connectors

The KL25Z board is to be plugged into the four male connectors J14 - 17, attached with the four female connectors are included in the kit and should be soldered directly on the KL25Z.

Table 4. EVB J8 Pinout (Connects to J1 on KL25Z)

Pin	SPIGen Signal	Pin	SPIGen Signal
J8 01	IRQ	J8 02	
J8 03	DBG	J8 04	
J8 05	CLK	J8 06	FLAG0
J8 07	FLAG1	J8 08	
J8 09	FLAG2	J8 10	
J8 11	FLAG3	J8 12	
J8 13		J8 14	
J8 15		J8 16	

Table 5. EVB J7 Pinout (Connects to J2 on KL25Z)

Pin	SPIGen Signal	Pin	SPIGen Signal
J7 01	DRVEN	J7 02	
J7 03	RESETB	J7 04	
J7 05	START1	J7 06	CSB
J7 07	START2	J7 08	MOSI
J7 09	START3	J7 10	MISO
J7 11	START4	J7 12	SCLK
J7 13	START5	J7 14	
J7 15		J7 16	
J7 17		J7 18	
J7 19	START6	J7 20	START7

Table 6. EVB J9 Pinout (Connects to J9 on KL25Z)

Pin	SPIGen Signal	Pin	SPIGen Signal
J9 01		J9 02	
J9 03		J9 04	3.3 V
J9 05		J9 06	
J9 07		J9 08	3.3 V
J9 09		J9 10	USB PWR
J9 11		J9 12	GND
J9 13		J9 14	GND
J9 15		J9 16	

Table 7. EVB J10 Pinout (Connects to J10 on KL25Z)

Pin	SPIGen Signal	Pin	SPIGen Signal
J10 01	OA1	J10 02	
J10 03	OA2	J10 04	
J10 05	OA3	J10 06	
J10 07		J10 08	
J10 09		J10 10	
J10 11		J10 12	

5 Installing the Software and Setting Up the Hardware

5.1 Installing SPIGen Freeware On Your Computer

The latest version of SPIGen is designed to run on Windows 8, Windows 7, Vista, or XP-based operating systems. To install the software, go to www.freescale.com/analogtools and select your kit. Click on that link to open the corresponding Tool Summary Page. Look for “Jump Start Your Design”. Download to your computer desktop the SPIGen software, as well as the associated configuration file.

Run the install program from the desktop. The Installation Wizard conducts the rest of the process.

To use SPIGen, go to the Windows Start menu, then Programs, then SPIGen, and click on the SPIGen icon. The SPIGen Graphic User Interface (GUI) appears. Go to the file menu in the upper left hand corner of the GUI, and select “Open”. In the file selection window that appears, set the “Files of type:” drop-down menu to “SPIGen Files (*.spi)”. (As an exceptional case, the file name may have a .txt extension, in which case, set the menu to “All Files (*.*)”.) Next, browse for the configuration file saved on the desktop earlier and select it. Click “Open”, and SPIGen creates a specially configured SPI command generator for your evaluation board.

The GUI is shown in **Figure 7**. The text at the top is the name of the configuration file loaded. The left side panel displays folders grouping user interfaces. The interfaces in the pre-installed MC33PT2000 folder pertain specifically to the board under discussion. The process of loading the configuration file has assigned a list of “Extra Pins” as well as a list of “Quick Commands”, all of which are board-specific.

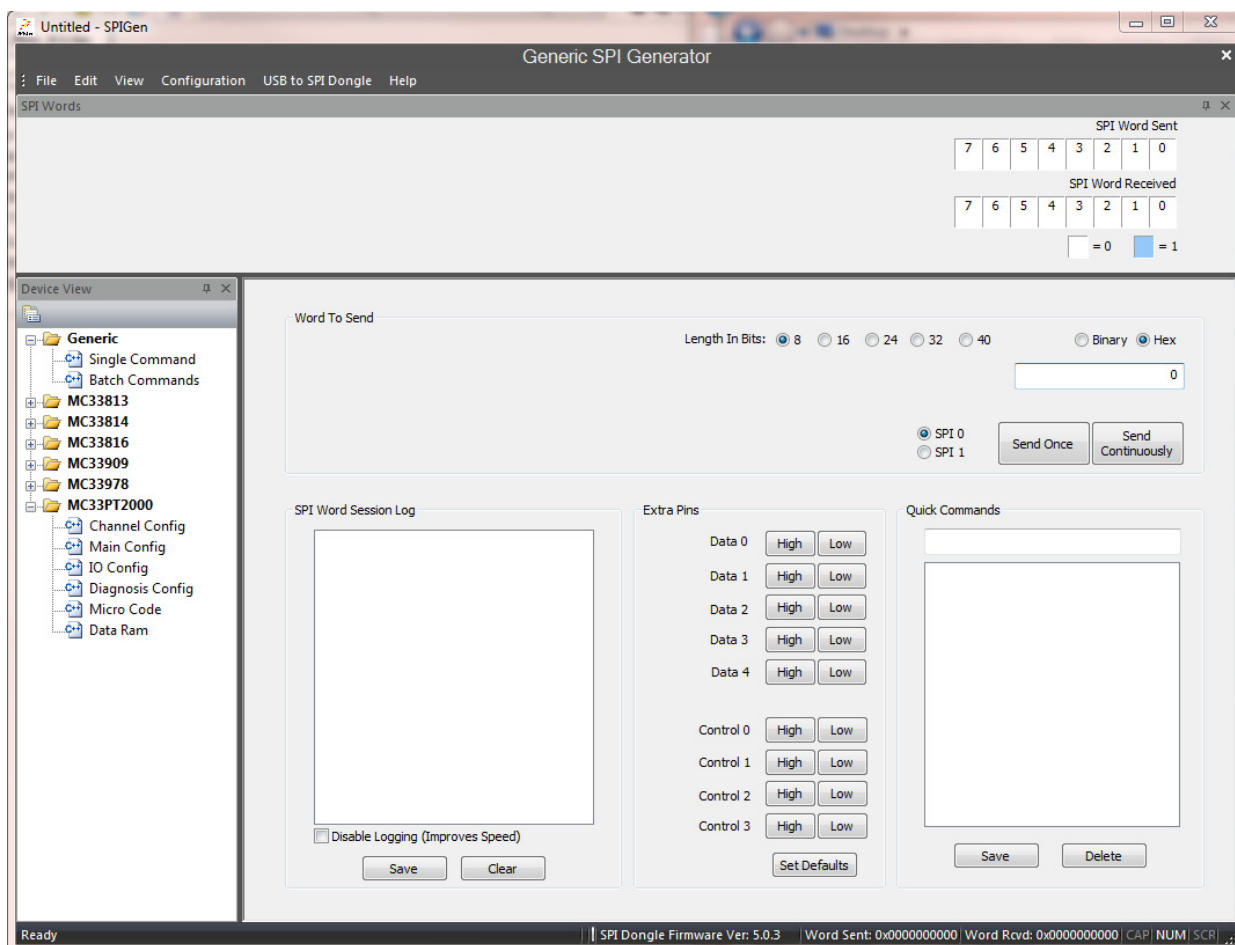

Figure 7. SPIGen GUI

5.2 Configuring the Hardware

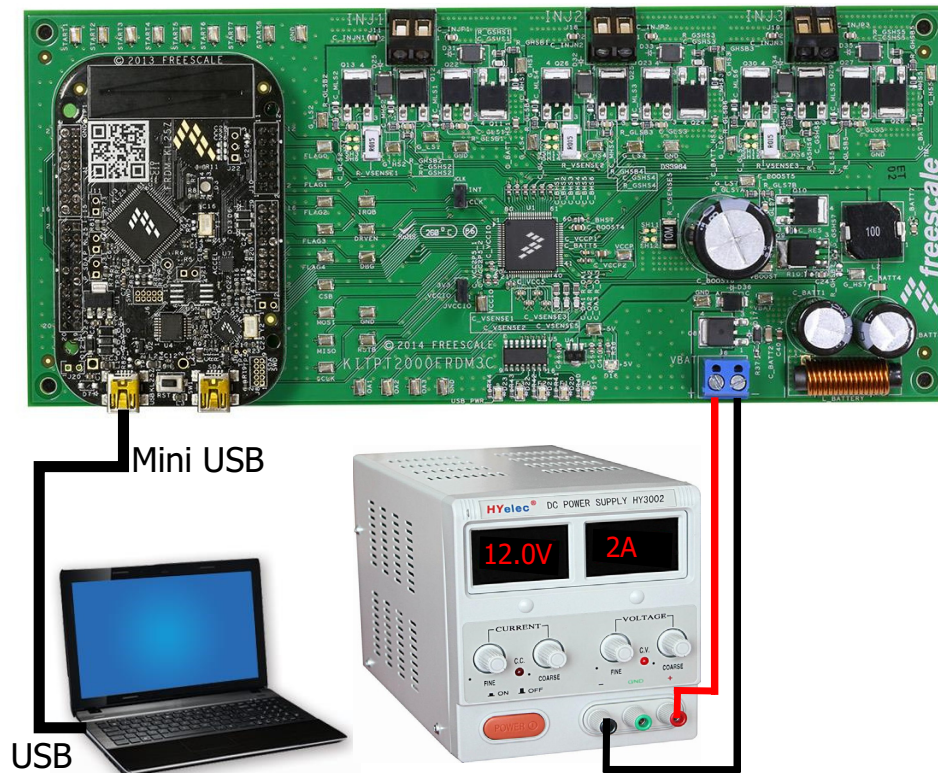

Figure 8. KITPT2000FRDM3C Board Setup

5.3 Step-by-step Instructions for Setting Up the Hardware Using SPIGen

the following connections and setup must be performed to use the examples included in the software bundle:

1. Make sure SPIGen 7.0 (or higher) is installed on the PC and it can communicate with the Freedom board KL25Z, as described in the kit's documentation. (See [Section 5.1, Installing SPIGen Freeware On Your Computer, page 14](#)).
2. Connect the KL25Z to the PC using the USB KL25Z port (left side of SW1). The USB_PWR LED on the KITPT2000FRDM3C should be illuminated.
3. Attach the +12 VDC supply (do not turn on power yet) to the V_{SUPP} input connector on the KITPT2000FRDM3C, making sure to observe the GND and +12 V terminals. The current capability of the +12 V supply should exceed the maximum total current the number of simultaneous ON loads requires.
4. Attach loads (Injectors) to the INJ1, INJ2, and INJ3 output terminals as desired.
5. Turn on the +12 V supply. Verify all is working correctly by observing the +5.0 V LED, which should be illuminated.

5.4 Running an Example Program

1. Launch the SPIGen program.
2. When the KL25Z is properly connected to the computer. The LED on the KL25Z turns blue while the SPIGen is running.
3. Load the config file, by clicking on “File” then “Open” and browse to the KITPT2000SW.spi file located inside the “Injector Demo Files” directory.
4. Go to the “Micro code” page under “MC33PT2000”.
5. Set the RESETB pin high.
6. Click on “Load Filenames”.
7. Open the SPIGenMC33PT2000Files.txt included in the project example. All cells should be filled with the right path (Code Ramx, Data Ramx, Channelx, Main, IO, Diagnostics Configuration Registers).
8. Click on the “Download All” button to download all micro-code (CRAM), data ram, and register values into the PT2000 by the SPI.
9. Click the “Enable Flash on CH1 and CH2” button to run the code. At this point both channels should be operational.
10. Set the DRVEN high.
11. Set the Start Pulse Width (ms) duration.

5.5 Running the Example Batch Files

1. Go to the “Batch commands” page and select the batch file desired to run. There are five choices. “Start1” through “Start3” pulse only one injector (1, 2, or 3). The “Start1-3” batch command pulses all three injectors in sequence.
2. Click on the “Send Continuously” button.
3. Observe the three loads attached to the KITPT2000FRDM3C are turning on and off in succession.

There are other demo batch examples which can be run and examined to learn how to use the KITPT2000FRDM3C.

5.6 Typical Peak and Hold scope Image

A scope image example is shown with an injector connected to INJ1. The expected behavior is when the Start1 pin rise injection goes into Boost phase until the boost current is reached. It jumps to peak phase for 10 μ s, then bypass phase for 10 μ s, and then hold phase until the start pin goes low.

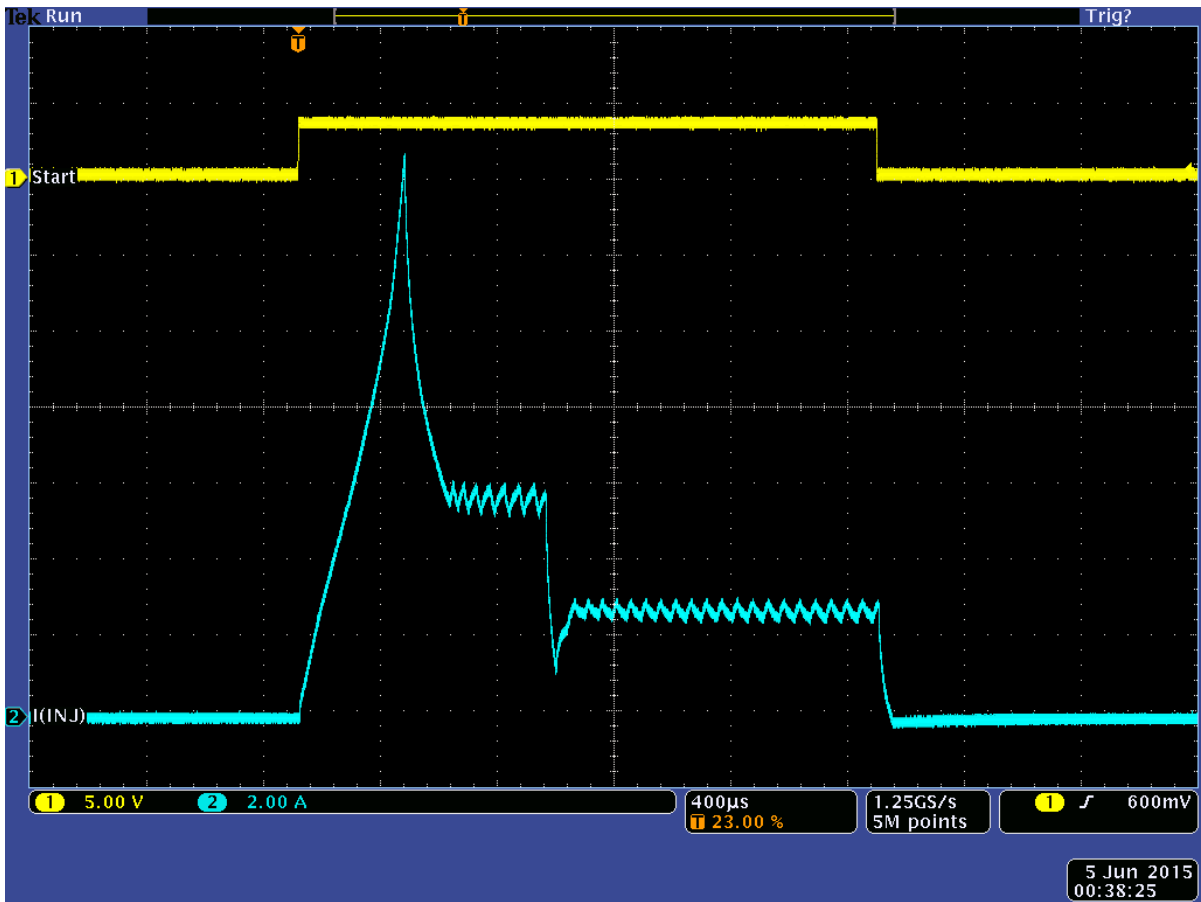
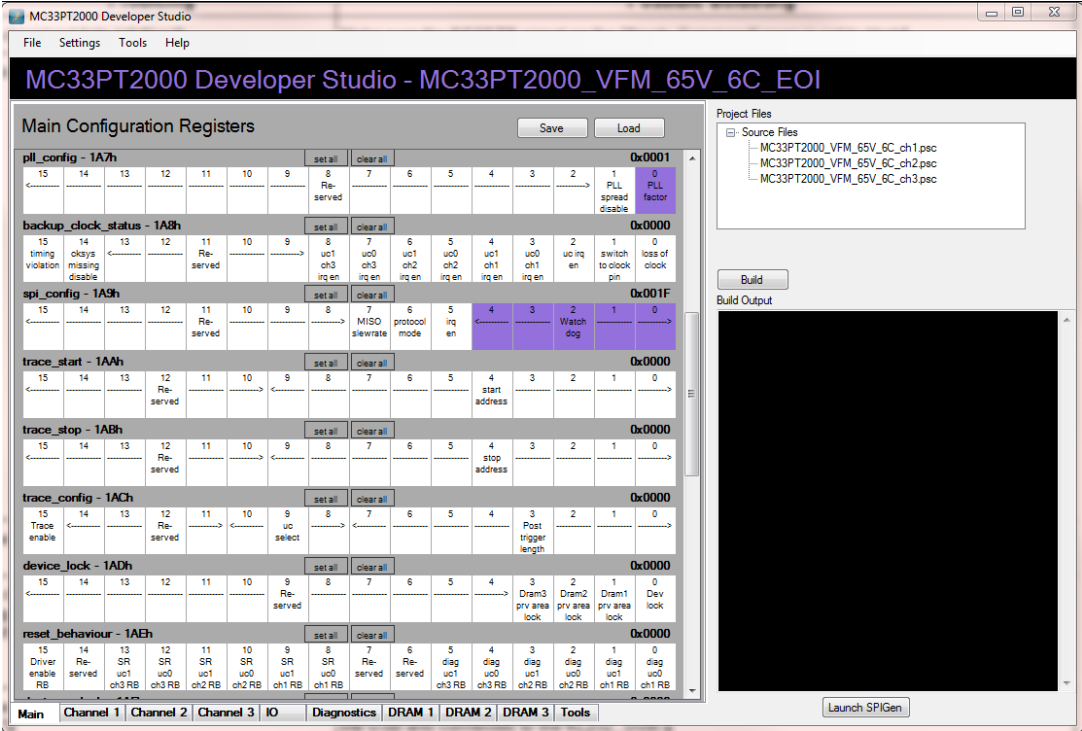

Figure 9. Peak and Hold Scope Image

6 Troubleshooting

Table 8. Troubleshooting

Problem	Possible Solution
Code download fails (all files)	Make sure the RESETB signal on the “Single Command” page is set to High
Download fails after “Main Configuration Register”	<p>Watchdog timeout is set too low. Using the IDE, update the spi_config register in the main config reg so the watchdog value is set to the maximum value (bits 0-4 are set)</p>  <p>The screenshot shows the MC33PT2000 Developer Studio interface. The 'Main Configuration Registers' window is open, displaying several registers. The 'spi_config - 1A9h' register is selected, showing a value of 0x001F. Bit 4, labeled 'Watchdog', is set to 1. Other bits are set to 0. The interface includes 'set all' and 'clear all' buttons for each register, and a 'Launch SPIGen' button at the bottom right.</p>
Code downloaded successfully, but outputs are not toggling, and the V _{BOOST} voltage is not correct	<p>Make sure the DRVEN signal on the “Single Command” or “Microcode” page is set to High</p> <p>OR</p> <p>After clicking on Download All, make sure to click on Enable Flash on CH1 and CH2</p> <p>OR</p> <p>Make sure that power supply current limitation is sufficiently high (~4 A)</p>
SPIGen error: “The USB to SPI Device was not found”	Make sure to use at least SPIGEN Rev 7.0. The KL25Z must be connected to the computer using the USB and connected to the KL25Z_USB.

7 Schematics

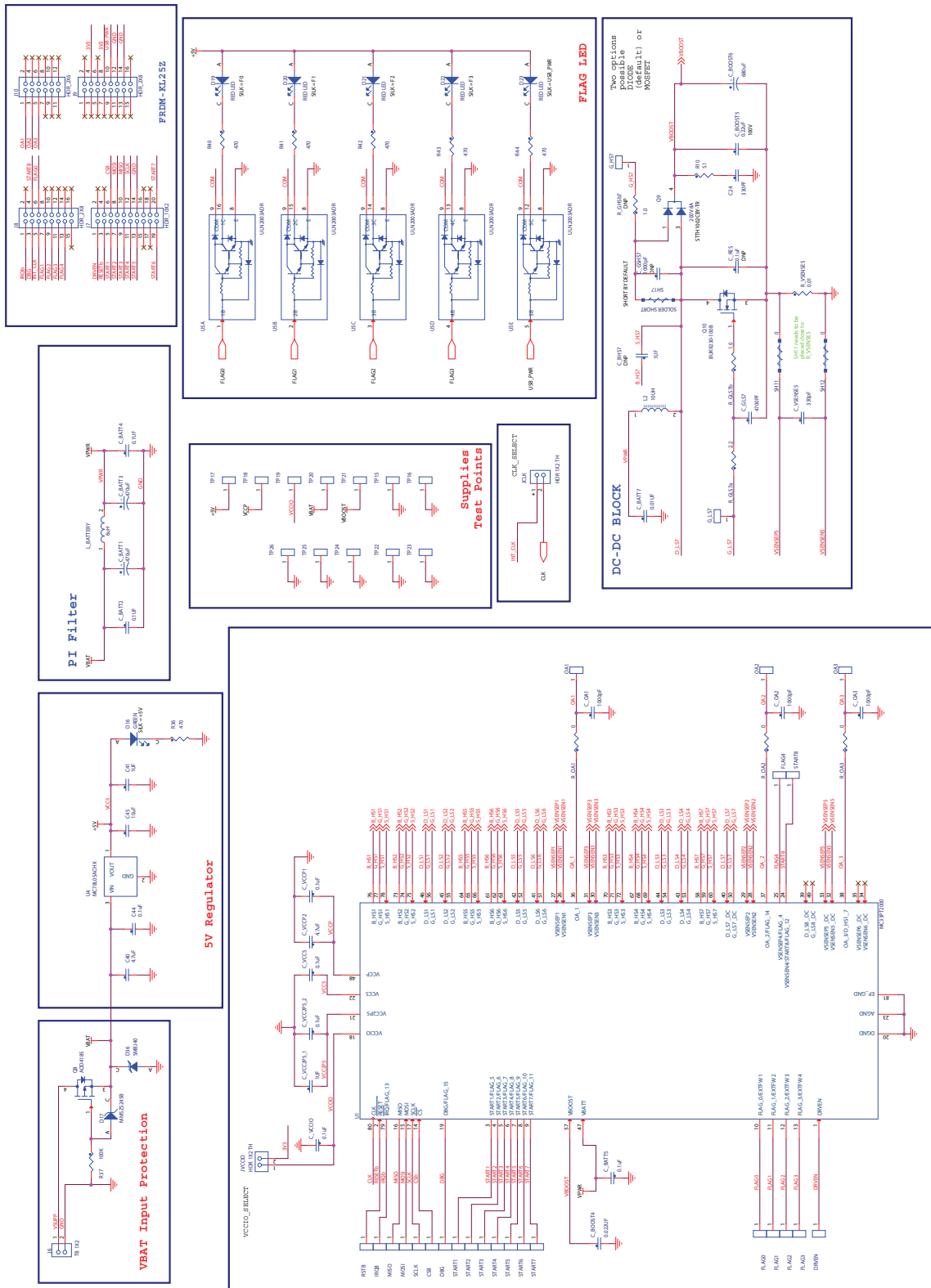
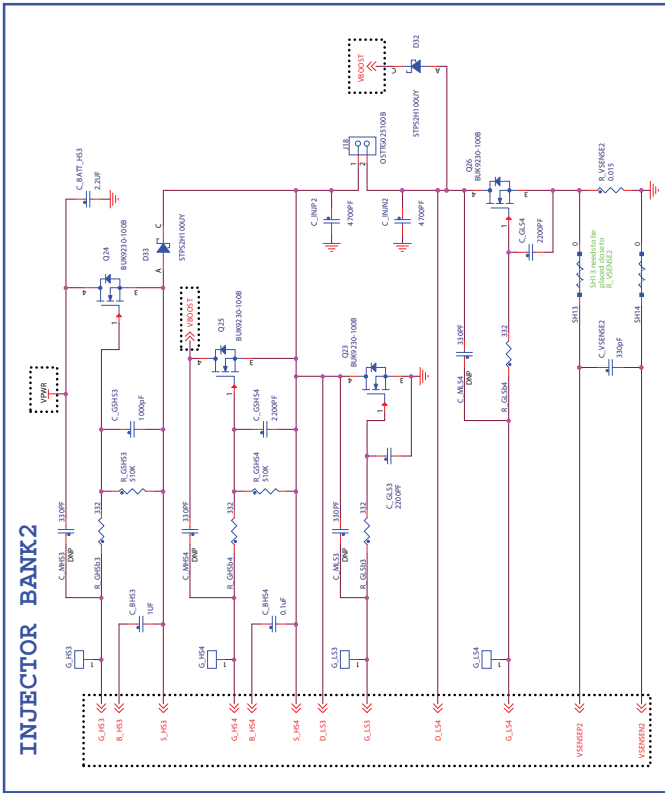

Figure 10. KITPT2000FRDM3C Evaluation Board Schematic Part 1



BANK1		BANK2	
HS_Vboost	2	HS_Vboost	4
HS_Vbat	1	HS_Vbat	3
LS_FW	1	LS_FW	3
LS	2	LS	4
Sense	1	Sense	2

BANK3		DCDC	
HS_Vboost	6	HS_FW	7
HS_Vbat	5	LS	7
LS_FW	5	DIODE	No
LS	6	Sense	5

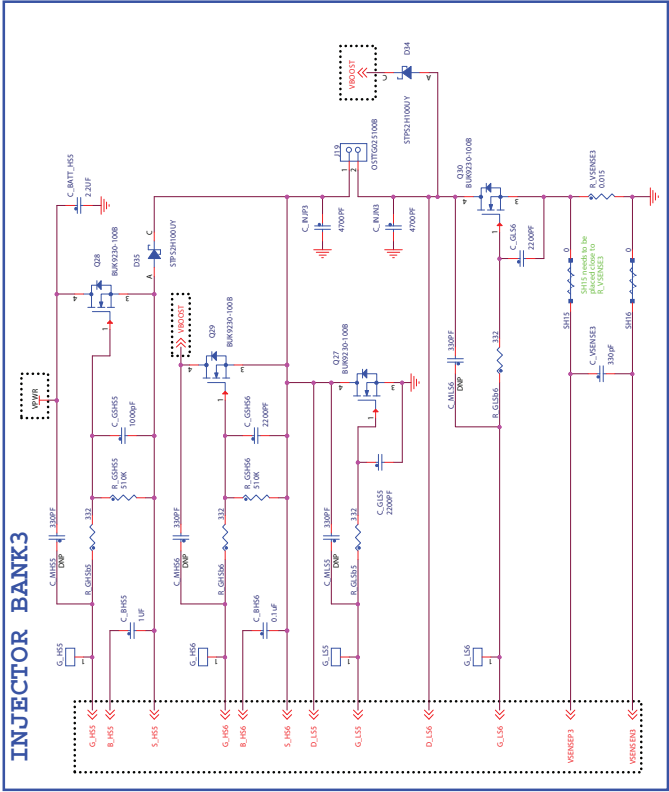
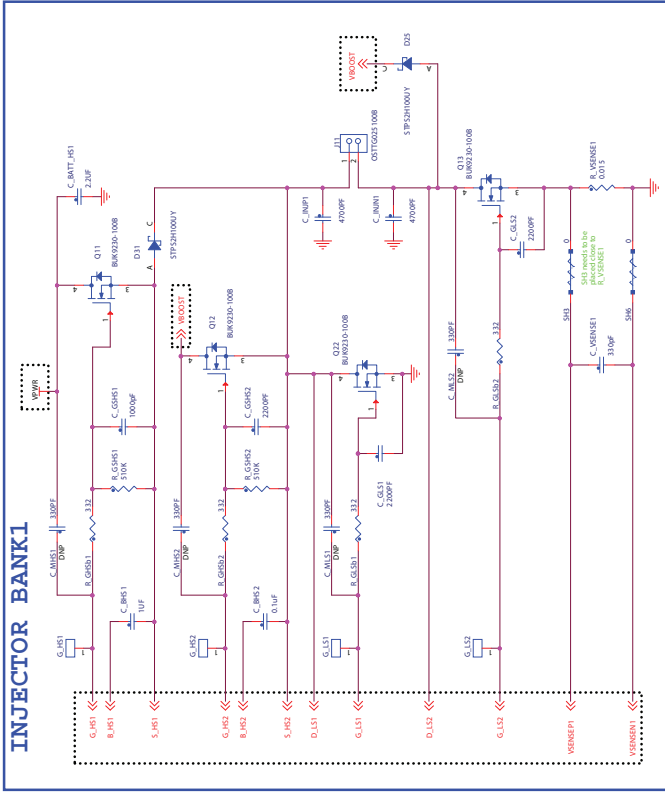

Figure 11. KITPT2000FRDM3C Evaluation Board Schematic Part 2

8 Silkscreen

8.1 Silkscreen Top

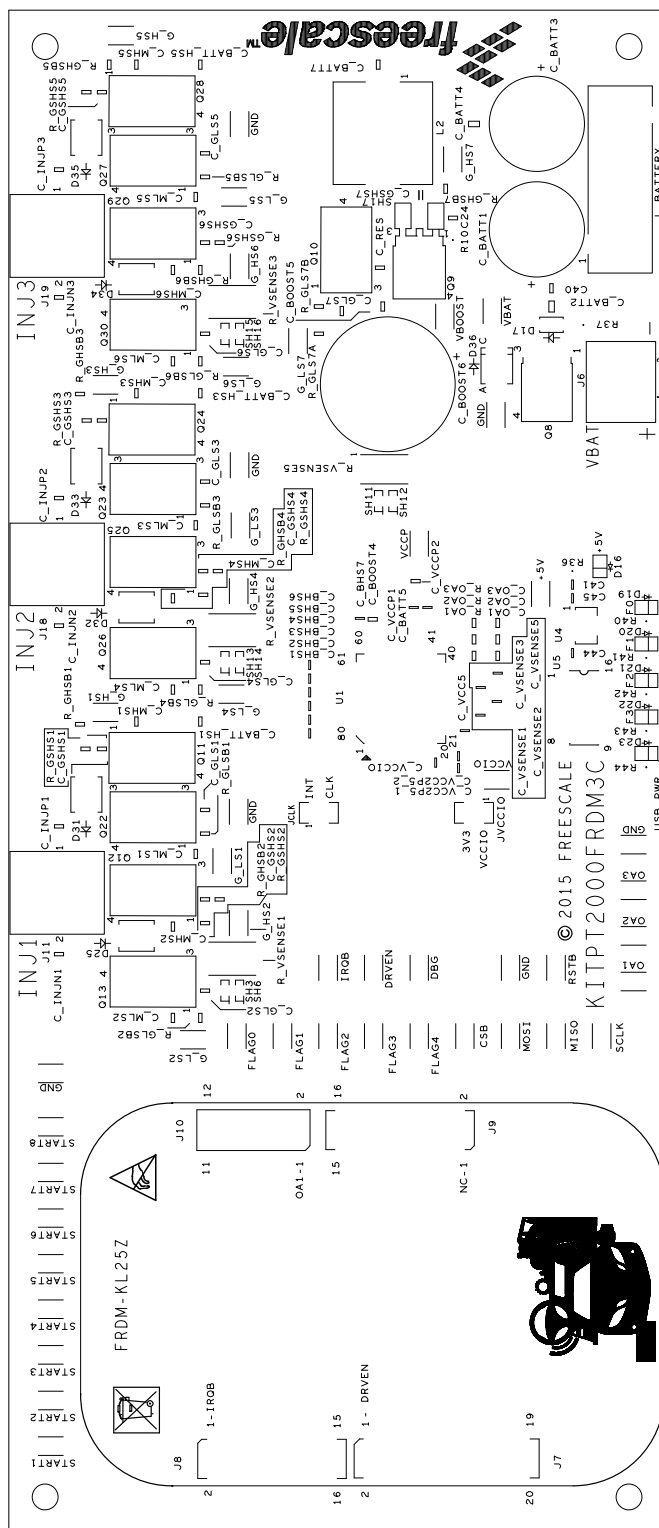

Figure 12. KITPT2000FRDM3C Silkscreen Top Layer

9 Bill of Materials

Table 9. Bill of Materials (2)

Item	Qty.	Schematic Label	Value	Description	Part Number	Assy. Opt.
Freescale Components						
1	1	U1		IC DRV 1.0 MHZ Auto 5.0 - 36 V LQFP80	MC33PT2000AC	(4)
Active Components						
2	1	U4	MC78L05AC HX	IC VREG 5.0 V 100 MA 30 V SOT-89		
3	1	U5	ULN2003ADR	IC Tran Array NPN DARL Seven 50 V 0.5 A SOIC16		
4	1	L2	10 μ H	IND PWR 10 μ H at 100 KHZ 16 A 20% SMT		
5	1	L_BATTERY	6.0 uH	Ind Rod Chk 6.0 μ H at 10 KHZ 10 A 25% TH		
6	1	Q8	AOD4185	Tran PMOS PWR 40 A 40 V TO252		
7	13	Q10, Q11, Q12, Q13, Q22, Q23, Q24, Q25, Q26, Q27, Q28, Q29, Q30	BUK9230-100 B	Tran NMOS PWR SW 47 A 100 V DPAK		
Diodes						
8	1	D16	Green	LED GRN SGL 30 MA SMT 0805		
9	1	D17	MMSZ5245B	Diode ZNR -- 15 V 0.5 W SOD123		
10	5	D19, D20, D21, D22, D23	Red Led	LED Red SGL 30 MA SMT 0805		
11	6	D25, D31, D32, D33, D34, D35	STPS2H100U Y	Diode SCH RECT 2.0 A 100 V AEC-Q101 SMB		
12	1	D36	SMBJ40	Diode TVS 9.3 A 40 V SMB SMT		
13	1	Q9	200 V 8.0 A	Diode Array GP 200 V 8.0 A AEC-Q101 DPAK		
Capacitors						
14	13	C24, C_MHS1, C_MHS2, C_MHS3, C_MHS4, C_MHS5, C_MHS6, C_MLS1, C_MLS2, C_MLS3, C_MLS4, C_MLS5, C_MLS6	330 pF	Cap Cer 330 pF 100 V 5% C0G 0805		
15	2	C40, C_VCCP2	4.7 μ F	Cap Cer 4.7 μ F 50 V 20% X5R 0805		
16	6	C41, C_BHS1, C_BHS3, C_BHS5, C_BHS7, C_VCC2P5_1	1.0 μ F	Cap Cer 1.0 μ F 25 V 10% X7R AEC-Q200 0603		
17	9	C44, C_BATT5, C_BHS2, C_BHS4, C_BHS6, C_VCC2P5_2, C_VCC5, C_VCCIO, C_VCCP1	0.1 μ F	Cap Cer 0.1 μ F 50 V 10% X7R AEC-Q200 0603		
18	1	C45	10 μ F	Cap Cer 10 μ F 10 V 20% X5R 0603		
19	2	C_BATT1, C_BATT3	470 μ F	Cap Alel 470 μ F 35 V 20% -- RADIAL		
20	2	C_BATT2, C_BATT4	0.1 μ F	Cap Cer 0.1 μ F 200 V 10% X7R 1206		
21	1	C_BATT7	0.01 μ F	Cap Cer 0.01 μ F 100 V 10% X7R 0805		
22	3	C_BATT_HS1, C_BATT_HS3, C_BATT_HS5	2.2 μ F	Cap Cer 2.2 μ F 25 V 10% X7R 0805		
23	1	C_BOOST4	0.022 μ F	Cap Cer 0.022 μ F 50 V 10% X7R 0805		

Table 9. Bill of Materials ⁽²⁾ (continued)

Item	Qty.	Schematic Label	Value	Description	Part Number	Assy. Opt.
24	1	C_BOOST5	0.22 μ F	Cap Cer 0.22 μ F 100 V 20% X7S 0805		
25	1	C_BOOST6	680 μ F	Cap Alel 680 μ F 100 V 20% -- RADIAL		
26	9	C_GLS1, C_GLS2, C_GLS3, C_GLS4, C_GLS5, C_GLS6, C_GSHS2, C_GSHS4, C_GSHS6	2200 pF	Cap Cer 2200 pF 25 V 20% X7R 0805		
27	7	C_GLS7, C_INJN1, C_INJN2, C_INJN3, C_INJP1, C_INJP2, C_INJP3	4700 pF	Cap Cer 4700 pF 100 V 10% X7R 0805		
28	7	C_GSHS1, C_GSHS3, C_GSHS5, C_GSHS7, C_OA1, C_OA2, C_OA3	1000 pF	Cap Cer 1000 pF 50 V 10% X7R 0805		
29	1	C_RES	0.1 μ F	Cap Cer 0.1 μ F 100 V 10% X7R AEC-Q200 0805		
30	4	C_VSENSE1, C_VSENSE2, C_VSENSE3, C_VSENSE5	330 pF	Cap Cer 330 pF 25 V 10% X7R 0603		

Resistors

31	1	R10	5.1	Res MF 5.1 Ω 1/10 W 5% 0603		
32	6	R36, R40, R41, R42, R43, R44	470	Res MF 470 Ω 1/10 W 5% 0603		
33	1	R37	100 k	Res MF 100 k 1/10 W 5% 0603		
34	12	R_GHSB1, R_GHSB2, R_GHSB3, R_GHSB4, R_GHSB5, R_GHSB6, R_GLSB1, R_GLSB2, R_GLSB3, R_GLSB4, R_GLSB5, R_GLSB6	332	Res MF 332 Ω 1/8 W 1% 0805		
35	2	R_GHSB7, R_GLS7B	1.0	Res MF 1.0 Ω 1/8 W 1% 0805		
36	1	R_GLS7A	2.2	Res MF 2.20 Ω 1/8 W 1% 0805		
37	6	R_GSHS1, R_GSHS2, R_GSHS3, R_GSHS4, R_GSHS5, R_GSHS6	510 k	Res MF 510 k 1/8 W 5% 0805		
38	3	R_OA1, R_OA2, R_OA3	0	Res MF Zero 1/8 W AEC-Q200 0805		
39	3	R_VSENSE1, R_VSENSE2, R_VSENSE3	0.015	Res MF 0.015 Ω 2.0 W 1% 2512		
48	1	R_VSENSE5	0.01	Res MF 0.01 Ω 1.0 W 1% 2512		
41	8	SH3, SH6, SH11, SH12, SH13, SH14, SH15, SH16	0	Zero Ω Cut Trace 0603 PADS; No Part to Order		
42	1	SH17	Solder Short	Solder Short 0805 SMT No Part to Order		

Switches, Connectors, Jumpers and Test Points

43	1	J6	TB 1X2	Con 1X2 TB TH 5.0 mm 12.9MM SN 150L		
44	1	J7	HDR_10X2	HDR 2X10 TH 100 mil CTR 330H AU 100L		
45	2	J8, J9	HDR_2X8	HDR 2X8 TH 100 mil CTR 330H AU		
46	1	J10	HDR_2X6	HDR 2X6 TH 100 mil CTR 330H AU		
47	3	J11, J18, J19	OSTTG02510 0B	CON 1X2 TB TH 5.08 mm 504H -- 177L		
48	2	JCLK, JVCIO	HDR 1X2 TH	HDR 1X2 TH 100 mil SP 339H AU 98L		

Table 9. Bill of Materials (2) (continued)

Item	Qty.	Schematic Label	Value	Description	Part Number	Assy. Opt.
49	50	CSB, DBG, DRVEN, FLAG0, FLAG1, FLAG2, FLAG3, FLAG4, G_HS1, G_HS2, G_HS3, G_HS4, G_HS5, G_HS6, G_HS7, G_LS1, G_LS2, G_LS3, G_LS4, G_LS5, G_LS6, G_LS7, IRQB, MISO, M0SI, OA1, OA2, OA3, RSTB, SCLK, START1, START2, START3, START4, START5, START6, START7, START8, TP15, TP16, TP17, TP18, TP19, TP20, TP21, TP22, TP23, TP24, TP25, TP26	3.65x2.05 mm	Test Point 3.65x2.05 mm SMT		

Notes

2. Freescale does not assume liability, endorse, or warrant components from external manufacturers are referenced in circuit drawings or tables. While Freescale offers component recommendations in this configuration, it is the customer's responsibility to validate their application.
3. Do not populate
4. **Critical components.** For critical components, it is vital to use the manufacturer listed.

10 References

The following URLs are where you can obtain information on related Freescale products and application solutions:

Freescale.com Support Pages	Description	URL
KITPT2000FRDM3C	Tool Summary Page	http://www.freescale.com/webapp/sps/site/prod_summary.jsp?code=KITPT2000FRDM3C
KITPT2000FRDM6C	Tool Summary Page	http://www.freescale.com/webapp/sps/site/prod_summary.jsp?code=KITPT2000FRDM6C
PT2000-IDEUG	Developer Studio User's Guide	http://www.freescale.com/files/analog/doc/user_guide/PT2000-IDEUG.pdf
PT2000	Product Summary Page	http://www.freescale.com/webapp/sps/site/prod_summary.jsp?code=PT2000
FRDM-KL25Z	Tool Summary Page	http://www.freescale.com/webapp/sps/site/prod_summary.jsp?code=FRDM-KL25Z
SPIGen	Tool Summary Page	http://www.freescale.com/webapp/sps/site/prod_summary.jsp?&code=SPIGEN
Analog Home Page		http://www.freescale.com/analog
Automotive Home Page		http://www.freescale.com/automotive

10.1 Support

Visit www.freescale.com/support for a list of phone numbers within your region.

10.2 Warranty

Visit www.freescale.com/warranty for a list of phone numbers within your region.

11 Revision History

Revision	Date	Description
1.0	3/2015	<ul style="list-style-type: none">Initial release
2.0	6/2015	<ul style="list-style-type: none">Added instruction to Section 5.4, Running an Example Program, page 16Updated Figure 9