

Automotive Load Switch with OVP and RB Protection

Features

- Wide input operating range from 6V to +40V DC Input
- Low resistance MOSFET Switch typ. 41mΩ
- Reverse Battery Protection to -28V
- Fixed over-voltage protection
 - Fixed: 27V ± 0.8V or 20.3V ± 0.8V
- Fast OVP response time typ. 360ns
- Continuous output current up to 6A
- Over-temperature Protection with Auto-Retry
- Open drain fault flag
- Shutdown pin with low shutdown current
- Battery detection output
- Input ESD protection to IEC61000-4-2 (Level 4)
 - Contact: ±8kV
 - Air: ±15kV
 - Other pins HBM: ±2kV to AEC Q100-002
- AEC-Q100 Qualified
- Meets automotive ISO7637 transient requirements with suitable external TVS diodes
- Pb-free TDFN44-12 package
- -40°C to +125°C operating temperature range

Applications

- Automotive Load Switching
- Reverse Power Supply Protection
- Telecom/Server/Networking System
- Industrial and Medical Systems
- Portable Instrumentation

Brief Description

The KTS1640Q and KTS1641Q are low-resistance, electronically controlled load switches, with enhanced protection features, used to protect loads from abnormal power supply or load problems. Operating from a wide input supply voltage of between 6V and 40V, the KTS1640Q and KTS1641Q protect the system from reverse input supplies down to -28V.

Integrating two N-Channel MOSFETs, the device includes fixed over-voltage protection of 27V (KTS1640Q) or 20.3V (KTS1641Q) along with over-temperature protection with auto-retry. Following an over-voltage condition only, KTS1640Q and KTS1641Q will automatically resume operation, when the over-voltage condition is removed.

An ENABLE pin allows the MOSFET switch to be enabled or disabled, placing the device in a low current shutdown mode. System monitoring is provided by a fault FLAG.

To inform the system that the battery or power supply is connected, BDET mirrors the input voltage less the drop across the reverse battery protection MOSFET and sources up to a maximum of 500mA

Further protection includes over-temperature shutdown and the input pin is fully ESD protected to comply with the IEC61000-4-2 (Level 4) specification.

The KTS1640Q and KTS1641Q are packaged in an advanced, fully green compliant, TDFN44-12 package.

Typical Application

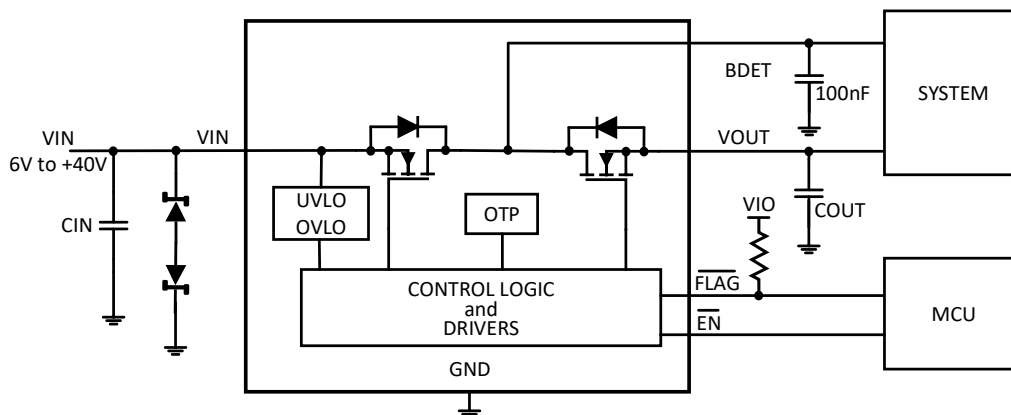

Ordering Information

Part Number	Marking ¹	OVP	Fault Response	Ambient Operating Temperature	Package
KTS1640QGDV-TR	MRYWZ	27V	Auto Retry	-40°C to +125°C	TDFN44-12
KTS1641QGDV-TR	MZYWZ	20.3V	Auto Retry	-40°C to +125°C	TDFN44-12

1. "XXYWZ" is the device code, date code and assembly code.

Kinetic Technologies cannot assume responsibility for use of any circuitry other than circuitry entirely embodied in a Kinetic Technologies product. No intellectual property or circuit patent licenses are implied. Kinetic Technologies reserves the right to change the circuitry and specifications without notice at any time.