

## Surge and Over-voltage Protected Load Switch

### Features

- Surge and ESD protected Input
  - Surge Protection
    - IEC 61000-4-5: > 100V
  - ESD Protection
    - IEC 61000-4-2 (Level 4)
      - Contact: ±8kV
      - Air Gap: ±15kV
    - Human Body Model: ±2kV
- Wide Input voltage range
  - 2.5V to 28V
- Low Quiescent Current: 60µA (typ.)
- N channel MOSFET load switch with low forward voltage drop
  - 72mV @ 2A
- Fast turn-off response time
  - 300ns
- Flexible trip-point options
  - Fixed 6.8V
  - Adj. 4V to 20V
- Auto-enabled switch with typ. 15ms debounce time
- Additional Under voltage (UVLO), Short-circuit and Thermal shutdown protection
- Open-drain power good output
- Pb-free WLCSP-12 package
- -40°C to +85°C Temperature Range

### Brief Description

The KTS1680 over-voltage protection device features an ultra-low 38mΩ (typical) on-resistance high current integrated MOSFET which actively protects low-voltage systems from voltage supply faults up to +28V<sub>DC</sub>. An internal clamp protects the device from surges up to 100V.

An input voltage exceeding the over-voltage threshold will cause the internal MOSFET to turn off, preventing excessive voltage from damaging downstream devices. When the OVLO input set below the external OVLO select voltage, the KTS1680 automatically chooses the internal fixed OVLO threshold, preset to 6.8V (typical). The over-voltage protection threshold can be adjusted with optional resistor divider to a voltage between 4V and 20V.

The device features an open-drain output  $\overline{ACOK}$  indicating a stable supply between the minimum supply voltage and OVLO threshold. The KTS1680 is also protected against over-current faults and has thermal protection.

The KTS1680 is available in a RoHS and Green compliant 12-Bump 1.30mm x 1.96mm WLCSP.

### Applications

- Smartphones
- Tablet Computers
- Mobile Internet Devices
- Peripherals

### Typical Application

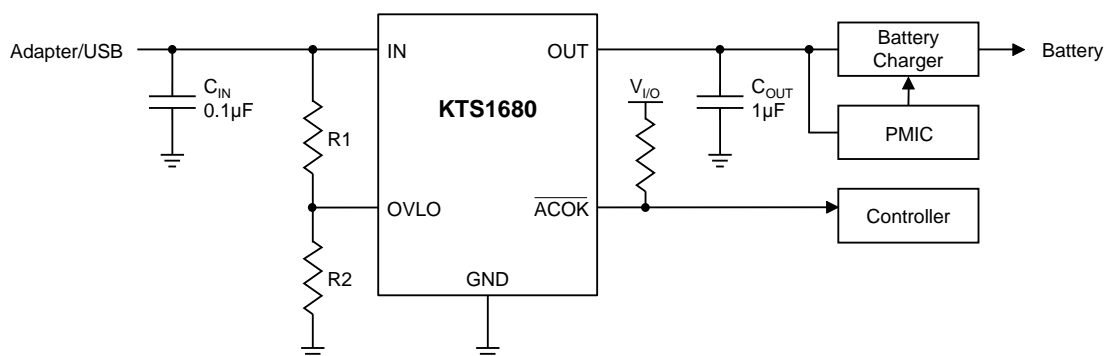

**Pin Descriptions**

Name	Function
GND	Ground.
OUT	Output voltage
$\overline{ACOK}$	Open-drain power good output. $\overline{ACOK}$ is driven low during normal operation and becomes high impedance when an out-of-range condition is detected. Connect a pull-up resistor between the logic pin and the system rail.
IN	Voltage input. Bypass IN with 0.1 $\mu$ F capacitor as close as possible to the device.
OVLO	External OVLO adjustment. Connect OVLO to GND when using the internal fixed threshold. Connect a resistor-divider to OVLO to set the adjustable OVLO threshold.

**WLCSP-12, 1.30 x 1.96mm**

TOP VIEW

TOP VIEW

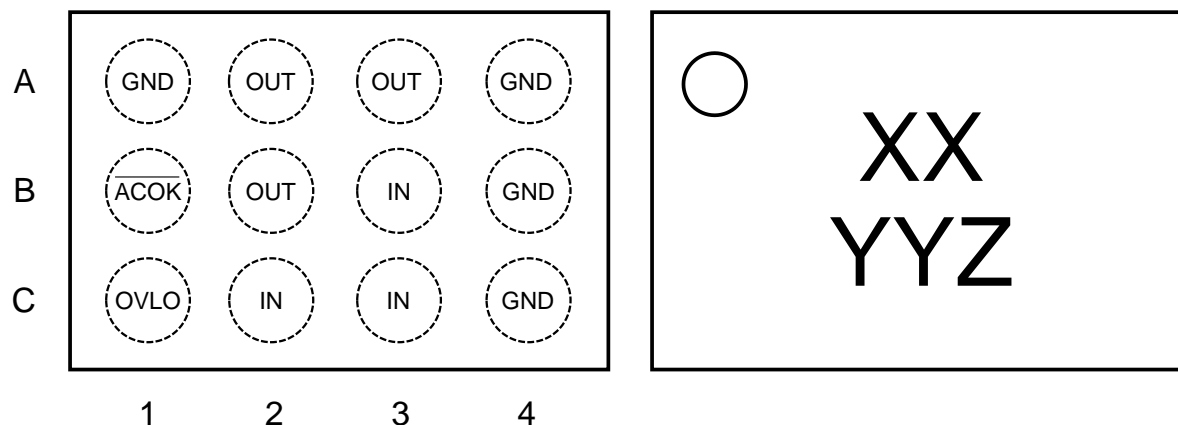

12-Bump 1.30mm x 1.96mm x 0.62mm  
WLCSP Package  
XX = Device Code (Top Mark)  
YYZ (Date Code and Assembly Code)

## Absolute Maximum Ratings<sup>1</sup>

(T<sub>A</sub> = 25°C unless otherwise noted)

Symbol	Description	Value	Units
IN <sup>2</sup>	Input Voltage	-0.3 to 29	V
OUT	Output Voltage	-0.3 to VIN+0.3	V
OVLO	OVLO Pin	-0.3 to 7	V
ACOK	ACOK Pin	-0.3 to 6	V
IN, OUT Current	Continuous Current	4.5	A
	Peak Current (10msec)	8	A
T <sub>J</sub>	Operating Temperature Range	-40 to 150	°C
T <sub>s</sub>	Storage Temperature Range	-65 to 150	°C
T <sub>LEAD</sub>	Maximum Soldering Temperature (at leads, 10 sec)	260	°C

## Thermal Capabilities

Symbol	Description	Value	Units
θ <sub>JA</sub>	Thermal Resistance – Junction to Ambient <sup>3</sup>	73	°C/W
P <sub>D</sub>	Maximum Power Dissipation at T <sub>A</sub> ≤ 25°C	1.28	W
ΔP <sub>D</sub> /ΔT	Derating Factor Above T <sub>A</sub> = 25°C	-12.8	mW/°C

## Recommended Operating Range

Description	Value
Input Voltage Range	2.7V to 28V
Output Load Capacitance Range	up to 100μF

## Ordering Information

Part Number	Marking <sup>4</sup>	Operating Temperature	Package
KTS1680EAB-TR	GFYYZ	-40°C to +85°C	WLCSP-12

- Stresses above those listed in Absolute Maximum Ratings may cause permanent damage to the device. Functional operation at conditions other than the operating conditions specified is not implied. Only one Absolute Maximum rating should be applied at any one time
- Survives burst pulses up to 100V with 2Ω series resistance.
- Junction to Ambient thermal resistance is highly dependent on PCB layout. Values are based on thermal properties of the device when soldered to an EV board.
- “YYZ” is the date code and assembly code.

## Electrical Characteristics<sup>5</sup>

$V_{IN} = +2.5V$  to  $+28V$  and  $C_{IN} = 0.1\mu F$ . Unless otherwise noted, the *Min* and *Max* specs are applied over the full operation temperature range of  $-40^{\circ}C$  to  $+85^{\circ}C$ , while *Typ* values are specified at room temperature ( $25^{\circ}C$ ).  $V_{IN} = 5V$ ,  $I_{IN} \leq 3A$ .

Symbol	Description	Conditions	Min	Typ	Max	Units
$V_{IN}$	Input operating range		2.5		28	V
$V_{IN\_CLAMP}$	Input clamp voltage	$I_{IN} = 10mA$ , $T_A = +25^{\circ}C$		32		V
$I_{IN}$	Input supply current	$V_{IN} = 5V$		70	120	$\mu A$
$I_{IN\_Q}$	OVLO supply current	$V_{OVLO} = 3V$ , $V_{IN} = 5V$ , $V_{OUT} = 0V$		63	120	$\mu A$
$V_{IN\_UVLO}$	Under voltage lockout threshold	$V_{IN}$ rising		1.9		V
$V_{UVLO\_HYST}$	Under voltage lockout hysteresis			0.1		V
$V_{IN\_OVLO}$	Internal over voltage trip level	$V_{IN}$ rising	6.6	6.8	7.0	V
		$V_{IN}$ falling	6.5			V
$V_{OVLO\_TH}$	OVLO External threshold		1.18	1.22	1.26	V
	Adjustable OVLO threshold range		4		20	V
$V_{OVLO\_SEL}$	External OVLO select threshold		0.2	0.25	0.3	V
$R_{DS(ON)}$	Switch On-Resistance	$V_{IN} = 5V$ , $I_{IN} = 1A$ , $T_A = +25^{\circ}C$		38	53	$m\Omega$
$I_{OVLO}$	OVLO input leakage current	$V_{OVLO} = V_{OVLO\_TH}$	-0.1		0.1	$\mu A$
<b>Digital Signals (<math>\overline{ACOK}</math>)</b>						
$V_{OL}$	$\overline{ACOK}$ output low voltage	$V_{I/O} = 3.3V$ , $I_{SINK} = 1mA$			0.4	V
$V_{ACOK\_LEAK}$	$\overline{ACOK}$ leakage current	$V_{I/O} = 3.3V$ , $\overline{ACOK}$ de-asserted	-1		1	$\mu A$
<b>ESD Protection</b>						
$V_{ESD}$	Human Body Model (HBM) Model = 2	All pins		$\pm 2$		kV
	IEC 61000-4-2 Contact discharge	IN pin		$\pm 8$		kV
	IEC 61000-4-2 Air gap discharge	IN pin		$\pm 15$		kV
<b>Thermal Shutdown</b>						
$T_{SHDN}$	Shutdown Temperature			130		$^{\circ}C$
	Shutdown Temperature Hysteresis			20		$^{\circ}C$

5. KTS1680 is guaranteed to meet performance specifications over the  $-40^{\circ}C$  to  $+85^{\circ}C$  operating temperature range by design, characterization and correlation with statistical process controls

## Timing Characteristics (Figure 1)

Symbol	Description	Conditions	Min	Typ	Max	Units
$t_{DEB}$	Debounce time	Time from $2.5V < V_{IN} < V_{IN\_OVLO}$ to $V_{OUT} = 10\%$ of $V_{IN}$		15		ms
$t_{SS}$	Soft-start time	$V_{OUT} = 10\%$ of $V_{IN}$ to soft-start off		15		ms
$t_{ON}$	Switch turn-on time	$V_{IN} = 5V$ , $R_L = 100\Omega$ , $C_{LOAD} = 100\mu F$ , $V_{OUT}$ from 10%, $V_{IN}$ to 90% $V_{IN}$		2		ms
$t_{OFF}$	Switch turn-off time	$V_{IN} > V_{OVLO}$ to $V_{OUT} = 80\%$ of $V_{IN}$ , $R_L = 100\Omega$ , $V_{IN}$ rising at $2V/\mu s$		0.3		$\mu s$

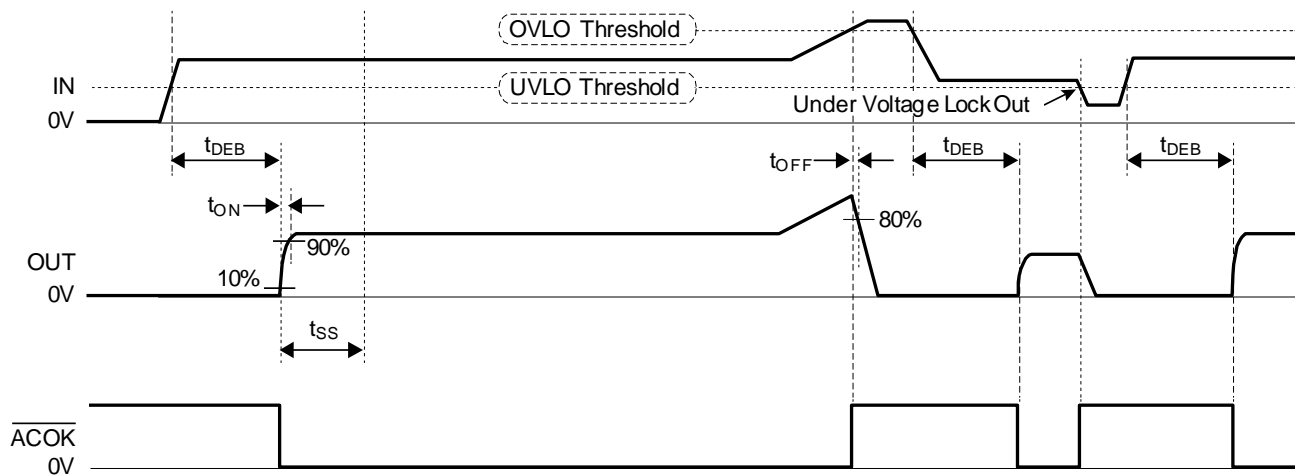
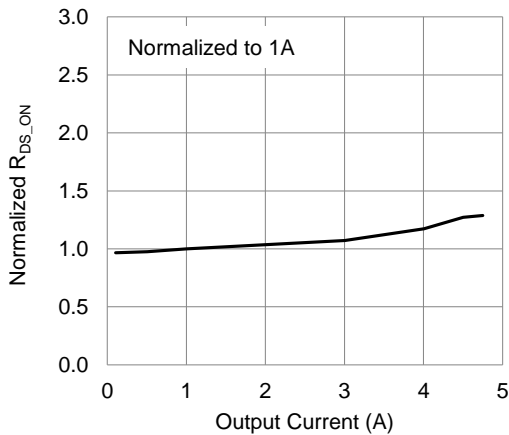

Figure 1. Timing Diagram

## Typical Characteristics

$V_{IN} = 5V$ ,  $C_{IN} = 0.1\mu F$ ,  $C_{OUT} = 1\mu F$ , OVLO pin = GND, Temp = 25°C unless otherwise specified.

Normalized  $R_{DS_{ON}}$  vs. Output Current



Normalized  $R_{DS_{ON}}$  vs. Temperature

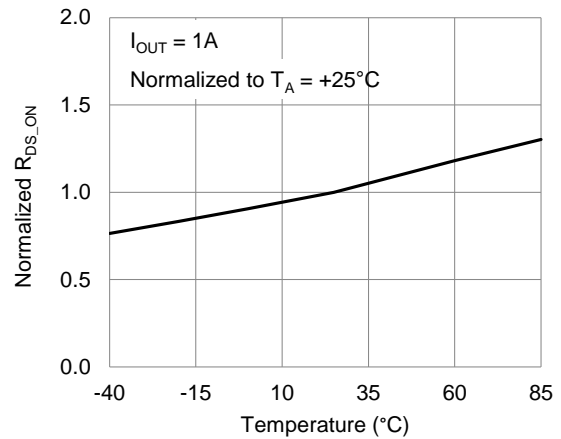

Input Supply Current vs. Input Voltage (no load)

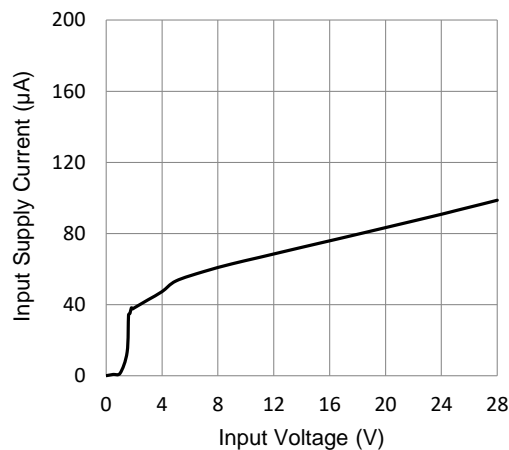

Normalized Debounce Time vs. Temperature

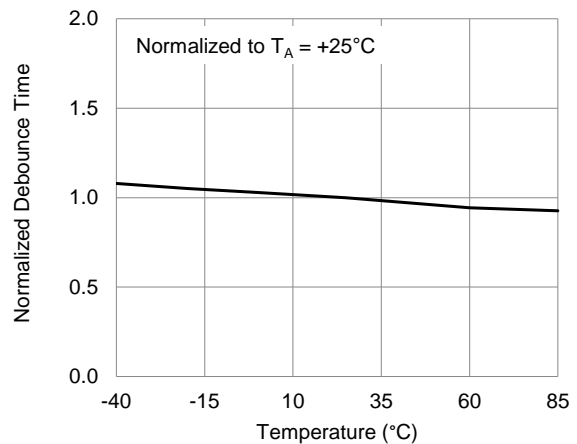

Normalized Fixed OVLO vs. Temperature (OVLO pin GND)

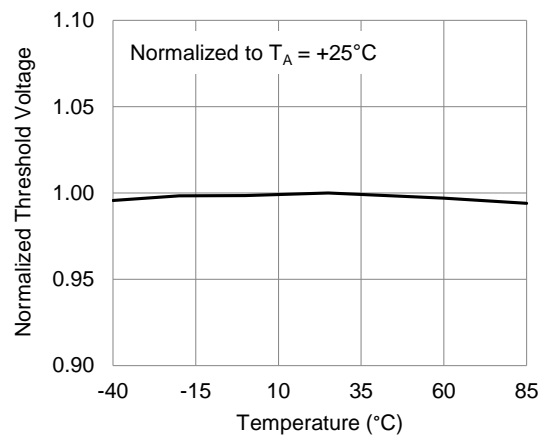

Normalized Adjustable OVLO Threshold vs. Temperature

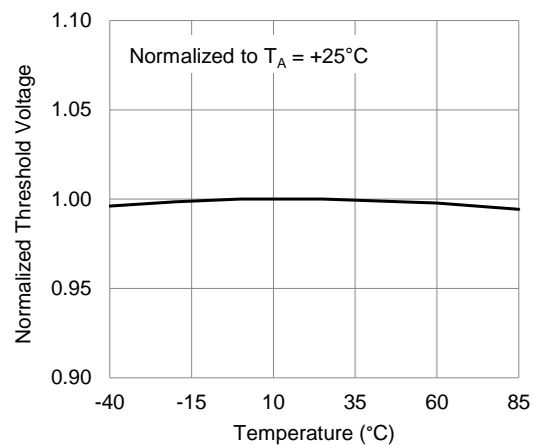

## Typical Characteristics (continued)

$V_{IN} = 5V$ ,  $C_{IN} = 0.1\mu F$ ,  $C_{OUT} = 1\mu F$ , OVLO pin = GND, Temp = 25°C unless otherwise specified.

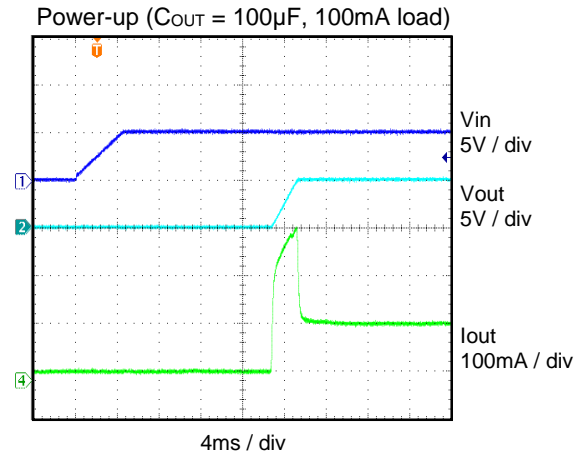
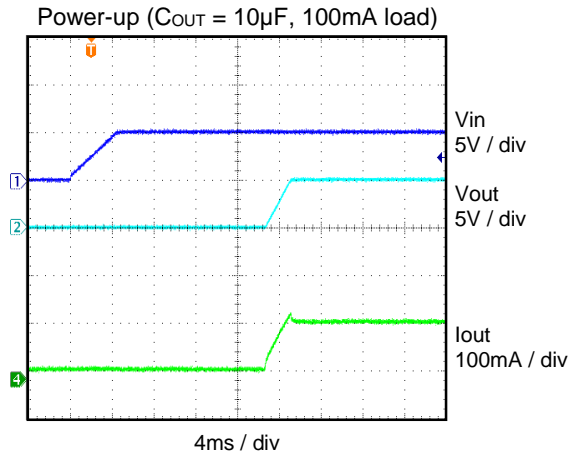

Over Voltage Fault Protection (VIN 5V to 8V step)

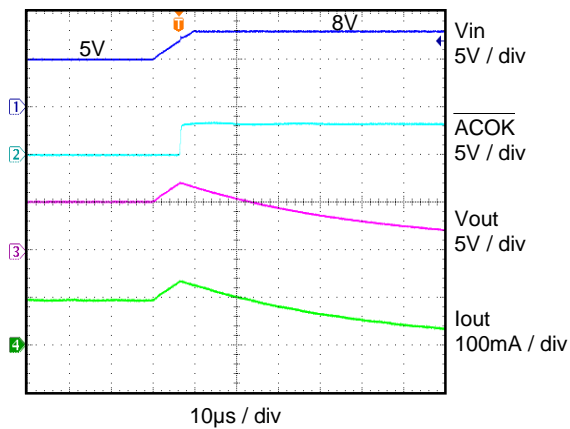

Short-Circuit Fault Protection (OUT short to GND)

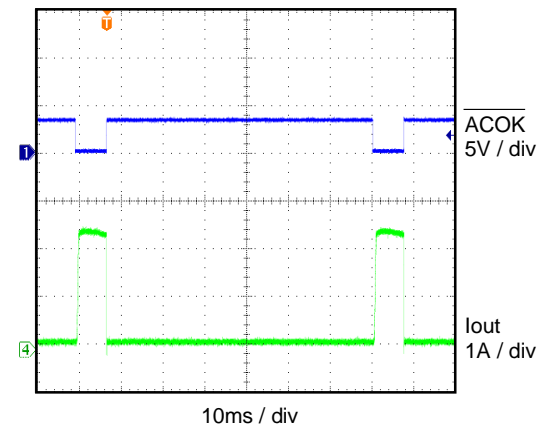

Surge Transient (110V)

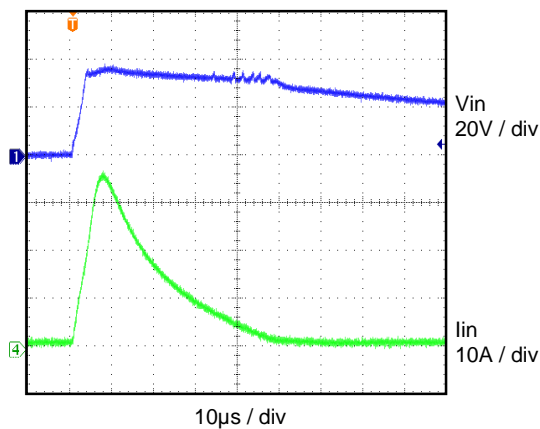

## Functional Block Diagram

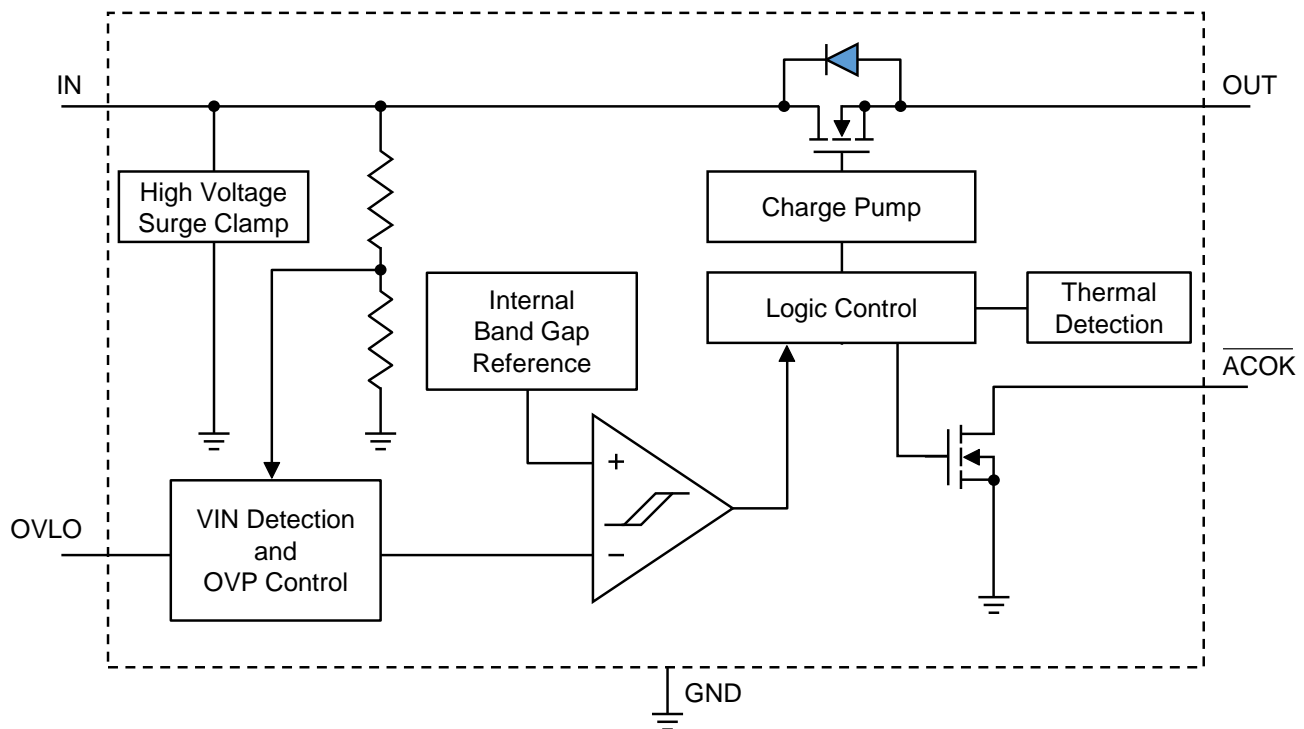

## Functional Description

The KTS1680 is inserted between the power supply or charger source and the load to be protected. The KTS1680 consists of a low resistance switch, under-voltage lockout protection (UVLO), over-voltage monitor and protection (OVLO) and an  $\overline{ACOK}$  output flag.

The KTS1680 switch device features a low on-resistance ( $R_{DS(ON)}$ ) internal N-Channel MOSFET and protects low-voltage systems against voltage faults up to +28VDC. An internal clamp also protects the device from input surge transients up to 100V. If the input IN pin voltage exceeds the overvoltage threshold, the internal FET is turned off to prevent damage to any downstream components connected to the output. A 15ms debounce time built into the device delays the internal FET turn on time.

The power good flag ( $\overline{ACOK}$ ) output pin can notify the system of the normal operation by pulling its output low. When an input power over-voltage or over-temperature occurs, the device releases the internal open-drain and the  $\overline{ACOK}$  output is set to logic high by the external pull-up resistor in order to alert the system.

### UVLO (Under Voltage Lockout)

The device has a built-in under voltage lock out (UVLO) circuit. During  $V_{IN}$  positive going slope, the output (OUT) remains disconnected from the input (IN) until  $V_{IN}$  voltage exceeds  $V_{IN\_UVLO}$  1.9V typical. This circuit has a 100mV hysteresis to provide noise immunity.



### OVLO (Over Voltage Lockout)

The KTS1680 can be configured for either an internal OVLO threshold, or an adjustable threshold when using the OVLO pin as a sense pin.

By connecting the OVLO pin to ground, the internal OVLO comparator uses the internally fixed OVLO value  $V_{IN\_OVLO}$  of 6.8V typical.

The adjustable threshold uses a 1.22V (typical) overvoltage trip threshold on the OVLO pin. With a resistor divider on the OVLO pin from IN to GND, the over-voltage protection point of IN can be adjusted between 4V and 20V. Once the OVLO pin voltage exceeds the OVLO select voltage,  $V_{OVLO\_SELECT}$  (0.25V typical), the comparator reads the OVLO pin voltage (a fraction of IN) set by the external resistor divider ( $R_1$ ,  $R_2$ ). A high resistance  $R_1$  value (around 1M $\Omega$ ) is ideal in order to minimize the current consumption. The resistor ratio  $R_1/R_2$  can be calculated from the following formula:

$$V_{INPUT\_OVLO\_THRESHOLD} = V_{OVLO\_TH} \times \left(1 + \frac{R_1}{R_2}\right) = 1.22V \times \left(1 + \frac{R_1}{R_2}\right)$$

### Internal MOSFET Switch

The KTS1680 incorporates an internal N-Channel MOSFET with ultra-low  $R_{DS}$  on-resistance of 38m $\Omega$  (typ). The MOSFET is internally driven by a charge pump that generates a necessary gate voltage above IN.

### ACOK Output

The  $\overline{ACOK}$  output is an active-low open-drain flag reporting good operation of the device. A pull-up resistor should be connected from the  $\overline{ACOK}$  pin to the system I/O rail. A fault is flagged when the output is being pulled high in the case of an over-voltage or over-temperature fault occurring.

### Thermal Protection

The internal FET turns off when the junction temperature exceeds +130 $^{\circ}$ C (typ). The device exits thermal shutdown after the junction temperature cools by 20 $^{\circ}$ C (typ) hysteresis.

### Input Capacitor

A 0.1 $\mu$ F or larger capacitor is typically recommended for CIN which should be located as close to the device IN pin as possible. For higher current operation, ceramic capacitors are recommended for CIN. During surge voltage transients, the internal input clamp keeps the input IN pin voltage below 40V, so 50V rated capacitors are ideal for most OVP applications.

### Output Capacitor

A small output capacitor COUT can be added to accommodate various load transient condition.

### USB On-The-GO (OTG) Operation

When used in an OTG application the KTS1680 can provide power from OUT to IN. Initially, the OTG voltage applied at OUT will forward bias the power switch bulk diode and present a voltage drop of approximately 0.7V between OUT and IN. The maximum current in this mode is limited by the thermal performance of the device and at an ambient temperature of 25 $^{\circ}$ C

$$I_{MAX} = \frac{1.28W}{0.7V} = 1.82A$$

This is purely a transitional condition as once the voltage at IN exceeds the UVLO voltage of 1.9V and the debounce time of 15ms has elapsed, the main power switch will turn fully ON, significantly reducing the voltage drop from OUT to IN.