

Ledex® Rotary Solenoids

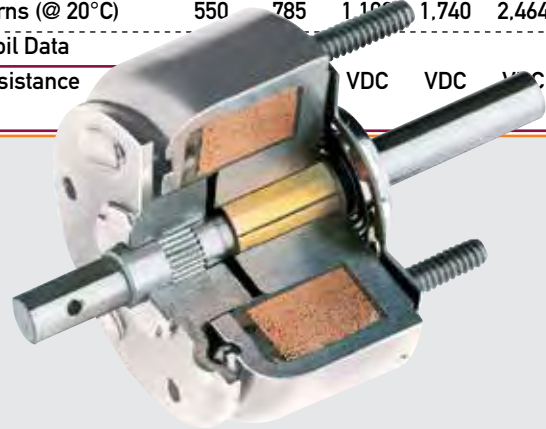

Maximum Duty Cycle	100%	50%	25%	10%	5%
Maximum ON Time (sec) when pulsed continuously ¹	∞	100	36	8	2.8
Maximum ON Time (sec) for single pulse ²	∞	162	44	9	3.2
Watts (@ 20°C)	10	20	40	100	200
Ampere Turns (@ 20°C)	550	785	1,100	1,740	2,464
Coil Data					
awg	Resistance		VDC	VDC	VDC



innovating motion

Ledex® Rotary Solenoids

ROTARY Solenoids



- The most extensive rotary solenoid line in the industry
- Extensive capabilities for modified, custom fabricated solenoids and solenoid-operated mechanisms
- Stock models available through distribution for next day shipment across North America
- Fast, two-week turnaround on prototypes, small orders or custom models
- Quantity orders for standard products delivered in 4-8 weeks

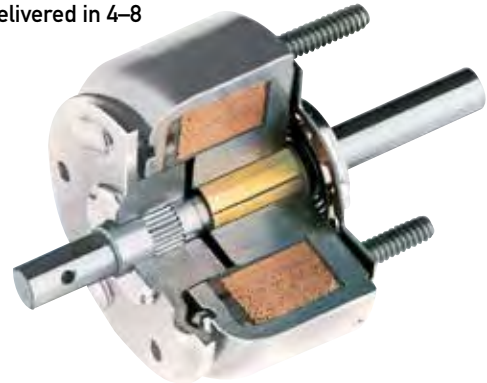

All catalog products manufactured after April 1, 2006 are RoHS Compliant

Bobbin Wound Coil Rotary Solenoids

- Manufactured by automated high-speed coil winding equipment for good performance and low cost
- Torque output up to 10 lb-in
- One million operations life rating (based on 25% duty cycle at 20°C ambient operating temperature)
- Standard strokes from 25°-110°; custom strokes available, some with one-time tooling charge
- Clockwise and counterclockwise rotation
- Wide variety of configurations to accommodate mounting and environmental considerations
- Many models available from distribution

Precision Standard Coil Rotary Solenoids

- Precision wound coil for excellent torque to size ratio
- Available in standard or long life versions
- Torque output up to 47 lb-in
- One million operations life rating for standard versions; 50 million operations or 100 million operation if lubricated every 10 million operations for long life versions (life ratings based on 25% duty cycle at 20°C ambient operating temperature)
- Three sizes from 1-7/8" to 2-3/4" diameters
- Standard strokes from 25°-110°; custom strokes available, some with one-time tooling charge
- Clockwise or counterclockwise rotation
- Wide variety of configurations to accommodate mounting and environmental considerations
- Hundreds of models available from distribution

Precision Elongated Coil Rotary Solenoids

- Built with 30% more coil copper than precision standard coil solenoids for lower power consumption
- Precision wound coil for excellent torque to size ratio
- Available in standard or long life versions
- Torque output up to 52 lb-in
- One million operations life rating for standard versions; 50 million operations or 100 million operations if lubricated every 10 million operations for long life versions (life ratings based on 25% duty cycle at 20°C ambient operating temperature)
- Four sizes from 1" to 1-9/16" diameters
- Standard strokes from 25°-110°; custom strokes available, some with one-time tooling charge
- Clockwise or counterclockwise rotation
- Wide variety of configurations to accommodate mounting and environmental considerations
- Many models available from distribution

Ledex® Rotary Solenoids

Modified and Custom-Designed Rotary Solenoids

Ledex offers comprehensive design and manufacturing resources to develop application specific rotary solenoids to meet your exact performance and unit cost objectives. Even though we offer thousands of standard rotary solenoid models, almost 80% of the product we build is specifically tailored to our customers' needs. So if you don't find exactly what you're looking for, please call us to discuss your requirements. Here are a few simple design options which we frequently encounter for rotary solenoid applications:

- Special shafts
- Mounting studs threaded to customer specification
- Slots, flats, or holes in shafts for machine linkage
- Double return springs for critical safety redundancy
- Armature covers

In-Stock Models for Next Day Shipment across North America

Many rotary solenoids are available from distribution inventory. If you're not sure of your exact requirement, you may consider using a stock model prototype as a quick and very inexpensive means to determine your exact requirements. Stock models are available in a variety of rotary strokes for most sizes of bobbin, precision standard and precision elongated coil styles.

Design Principles

Physical Characteristics

The rotary solenoid is a compact and rugged direct current electromagnet—almost solid steel and copper so as to give maximum power output with minimum size and weight. The coil is wound by a special precision winding process which puts the maximum amount of copper into the allowable space, thus resulting in each solenoid developing a tremendous torque for its size and power output. Heat-treated steel surrounds and protects the coil. The steel also provides a magnetic path of high permeability and low residual flux characteristics for efficient conversion of electrical energy to mechanical energy and fast response.

Determining Rotary Stroke

The three ball races which determine the rotary stroke are produced by a coining process. The coining of the solenoid case and armature plate determines the length and direction of the stroke and the value of starting torque. Refer to the selection charts for the standard strokes available. Special rotary strokes can be engineered for solenoids which are made to order.

Converting Linear to Rotary Motion

The rotary solenoid armature is supported by three ball bearings that travel around and down inclined ball races. When power is applied, a powerful linear electromagnetic force pulls in the armature. Rotation continues until the balls have traveled to the deep ends of the races. The result is almost frictionless conversion from linear to rotary motion.

High Starting Torque

In ordinary electromagnets, magnetic pull increases sharply as the air gap closes. In Ledex rotary solenoids, this is compensated for by the compound angle of incline of the ball races. The incline of the ball races is steep at the beginning of the rotary stroke and gradually decreases as the balls approach the deep end of the ball races, thus transferring torque to the start of the rotary stroke where it is usually needed.

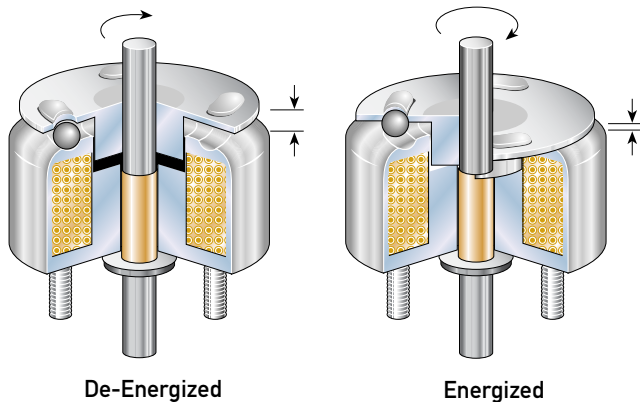

Ledex® Rotary Solenoids Design Considerations

Rotary Stroke Considerations

Determine whether clockwise or counterclockwise rotation (as viewed from the armature side, opposite the mounting studs) is required.

Match the stroke of the solenoid selected to the rotary stroke required for the application. For example: do not use a 45° stroke solenoid when only 35° of stroke is needed.

The complete rotary stroke of the solenoid should be utilized. It is the contour of the ball race that determines the torque output, but if the armature is not allowed to completely energize or de-energize, the starting torque and ending torque will deviate from the designed torque output.

In some applications, however, users of standard Ledex solenoids have achieved good results with certain methods of restricting the rotary

stroke. If some mechanical means is used to prevent the balls from reaching the deepest part of the races, increased life expectancy and quieter operation can be achieved. However, if the stroke is restricted, it is often necessary that some additional bearing method be employed to keep the balls in phase. Our application engineers will be glad to assist you with any unusual requirements.

When strokes other than those shown in this catalog are needed in production quantities, it is usually best to consider tooling to produce the exact stroke needed.

Starting Torque

When determining an application's torque requirement, apply a 1.5 safety factor. For example: a load requiring 4.5 lb-in of torque should utilize a solenoid providing 4.5 x 1.5 or 6.75 lb-in of torque.

Other Design Considerations

Snap-Acting Engagement

Rotary solenoids have fast acting engagement. If a controlled speed is required in a rotary stroke application, consider Ledex BTA rotary actuators.

Unobstructed Axial Stroke

Axial stroke is the linear distance that the armature travels to the center of the coil as the solenoid is energized and the three bearing balls travel to the lower ends of the races.

The application should allow clearance for axial stroke, which is rarely a problem due to the relatively small magnitude of travel. Axial stroke is listed for each solenoid size and rotary stroke on the appropriate specification pages.

Solenoids without axial stroke, such as our BTA, can be tailored to your application if longitudinal movement must be avoided.

Preloaded Axial Stroke

A rotary solenoid's armature produces smoother action if it is preloaded axially. It is important that the three bearing balls be kept in phase throughout the entire stroke. If they are allowed to move freely in the raceway, operation may become erratic.

Torque and Stroke

Torque is inversely proportional to the total length of the rotary stroke. If, for example, a rotary solenoid with a 90° stroke produces a gross starting torque of 0.7 lb-in, it will have approximately 1.5 lb-in of torque if it has a 45° stroke, and 3.0 lb-in with a 25° stroke.

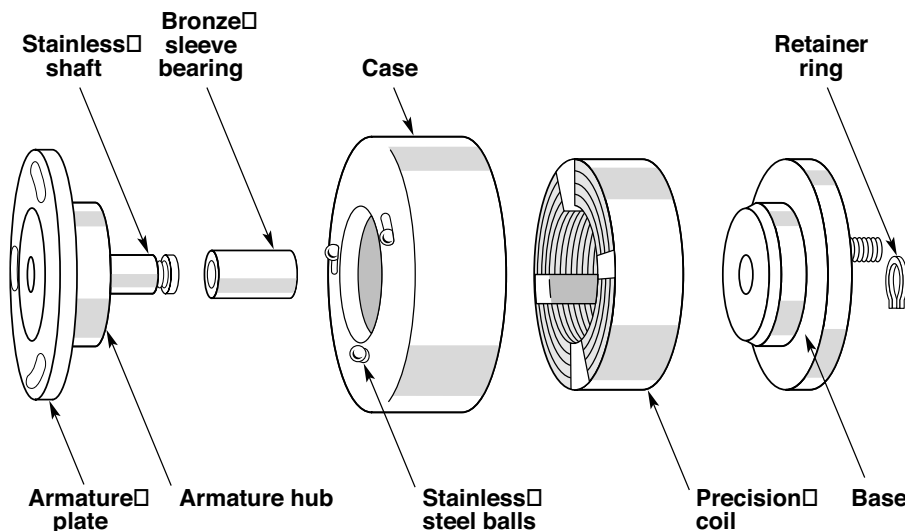
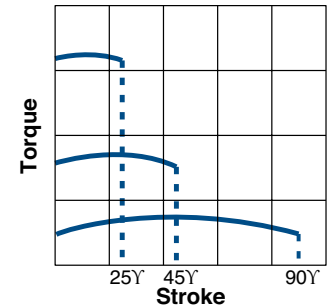

Ledex® Rotary Solenoids Design Considerations

Other Design Considerations (continued)

Torque and Duty Cycle

Ledex rotary solenoids are engineered to deliver a relatively flat output curve at 25% duty.

Under highly intermittent usage such as 10% or 5% duty, power and magnetic saturation are increased. This results in a higher starting torque, but a faster reduction of torque as the armature progresses through the rotary stroke. Since most loads have some inertia, the effect of less torque toward the end of the stroke is usually negligible. At continuous duty, magnetic saturation is lower and the torque output typically increases slightly toward the end of stroke.

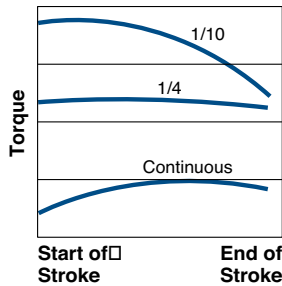

Temperature Considerations

Rotary solenoids are designed for operation in ambient temperatures ranging from -55°C to 80°C, provided the coil temperature does not exceed 120°C. Note that standard and elongated solenoids have PVC lead wires which have a maximum rating of 105°C. Special order Teflon leads are available (with maximum temperature rating of 200°C to allow for a 175°C coil temperature.)

Armature Drive Pin

Armature pins are commonly used as the main power take-off to perform secondary drive operations. They also provide a convenient adaptor for levers or bars which can convert the rotary stroke into linear motion. With appropriately designed linkages, a limited rotary stroke can produce several inches of linear travel.

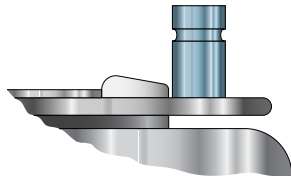

Armature Cover

Armature covers are available on all models, sizes and styles. They keep adjacent components or wires from interfering with the rotary and axial motion of the solenoid armature. They are also recommended for dirty or dusty environments. Armature cover models with armature end shaft extensions are equipped with a felt washer to act as a seal against the entry of dust around the shaft.

Coil Style

Ledex offers three rotary solenoid coil designs to accommodate most price and performance considerations.

Bobbin Coil Style solenoids (Sizes 3B and 5B only) offer good performance, long life and cost less than Precision Standard Coil

Style solenoids. However, Bobbin Style solenoids provide somewhat less torque in a slightly taller package. Bobbin Style Solenoids are equipped with either solder lug terminals or lead wires.

Precision Standard Coil Style solenoids (Sizes 5S through 7S) are designed with precision wound coils to provide excellent performance and long life. Precision Standard solenoids are equipped with 10" PVC insulated lead wires.

Precision Elongated Coil Style solenoids (sizes 1E through 4E) also have precision-wound coils like our standard models, except the coil has 30% more copper. The larger coil enables Elongated styles to operate with additional torque at most power levels to provide an additional safety factor when compared to standard S style torque ratings. Consequently, Precision Elongated Coil Solenoids are generally recommended for applications which have relatively long duty cycle ON times. Precision elongated coils, in comparison to standard coils, weigh 20–25% more, have the same diameter and mounting configurations and are equipped with 10" PVC insulated lead wires.

Configurations

Rotary solenoids are available in seven standard configurations for most sizes:

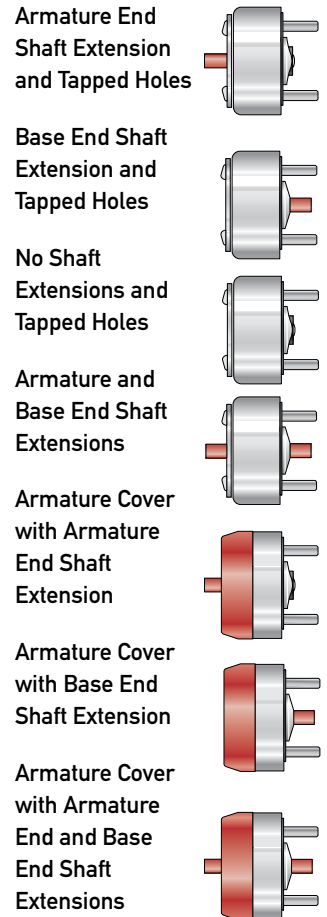

These icons are used throughout the rotary solenoid section to help distinguish the seven configurations. All standard configurations include a return spring (See return spring torque specifications on page D7.) Models without an armature cover are equipped with three tapped holes in the armature face for load attachment purposes.

ROTARY Solenoids

Ledex® Rotary Solenoids Design Considerations

Life Ratings

Rotary solenoids are laboratory tested under spring load conditions at 25% duty cycle at 20° C ambient temperature to determine life ratings. Bobbin, Precision Standard, and Precision Elongated coil solenoids are rated for 1 million actuations.

Actual life, however, is greatly affected by the application and environment factors such as exposure to extreme temperatures, dirt, dust, etc. Depending on these factors, Precision Standard and Precision Elongated coil solenoids can provide up to 20 million actuations.

Long Life Versions

Precision Standard and Precision Elongated coil solenoids are also available in long life versions which provide 50 million actuations (or 100 million actuations if lubricated every 10 million actuations).

Long life models incorporate precision needle bearings and special materials to reduce wear and extend life. The needle bearing is particularly helpful in overcoming side load and starting torque problems.

Long life models provide approximately 90% of the charted torque listed in the performance charts. Long life models are slightly more expensive, but can cost less in terms of machine down time and replacement time. Long life versions are available in strokes up to 45°. Please consult the factory for longer strokes.

Duty Cycle

Duty cycle is determined by solenoid ON time/(ON + OFF time).

For example: a solenoid is actuated for 30 seconds, then off for 90 seconds.
 $30 \text{ sec ON} / (30 \text{ Sec ON} + 90 \text{ sec OFF}) = 30/120 = 1/4 \text{ or } 25\% \text{ duty cycle}$

Ledex rates rotary solenoids for various duty cycles ranging from 100% to 5% duty.

If you cannot find an appropriate Style B Bobbin Coil solenoid which provides satisfactory torque and power, consider S Style Precision Standard Coil, or E Style Precision Elongated Coil models.

Maximum ON Time and Duty Cycle

Note that the maximum ON time for a particular application can be a factor which overrides the duty cycle rating.

For example, the maximum ON time for a given rotary solenoid when pulsed continuously at 25% duty cycle at given wattage is 36 seconds. If, however, the solenoid is given a single pulse at the same wattage with the unit at ambient temperature (20°C), then the maximum ON time is extended somewhat to 44 seconds. Maximum ON time ratings are charted by duty cycle on the following selection pages as well as on the individual specification pages.

Power Requirement

Standard solenoids are available in coil awgs ranging, in most instances, from #23 up to #33 to accommodate your input power. Refer to selection charts on the following pages. The coil awg number will determine the power rating of the coil. The coil awg number must be specified when ordering a unit. Many other awg coil sizes are available; please contact an application engineer to discuss your requirements.

In-Stock Models

Many rotary solenoids are available from distribution inventory. If you're not sure of your exact requirement, you may consider using a stock model prototype as a quick and very inexpensive means to determine your exact requirements.

Note that the last two digits of the model number correspond to the coil awg number. Refer to the specification page of the model to review performance data at that given awg.

Return Springs

Return springs are employed to return the solenoid armature to its de-energized position, and can also serve to return light loads. Standard nominal settings listed below are accurate to ±20%.

Size/Style	Spring Torque (oz-in)
1E	1.0
2E	1.0
3B: 3E	2.0
4E	3.0
5B: 5S	4.0
6S	8.0
7S	12.0

To meet exacting application requirements, rotary solenoids can be equipped with lesser or higher torsion return springs.

Contact our application engineers for your specific requirements.

Ledex® Rotary Solenoids Modifications & Custom Capabilities

Modifications and Customized Units

For modifications including heavy duty return springs, drive pins, etc. please contact our application engineers for assistance, as these standard modifications require a custom part number.

And, if you can't find exactly what you're looking for among our catalog products, please give our application engineers a call. Ledex custom fabricated solenoids are designed, built, tested, packaged, and shipped to your exact specifications. Whether it's as simple as adding a special connector or mounting bracket, or fabricating a complete assembly, we can build the right product to meet both your design and budget objectives.

Three Tapped Holes in Armature Plate

Attachment screws used should not extend below the bottom surface of the armature plate or they may interfere with the rotary stroke.

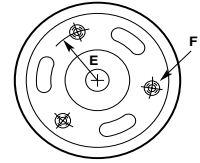

Solenoid Size	1E	2E	3B 3E	4E	5B 5S	6S	7S
Radius (E)	21/64	3/8	7/16	17/32	9/16	3/4	15/16
Thread Size (F)	#3-48	#3-48	#3-48	#5-40	#6-32	#8/32	#10-32

Return Springs

Scroll Type Standard or Heavy Duty Fixed Springs

The primary purpose of the return spring is to return the solenoid armature; it can also be used to return light loads. Standard nominal settings, which are accurate to within $\pm 20\%$, are charted below opposite "standard." Springs with greater torsion values can be supplied (see values opposite "Heavy Duty" below).

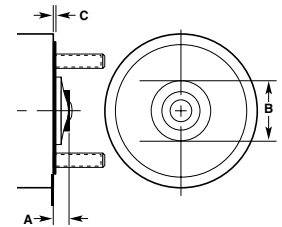

Solenoid Size	1E	2E	3B 3E	4E	5B 5S	6S	7S
Dim. A	5/32	5/32	11/64	13/64	7/32	1/4	5/16
Dim. B	35/64	35/64	43/64	13/16	7/8	1-1/32	1-11/64
Dim. C	1/64	1/64	1/64	1/32	1/32	1/32	1/32

Nominal Spring Setting: $\pm 20\%$ oz-in

Standard	1.0	1.0	2.0	3.0	4.0	8.0	12.0
Heavy Duty	—	—	2	4	5	8	16

Ledex® Rotary Solenoids Selection

How to Select Rotary Solenoids

1. Use the chart on page D9 to determine which coil style and frame size best satisfies your application requirement. Turn to the specification pages listed for model selection.

2. On the individual specification pages, use the Performance Chart (like the one shown at right), to select one of the five columns which provides the appropriate duty cycle for your application (for example 25%). Reading down this column, locate the torque for the stroke you need.

3. Use the model number and configuration chart (like the one at the bottom of this page) to select the model number corresponding to your desired design, stroke, and direction of rotation.

4. Using the Coil Specification Chart (like the one at right), find your selected duty cycle column. Reading down this column provides a variety of specification data. Following further down the column into the VDC ratings, select the voltage which most closely matches your supply voltage (for example, for a 24 VDC supply, select 26.0). Read across to the left to select the coil awg suffix for this voltage.

5. Replace the last two digits of the model number (XX) with the coil awg number to complete the model number. (For this example, specify model number: H-15039-033.

Performance Specifications

Stroke	Holding Torque ² (lb-in)	Starting Torque (lb-in) @ 20°C Maximum Duty Cycle				
		100%	50%	25%	10%	5%
25°	0.28	*	0.2	0.4	0.8	1.1
35°	*	*	*	*	*	*
45°	0.15	*	0.1	0.2	0.4	0.6

Coil Specifications

	100%	50%	25%	10%	5%
Maximum Duty Cycle	∞	100	36	7	2.5
Maximum ON Time (sec) when pulsed continuously	∞	162	44	8	2.8
Maximum ON Time (sec) for single pulse	∞	162	44	8	2.8
Watts (@ 20°C)	*	10.5	21	54	108
Ampere Turns (@ 20°C)	*	492	695	1,105	1560

Coil Data		# Turns	VDC (Nom)	VDC (Nom)	VDC (Nom)	VDC (Nom)	VDC (Nom)
avg (0XX)	Resistance (@20°C)						
25	0.83	140	*	2.9	4.1	6.5	9.2
26	1.38	186	*	3.7	5.2	8.2	11.6
27	1.91	210	*	4.5	6.3	10.1	14.2
28	3.17	273	*	5.7	8.1	12.8	18.1
29	5.17	352	*	7.2	10.2	16.2	23.0
30	8.25	441	*	9.2	13.0	21.0	29.0
31	12.95	550	*	11.6	16.4	26.0	37.0
32	20.71	682	*	14.9	21.0	34.0	47.0
33	30.60	828	*	18.2	26.0	41.0	58.0
34	50.95	1078	*	23.0	33.0	52.0	74.0
35	83.92	1392	*	30.0	42.0	67.0	94.0

- Armature cover
- Armature end shaft
- Return Spring

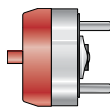

- Armature cover
- Base end shaft
- Return spring

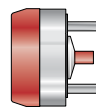

- Armature cover
- Double shaft
- Return spring

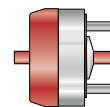

Stroke/ Direction*	Nom. Axial Stroke	Standard		Long Life		Standard		Long Life	
		Standard	Long Life	Standard	Long Life	Standard	Long Life		
25°CW	0.025"	H-1142-0XX	L-1142-0XX	H-1140-0XX	L-1140-0XX	H-15097-0XX	L-15097-0XX	H-3334-0XX	L-3334-0XX
25°CCW	0.025"	H-1145-0XX	L-1145-0XX	H-1144-0XX	L-1144-0XX	H-15207-0XX	L-15207-0XX	H-15208-0XX	L-15208-0XX
35°CW	0.030"	H-15201-0XX	L-15201-0XX	H-15205-0XX	L-15205-0XX	H-15207-0XX	L-15207-0XX	H-15208-0XX	L-15208-0XX
35°CCW	0.030"	H-15202-0XX	L-15202-0XX	H-15206-0XX	L-15206-0XX	H-15207-0XX	L-15207-0XX	H-15208-0XX	L-15208-0XX
45°CW	0.025"	H-1148-0XX	L-1148-0XX	H-1147-0XX	L-1147-0XX	H-15039-0XX	L-15039-0XX	H-15148-0XX	L-15148-0XX
45°CCW	0.025"	H-1150-0XX	L-1150-0XX	H-1149-0XX	L-1149-0XX	H-15148-0XX	L-15148-0XX	H-15148-0XX	L-15148-0XX

*Direction of rotation (cw – clockwise or ccw – counterclockwise) is viewed from the armature end of the solenoid opposite the mounting studs.

Note: The XX in the part number suffix must be filled in with the awg of your choice.

Ledex® Rotary Solenoids Selection

Rotary Solenoids Selection Overview

Size/ Series	Diameter ¹ (inches)	Height ¹ (inches)	Stroke	Direction CW CCW		Holding Torque (lb-in)	Available Torque ² (lb-in)					Energizing Time (msec) @ Specified Duty Cycles					Return Spring (lb-in)	
							100% Duty	50% Duty	25% Duty	10% Duty	5% Duty	100% Duty	50% Duty	25% Duty	10% Duty	5% Duty		
1E ●	1.000	0.625	25°	•	•	0.3	*	0.2	0.4	0.8	1.1	12.6	9.9	7.3	5.7	4.7	0.06	
			35°	•	•	*	*	*	*	*	*	*	*	*	*	*	*	*
			45°	•	•	0.2	*	0.1	0.2	0.4	0.6	19.8	14.2	10.0	7.2	6.0	0.06	
2E ●	1.125	0.656	25°	•	•	0.5	0.2	0.4	0.7	1.4	1.7	13.1	9.5	7.5	5.9	5.0	0.06	
			35°	•	•	*	0.2	0.3	0.5	1.1	1.3	*	*	*	*	*	*	
			45°	•	•	0.3	0.1	0.2	0.4	0.7	0.9	23.2	15.0	11.0	8.4	7.0	0.06	
3B	1.312	0.875	25°	•	•	0.9	0.4	0.7	1.3	2.7	3.2	16.5	11.3	8.9	6.8	5.9	0.12	
			35°	•	•	0.6	0.3	0.6	1.0	2.0	2.3	*	*	*	*	*	*	
			45°	•	•	0.4	0.2	0.4	0.8	1.4	1.7	24.0	15.6	12.1	9.4	7.7	0.12	
			67½°	•	•	0.4	0.1	0.2	0.4	0.5	0.8	*	*	*	*	*	*	
			95°	•	•	0.4	0.1	0.2	0.4	0.5	0.8	*	*	*	*	*	*	
3E	1.312	0.797	25°	•	•	0.9	0.4	0.8	1.4	2.7	3.2	16.9	12.0	9.3	7.1	6.2	0.12	
			35°	•	•	0.7	0.3	0.6	1.0	2.0	2.3	*	*	*	*	*	*	
			45°	•	•	0.6	0.2	0.4	0.8	1.4	1.8	29.8	17.8	13.1	10.0	8.1	0.12	
			67½°	•	•	0.5	0.1	0.2	0.4	0.7	0.9	*	*	*	*	*	*	
			95°	•	•	0.5	0.1	0.2	0.4	0.7	0.9	*	*	*	*	*	*	
4E	1.562	0.953	25°	•	•	2.0	0.9	1.7	3.1	4.5	5.2	19.1	13.9	11.2	8.3	7.2	0.18	
			35°	•	•	*	0.6	1.1	2.0	3.1	3.5	*	*	*	*	*	*	
			45°	•	•	1.0	0.4	0.9	1.6	2.6	3.1	28.9	20.3	15.4	11.3	9.2	0.18	
			55°	•	•	*	*	*	*	*	*	*	*	*	*	*	*	
			67½°	•	•	*	0.2	0.4	0.8	1.6	1.9	*	*	*	*	*	*	
			95°	•	•	0.9	0.2	0.3	0.6	1.0	1.2	*	*	*	*	*	*	
5B	1.875	1.203	25°	•	•	4.0	1.8	3.5	5.8	8.3	10.0	19.6	14.9	12.0	9.4	7.7	0.25	
			35°	•	•	*	0.9	2.1	4.1	6.9	8.3	*	*	*	*	*	*	
			45°	•	•	3.0	0.7	1.7	3.2	5.0	6.0	29.0	21.2	16.5	12.6	10.2	0.25	
			67½°	•	•	*	0.5	1.1	2.0	3.3	4.0	*	*	*	*	*	*	
			95°	•	•	2.0	0.2	0.4	0.9	1.6	1.9	*	*	*	*	*	*	
5S	1.875	1.047	25°	•	•	5.0	1.9	4.1	7.3	12.1	13.2	18.6	14.3	11.5	9.0	7.2	0.25	
			35°	•	•	*	1.2	2.6	4.5	7.8	9.2	*	*	*	*	*	*	
			45°	•	•	3.0	0.7	1.7	3.4	6.3	6.9	28.1	20.3	15.6	12.0	10.0	0.25	
			55°	•	•	*	*	*	*	*	*	*	*	*	*	*	*	
			67½°	•	•	*	0.5	1.2	2.2	3.9	4.9	*	*	*	*	*	*	
			75°	•	•	*	*	*	*	*	*	*	*	*	*	*	*	
			95°	•	•	2.0	0.2	0.5	1.0	1.9	2.6	62.4	36.5	26.1	18.7	15.0	0.25	
6S	2.250	1.343	25°	•	•	9.0	4.6	8.9	16.2	27.8	30.6	24.1	18.6	14.8	11.4	9.5	0.50	
			35°	•	•	*	3.4	6.5	12.0	18.6	20.5	*	*	*	*	*	*	
			45°	•	•	6.0	1.7	3.5	6.5	11.0	12.1	38.1	27.4	21.6	16.5	13.5	0.50	
			55°	•	•	*	*	*	*	*	*	*	*	*	*	*	*	
			67½°	•	•	*	1.6	3.1	5.6	8.8	9.7	*	*	*	*	*	*	
			95°	•	•	3.0	0.9	1.7	3.3	5.2	5.7	*	*	*	*	*	*	
7S	2.750	1.766	25°	•	•	20.0	11.0	23.8	33.2	42.4	46.6	32.3	25.1	20.3	15.6	13.2	0.75	
			35°	•	•	*	6.0	12.0	22.0	38.0	42.0	*	*	*	*	*	*	
			45°	•	•	13.0	5.0	8.8	16.4	29.8	32.8	45.1	33.9	27.2	20.2	16.9	0.75	
			55°	•	•	*	*	*	*	*	*	*	*	*	*	*	*	
			67½°	•	•	*	2.5	5.1	9.8	17.5	19.3	*	*	*	*	*	*	
			95°	•	•	6.0	1.5	3.5	6.4	10.5	11.6	81.6	58.8	44.8	33.0	27.3	0.75	

All data is at 20°C coil temperature. Torque outputs degrade with elevated temperatures. All specifications subject to change without notice.

¹ Without armature cover

² Torque values and energizing times shown for S and E Series are for Standard Life units. Long Life models provide approximately 10% less torque, but offer 5 to 10 times longer life. Long Life models are only available in strokes up to 45°.

* Consult factory for sizes and strokes not shown.

All catalog products manufactured after April 1, 2006 are RoHS Compliant

● Well-suited for battery operation. See the "Battery Operated Solenoids" section for complete information.



Ledex® Rotary Solenoids Size 1E Precision Elongated Coil

Performance Specifications

Stroke	Holding Torque ² (lb-in)	Starting Torque (lb-in) ¹ @ 20°C Maximum Duty Cycle				
		100%	50%	25%	10%	5%
25°	0.28	*	0.2	0.4	0.8	1.1
35°	*	*	*	*	*	*
45°	0.15	*	0.1	0.2	0.4	0.6

All data is at 20°C coil temperature. Force (torque) outputs degrade with elevated temperatures.

¹ Gross starting torques are shown. For net available starting torque, subtract return spring torque of 0.06 lb.-in. ±20%.

² Holding torque is shown at the stabilized temperature of 105°C and continuous duty.

* Consult factory.

● Well-suited for battery operation. See the "Battery Operated Solenoids" section for complete information.



All catalog products manufactured after April 1, 2006 are RoHS Compliant

How to Order

- Using the Performance Chart to the left, select one of the five columns which provides the appropriate duty cycle for your application. Reading down this column locate the torque for the stroke you need. For net available starting torque, subtract return spring torque of 0.06 lb.-in. ±20% (if torque is insufficient go to next larger solenoid size).
- Use the chart below to select the model number corresponding to your desired design, stroke and direction of rotation (as viewed from armature end, opposite mounting studs).
- Using the Specification Chart to the right, select the same duty cycle column. Follow down the column into the VDC ratings. Select the voltage which most closely matches your supply voltage. Read across to the left to select the coil awg suffix.
- Replace the last two digits of the model number (XX) with the coil awg number to complete the part number.

Please see www.ledex.com (click on Stock Products tab) for our list of stock products available through our North American distributors.

ROTARY Solenoids

- Armature cover
- Armature end shaft
- Return spring

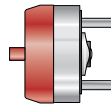

- Armature cover
- Base end shaft
- Return spring

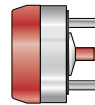

- Armature cover
- Double shaft
- Return spring

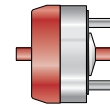

Stroke/ Direction*	Nom. Axial Stroke	Standard		Long Life		Standard		Long Life	
		Standard	Long Life	Standard	Long Life	Standard	Long Life	Standard	Long Life
25° CW	0.025"	H-1142-0XX	L-1142-0XX	H-1140-0XX	L-1140-0XX	H-15097-0XX	L-15097-0XX	H-15097-0XX	L-15097-0XX
25° CCW	0.025"	H-1145-0XX	L-1145-0XX	H-1144-0XX	L-1144-0XX	H-3334-0XX	L-3334-0XX	H-3334-0XX	L-3334-0XX
35° CW	0.030"	H-15201-0XX	L-15201-0XX	H-15205-0XX	L-15205-0XX	H-15207-0XX	L-15207-0XX	H-15207-0XX	L-15207-0XX
35° CCW	0.030"	H-15202-0XX	L-15202-0XX	H-15206-0XX	L-15206-0XX	H-15208-0XX	L-15208-0XX	H-15208-0XX	L-15208-0XX
45° CW	0.025"	H-1148-0XX	L-1148-0XX	H-1147-0XX	L-1147-0XX	H-15039-0XX	L-15039-0XX	H-15039-0XX	L-15039-0XX
45° CCW	0.025"	H-1150-0XX	L-1150-0XX	H-1149-0XX	L-1149-0XX	H-15148-0XX	L-15148-0XX	H-15148-0XX	L-15148-0XX

* Direction of rotation (cw – clockwise or ccw – counterclockwise) is viewed from the armature end of the solenoid opposite the mounting studs.

Note: The XX in the part number suffix must be filled in with the awg of your choice.

Ledex® Rotary Solenoids Size 1E Precision Elongated Coil

Coil Specifications

Maximum Duty Cycle	100%	50%	25%	10%	5%
Maximum ON Time (sec) when pulsed continuously ¹	∞	100	36	7	2.5
Maximum ON Time (sec) for single pulse ²	∞	162	44	8	2.8
Watts (@ 20°C)	*	10.5	21	54	108
Ampere Turns (@ 20°C)	*	492	695	1105	1560

Coil Data

awg (0XX) ³	Resistance (@20°C)	# Turns ⁴	VDC (Nom)	VDC (Nom)	VDC (Nom)	VDC (Nom)	VDC (Nom)
25	0.83	140	*	2.9	4.1	6.5	9.2
26	1.38	186	*	3.7	5.2	8.2	11.6
27	1.91	210	*	4.5	6.3	10.1	14.2
28	3.17	273	*	5.7	8.1	12.8	18.1
29	5.17	352	*	7.2	10.2	16.2	23.0
30	8.25	441	*	9.2	13.0	21.0	29.0
31	12.95	550	*	11.6	16.4	26.0	37.0
32	20.71	682	*	14.9	21.0	34.0	47.0
33	30.60	828	*	18.2	26.0	41.0	58.0
34	50.95	1078	*	23.0	33.0	52.0	74.0
35	83.92	1392	*	30.0	42.0	67.0	94.0

General Specifications

Dielectric Strength	1000 VRMS, all coils
Recommended Minimum Heat Sink	Maximum watts dissipated by solenoid are based on an unrestricted flow of air at 20°C, with solenoid mounted on the equivalent of an aluminum plate measuring 3" square by 1/8" thick.
Coil Resistance	±5% tolerance
Starting Torque	Gross torque values are shown. For net starting torque, subtract return spring torque
Return Spring Torque	0.06 pound-inches ±20%
Weight	1.5 oz (42.5 gms)
Dimensions	See page D28

- 1 Continuously pulsed at stated watts and duty cycle.
 - 2 Single pulse at stated watts (with coil at ambient room temperature 20°C).
 - 3 Other coil awg sizes available, consult factory.
 - 4 Reference number of turns.
- * Consult factory.

ROTARY Solenoids

All specifications subject to change without notice.

- No shafts
- 3 tapped holes
- Return spring

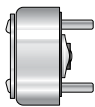

- Armature end shaft
- 3 tapped holes
- Return spring

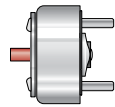

- Base end shaft
- 3 tapped holes
- Return spring

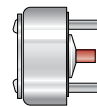

- Double shaft
- 3 tapped holes
- Return spring

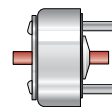

Standard		Long Life		Standard		Long Life		Standard		Long Life					
H-1143-0XX	L-1143-0XX	H-15089-0XX	L-15089-0XX	H-15211-0XX	L-15211-0XX	H-15215-0XX	L-15215-0XX	H-1146-0XX	L-1146-0XX	H-3311-0XX	L-3311-0XX	H-15084-0XX	L-15084-0XX	H-15216-0XX	L-15216-0XX
H-15200-0XX	L-15200-0XX	H-15204-0XX	L-15204-0XX	H-15212-0XX	L-15212-0XX	H-1305-0XX	L-1305-0XX	H-15203-0XX	L-15203-0XX	H-15210-0XX	L-15210-0XX	H-15213-0XX	L-15213-0XX	H-15217-0XX	L-15217-0XX
H-1141-0XX	L-1141-0XX	H-3380-0XX	L-3380-0XX	H-15085-0XX	L-15085-0XX	H-15218-0XX	L-15218-0XX	H-1151-0XX	L-1151-0XX	H-1282-0XX	L-1282-0XX	H-15214-0XX	L-15214-0XX	H-15219-0XX	L-15219-0XX

Ledex® Rotary Solenoids Size 2E Precision Elongated Coil

Performance Specifications

Stroke	Holding Torque ² (lb-in)	Starting Torque (lb-in) ¹ @ 20°C Maximum Duty Cycle				
		100%	50%	25%	10%	5%
25°	0.5	0.2	0.4	0.7	1.4	1.7
35°	*	0.2	0.3	0.5	1.1	1.3
45°	0.3	0.1	0.2	0.4	0.7	0.9

All data is at 20°C coil temperature. Force (torque) outputs degrade with elevated temperatures.

¹ Gross starting torques are shown. For net available starting torque, subtract return spring torque of 0.06 lb.-in. ±20%.

² Holding torque is shown at the stabilized temperature of 105°C and continuous duty.

* Consult factory.

● Well-suited for battery operation. See the "Battery Operated Solenoids" section for complete information.



All catalog products manufactured after April 1, 2006 are RoHS Compliant

How to Order

- Using the Performance Chart to the left, select one of the five columns which provides the appropriate duty cycle for your application. Reading down this column locate the torque for the stroke you need. For net available starting torque, subtract return spring torque of 0.06 lb.-in. ±20% (if torque is insufficient go to next larger solenoid size).
- Use the chart below to select the model number corresponding to your desired design, stroke and direction of rotation (as viewed from armature end, opposite mounting studs).
- Using the Specification Chart to the right, select the same duty cycle column. Follow down the column into the VDC ratings. Select the voltage which most closely matches your supply voltage. Read across to the left to select the coil awg suffix.
- Replace the last two digits of the model number (XX) with the coil awg number to complete the part number.

Please see www.ledex.com (click on Stock Products tab) for our list of stock products available through our North American distributors.

- Armature cover
- Armature end shaft
- Return spring

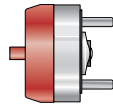

- Armature cover
- Base end shaft
- Return spring

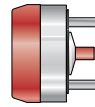

- Armature cover
- Double shaft
- Return spring

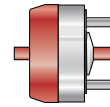

Stroke/ Direction*	Nom. Axial Stroke	Standard		Long Life		Standard		Long Life	
		Standard	Long Life	Standard	Long Life	Standard	Long Life	Standard	Long Life
25° CW	0.025"	H-1244-0XX	L-1244-0XX	H-1024-0XX	L-1024-0XX	H-2390-0XX	L-2390-0XX	H-2390-0XX	L-2390-0XX
25° CCW	0.025"	H-3259-0XX	L-3259-0XX	H-2452-0XX	L-2452-0XX	H-2389-0XX	L-2389-0XX	H-2389-0XX	L-2389-0XX
35° CW	0.025"	H-1294-0XX	L-1294-0XX	H-2116-0XX	L-2116-0XX	H-3405-0XX	L-3405-0XX	H-3405-0XX	L-3405-0XX
35° CCW	0.025"	H-1159-0XX	L-1159-0XX	H-15004-0XX	L-15004-0XX	H-15111-0XX	L-15111-0XX	H-15111-0XX	L-15111-0XX
45° CW	0.025"	H-2264-0XX	L-2264-0XX	H-2117-0XX	L-2117-0XX	H-1344-0XX	L-1344-0XX	H-1344-0XX	L-1344-0XX
45° CCW	0.025"	H-2265-0XX	L-2265-0XX	H-2450-0XX	L-2450-0XX	H-15046-0XX	L-15046-0XX	H-15046-0XX	L-15046-0XX

* Direction of rotation (cw – clockwise or ccw – counterclockwise) is viewed from the armature end of the solenoid opposite the mounting studs.

Note: The XX in the part number suffix must be filled in with the awg of your choice.

Ledex® Rotary Solenoids Size 2E Precision Elongated Coil

Coil Specifications

Maximum Duty Cycle	100%	50%	25%	10%	5%
Maximum ON Time (sec) when pulsed continuously ¹	∞	100	36	7	2.5
Maximum ON Time (sec) for single pulse ²	∞	162	44	8	2.8
Watts (@ 20°C)	7	14	28	70	140
Ampere Turns (@ 20°C)	425	602	849	1350	1904

Coil Data

awg (0XX) ³	Resistance (@20°C)	# Turns ⁴	VDC (Nom)	VDC (Nom)	VDC (Nom)	VDC (Nom)	VDC (Nom)
24	0.68	130	2.2	3.2	4.5	7.1	10.0
25	1.16	174	2.8	4.0	5.7	9.0	12.7
26	1.96	231	3.6	5.1	7.2	11.5	16.2
27	3.16	296	4.5	6.4	9.0	14.4	20.0
28	5.10	378	5.7	8.1	11.5	18.2	26.0
29	6.94	423	7.0	9.9	13.9	22.0	31.0
30	11.03	530	8.8	12.5	17.7	28.0	40.0
31	16.85	649	11.0	15.6	22.0	35.0	49.0
32	28.15	858	13.9	19.8	28.0	44.0	63.0
33	42.75	1036	17.5	25.0	35.0	56.0	79.0
34	69.56	1312	23.0	32.0	45.0	72.0	101.0
35	112.00	1674	29.0	40.0	57.0	91.0	128.0

General Specifications

Dielectric Strength	1000 VRMS, all coils
Recommended Minimum Heat Sink	Maximum watts dissipated by solenoid are based on an unrestricted flow of air at 20°C, with solenoid mounted on the equivalent of an aluminum plate measuring 3 ³ / ₈ " square by 1/ ₈ " thick.
Coil Resistance	±5% tolerance
Starting Torque	Gross torque values are shown. For net starting torque, subtract return spring torque
Return Spring Torque	0.06 pound-inches ±20%
Weight	2 oz (56.7 gms)
Dimensions	See page D29

- Continuously pulsed at stated watts and duty cycle.
- Single pulse at stated watts (with coil at ambient room temperature 20°C).
- Other coil awg sizes available, consult factory.
- Reference number of turns.

All specifications subject to change without notice.

- No shafts
- 3 tapped holes
- Return spring

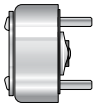

- Armature end shaft
- 3 tapped holes
- Return spring

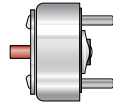

- Base end shaft
- 3 tapped holes
- Return spring

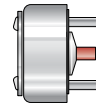

- Double shaft
- 3 tapped holes
- Return spring

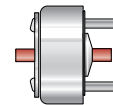

Standard	Long Life	Standard	Long Life	Standard	Long Life	Standard	Long Life
H-2168-0XX	L-2168-0XX	H-1094-0XX	L-1094-0XX	H-2933-0XX	L-2933-0XX	H-2411-0XX	L-2411-0XX
H-2346-0XX	L-2346-0XX	H-2670-0XX	L-2670-0XX	H-2748-0XX	L-2748-0XX	H-2537-0XX	L-2537-0XX
H-2193-0XX	L-2193-0XX	H-2685-0XX	L-2685-0XX	H-1088-0XX	L-1088-0XX	H-2994-0XX	L-2994-0XX
H-2483-0XX	L-2483-0XX	H-15094-0XX	L-15094-0XX	H-15615-0XX	L-15615-0XX	H-15220-0XX	L-15220-0XX
H-1079-0XX	L-1079-0XX	H-2362-0XX	L-2362-0XX	H-3265-0XX	L-3265-0XX	H-3244-0XX	L-3244-0XX
H-2744-0XX	L-2744-0XX	H-3112-0XX	L-3112-0XX	H-2436-0XX	L-2436-0XX	H-3245-0XX	L-3245-0XX

Ledex® Rotary Solenoids Size 3B Bobbin Coil

Performance Specifications

Stroke	Holding Torque ² (lb-in)	Starting Torque (lb-in) ¹ @ 20°C Maximum Duty Cycle				
		100%	50%	25%	10%	5%
25°	0.9	0.35	0.70	1.3	2.7	3.2
35°	0.6	0.25	0.55	1.0	2.0	2.3
45°	0.4	0.15	0.35	0.8	1.4	1.7
67½°	0.4	0.09	0.20	0.4	0.5	0.8

All data is at 20°C coil temperature. Force (torque) outputs degrade with elevated temperatures.

¹ Gross starting torques are shown. For net available starting torque, subtract return spring torque of 0.12 lb.-in. ±20%.

² Holding torque is shown at the stabilized temperature of 105°C and continuous duty.

* Consult factory.

How to Order

- Using the Performance Chart to the left, select one of the five columns which provides the appropriate duty cycle for your application. Reading down this column locate the torque for the stroke you need. For net available starting torque, subtract return spring torque of 0.12 lb.-in. ±20% (if torque is insufficient go to next larger solenoid size).
- Use the chart below to select the model number corresponding to your desired design, stroke and direction of rotation (as viewed from armature end, opposite mounting studs).
- Using the Specification Chart to the right, select the same duty cycle column. Follow down the column into the VDC ratings. Select the voltage which most closely matches your supply voltage. Read across to the left to select the coil awg suffix.
- Replace the last two digits of the model number (XX) with the coil awg number to complete the part number.

Please see www.ledex.com (click on Stock Products tab) for our list of stock products available through our North American distributors.

ROTARY Solenoids

All catalog products manufactured after April 1, 2006 are RoHS Compliant

- Armature cover
- Base end shaft
- Return spring

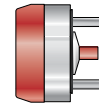

Stroke/ Direction*	Nom. Axial Stroke	
25° CW	0.032"	810-380-3XX
25° CCW	0.032"	810-385-3XX
35° CW	0.032"	810-381-3XX
35° CCW	0.032"	810-386-3XX
45° CW	0.032"	810-382-3XX
45° CCW	0.032"	810-387-3XX
67½° CW	0.032"	810-383-3XX
67½° CCW	0.032"	810-388-3XX

* Direction of rotation (cw – clockwise or ccw – counterclockwise) is viewed from the armature end of the solenoid opposite the mounting studs.

Note: The XX in the part number suffix must be filled in with the awg of your choice.

Ledex® Rotary Solenoids Size 3B Bobbin Coil

Coil Specifications

Maximum Duty Cycle	100%	50%	25%	10%	5%
Maximum ON Time (sec) when pulsed continuously ¹	∞	100	36	8	2.8
Maximum ON Time (sec) for single pulse ²	∞	162	44	9	3.2
Watts (@ 20°C)	10	20	40	100	200
Ampere Turns (@ 20°C)	550	785	1100	1740	2464

Coil Data

awg (0XX) ³	Resistance (@20°C)	# Turns ⁴	VDC (Nom)	VDC (Nom)	VDC (Nom)	VDC (Nom)	VDC (Nom)
23	0.65	136	2.6	3.7	5.2	8.3	11.8
24	1.13	188	3.3	4.7	6.6	10.5	14.8
25	1.86	238	4.3	6.1	8.6	13.6	19.3
26	2.95	300	5.4	7.7	10.8	17.1	24.0
27	4.67	377	6.8	9.7	13.6	22.0	31.0
28	7.40	466	8.7	12.5	17.5	28.0	39.0
29	11.46	576	10.9	15.6	22.0	35.0	49.0
30	18.40	720	14.1	20.0	28.0	45.0	63.0
31	29.60	960	17.0	24.0	34.0	54.0	76.0
32	45.60	1157	22.0	31.0	43.0	69.0	97.0
33	73.20	1470	28.0	39.0	55.0	87.0	123.0

General Specifications

Dielectric Strength	23-27 awg, 1000 VRMS; 28-33 awg, 1200 VRMS
Recommended Minimum Heat Sink	Maximum watts dissipated by solenoid are based on an unrestricted flow of air at 20°C, with solenoid mounted on the equivalent of an aluminum plate measuring 4 ⁵ / ₈ " square by 1 ¹ / ₈ " thick.
Coil Resistance	±10% tolerance
Starting Torque	Gross torque values are shown. For net starting torque, subtract return spring torque
Weight	4 oz (113.4 gm)
Return Spring Torque	0.12 pound-inches ±20%
Dimensions	See page D30

- ¹ Continuously pulsed at stated watts and duty cycle.
- ² Single pulse at stated watts (with coil at ambient room temperature 20°C).
- ³ Other coil awg sizes available, consult factory.
- ⁴ Reference number of turns.

All specifications subject to change without notice.

- No shafts
- 3 tapped holes
- Return spring

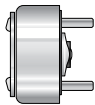

810-640-3XX
810-645-3XX
810-641-3XX
810-646-3XX
810-642-3XX
810-647-3XX
810-643-3XX
810-648-3XX

- Armature end shaft
- 3 tapped holes
- Return spring

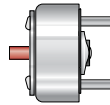

810-490-3XX
810-495-3XX
810-491-3XX
810-496-3XX
810-492-3XX
810-497-3XX
810-493-3XX
810-498-3XX

- Base end shaft
- 3 tapped holes
- Return spring

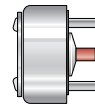

810-360-3XX
810-365-3XX
810-361-3XX
810-366-3XX
810-362-3XX
810-367-3XX
810-363-3XX
810-368-3XX

- Double shaft
- 3 tapped holes
- Return spring

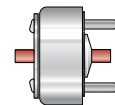

810-280-3XX
810-285-3XX
810-281-3XX
810-286-3XX
810-282-3XX
810-287-3XX
810-283-3XX
810-288-3XX

Ledex® Rotary Solenoids Size 3E Precision Elongated Coil

Performance Specifications

Stroke	Holding Torque ² (lb-in)	Starting Torque (lb-in) ¹ @ 20°C Maximum Duty Cycle				
		100%	50%	25%	10%	5%
25°	0.9	0.35	0.8	1.4	2.7	3.2
35°	0.7	0.25	0.6	1.0	2.0	2.3
45°	0.6	0.15	0.4	0.8	1.4	1.8
67½°	0.5	0.10	0.2	0.4	0.7	0.9

All data is at 20°C coil temperature. Force (torque) outputs degrade with elevated temperatures.

¹ Gross starting torques are shown. For net available starting torque, subtract return spring torque of 0.12 lb.-in. ±20%.

² Holding torque is shown at the stabilized temperature of 105°C and continuous duty.

* Consult factory.

How to Order

- Using the Performance Chart to the left, select one of the five columns which provides the appropriate duty cycle for your application. Reading down this column locate the torque for the stroke you need. For net available starting torque, subtract return spring torque of 0.12 lb.-in. ±20% (if torque is insufficient go to next larger solenoid size).
- Use the chart below to select the model number corresponding to your desired design, stroke and direction of rotation (as viewed from armature end, opposite mounting studs).
- Using the Specification Chart to the right, select the same duty cycle column. Follow down the column into the VDC ratings. Select the voltage which most closely matches your supply voltage. Read across to the left to select the coil awg suffix.
- Replace the last two digits of the model number (XX) with the coil awg number to complete the part number.

Please see www.ledex.com (click on Stock Products tab) for our list of stock products available through our North American distributors.

All catalog products manufactured after April 1, 2006 are RoHS Compliant

ROTARY Solenoids

- Armature cover
- Armature end shaft
- Return spring

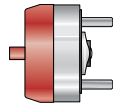

- Armature cover
- Base end shaft
- Return spring

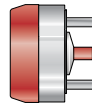

- Armature cover
- Double shaft
- Return spring

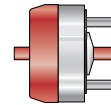

Stroke/ Direction*	Nom. Axial Stroke	Standard		Long Life		Standard		Long Life	
		Standard	Long Life	Standard	Long Life	Standard	Long Life	Standard	Long Life
25° CW	0.032"	H-2437-OXX	L-2437-OXX	H-2126-OXX	L-2126-OXX	H-15080-OXX	L-15080-OXX	H-3374-OXX	L-3374-OXX
25° CCW	0.032"	H-1245-OXX	L-1245-OXX	H-2276-OXX	L-2276-OXX	H-3401-OXX	L-3401-OXX	H-15005-OXX	L-15005-OXX
35° CW	0.032"	H-2562-OXX	L-2562-OXX	H-2127-OXX	L-2127-OXX	H-2711-OXX	L-2711-OXX	H-2712-OXX	L-2712-OXX
35° CCW	0.032"	H-3398-OXX	L-3398-OXX	H-2209-OXX	L-2209-OXX	H-2128-OXX	L-2128-OXX	H-15040-OXX	L-15040-OXX
45° CW	0.032"	H-2259-OXX	L-2259-OXX	H-2008-OXX	L-2008-OXX	H-2453-OXX	L-2453-OXX	H-3278-OXX	L-3278-OXX
45° CCW	0.032"	H-2419-OXX	L-2419-OXX	H-2453-OXX	L-2453-OXX	H-3279-OXX	L-3279-OXX	—	—
67½° CW	0.032"	H-3278-OXX	—	H-2128-OXX	—	H-15040-OXX	—	—	—
67½° CCW	0.032"	H-3279-OXX	—	H-3004-OXX	—	H-15107-OXX	—	—	—

* Direction of rotation (cw – clockwise or ccw – counterclockwise) is viewed from the armature end of the solenoid opposite the mounting studs.

Note: The XX in the part number suffix must be filled in with the awg of your choice.

Ledex® Rotary Solenoids Size 3E Precision Elongated Coil

Coil Specifications

Maximum Duty Cycle	100%	50%	25%	10%	5%		
Maximum ON Time (sec) when pulsed continuously ¹	∞	100	36	8	2.8		
Maximum ON Time (sec) for single pulse ²	∞	162	44	9	3.2		
Watts (@ 20°C)	9	18	36	90	180		
Ampere Turns (@ 20°C)	535	756	1070	1690	2397		
Coil Data							
awg (0XX) ³	Resistance (@20°C)	# Turns ⁴	VDC (Nom)	VDC (Nom)	VDC (Nom)	VDC (Nom)	VDC (Nom)
23	0.70	145	2.6	3.7	5.2	8.2	11.6
24	1.18	192	3.3	4.6	6.6	10.4	14.7
25	1.97	252	4.2	5.9	8.4	13.2	18.7
26	3.26	328	5.3	7.5	10.6	16.8	24.0
27	5.04	405	6.7	9.4	13.3	21.0	30.0
28	8.02	510	8.4	11.9	16.8	27.0	38.0
29	12.21	627	10.4	14.7	21.0	33.0	47.0
30	19.20	780	13.2	18.6	26.0	42.0	59.0
31	31.84	1008	16.9	24.0	34.0	53.0	76.0
32	46.97	1215	21.0	29.0	41.0	65.0	93.0
33	75.30	1530	26.0	37.0	53.0	83.0	118.0

General Specifications

Dielectric Strength	23-27 awg, 1000 VRMS; 28-33 awg, 1200 VRMS
Recommended Minimum Heat Sink	Maximum watts dissipated by solenoid are based on an unrestricted flow of air at 20°C, with solenoid mounted on the equivalent of an aluminum plate measuring 4 ⁵ / ₈ " square by 1/8" thick.
Coil Resistance	±5% tolerance
Starting Torque	Gross torque values are shown. For net starting torque, subtract return spring torque
Return Spring Torque	0.12 pound-inches ±20%
Weight	3.5 oz (99.2 gms)
Dimensions	See page D31

- Continuously pulsed at stated watts and duty cycle.
- Single pulse at stated watts (with coil at ambient room temperature 20°C).
- Other coil awg sizes available, consult factory.
- Reference number of turns.

All specifications subject to change without notice.

- No shafts
- 3 tapped holes
- Return spring

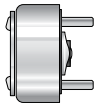

- Armature end shaft
- 3 tapped holes
- Return spring

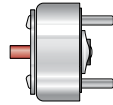

- Base end shaft
- 3 tapped holes
- Return spring

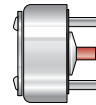

- Double shaft
- 3 tapped holes
- Return spring

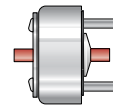

Standard		Long Life		Standard		Long Life		Standard		Long Life	
H-1075-0XX	L-1075-0XX	H-2512-0XX	L-2512-0XX	H-3169-0XX	L-3169-0XX	H-2412-0XX	L-2412-0XX	H-2159-0XX	L-2159-0XX	H-2992-0XX	L-2992-0XX
H-2216-0XX	L-2216-0XX	H-2634-0XX	L-2634-0XX	H-2330-0XX	L-2330-0XX	H-2722-0XX	L-2722-0XX	H-2444-0XX	L-2444-0XX	H-3044-0XX	L-3044-0XX
H-2556-0XX	L-2556-0XX	H-3045-0XX	L-3045-0XX	H-1135-0XX	L-1135-0XX	H-2616-0XX	L-2616-0XX	H-2268-0XX	L-2268-0XX	H-2906-0XX	L-2906-0XX
H-2289-0XX	—	H-2550-0XX	—	H-15071-0XX	—	H-2542-0XX	—	H-2288-0XX	—	H-1330-0XX	—
				H-3381-0XX	—	H-2940-0XX	—				

Ledex® Rotary Solenoids Size 4E Precision Elongated Coil

ROTARY Solenoids

Performance Specifications

Stroke	Holding Torque ² (lb-in)	Starting Torque (lb-in) ¹ @ 20°C Maximum Duty Cycle				
		100%	50%	25%	10%	5%
25°	2.0	0.9	1.7	3.1	4.5	5.2
35°	*	0.6	1.1	2.0	3.1	3.5
45°	1.0	0.4	0.9	1.6	2.6	3.1
55°	*	*	*	*	*	*
67½°	*	0.2	0.4	0.8	1.6	1.9
95°	0.9	0.2	0.3	0.6	1.0	1.2

All data is at 20°C coil temperature. Force (torque) outputs degrade with elevated temperatures.

- ¹ Gross starting torques are shown. For net available starting torque, subtract return spring torque of 0.18 lb.-in. ±20%.
- ² Holding torque is shown at the stabilized temperature of 105°C and continuous duty.
- * Consult factory.

How to Order

- Using the Performance Chart to the left, select one of the five columns which provides the appropriate duty cycle for your application. Reading down this column locate the torque for the stroke you need. For net available starting torque, subtract return spring torque of 0.18 lb.-in. ±20% (if torque is insufficient go to next larger solenoid size).
- Use the chart below to select the model number corresponding to your desired design, stroke and direction of rotation (as viewed from armature end, opposite mounting studs).
- Using the Specification Chart to the right, select the same duty cycle column. Follow down the column into the VDC ratings. Select the voltage which most closely matches your supply voltage. Read across to the left to select the coil awg suffix.
- Replace the last two digits of the model number (XX) with the coil awg number to complete the part number.

Please see www.ledex.com (click on Stock Products tab) for our list of stock products available through our North American distributors.

All catalog products manufactured after April 1, 2006 are RoHS Compliant

- Armature cover
- Armature end shaft
- Return spring

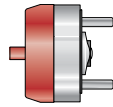

- Armature cover
- Base end shaft
- Return spring

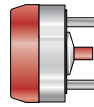

- Armature cover
- Double shaft
- Return spring

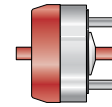

Stroke/ Direction*	Nom. Axial Stroke	Standard		Long Life		Standard		Long Life	
		Standard	Long Life	Standard	Long Life	Standard	Long Life		
25° CW	0.036"	H-3271-0XX	L-3271-0XX	H-3108-0XX	L-3108-0XX	H-15000-0XX	L-15000-0XX		
25° CCW	0.036"	H-3258-0XX	L-3258-0XX	H-2975-0XX	L-2975-0XX	H-15001-0XX	L-15001-0XX		
35° CW	0.036"	H-15011-0XX	L-15011-0XX	H-1132-0XX	L-1132-0XX	H-3378-0XX	L-3378-0XX		
35° CCW	0.036"	H-15015-0XX	L-15015-0XX	H-1258-0XX	L-1258-0XX	H-3379-0XX	L-3379-0XX		
45° CW	0.036"	H-1246-0XX	L-1246-0XX	H-3126-0XX	L-3126-0XX	H-2980-0XX	L-2980-0XX		
45° CCW	0.036"	H-1247-0XX	L-1247-0XX	H-2900-0XX	L-2900-0XX	H-2893-0XX	L-2893-0XX		
55° CW	0.036"	H-15222-0XX	—	H-15223-0XX	—	H-15224-0XX	—		
67½° CW	0.042"	H-15091-0XX	—	H-3074-0XX	—	H-3425-0XX	—		
67½° CCW	0.042"	H-1435-0XX	—	H-1521-0XX	—	H-15122-0XX	—		
95° CW	0.042"	H-1218-0XX	—	H-3117-0XX	—	H-3084-0XX	—		
95° CCW	0.042"	H-2563-0XX	—	H-2640-0XX	—	H-15127-0XX	—		

* Direction of rotation (cw – clockwise or ccw – counterclockwise) is viewed from the armature end of the solenoid opposite the mounting studs.

Note: The XX in the part number suffix must be filled in with the awg of your choice.

Ledex® Rotary Solenoids Size 4E Precision Elongated Coil

Coil Specifications

Maximum Duty Cycle	100%	50%	25%	10%	5%		
Maximum ON Time (sec) when pulsed continuously ¹	∞	100	36	9	3.2		
Maximum ON Time (sec) for single pulse ²	∞	162	44	10	3.5		
Watts (@ 20°C)	12.5	25	50	125	250		
Ampere Turns (@ 20°C)	714	1000	1425	2250	3200		
Coil Data							
awg (0XX) ³	Resistance (@20°C)	# Turns ⁴	VDC (Nom)	VDC (Nom)	VDC (Nom)	VDC (Nom)	VDC (Nom)
23	1.59	266	4.3	6.0	8.5	13.4	19.1
24	2.20	301	5.2	7.3	10.4	16.4	24.0
25	3.54	384	6.6	9.2	13.1	21.0	30.0
26	5.67	486	8.3	11.7	16.6	26.0	37.0
27	8.76	600	10.4	14.6	21.0	33.0	47.0
28	13.80	748	13.2	18.5	26.0	42.0	59.0
29	22.60	975	16.6	23.0	33.0	52.0	74.0
30	34.80	1190	21.0	29.0	42.0	66.0	94.0
31	56.70	1520	27.0	37.0	53.0	84.0	119.0
32	88.30	1908	33.0	46.0	66.0	104.0	148.0
33	138.00	2360	42.0	59.0	83.0	132.0	187.0

General Specifications

Dielectric Strength	23-24 awg, 1000 VRMS; 25-33 awg, 1200 VRMS
Recommended Minimum Heat Sink	Maximum watts dissipated by solenoid are based on an unrestricted flow of air at 20°C, with solenoid mounted on the equivalent of an aluminum plate measuring 6¼" square by 1/8" thick.
Coil Resistance	±5% tolerance
Starting Torque	Gross torque values are shown. For net starting torque, subtract return spring torque
Return Spring Torque	0.18 pound-inches ±20%
Weight	7 oz (198.4 gms)
Dimensions	See page D32

- Continuously pulsed at stated watts and duty cycle.
- Single pulse at stated watts (with coil at ambient room temperature 20°C).
- Other coil awg sizes available, consult factory.
- Reference number of turns.

All specifications subject to change without notice.

- No shafts
- 3 tapped holes
- Return spring

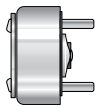

- Armature end shaft
- 3 tapped holes
- Return spring

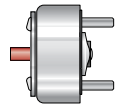

- Base end shaft
- 3 tapped holes
- Return spring

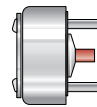

- Double shaft
- 3 tapped holes
- Return spring

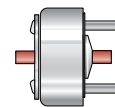

Standard	Long Life	Standard	Long Life	Standard	Long Life	Standard	Long Life
H-2650-0XX	L-2650-0XX	H-3324-0XX	L-3324-0XX	H-1174-0XX	L-1174-0XX	H-2413-0XX	L-2413-0XX
H-2741-0XX	L-2741-0XX	H-15120-0XX	L-15120-0XX	H-15125-0XX	L-15125-0XX	H-15135-0XX	L-15135-0XX
H-2952-0XX	L-2952-0XX	H-15016-0XX	L-15016-0XX	H-15230-0XX	L-15230-0XX	H-2995-0XX	L-2995-0XX
H-3352-0XX	L-3352-0XX	H-15229-0XX	L-15229-0XX	H-15231-0XX	L-15231-0XX	H-15236-0XX	L-15236-0XX
H-1168-0XX	L-1168-0XX	H-3071-0XX	L-3071-0XX	H-1310-0XX	L-1310-0XX	H-15237-0XX	L-15237-0XX
H-1226-0XX	L-1226-0XX	H-3125-0XX	L-3125-0XX	H-1309-0XX	L-1309-0XX	H-15238-0XX	L-15238-0XX
H-15225-0XX	—	H-15226-0XX	—	H-15227-0XX	—	H-15228-0XX	—
H-2310-0XX	—	H-3402-0XX	—	H-15233-0XX	—	H-15021-0XX	—
H-2967-0XX	—	H-15232-0XX	—	H-15234-0XX	—	H-15239-0XX	—
H-2862-0XX	—	H-2929-0XX	—	H-2626-0XX	—	H-2645-0XX	—
H-1263-0XX	—	H-2930-0XX	—	H-15235-0XX	—	H-1115-0XX	—

Ledex® Rotary Solenoids Size 5B Bobbin Coil

Performance Specifications

Stroke	Holding Torque ² (lb-in)	Starting Torque (lb-in) ¹ @ 20°C Maximum Duty Cycle				
		100%	50%	25%	10%	5%
25°	4.0	1.8	3.5	5.8	8.3	10.0
35°	*	0.9	2.1	4.1	6.9	8.3
45°	3.0	0.7	1.7	3.2	5.0	6.0
67½°	*	0.5	1.1	2.0	3.3	4.0
95°	2.0	0.2	0.4	0.9	1.6	1.9

All data is at 20°C coil temperature. Force (torque) outputs degrade with elevated temperatures.

- ¹ Gross starting torques are shown. For net available starting torque, subtract return spring torque of 0.25 lb.-in. ±20%.
- ² Holding torque is shown at the stabilized temperature of 105°C and continuous duty.
- * Consult factory.

ROTARY Solenoids

All catalog products manufactured after April 1, 2006 are RoHS Compliant

How to Order

- Using the Performance Chart to the left, select one of the five columns which provides the appropriate duty cycle for your application. Reading down this column locate the torque for the stroke you need. For net available starting torque, subtract return spring torque of 0.25 lb.-in. ±20% (if torque is insufficient go to next larger solenoid size).
- Use the chart below to select the model number corresponding to your desired design, stroke and direction of rotation (as viewed from armature end, opposite mounting studs).
- Using the Specification Chart to the right, select the same duty cycle column. Follow down the column into the VDC ratings. Select the voltage which most closely matches your supply voltage. Read across to the left to select the coil awg suffix.
- Replace the last two digits of the model number (XX) with the coil awg number to complete the part number.

Please see www.ledex.com (click on Stock Products tab) for our list of stock products available through our North American distributors.

- Armature cover
- Base end shaft
- Return spring

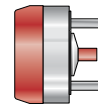

Stroke/Direction*	Nom. Axial Stroke	
25° CW	0.042"	810-380-5XX
25° CCW	0.042"	810-385-5XX
35° CW	0.045"	810-381-5XX
35° CCW	0.045"	810-386-5XX
45° CW	0.045"	810-382-5XX
45° CCW	0.045"	810-387-5XX
67½° CW	0.050"	810-383-5XX
67½° CCW	0.050"	810-388-5XX
95° CW	0.055"	810-384-5XX
95° CCW	0.055"	810-389-5XX

* Direction of rotation (cw – clockwise or ccw – counterclockwise) is viewed from the armature end of the solenoid opposite the mounting studs.

Note: The XX in the part number suffix must be filled in with the awg of your choice.

Ledex® Rotary Solenoids Size 5B Bobbin Coil

Coil Specifications

Maximum Duty Cycle	100%	50%	25%	10%	5%
Maximum ON Time (sec) when pulsed continuously ¹	∞	100	36	10	3.5
Maximum ON Time (sec) for single pulse ²	∞	160	44	13	4.6
Watts (@ 20°C)	21	42	84	210	420
Ampere Turns (@ 20°C)	890	1250	1760	2800	3987

Coil Data

awg (0XX) ³	Resistance (@20°C)	# Turns ⁴	VDC (Nom)	VDC (Nom)	VDC (Nom)	VDC (Nom)	VDC (Nom)
23	2.01	294	6.1	8.5	12.0	19.1	27.0
24	3.15	364	7.7	10.8	15.2	24.0	35.0
25	4.88	448	9.7	13.6	19.2	31.0	43.0
26	7.72	564	12.2	17.1	24.0	38.0	55.0
27	10.90	648	15.0	21.0	30.0	47.0	67.0
28	18.20	836	19.4	27.0	38.0	61.0	87.0
29	30.40	1105	25.0	34.0	48.0	77.0	110.0
30	42.50	1248	30.0	43.0	60.0	95.0	136.0
31	69.00	1590	39.0	54.0	76.0	122.0	173.0
32	107.00	2006	48.0	67.0	94.0	149.0	213.0
33	169.00	2470	61.0	86.0	120.0	192.0	273.0

General Specifications

Dielectric Strength	23 awg, 1000 VRMS; 24-33 awg, 1200 VRMS
Recommended Minimum Heat Sink	Maximum watts dissipated by solenoid are based on an unrestricted flow of air at 20°C, with solenoid mounted on the equivalent of an aluminum plate measuring 7½" square by ⅛" thick.
Coil Resistance	±10% tolerance
Starting Torque	Gross torque values are shown. For net starting torque, subtract return spring torque
Return Spring Torque	0.25 pound-inches ±20%
Weight	10 oz (283.5 gm)
Dimensions	See page D33

- Continuously pulsed at stated watts and duty cycle.
- Single pulse at stated watts (with coil at ambient room temperature 20°C).
- Other coil awg sizes available, consult factory.
- Reference number of turns.

All specifications subject to change without notice.

- No shafts
- 3 tapped holes
- Return spring

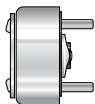

810-640-5XX
810-645-5XX
810-641-5XX
810-646-5XX
810-642-5XX
810-647-5XX
810-643-5XX
810-648-5XX
810-644-5XX
810-649-5XX

- Armature end shaft
- 3 tapped holes
- Return spring

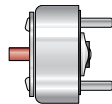

810-490-5XX
810-495-5XX
810-491-5XX
810-496-5XX
810-492-5XX
810-497-5XX
810-493-5XX
810-498-5XX
810-494-5XX
810-499-5XX

- Base end shaft
- 3 tapped holes
- Return spring

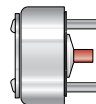

810-360-5XX
810-365-5XX
810-361-5XX
810-366-5XX
810-362-5XX
810-367-5XX
810-363-5XX
810-368-5XX
810-364-5XX
810-369-5XX

- Double shaft
- 3 tapped holes
- Return spring

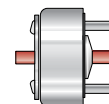

810-280-5XX
810-285-5XX
810-281-5XX
810-286-5XX
810-282-5XX
810-287-5XX
810-283-5XX
810-288-5XX
810-284-5XX
810-289-5XX

Ledex® Rotary Solenoids Size 5S Precision Standard Coil

ROTARY Solenoids

Performance Specifications

Stroke	Holding Torque ² (lb-in)	Starting Torque (lb-in) ¹ @ 20°C Maximum Duty Cycle				
		100%	50%	25%	10%	5%
25°	5.0	1.9	4.1	7.3	12.1	13.2
35°	*	1.2	2.6	4.5	7.8	9.2
45°	3.0	0.7	1.7	3.4	6.3	6.9
55°	*	*	*	*	*	*
67½°	*	0.5	1.2	2.2	3.9	4.9
75°	*	*	*	*	*	*
95°	2.0	0.2	0.5	1.0	1.9	2.6
110°	*	*	*	*	*	*

All data is at 20°C coil temperature. Force (torque) outputs degrade with elevated temperatures.

¹ Gross starting torques are shown. For net available starting torque, subtract return spring torque of 0.25 lb.-in. ±20%.

² Holding torque is shown at the stabilized temperature of 105°C and continuous duty.

* Consult factory.

How to Order

- Using the Performance Chart to the left, select one of the five columns which provides the appropriate duty cycle for your application. Reading down this column locate the torque for the stroke you need. For net available starting torque, subtract return spring torque of 0.25 lb.-in. ±20% (if torque is insufficient go to next larger solenoid size).
- Use the chart below to select the model number corresponding to your desired design, stroke and direction of rotation (as viewed from armature end, opposite mounting studs).
- Using the Specification Chart to the right, select the same duty cycle column. Follow down the column into the VDC ratings. Select the voltage which most closely matches your supply voltage. Read across to the left to select the coil awg suffix.
- Replace the last two digits of the model number (XX) with the coil awg number to complete the part number.

Please see www.ledex.com (click on Stock Products tab) for our list of stock products available through our North American distributors.

All catalog products manufactured after April 1, 2006 are RoHS Compliant

- Armature cover
- Armature end shaft
- Return spring

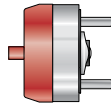

- Armature cover
- Base end shaft
- Return spring

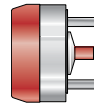

- Armature cover
- Double shaft
- Return spring

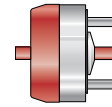

Stroke/ Direction*	Nom. Axial Stroke	Standard		Long Life		Standard		Long Life	
		Standard	Long Life	Standard	Long Life	Standard	Long Life		
25° CW	0.042"	H-2480-OXX	L-2480-OXX	H-2073-OXX	L-2073-OXX	H-15165-OXX	L-15165-OXX	H-3421-OXX	L-3421-OXX
25° CCW	0.042"	H-2657-OXX	L-2657-OXX	H-2593-OXX	L-2593-OXX	H-2874-OXX	L-2874-OXX	H-1423-OXX	L-1423-OXX
35° CW	0.045"	H-2658-OXX	L-2658-OXX	H-2681-OXX	L-2681-OXX	H-1345-OXX	L-1345-OXX	H-15072-OXX	L-15072-OXX
35° CCW	0.045"	H-3384-OXX	L-3384-OXX	H-2479-OXX	L-2479-OXX	H-15315-OXX	L-15315-OXX	H-15316-OXX	L-15316-OXX
45° CW	0.045"	H-2527-OXX	L-2527-OXX	H-2383-OXX	L-2383-OXX	H-3375-OXX	L-3375-OXX	H-3377-OXX	L-3377-OXX
45° CCW	0.045"	H-1125-OXX	L-1125-OXX	H-2300-OXX	L-2300-OXX	H-15312-OXX	L-15312-OXX	H-15317-OXX	L-15317-OXX
55° CW	0.048"	H-15305-OXX	—	H-15310-OXX	—	H-15318-OXX	L-15318-OXX	H-15319-OXX	L-15319-OXX
55° CCW	0.048"	H-15306-OXX	—	H-15311-OXX	—	—	—	—	—
67½° CW	0.050"	H-1390-OXX	—	H-2349-OXX	—	—	—	—	—
67½° CCW	0.050"	H-3385-OXX	—	H-2262-OXX	—	—	—	—	—
75° CCW	0.050"	H-15307-OXX	—	H-15312-OXX	—	—	—	—	—
95° CW	0.055"	H-2010-OXX	—	H-2382-OXX	—	—	—	—	—
95° CCW	0.055"	H-1248-OXX	—	H-2747-OXX	—	—	—	—	—
110° CW	0.055"	H-15308-OXX	—	H-15313-OXX	—	—	—	—	—
110° CCW	0.055"	H-15309-OXX	—	H-15314-OXX	—	—	—	—	—

* Direction of rotation (cw – clockwise or ccw – counterclockwise) is viewed from the armature end of the solenoid opposite the mounting studs.

Note: The XX in the part number suffix must be filled in with the awg of your choice.

Ledex® Rotary Solenoids Size 5S Precision Standard Coil

Coil Specifications

Maximum Duty Cycle	100%	50%	25%	10%	5%
Maximum ON Time (sec) when pulsed continuously ¹	∞	100	36	10	3.5
Maximum ON Time (sec) for single pulse ²	∞	160	44	13	4.6
Watts (@ 20°C)	21	42	84	210	420
Ampere Turns (@ 20°C)	860	1220	1720	2730	3853

Coil Data

awg (0XX) ³	Resistance (@20°C)	# Turns ⁴	VDC (Nom)	VDC (Nom)	VDC (Nom)	VDC (Nom)	VDC (Nom)
23	2.03	288	6.1	8.6	12.1	19.2	27.0
24	3.20	360	7.6	10.8	15.3	24.0	34.0
25	4.91	440	9.6	13.6	19.2	31.0	43.0
26	7.72	550	12.1	17.1	24.0	38.0	54.0
27	11.12	636	15.0	21.0	30.0	48.0	67.0
28	18.79	840	19.2	27.0	39.0	61.0	86.0
29	30.48	1088	24.0	34.0	48.0	77.0	108.0
30	44.86	1275	30.0	43.0	61.0	96.0	136.0
31	70.90	1596	38.0	54.0	76.0	121.0	171.0
32	109.00	1974	47.0	67.0	95.0	150.0	212.0
33	175.00	2496	60.0	86.0	121.0	192.0	271.0

General Specifications

Dielectric Strength	23 awg, 1000 VRMS; 24-33 awg, 1200 VRMS
Recommended Minimum Heat Sink	Maximum watts dissipated by solenoid are based on an unrestricted flow of air at 20°C, with solenoid mounted on the equivalent of an aluminum plate measuring 7 1/2" square by 1/8" thick.
Coil Resistance	±5% tolerance
Starting Torque	Gross torque values are shown. For net starting torque, subtract return spring torque
Return Spring Torque	0.25 pound-inches ±20%
Weight	9.0 oz (255.2 gms)
Dimensions	See page D34

- Continuously pulsed at stated watts and duty cycle.
- Single pulse at stated watts (with coil at ambient room temperature 20°C).
- Other coil awg sizes available, consult factory.
- Reference number of turns.

All specifications subject to change without notice.

- No shafts
- 3 tapped holes
- Return spring

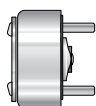

- Armature end shaft
- 3 tapped holes
- Return spring

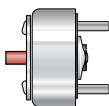

- Base end shaft
- 3 tapped holes
- Return spring

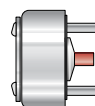

- Double shaft
- 3 tapped holes
- Return spring

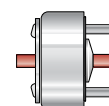

ROTARY Solenoids

Standard	Long Life	Standard	Long Life	Standard	Long Life	Standard	Long Life
H-1082-0XX	L-1082-0XX	H-2668-0XX	L-2668-0XX	H-2050-0XX	L-2050-0XX	H-2414-0XX	L-2414-0XX
H-2434-0XX	L-2434-0XX	H-2669-0XX	L-2669-0XX	H-3189-0XX	L-3189-0XX	H-2708-0XX	L-2708-0XX
H-2560-0XX	L-2560-0XX	H-3151-0XX	L-3151-0XX	H-2186-0XX	L-2186-0XX	H-2875-0XX	L-2875-0XX
H-1087-0XX	L-1087-0XX	H-1431-0XX	L-1431-0XX	H-3276-0XX	L-3276-0XX	H-2016-0XX	L-2016-0XX
H-2397-0XX	L-2397-0XX	H-2555-0XX	L-2555-0XX	H-2136-0XX	L-2136-0XX	H-3397-0XX	L-3397-0XX
H-2185-0XX	L-2185-0XX	H-3238-0XX	L-3238-0XX	H-1308-0XX	L-1308-0XX	H-2845-0XX	L-2845-0XX
H-15320-0XX	—	H-15325-0XX	—	H-15330-0XX	—	H-15335-0XX	—
H-15321-0XX	—	H-15326-0XX	—	H-15331-0XX	—	H-15336-0XX	—
H-2522-0XX	—	H-2075-0XX	—	H-1020-0XX	—	H-3399-0XX	—
H-2902-0XX	—	H-3249-0XX	—	H-15055-0XX	—	H-3400-0XX	—
H-15322-0XX	—	H-15327-0XX	—	H-15332-0XX	—	H-15337-0XX	—
H-2714-0XX	—	H-2074-0XX	—	H-2957-0XX	—	H-1155-0XX	—
H-2296-0XX	—	H-2150-0XX	—	H-1307-0XX	—	H-1154-0XX	—
H-15323-0XX	—	H-15328-0XX	—	H-15333-0XX	—	H-15338-0XX	—
H-15324-0XX	—	H-15329-0XX	—	H-15334-0XX	—	H-15339-0XX	—

Ledex® Rotary Solenoids Size 6S Precision Standard Coil

Performance Specifications

Stroke	Holding Torque ² (lb-in)	Starting Torque (lb-in) ¹ @ 20°C Maximum Duty Cycle				
		100%	50%	25%	10%	5%
25°	9.0	4.6	8.9	16.2	27.8	30.6
35°	*	3.4	6.5	12.0	18.6	20.5
45°	6.0	1.7	3.5	6.5	11.0	12.1
55°	*	*	*	*	*	*
67½°	*	1.6	3.1	5.6	8.8	9.7
95°	3.0	0.9	1.7	3.3	5.2	5.7
110°	*	*	*	*	*	*

All data is at 20°C coil temperature. Force (torque) outputs degrade with elevated temperatures.

¹ Gross starting torques are shown. For net available starting torque, subtract return spring torque of 0.50 lb.-in. ±20%.

² Holding torque is shown at the stabilized temperature of 105°C and continuous duty.

* Consult factory.

How to Order

- Using the Performance Chart to the left, select one of the five columns which provides the appropriate duty cycle for your application. Reading down this column locate the torque for the stroke you need. For net available starting torque, subtract return spring torque of 0.50 lb.-in. ±20% (if torque is insufficient go to next larger solenoid size).
- Use the chart below to select the model number corresponding to your desired design, stroke and direction of rotation (as viewed from armature end, opposite mounting studs).
- Using the Specification Chart to the right, select the same duty cycle column. Follow down the column into the VDC ratings. Select the voltage which most closely matches your supply voltage. Read across to the left to select the coil awg suffix.
- Replace the last two digits of the model number (XX) with the coil awg number to complete the part number.

Please see www.ledex.com (click on Stock Products tab) for our list of stock products available through our North American distributors.

All catalog products manufactured after April 1, 2006 are RoHS Compliant

- Armature cover
- Armature end shaft
- Return spring

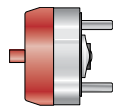

- Armature cover
- Base end shaft
- Return spring

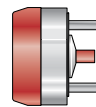

- Armature cover
- Double shaft
- Return spring

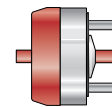

Stroke/ Direction*	Nom. Axial Stroke	Standard		Long Life		Standard		Long Life	
		Standard	Long Life	Standard	Long Life	Standard	Long Life		
25° CW	0.055"	H-1202-0XX	L-1202-0XX	H-2484-0XX	L-2484-0XX	H-3376-0XX	L-3376-0XX	H-15036-0XX	L-15036-0XX
25° CCW	0.055"	H-1005-0XX	L-1005-0XX	H-2485-0XX	L-2485-0XX	H-15036-0XX	L-15036-0XX		
35° CW	0.058"	H-15023-0XX	L-15023-0XX	H-2916-0XX	L-2916-0XX	H-3365-0XX	L-3365-0XX		
35° CCW	0.058"	H-15024-0XX	L-15024-0XX	H-2942-0XX	L-2942-0XX	H-2964-0XX	L-2964-0XX		
45° CW	0.060"	H-3136-0XX	L-3136-0XX	H-2817-0XX	L-2817-0XX	H-15066-0XX	L-15066-0XX		
45° CCW	0.060"	H-2510-0XX	L-2510-0XX	H-2698-0XX	L-2698-0XX	H-3308-0XX	L-3308-0XX		
55° CW	0.060"	H-15400-0XX	—	H-15403-0XX	—	H-15406-0XX	—		
67½° CW	0.060"	H-1182-0XX	—	H-2181-0XX	—	H-1483-0XX	—		
67½° CCW	0.060"	H-2293-0XX	—	H-2671-0XX	—	H-1481-0XX	—		
95° CW	0.060"	H-3230-0XX	—	H-2643-0XX	—	H-1078-0XX	—		
95° CCW	0.060"	H-1351-0XX	—	H-2223-0XX	—	H-15095-0XX	—		
110° CW	0.066"	H-15401-0XX	—	H-15404-0XX	—	H-15407-0XX	—		
110° CCW	0.066"	H-15402-0XX	—	H-15405-0XX	—	H-15408-0XX	—		

* Direction of rotation (cw – clockwise or ccw – counterclockwise) is viewed from the armature end of the solenoid opposite the mounting studs.

Note: The XX in the part number suffix must be filled in with the awg of your choice.

Ledex® Rotary Solenoids Size 6S Precision Standard Coil

Coil Specifications

Maximum Duty Cycle	100%	50%	25%	10%	5%
Maximum ON Time (sec) when pulsed continuously ¹	∞	87	36	13	4.6
Maximum ON Time (sec) for single pulse ²	∞	140	44	16	5.7
Watts (@ 20°C)	32	64	128	320	640
Ampere Turns (@ 20°C)	1240	1760	2490	3920	5555

Coil Data

awg (0XX) ³	Resistance (@20°C)	# Turns ⁴	VDC (Nom)	VDC (Nom)	VDC (Nom)	VDC (Nom)	VDC (Nom)
23	3.59	432	10.3	14.6	21.0	33.0	46.0
24	5.24	500	13.0	18.4	26.0	41.0	58.0
25	9.51	708	16.7	24.0	33.0	53.0	75.0
26	14.44	858	21.0	30.0	42.0	66.0	94.0
27	23.69	1110	27.0	38.0	53.0	84.0	119.0
28	38.27	1411	34.0	48.0	68.0	106.0	151.0
29	54.62	1638	41.0	59.0	83.0	131.0	185.0
30	93.67	2184	53.0	76.0	107.0	168.0	238.0
31	143.00	2645	67.0	95.0	134.0	211.0	299.0
32	223.00	3328	83.0	118.0	167.0	262.0	372.0
33	338.00	4004	105.0	149.0	210.0	331.0	469.0

General Specifications

Dielectric Strength	23-31 awg, 1200 VRMS; 32-33 awg, 1500 VRMS
Recommended Minimum Heat Sink	Maximum watts dissipated by solenoid are based on an unrestricted flow of air at 20°C, with solenoid mounted on the equivalent of an aluminum plate measuring 12 ³ / ₈ " square by 1 ¹ / ₈ " thick.
Coil Resistance	±5% tolerance
Starting Torque	Gross torque values are shown. For net starting torque, subtract return spring torque
Return Spring Torque	0.5 pound-inches ±20%
Weight	1 lb 2 oz (510.3 gms)
Dimensions	See page D35

- Continuously pulsed at stated watts and duty cycle.
- Single pulse at stated watts (with coil at ambient room temperature 20°C).
- Other coil awg sizes available, consult factory.
- Reference number of turns.

All specifications subject to change without notice.

- No shafts
- 3 tapped holes
- Return spring

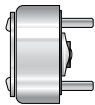

- Armature end shaft
- 3 tapped holes
- Return spring

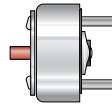

- Base end shaft
- 3 tapped holes
- Return spring

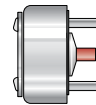

- Double shaft
- 3 tapped holes
- Return spring

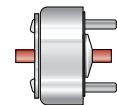

Standard	Long Life	Standard	Long Life	Standard	Long Life	Standard	Long Life
H-2481-0XX	L-2481-0XX	H-3055-0XX	L-3055-0XX	H-2184-0XX	L-2184-0XX	H-15067-0XX	L-15067-0XX
H-1002-0XX	L-1002-0XX	H-1291-0XX	L-1291-0XX	H-1306-0XX	L-1306-0XX	H-15123-0XX	L-15123-0XX
H-2861-0XX	L-2861-0XX	H-1230-0XX	L-1230-0XX	H-15417-0XX	L-15417-0XX	H-2057-0XX	L-2057-0XX
H-2269-0XX	L-2269-0XX	H-15412-0XX	L-15412-0XX	H-15418-0XX	L-15418-0XX	H-15136-0XX	L-15136-0XX
H-1112-0XX	L-1112-0XX	H-15013-0XX	L-15013-0XX	H-1311-0XX	L-1311-0XX	H-15064-0XX	L-15064-0XX
H-2328-0XX	L-2328-0XX	H-3208-0XX	L-3208-0XX	H-1286-0XX	L-1286-0XX	H-15424-0XX	L-15424-0XX
H-15409-0XX	—	H-15413-0XX	—	H-15419-0XX	—	H-15425-0XX	—
H-2404-0XX	—	H-3264-0XX	—	H-15420-0XX	—	H-15426-0XX	—
H-2661-0XX	—	H-15414-0XX	—	H-15421-0XX	—	H-15427-0XX	—
H-2072-0XX	—	H-2826-0XX	—	H-1313-0XX	—	H-2001-0XX	—
H-2071-0XX	—	H-3002-0XX	—	H-2936-0XX	—	H-15030-0XX	—
H-15410-0XX	—	H-15415-0XX	—	H-15422-0XX	—	H-15428-0XX	—
H-15411-0XX	—	H-15416-0XX	—	H-15423-0XX	—	H-15429-0XX	—

Ledex® Rotary Solenoids Size 7S Precision Standard Coil

Performance Specifications

Stroke	Holding Torque ² (lb-in)	Starting Torque (lb-in) ¹ @ 20°C Maximum Duty Cycle				
		100%	50%	25%	10%	5%
25°	20.0	11.0	23.8	33.2	42.4	46.6
35°	*	6.0	12.0	22.0	38.0	42.0
45°	13.0	5.0	8.8	16.4	29.8	32.8
55°	*	*	*	*	*	*
67½°	*	2.5	5.1	9.8	17.5	19.3
95°	6.0	1.5	3.5	6.4	10.5	11.6

All data is at 20°C coil temperature. Force (torque) outputs degrade with elevated temperatures.

- Gross starting torques are shown. For net available starting torque, subtract return spring torque of 0.75 lb.-in. ±20%.
- Holding torque is shown at the stabilized temperature of 105°C and continuous duty.
- Consult factory.

How to Order

- Using the Performance Chart to the left, select one of the five columns which provides the appropriate duty cycle for your application. Reading down this column locate the torque for the stroke you need. For net available starting torque, subtract return spring torque of 0.75 lb.-in. ±20% (if torque is insufficient go to next larger solenoid size).
- Use the chart below to select the model number corresponding to your desired design, stroke and direction of rotation (as viewed from armature end, opposite mounting studs).
- Using the Specification Chart to the right, select the same duty cycle column. Follow down the column into the VDC ratings. Select the voltage which most closely matches your supply voltage. Read across to the left to select the coil awg suffix.
- Replace the last two digits of the model number (XX) with the coil awg number to complete the part number.

Please see www.ledex.com (click on Stock Products tab) for our list of stock products available through our North American distributors.

All catalog products manufactured after April 1, 2006 are RoHS Compliant

- Armature cover
- Armature end shaft
- Return spring

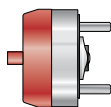

- Armature cover
- Base end shaft
- Return spring

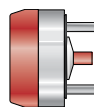

- Armature cover
- Double shaft
- Return spring

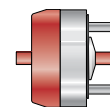

Stroke/ Direction*	Nom. Axial Stroke	Standard		Long Life		Standard		Long Life	
		Standard	Long Life	Standard	Long Life	Standard	Long Life		
25° CW	0.075"	H-3057-0XX	L-3057-0XX	H-2477-0XX	L-2477-0XX	H-2309-0XX	L-2309-0XX	H-15009-0XX	L-15009-0XX
25° CCW	0.075"	H-1354-0XX	L-1354-0XX	H-2592-0XX	L-2592-0XX	H-15009-0XX	L-15009-0XX	H-15009-0XX	L-15009-0XX
35° CW	0.078"	H-15076-0XX	L-15076-0XX	H-2355-0XX	L-2355-0XX	H-3406-0XX	L-3406-0XX	H-15103-0XX	L-15103-0XX
35° CCW	0.078"	H-15485-0XX	L-15485-0XX	H-2323-0XX	L-2323-0XX	H-15103-0XX	L-15103-0XX	H-15103-0XX	L-15103-0XX
45° CW	0.080"	H-1355-0XX	L-1355-0XX	H-3070-0XX	L-3070-0XX	H-1428-0XX	L-1428-0XX	H-15054-0XX	L-15054-0XX
45° CCW	0.080"	H-1356-0XX	L-1356-0XX	H-3148-0XX	L-3148-0XX	H-15054-0XX	L-15054-0XX	H-15054-0XX	L-15054-0XX
55° CW	0.080"	H-15486-0XX	—	H-15487-0XX	—	H-15488-0XX	—	H-15488-0XX	—
67½° CW	0.080"	H-2809-0XX	—	H-2400-0XX	—	H-1480-0XX	—	H-1480-0XX	—
67½° CCW	0.080"	H-15061-0XX	—	H-2303-0XX	—	H-1484-0XX	—	H-1484-0XX	—
95° CW	0.088"	H-1178-0XX	—	H-3069-0XX	—	H-1334-0XX	—	H-1334-0XX	—
95° CCW	0.088"	H-1357-0XX	—	H-2858-0XX	—	H-15121-0XX	—	H-15121-0XX	—

* Direction of rotation (cw – clockwise or ccw – counterclockwise) is viewed from the armature end of the solenoid opposite the mounting studs.

Note: The XX in the part number suffix must be filled in with the awg of your choice.

Ledex® Rotary Solenoids Size 7S Precision Standard Coil

Coil Specifications

Maximum Duty Cycle	100%	50%	25%	10%	5%
Maximum ON Time (sec) when pulsed continuously ¹	∞	80	38	16	5.7
Maximum ON Time (sec) for single pulse ²	∞	138	50	18	6.4
Watts (@ 20°C)	35	70	140	350	700
Ampere Turns (@ 20°C)	1570	2230	3150	5000	7034

Coil Data

awg (0XX) ³	Resistance (@20°C)	# Turns ⁴	VDC (Nom)	VDC (Nom)	VDC (Nom)	VDC (Nom)	VDC (Nom)
23	8.09	780	16.3	23.0	33.0	52.0	73.0
24	12.34	949	21.0	29.0	41.0	65.0	92.0
25	18.62	1148	26.0	37.0	52.0	83.0	116.0
26	30.84	1472	33.0	47.0	66.0	105.0	147.0
27	48.77	1854	41.0	59.0	83.0	132.0	185.0
28	81.14	2436	52.0	74.0	105.0	167.0	234.0
29	121.0	2944	65.0	92.0	130.0	206.0	290.0
30	190.0	3650	82.0	116.0	164.0	261.0	367.0
31	275.0	4175	103.0	147.0	208.0	329.0	463.0
32	440.0	5292	130.0	169.0	239.0	380.0	—
33	715.0	6650	158.0	223.0	316.0	—	—

General Specifications

Dielectric Strength	23-29 awg, 1200 VRMS; 30-33 awg, 1500 VRMS
Recommended Minimum Heat Sink	Maximum watts dissipated by solenoid are based on an unrestricted flow of air at 20°C, with solenoid mounted on the equivalent of an aluminum plate measuring 15 $\frac{1}{8}$ " square by $\frac{1}{8}$ " thick.
Coil Resistance	23-30 awg, $\pm 5\%$ tolerance; 31-33 awg, $\pm 10\%$ tolerance
Starting Torque	Gross torque values are shown. For net starting torque, subtract return spring torque
Return Spring Torque	0.75 pound-inches $\pm 20\%$
Weight	2.25 lb (1.020 kgs)
Dimensions	See page D36

- Continuously pulsed at stated watts and duty cycle.
- Single pulse at stated watts (with coil at ambient room temperature 20°C).
- Other coil awg sizes available, consult factory.
- Reference number of turns.

All specifications subject to change without notice.

- No shafts
- 3 tapped holes
- Return spring

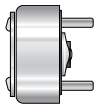

- Armature end shaft
- 3 tapped holes
- Return spring

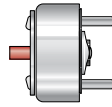

- Base end shaft
- 3 tapped holes
- Return spring

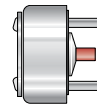

- Double shaft
- 3 tapped holes
- Return spring

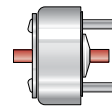

ROTARY Solenoids

Standard	Long Life	Standard	Long Life	Standard	Long Life	Standard	Long Life
H-1352-0XX	L-1352-0XX	H-15491-0XX	L-15491-0XX	H-2490-0XX	L-2490-0XX	H-2415-0XX	L-2415-0XX
H-2590-0XX	L-2590-0XX	H-1197-0XX	L-1197-0XX	H-3362-0XX	L-3362-0XX	H-15116-0XX	L-15116-0XX
H-2388-0XX	L-2388-0XX	H-15492-0XX	L-15492-0XX	H-15498-0XX	L-15498-0XX	H-15134-0XX	L-15134-0XX
H-15616-0XX	L-15616-0XX	H-15493-0XX	L-15493-0XX	H-1467-0XX	L-1467-0XX	H-15137-0XX	L-15137-0XX
H-2950-0XX	L-2950-0XX	H-3007-0XX	L-3007-0XX	H-1312-0XX	L-1312-0XX	H-15502-0XX	L-15502-0XX
H-3096-0XX	L-3096-0XX	H-15014-0XX	L-15014-0XX	H-1317-0XX	L-1317-0XX	H-15503-0XX	L-15503-0XX
H-15490-0XX	—	H-15494-0XX	—	H-15499-0XX	—	H-15614-0XX	—
H-3350-0XX	—	H-15495-0XX	—	H-15500-0XX	—	H-15504-0XX	—
H-15158-0XX	—	H-15496-0XX	—	H-15501-0XX	—	H-15505-0XX	—
H-1353-0XX	—	H-15104-0XX	—	H-2869-0XX	—	H-3037-0XX	—
H-3289-0XX	—	H-15497-0XX	—	H-1316-0XX	—	H-15506-0XX	—

Ledex[®] Rotary Solenoids 1E Dimensions

Inches (mm)

Armature Cover Configuration — Armature End Shaft

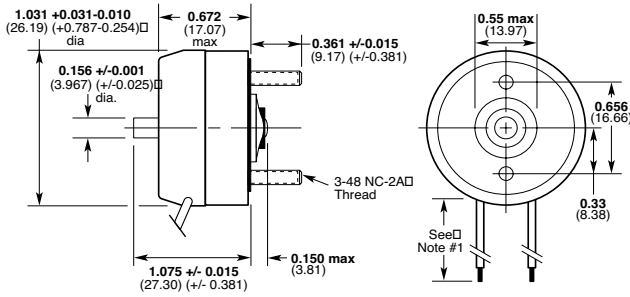

Armature Cover Configuration — Base End Shaft

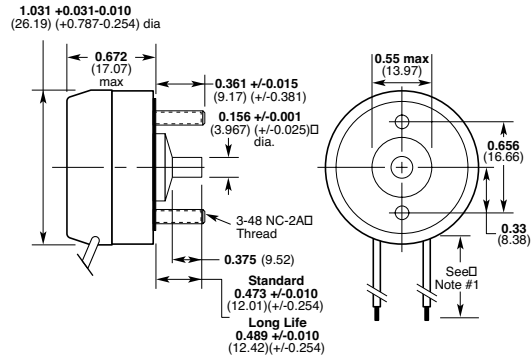

Armature Cover Configuration — Double Shaft

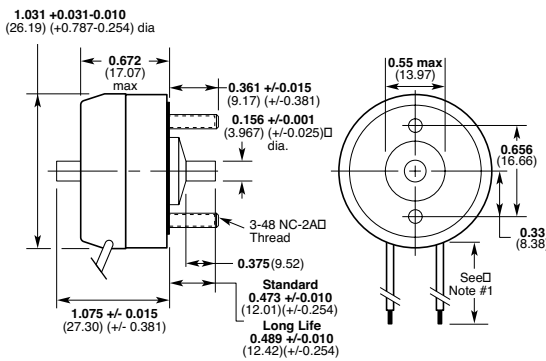

Notes:

- 1) All configurations have 10" (254 mm) minimum leads, 24 awg, PVC insulation.
- 2) For electrical specs and performance charts, see pages D10-D11.

All specifications subject to change without notice.

ROTARY Solenoids

No Shaft

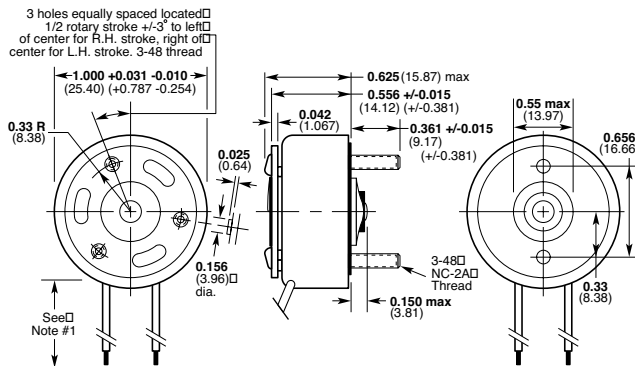

Base End Shaft

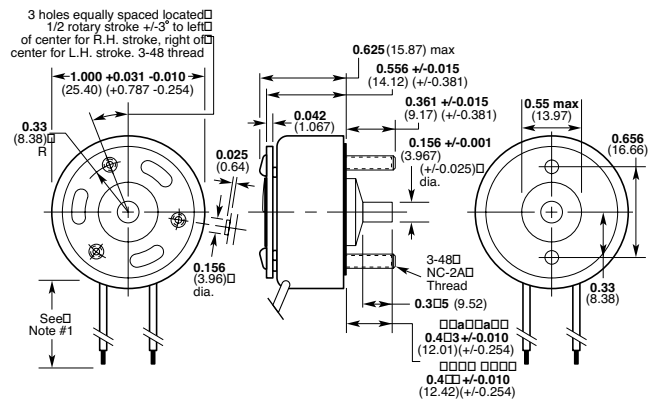

Armature End Shaft

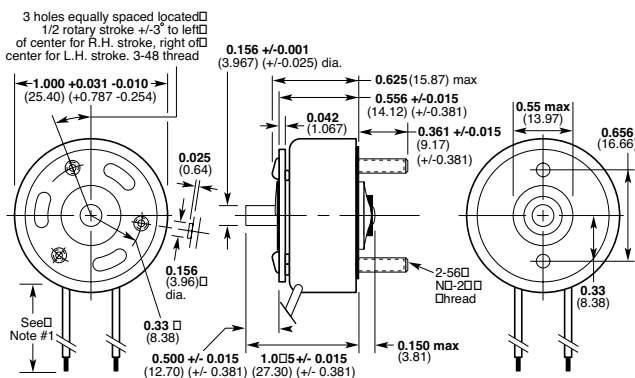

Double Shaft

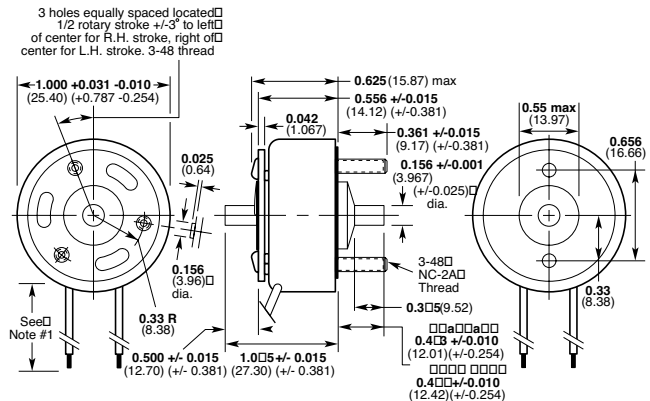

Ledex® Rotary Solenoids 2E Dimensions

Inches (mm)

Armature Cover Configuration — Armature End Shaft

Armature Cover Configuration — Base End Shaft

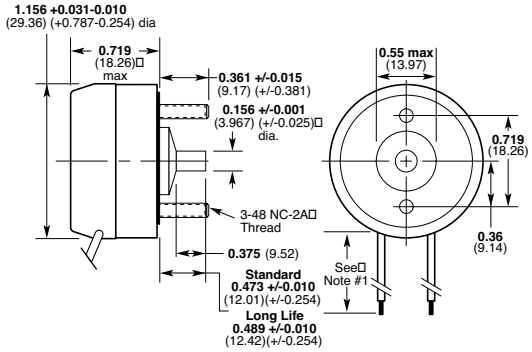
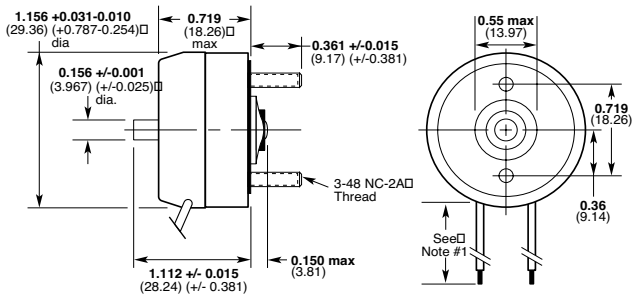

Armature Cover Configuration — Double Shaft

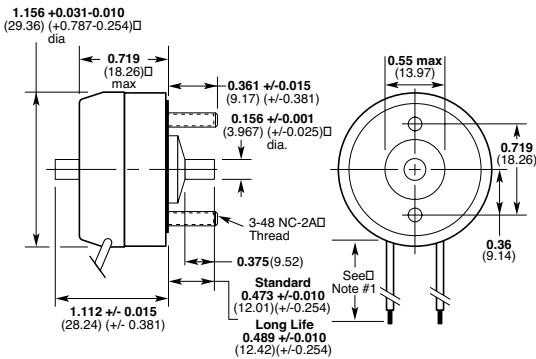

Notes:

- 1) All configurations have 10" (254 mm) minimum leads, 24 awg. PVC insulation.
- 2) For electrical specs and performance charts, see pages D12-D13.

All specifications subject to change without notice.

No Shaft

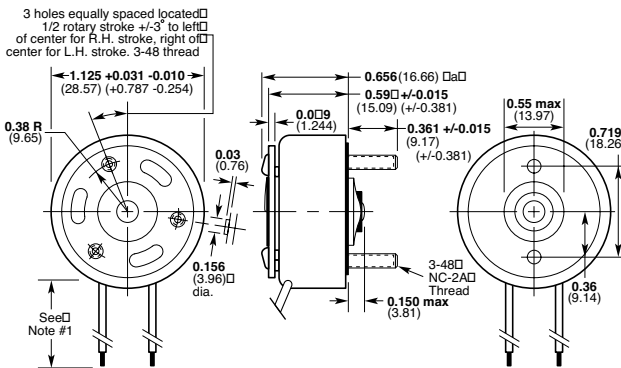

Base End Shaft

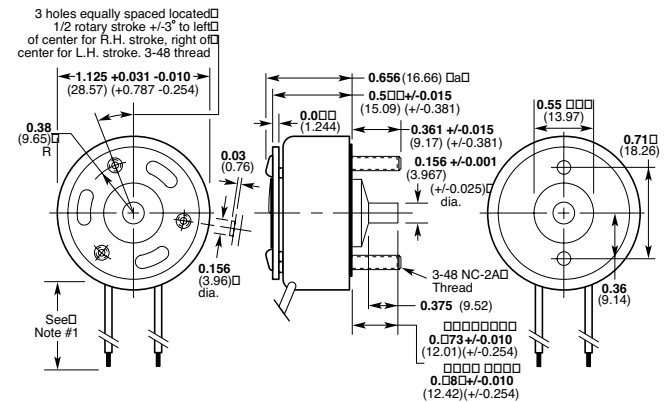

Armature End Shaft

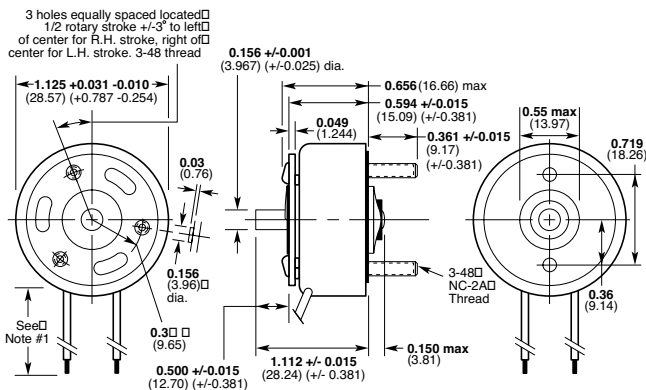

Double Shaft

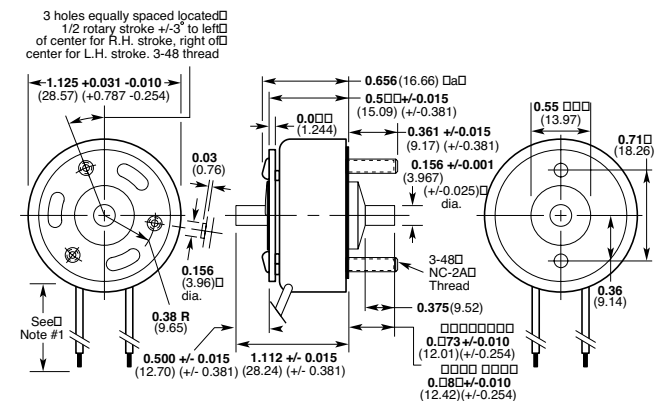

ROTARY Solenoids

Ledex[®] Rotary Solenoids 3B Dimensions

Inches (mm)

Armature Cover Configuration — Base End Shaft

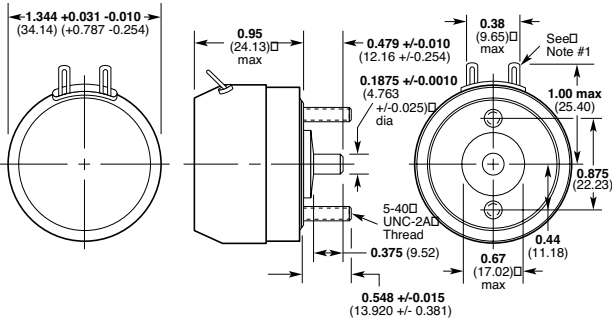

Notes:

- 1) All configurations have solder lug terminals. 0.093" (2.36) wide x 0.018 (0.457) thick.
- 2) For electrical specs and performance charts, see pages D14-D15.

All specifications subject to change without notice.

ROTARY Solenoids

No Shaft

3 holes equally spaced located 1/2 rotary stroke +/- 3° to left of center for R.H. stroke, right of center for L.H. stroke. 3-48 thread

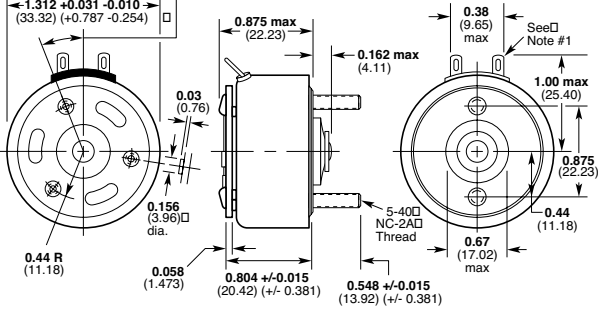

Base End Shaft

3 holes equally spaced located 1/2 rotary stroke +/- 3° to left of center for R.H. stroke, right of center for L.H. stroke. 3-48 thread

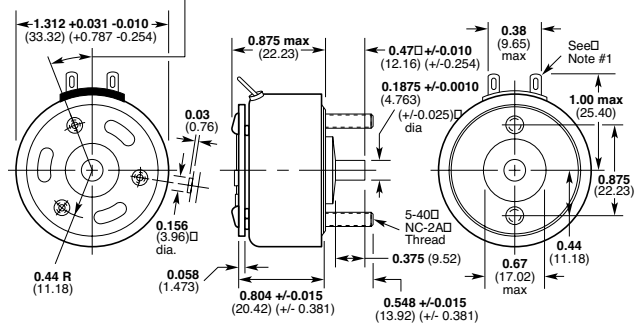

Armature End Shaft

3 holes equally spaced located 1/2 rotary stroke +/- 3° to left of center for R.H. stroke, right of center for L.H. stroke. 3-48 thread

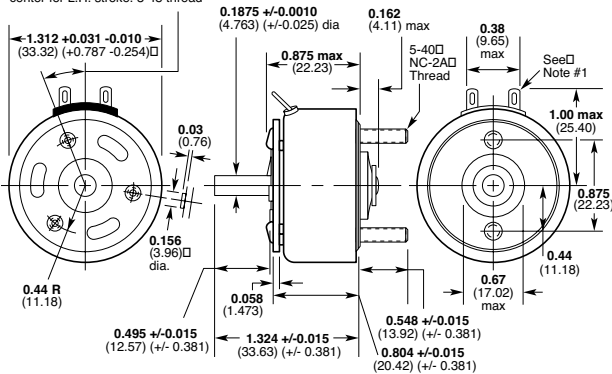

Double Shaft

3 holes equally spaced located 1/2 rotary stroke +/- 3° to left of center for R.H. stroke, right of center for L.H. stroke. 3-48 thread

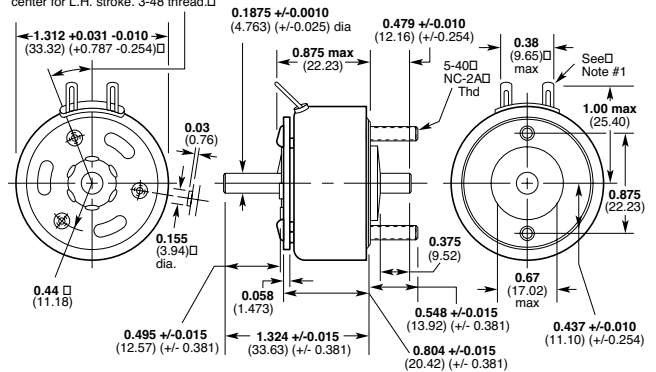

Ledex® Rotary Solenoids 3E Dimensions

Inches (mm)

Armature Cover Configuration — Armature End Shaft

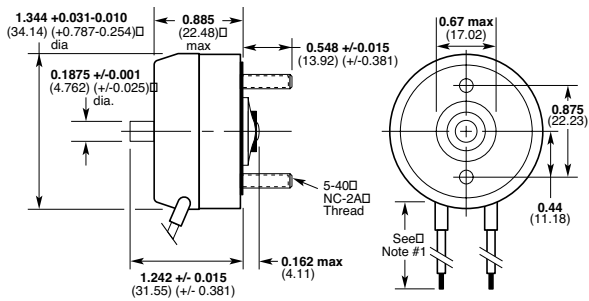

Armature Cover Configuration — Base End Shaft

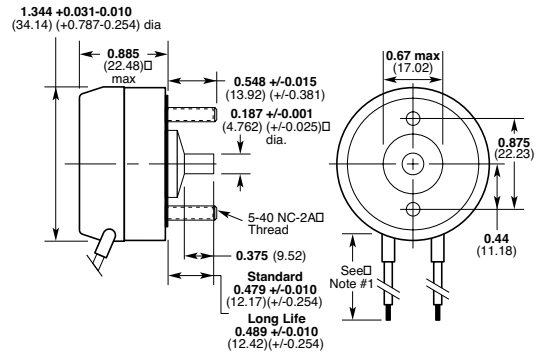

Armature Cover Configuration — Double Shaft

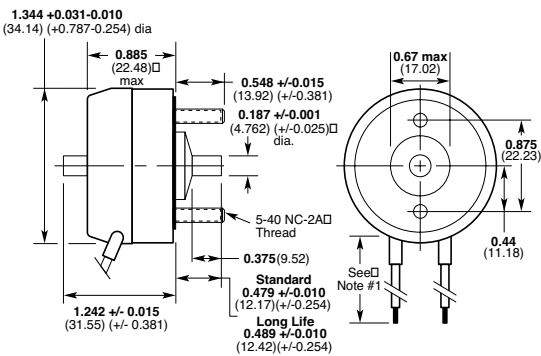

Notes:

- 1) All configurations have 10" (254 mm) minimum leads, 24 awg. PVC insulation.
- 2) For electrical specs and performance charts, see pages D16-D17.

All specifications subject to change without notice.

No Shaft

3 holes equally spaced located 1/2 rotary stroke +/-3° to left of center for R.H. stroke, right of center for L.H. stroke. 3-48 thread

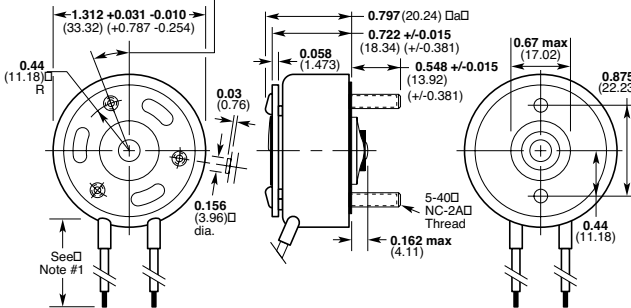

Base End Shaft

3 holes equally spaced located 1/2 rotary stroke +/-3° to left of center for R.H. stroke, right of center for L.H. stroke. 3-48 thread

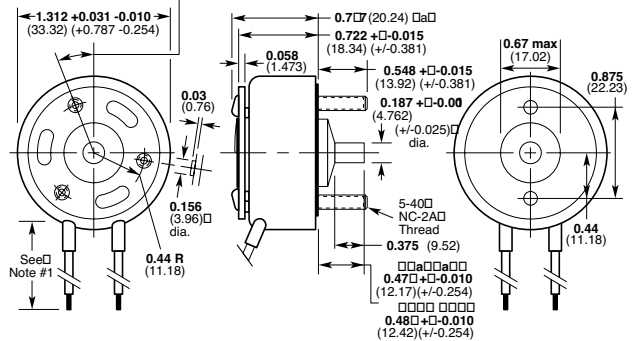

Armature End Shaft

3 holes equally spaced located 1/2 rotary stroke +/-3° to left of center for R.H. stroke, right of center for L.H. stroke. 3-48 thread

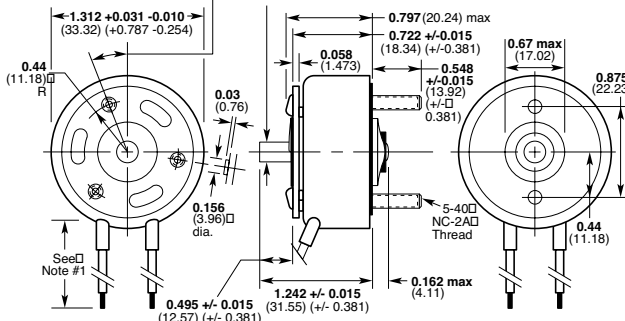

Double Shaft

3 holes equally spaced located 1/2 rotary stroke +/-3° to left of center for R.H. stroke, right of center for L.H. stroke. 3-48 thread

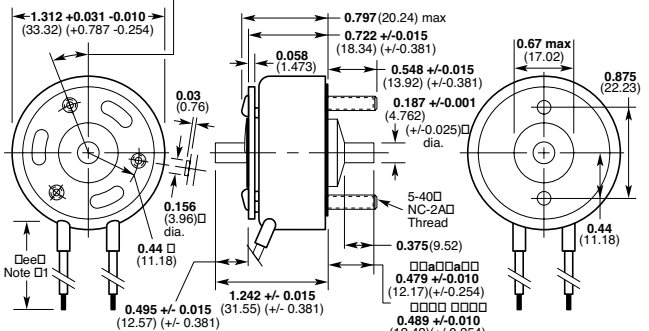

ROTARY Solenoids

Ledex® Rotary Solenoids 4E Dimensions

Inches (mm)

Armature Cover Configuration — Armature End Shaft

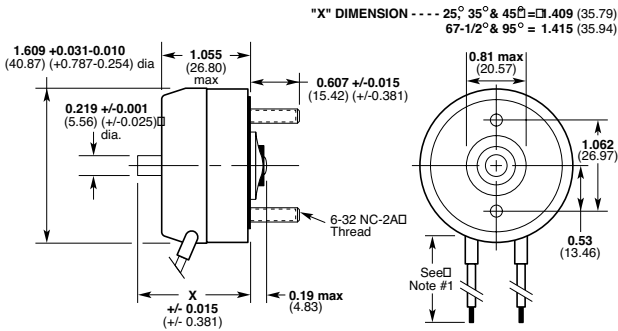

Armature Cover Configuration — Base End Shaft

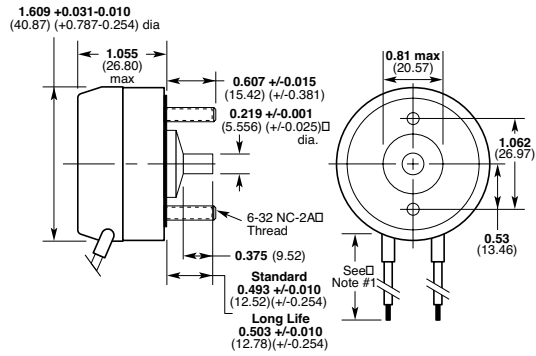

Armature Cover Configuration — Double Shaft

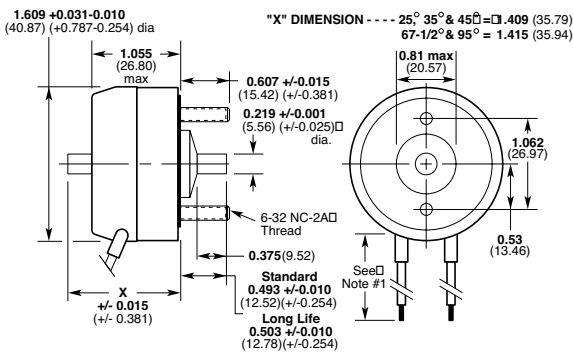

Notes:

- 1) All configurations have 10" (254 mm) minimum leads, 22 awg, PVC insulation.
- 2) For electrical specs and performance charts, see pages D18-D19.

All specifications subject to change without notice.

ROTARY Solenoids

No Shaft

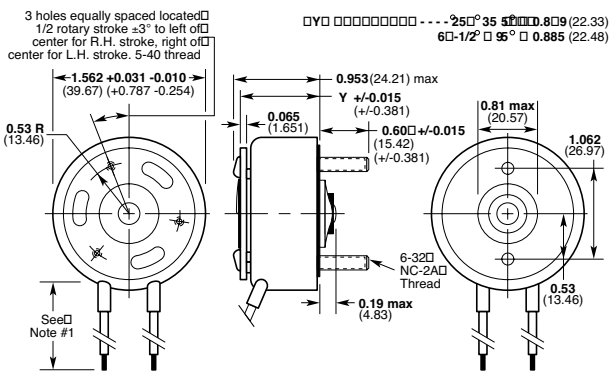

Base End Shaft

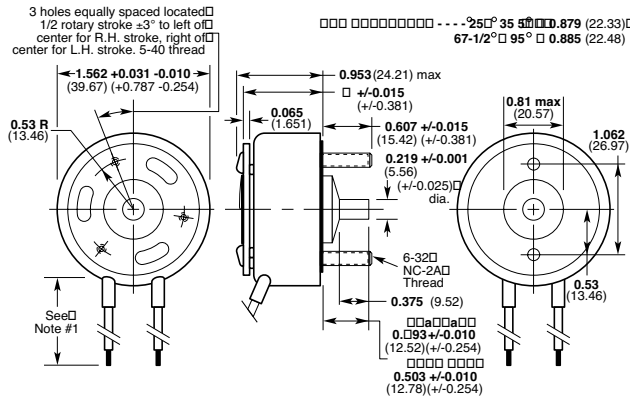

Armature End Shaft

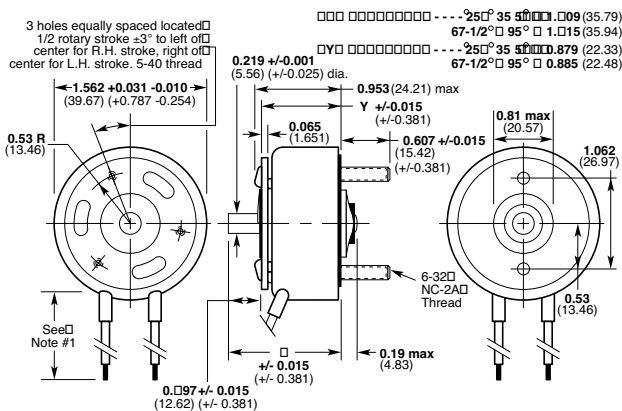

Double Shaft

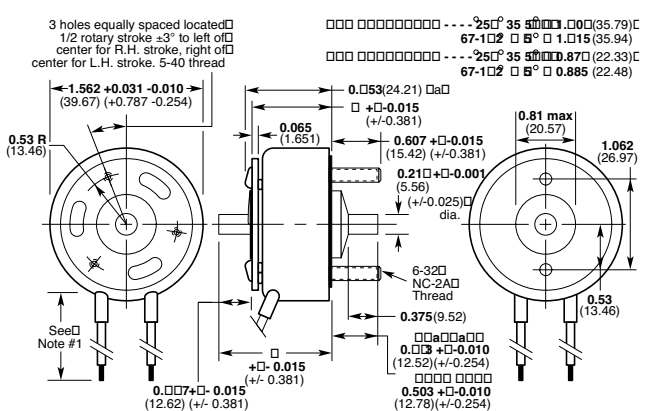

Ledex® Rotary Solenoids 5B Dimensions

Inches (mm)

Armature Cover Configuration — Base End Shaft

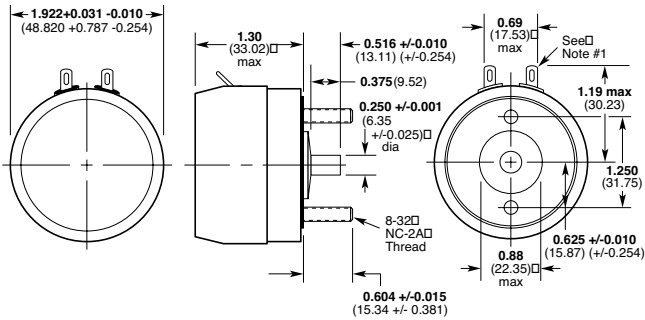

Notes:

- 1) All configurations have solder lug terminals, 0.170" (4.32) wide x 0.018" (0.457) thick.
- 2) For electrical specs and performance charts, see pages D20-D21.

All specifications subject to change without notice.

ROTARY Solenoids

No Shaft

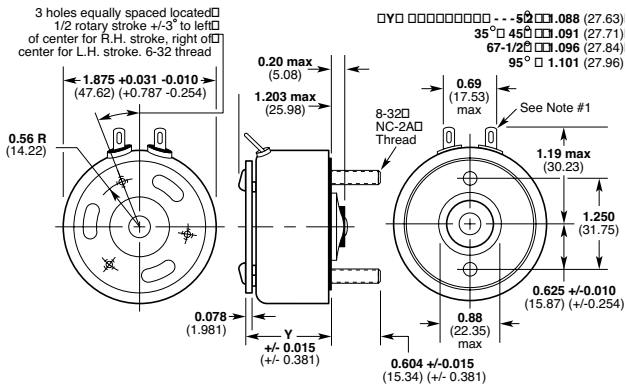

Base End Shaft

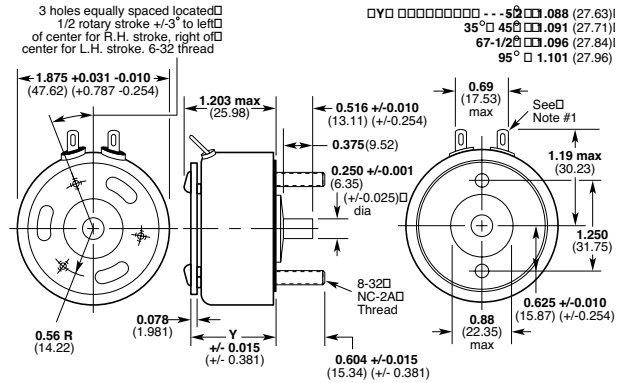

Armature End Shaft

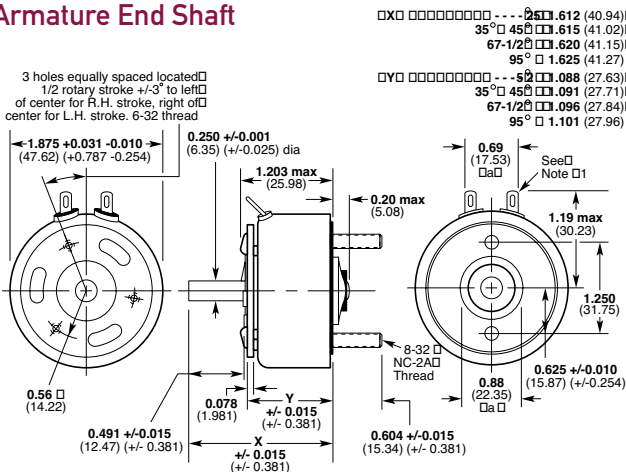

Double Shaft

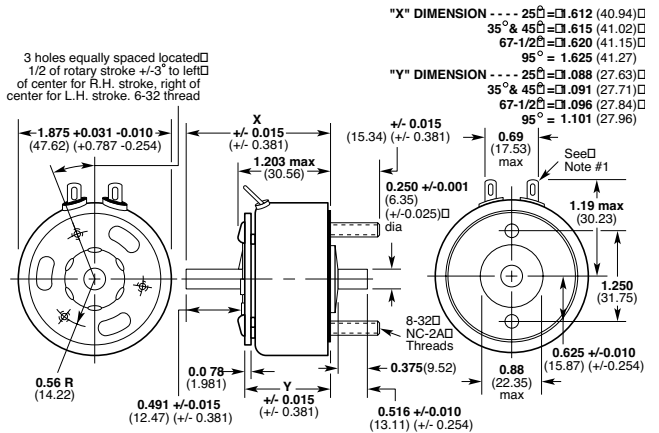

Ledex[®] Rotary Solenoids 5S Dimensions

Inches (mm)

Armature Cover Configuration — Armature End Shaft

Armature Cover Configuration — Base End Shaft

ROTARY Solenoids

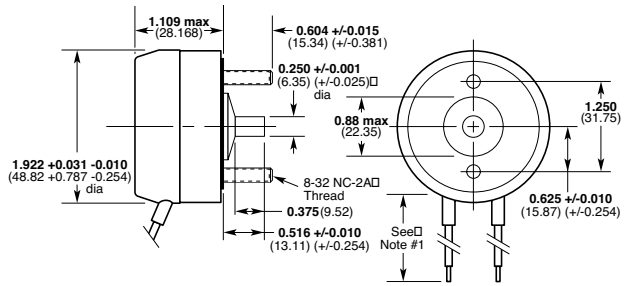
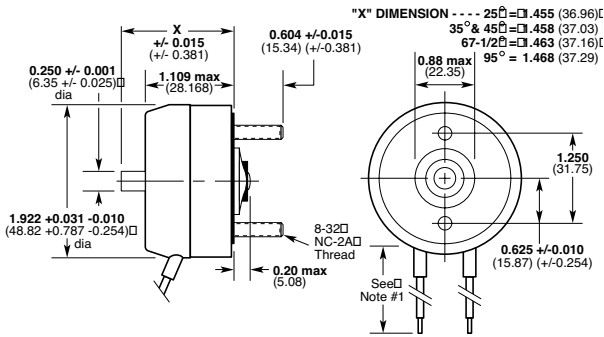

Armature Cover Configuration — Double Shaft

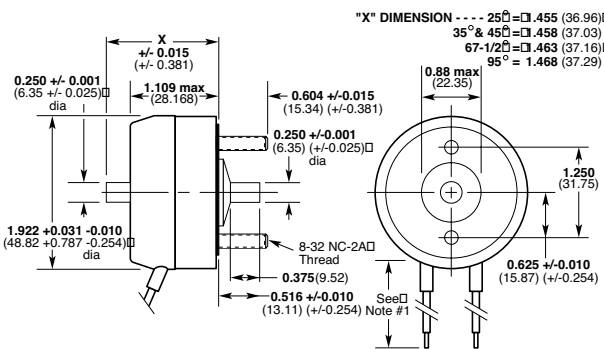

Notes:

- 1) All configurations have 10" (254 mm) minimum leads, 20 awg, PVC insulation.
- 2) For electrical specs and performance charts, see pages D22-D23.

All specifications subject to change without notice.

No Shaft

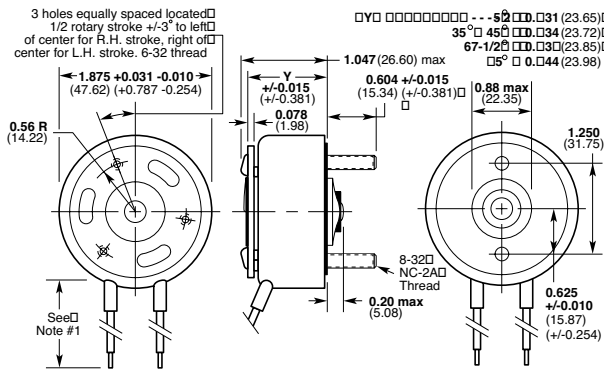

Base End Shaft

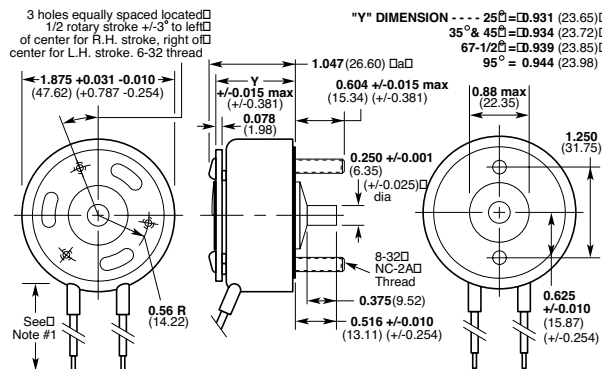

Armature End Shaft

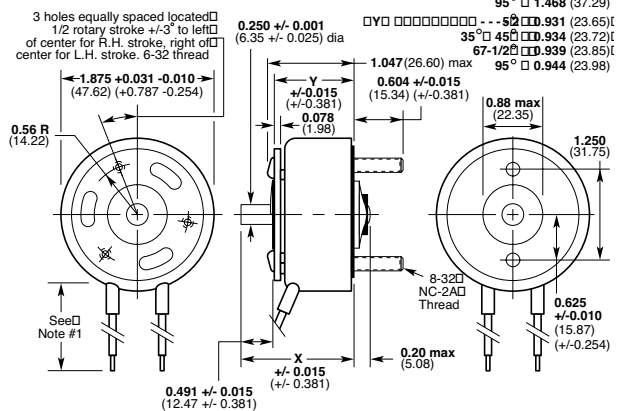

Double Shaft

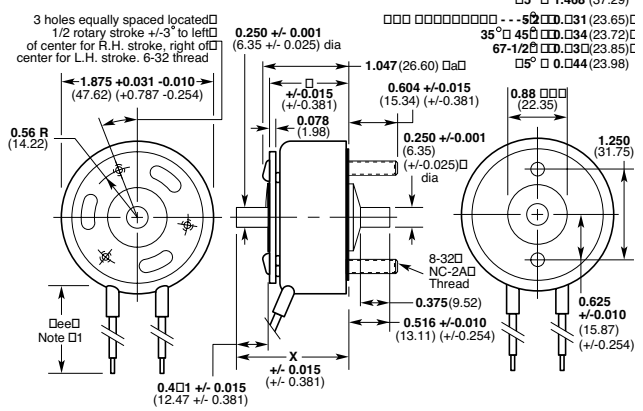

Ledex® Rotary Solenoids 6S Dimensions

Inches (mm)

Armature Cover Configuration — Armature End Shaft

Armature Cover Configuration — Base End Shaft

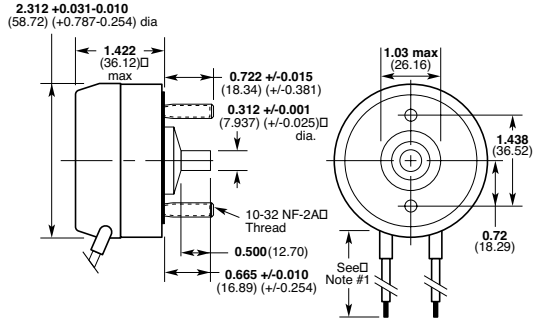
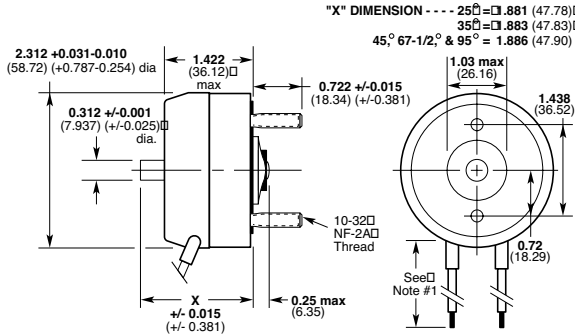

Armature Cover Configuration — Double Shaft

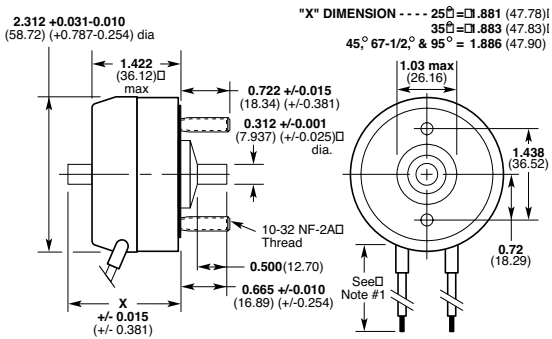

Notes:

- 1) All configurations have 10" (254 mm) minimum leads, 20 awg, PVC insulation.
- 2) For electrical specs and performance charts, see pages D24-D25.

All specifications subject to change without notice.

No Shaft

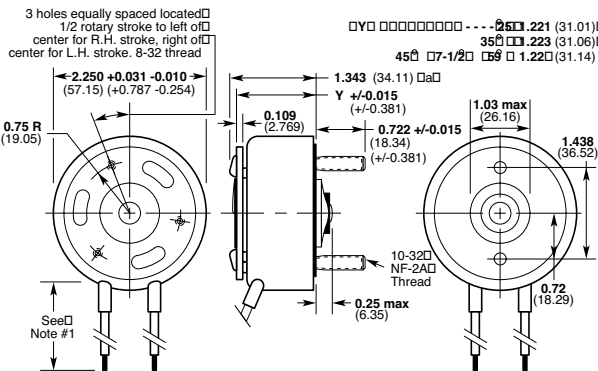

Base End Shaft

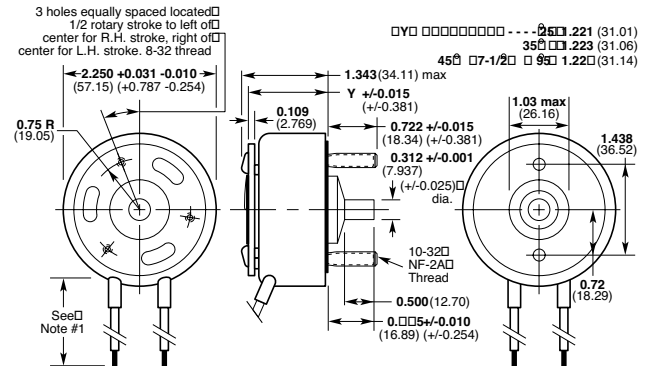

Armature End Shaft

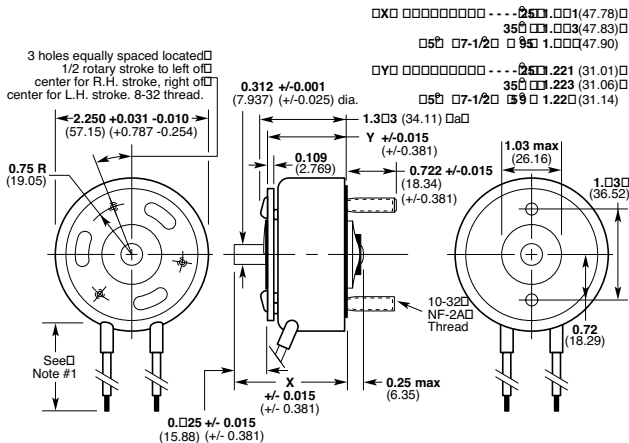

Double Shaft

