

## 0.5 A high-side driver intelligent power switch

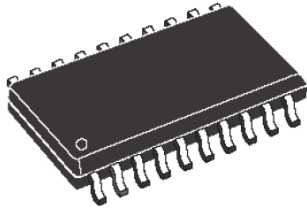

**SO20**

### Features

- 0.5 A output current
- 8 to 35 V supply voltage range
- Internal current limit
- Non-dissipative short-circuit protection
- Thermal shutdown
- Undervoltage lockout with hysteresis
- Internal negative voltage clamping for fast demagnetization
- Differential inputs with large common mode range and threshold hysteresis
- Open load detection
- Two diagnostic outputs
- Open ground protection
- Output status LED driver
- Immunity against burst transient (IEC 61000-4-4)
- ESD protection (human body model  $\pm 2$  kV)

### Description

The L6375D is a monolithic intelligent power switch in multipower BCD technology to drive inductive, capacitive or resistive loads with controlled output voltage slew rate and short-circuit protection. An internal clamping diode enables the fast demagnetization of inductive loads. Diagnostic for CPU feedback and extensive use of electrical protections make this device robust and suitable for industrial automation applications.

Product status link			
<a href="#">L6375D</a>			
Order code	Temperature range	Package	Packing
L6375D	-25 to +125 °C	SO20	Tube
L6375D013TR			Tape and reel

# 1 Pin configuration

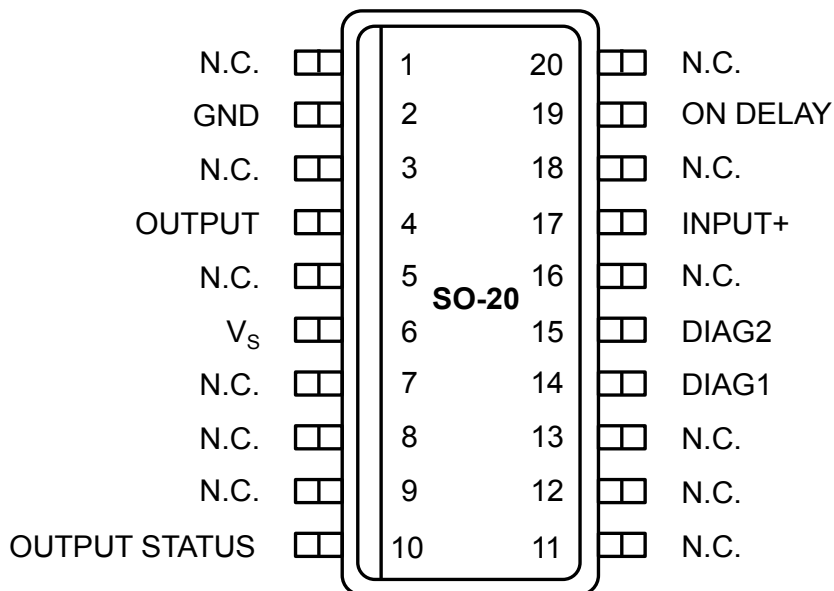
**Figure 1. Pin connections (top view)**

**Table 1. Pin description**

Pin	Pin name	Function
2	GND	Ground
4	OUTPUT	High side output with built-in current limitation
6	VS	Supply voltage input; the value of the supply voltage is monitored to detect undervoltage condition
10	Output status	This current source output is capable of driving an LED to signal the status of the output pin. The pin is active (source current) when the output pin is considered high
14	DIAG1	DIAGNOSTIC 1 output. This open drain reports the IC working conditions (see Table 6: Diagnostic truth table)
15	DIAG2	DIAGNOSTIC 2 output. This open drain reports the IC working conditions (see Table 6: Diagnostic truth table)
17	IN+	Comparator inverting input
19	ON-DELAY	Programmable ON time interval duration during short-circuit operation
1, 3, 5, 7, 8, 9, 11, 12, 13, 16, 18, 20	N.C.	Not connected

## 2 Maximum ratings

**Table 2. Absolute maximum ratings**

Symbol	Parameter	Value	Unit
$V_s$	Supply voltage ( $t_w \leq 10$ ms)	50	V
	Supply voltage (DC)	40	V
$V_S - V_{OUT}$	Supply to output differential voltage	Internally limited	V
$V_{od}$	ON DELAY pin voltage	-0.3 to 7	V
$I_{od}$	ON DELAY pin current	$\pm 1$	mA
$I_{out}$	Output current	Internally limited	A
$V_{out}$	Output voltage	Internally limited	V
$E_I$	Energy inductive load: $T_J = 85$ °C	200	mJ
$P_{tot}$	Power dissipation	Internally limited	W
$V_{diag}$	DIAGx pin voltage	-0.3 to 40	V
$I_{diag}$	DIAGx pin current	-10 to 10	mA
$I_i$	IN+ pin current	20	mA
$V_i$	IN+ pin voltage	-10 to $V_s + 0.3$	V
$T_{op}$	Ambient temperature, operating range	-25 to 85	°C
$T_J$	Junction temperature, operating range	-25 to 125	°C
$T_{stg}$	Storage temperature	-55 to 150	°C

**Table 3. Thermal data**

Symbol	Parameter	Value	Unit
$R_{th(JA)}$	Thermal resistance junction-ambient	65 max. <sup>(1)</sup>	°C/W
$R_{th(JP)}$	Thermal resistance junction-pins	15 max.	

1. When mounted on an FR4 printed circuit board with 0.5 cm<sup>2</sup> of Cu (at least 35 mm thick).

### 3 Electrical characteristics

$V_S = 24\text{ V}$ ;  $T_J = -25\text{ to }125\text{ }^\circ\text{C}$ , unless otherwise specified.

**Table 4. Electrical characteristics**

Symbol	Parameter	Test conditions	Min.	Typ.	Max.	Unit
$V_{smin}$	Supply voltage for valid diagnostic	$I_{diag} \geq 0.5\text{ mA}$ ; $V_{diag} = 1.5\text{ V}$	4		35	V
$V_S$	Operative supply voltage		8	24	35	V
$V_{sth1}$	Undervoltage threshold 1		7	7.5	8	V
$V_{sth2}$	Undervoltage threshold 2		6.5	7	7.5	V
$V_{shys}$	Undervoltage hysteresis		300	500	700	mV
$I_q$	Quiescent current	Output open		800		$\mu\text{A}$
$I_{qo}$		Output on		1.6		mA
$V_{ith}$	IN+ pin threshold voltage		0.8	1.3	2	V
$V_{iths}$	IN+ pin threshold hysteresis		50		400	mV
$V_{il}$	IN+ pin low level voltage		-7		0.8	V
$V_{ih}$	IN+ pin high level voltage	$V_S < 18\text{ V}$	2		$V_S - 3$	V
		$V_S > 18\text{ V}$	2		15	
$I_{ib}$	IN+ pin bias current	$V_i = -7\text{ to }15\text{ V}$	-250		250	$\mu\text{A}$
$I_{dch}$	Delay capacitor charging current	ON DELAY pin shorted-to-ground		2.5		$\mu\text{A}$
$V_{don}$	Output voltage drop	$I_{out} = 500\text{ mA}$ ; $T_J = 25\text{ }^\circ\text{C}$		200	280	mV
		$T_J = 125\text{ }^\circ\text{C}$		320	440	
		$I_{out} = 625\text{ mA}$ ; $T_J = 25\text{ }^\circ\text{C}$		250	350	
		$T_J = 125\text{ }^\circ\text{C}$		400	550	
$I_{olk}$	Output leakage current	$V_i = \text{low}$ ; $V_{out} = 0$			100	$\mu\text{A}$
$V_{ol}$	Output low-state voltage	$V_i = \text{high}$ ; pin floating		0.8	1.5	V
$V_{cl}$	Internal voltage clamp ( $V_S - V_{out}$ )	$I_o = 200\text{ mA}$ single pulsed = 300 ms	48	53	58	V
$I_{SC}$	Short-circuit output current	$V_S = 8\text{ to }35\text{ V}$ ; $R_i = 2\ \Omega$	0.75	1.1	1.5	A
$I_{old}$	Open load detection current	$V_i = V_{ih}$ ; $T_A = 0\text{ to }+85\text{ }^\circ\text{C}$	1	3	6	mA
$V_{oth1}$	Output status threshold 1 voltage		4.5	5	5.5	V
$V_{oth2}$	Output status threshold 2 voltage		4	4.5	5	V
$V_{ohys}$	Output status threshold hysteresis		300	500	700	mV
$I_{osd}$	Output status source current	$V_{out} > V_{oth1}$ ; $V_{OS} = 2.5\text{ V}$	2		4	mA
$V_{osd}$	Active output status driver drop voltage	$V_S - V_{OS}$ ; $I_{OS} = 2\text{ mA}$ ; $T_A = 0\text{ to }+85\text{ }^\circ\text{C}$		1.5	3	V
$I_{oslk}$	Output status driver leakage current	$V_{out} < V_{oth2}$ ; $V_{OS} = 0\text{ V}$ ; $V_S = 18\text{ to }35\text{ V}$			25	$\mu\text{A}$

Symbol	Parameter	Test conditions	Min.	Typ.	Max.	Unit
V <sub>dgl</sub>	Diagnostic drop voltage	D1 / D2 = L; I <sub>diag</sub> = 0.5 mA		40		mV
		D1 / D2 = L; I <sub>diag</sub> = 3 mA		250		
I <sub>dglk</sub>	Diagnostic leakage current	D1 / D2 = H; 0 < V <sub>dg</sub> < V <sub>S</sub> V <sub>S</sub> = 15.6 to 35 V			5	μA
T <sub>max.</sub>	Overtemperature upper threshold			150		°C
T <sub>hys</sub>	Overtemperature hysteresis			20		°C
<b>AC operation</b>						
t <sub>r</sub> - t <sub>f</sub>	Rise or fall time	V <sub>S</sub> = 24 V; R <sub>I</sub> = 70 Ω; R <sub>I</sub> to ground		20		μs
t <sub>d</sub>	Delay time			5		
dV/dt	Slew rate (rising and falling edge)		0.7	1	1.5	V/μs
t <sub>ON</sub>	On-time during short-circuit condition	50 pF < C <sub>DON</sub> < 2 nF		1.28		μs/pF
t <sub>OFF</sub>	Off-time during short-circuit condition			64		t <sub>ON</sub>
f <sub>max.</sub>	Maximum operating frequency			25		kHz
<b>Source drain NDMOS diode</b>						
V <sub>fSD</sub>	Forward on voltage	I <sub>fSD</sub> = 625 mA		1	1.5	V
I <sub>fP</sub>	Forward peak current	t <sub>p</sub> = 10 ms; duty cycle = 20%			2	A
t <sub>rr</sub>	Reverse recovery time	I <sub>fSD</sub> = 625 mA; dI <sub>fSD</sub> /dt = 25 A/μs		200		ns
t <sub>fr</sub>	Forward recovery time			50		ns

### 3.1 Schematic diagram

Figure 2. Block diagram

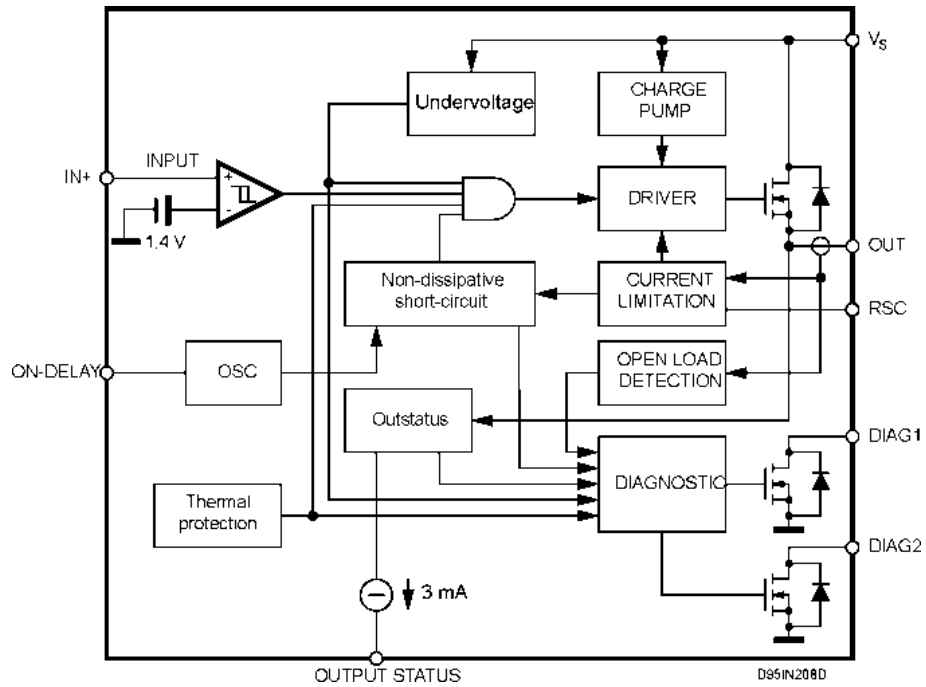
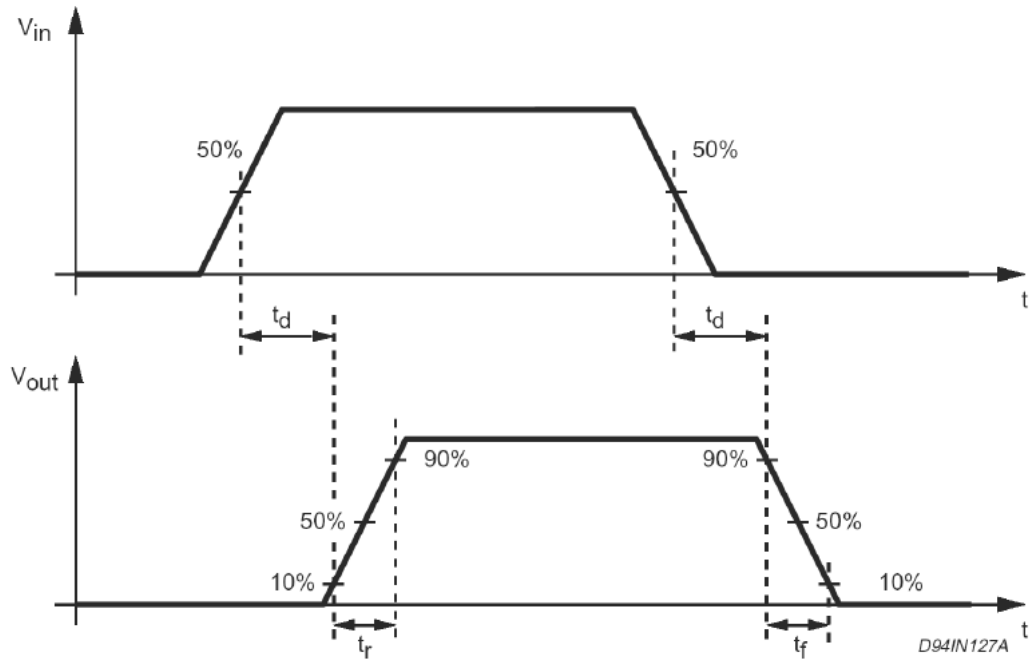

Figure 3. Switching waveforms



### 3.2 Input section

A single ended input TTL/CMOS compatible with a wide voltage range and high noise immunity (thanks to a built-in hysteresis) is available.

### 3.3 Overtemperature protection (OVT)

On-chip overtemperature protection provides an excellent protection of the device in extreme conditions. Whenever the temperature, measured on a central portion of the chip, exceeds  $T_{max.} = 150\text{ }^{\circ}\text{C}$  (typical value) the device shuts down, and the DIAG2 output goes low. Normal operation is resumed as the chip temperature (normally after few seconds) falls below  $T_{max.} - T_{hys} = 130\text{ }^{\circ}\text{C}$  (typical value). The hysteresis avoids that an intermittent behavior occurs.

### 3.4 Undervoltage protection (UV)

The supply voltage operates correctly in a range from 8 to 35 V. Below 8 V the overall system has to be considered not reliable. To avoid any malfunctioning, the supply voltage is continuously monitored to provide an undervoltage protection. As  $V_s$  falls below  $V_{sth} - V_{shys}$  (typically 7.5 V) the output power MOSFET switches off and DIAG1 and DIAG2 output go low. Normal operation is resumed as soon as  $V_s$  exceeds  $V_{sth}$ . The hysteretic behavior prevents intermittent operation at low supply voltage.

### 3.5 Overcurrent operation

In order to implement a short-circuit protection, the output power MOSFET is driven to linear mode to limit the output current to the  $I_{sc}$  value (1.1 A typical value).

This condition (current limited to the  $I_{sc}$  value) lasts for a  $t_{ON}$  time interval that can be set by a capacitor ( $C_{DON}$ ) connected to the ON DELAY pin according to the following formula:

**Equation 1:**

$$t_{ON} = 1.28\text{ }\mu\text{s/pF for } 50\text{ pF} < C_{DON} < 2\text{ nF}$$

After the  $t_{ON}$  interval has expired the output power MOSFET switches off for the  $t_{OFF}$  time interval:

**Equation 2:**

$$t_{OFF} = 64 \cdot t_{ON}$$

**Figure 4. Short-circuit operation waveforms**

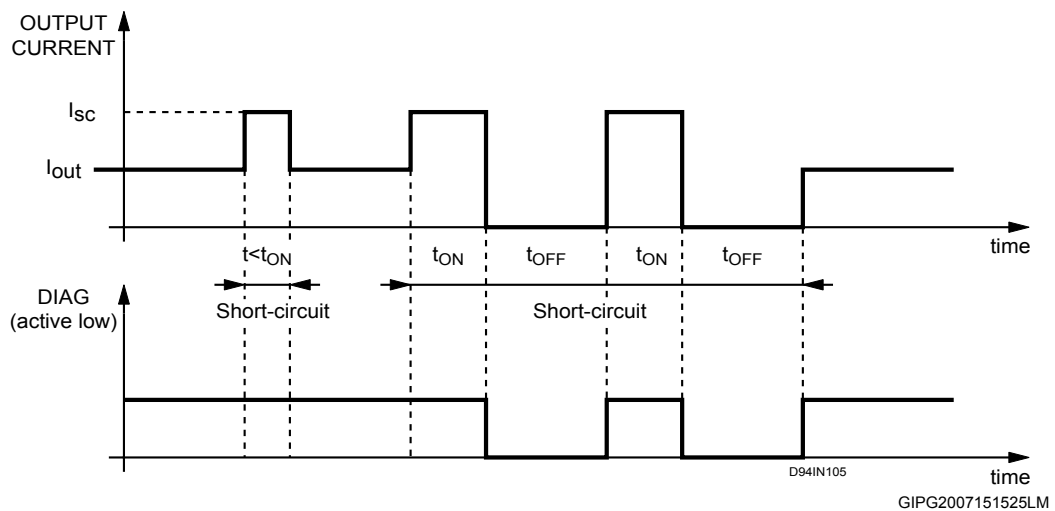

When the  $t_{OFF}$  interval has expired, the output power MOSFET switches on. In this manner two conditions may occur:

- the overload is still present. In this case, the output power MOSFET is again driven to linear mode (limiting the output current to  $I_{sc}$ ) for another  $t_{ON}$ , starting a new cycle
- the overload condition is removed, and the output power MOSFET is no longer driven to linear mode

This unique feature is called no-dissipative short-circuit protection and it ensures a very safe operation even in permanent overload conditions. The choice of the most appropriate value for the  $t_{ON}$  interval (the value of the

$C_{DON}$  capacitor) is very important, a delay (the  $t_{ON}$  itself) prevents the misleading short-circuit information is presented on the DIAG output, when capacitive loads are driven or incandescent lamp, a cold filament, has a very low resistive value. The non-dissipative short-circuit protection can be disabled (keeping  $t_{ON} = 0$  but with the output current still limited to  $I_{SC}$ , and diagnostic disabled) by shorting to ground the ON DELAY pin.

### 3.6 Diagnostic logic

The operating conditions of the device are permanently monitored and the following occurrences are indicated by DIAG1/DIAG2 open drain output pins, see [Section 3.8 Diagnostic truth table](#).

- Short-circuit vs. ground
- Short-circuit vs. VS
- Undervoltage (UV)
- Overtemperature (OVT)
- Open load, if the output current is less than 3 mA (typical value)

### 3.7 Demagnetization of inductive loads

An internal Zener diode, limiting the voltage across the power MOSFET between 50 and 60 V ( $V_{cl}$ ), provides safe and fast demagnetization of inductive loads without the external clamping devices. The maximum energy absorbed by an inductive load is specified as 200 mJ (at  $T_J = 85\text{ }^\circ\text{C}$ ).

### 3.8 Diagnostic truth table

**Table 5. Diagnostic truth table**

Diagnostic conditions	Input	Output	DIAG1	DIAG2
Normal operation	L	L	H	H
	H	H	H	H
Open load condition ( $I_o < I_{old}$ )	L	L	H	H
	H	H	L	H
Short to $V_S$	L	H	L	H
	H	H	L	H
Short-circuit to ground ( $I_o = I_{sc}$ ) (ON DELAY pin grounded) <sup>(1)</sup>	H	X	H	H
	L	L	H	H
Output DMOS open	L	L	H	H
	H	L	L	H
Overtemperature	L	L	H	L
	H	L	H	L
Supply undervoltage ( $V_S < V_{sth2}$ )	L	L	L	L
	H	L	L	L

1. A cold lamp filament or a capacitive load activates the current limiting circuit of the IPS, when the IPS is initially turned on.



## 4 Application circuits

Figure 5. Input comparator hysteresis

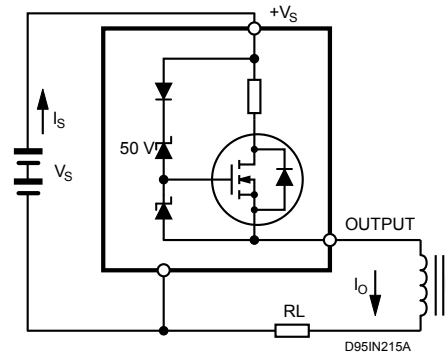

Figure 6. External demagnetization circuit (versus ground)

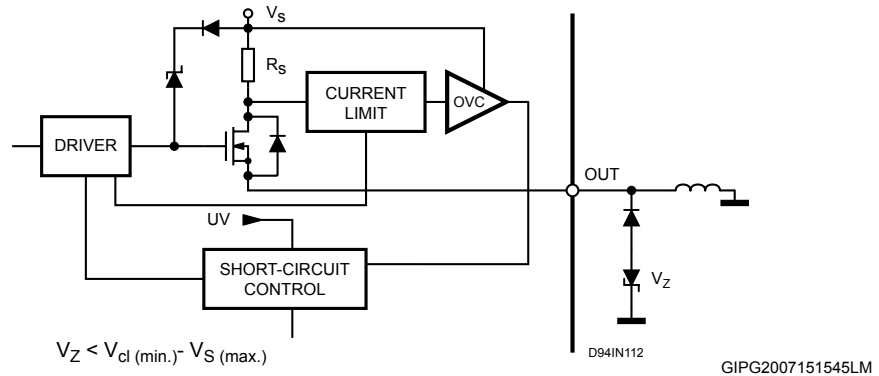

Figure 7. External demagnetization circuit (versus VS)

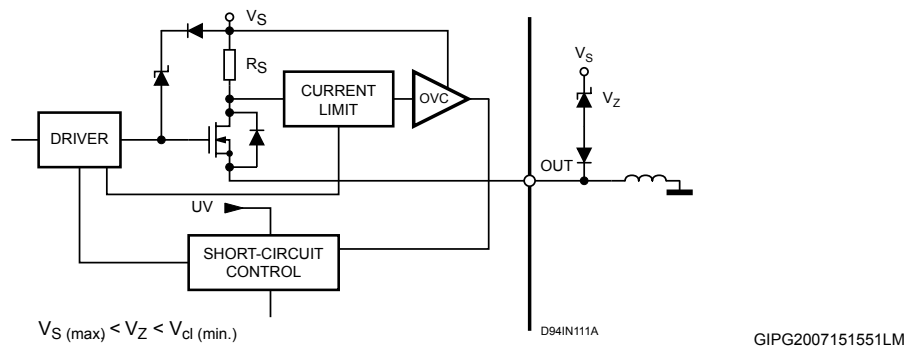
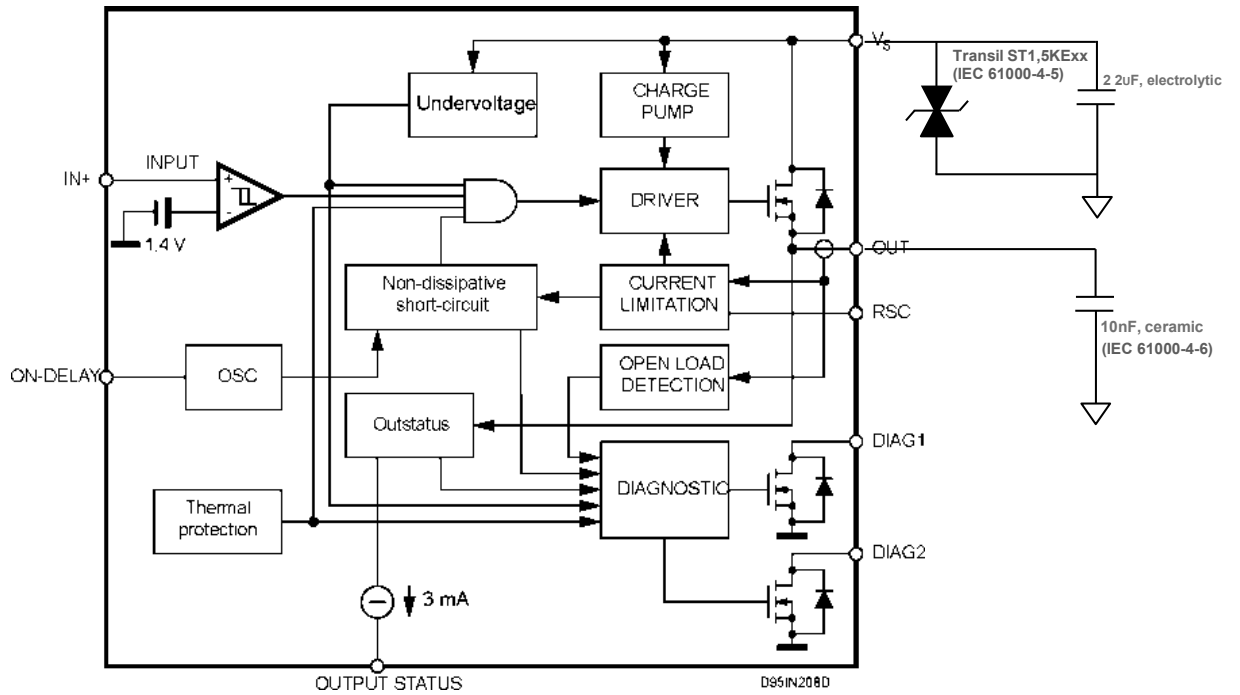

Figure 8. Application diagram



## 5 Package information

In order to meet environmental requirements, ST offers these devices in different grades of **ECOPACK** packages, depending on their level of environmental compliance. ECOPACK specifications, grade definitions and product status are available at: [www.st.com](http://www.st.com). ECOPACK is an ST trademark.

### 5.1 SO-20 package information

Figure 9. SO-20 package outline

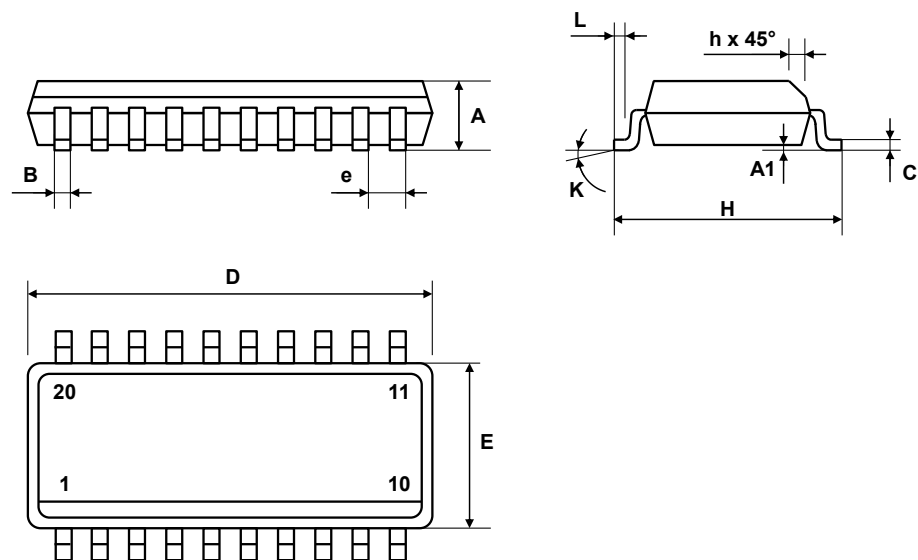

Table 6. SO20 mechanical data

Dim.	mm			inch		
	Min.	Typ.	Max.	Min.	Typ.	Max.
A	2.35		2.65	0.093		0.104
A1	0.1		0.3	0.004		0.012
B	0.33		0.51	0.013		0.020
C	0.23		0.32	0.009		0.013
D	12.6		13	0.496		0.512
E	7.4		7.6	0.291		0.299
e		1.27			0.050	
H	10		10.65	0.394		0.419
h	0.25		0.75	0.010		0.030
L	0.4		1.27	0.016		0.050
K	0° (min.)8° (max.)					

## 5.2 SO20 packing information

Figure 10. Shipping tube for SOIC SO20 (measure in mm)

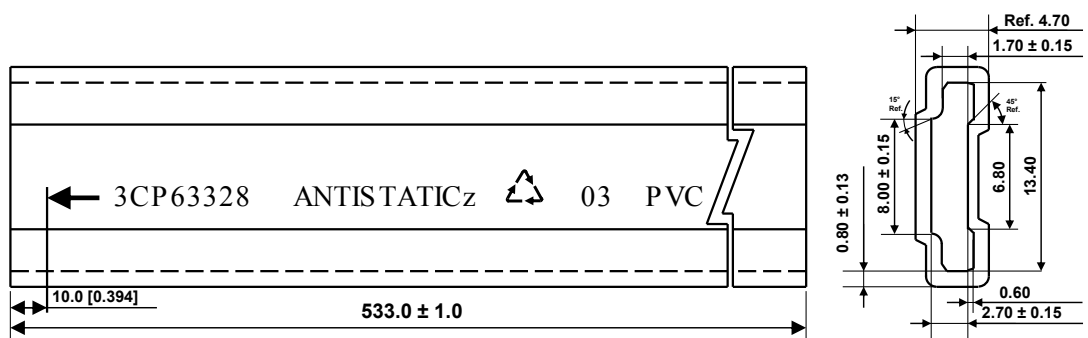

Figure 11. SOIC 20L wide body carrier tape drawing (supplier code 12)

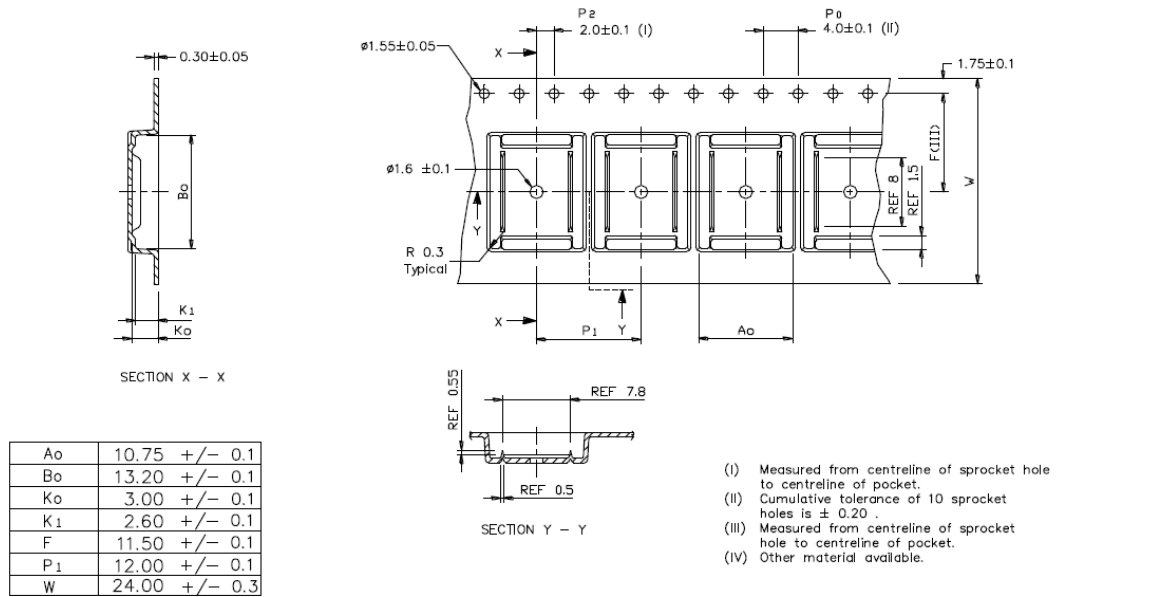

Figure 12. SO20 reel drawing

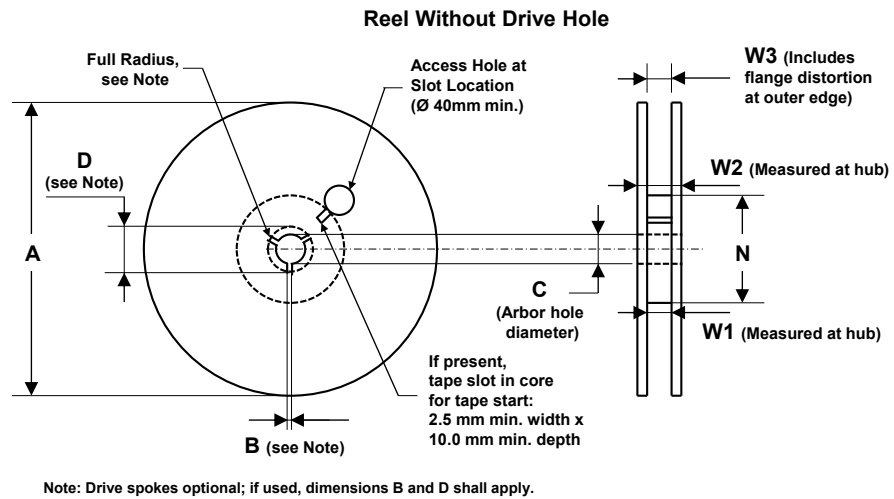

Table 7. SO20 reel dimensions

Dim.	mm		
	Min.	Typ.	Max.
A		330	
B	1.5		
C	12.8	13.0	13.5
D	20.2		
Tape size	8		200
W		24	
N		7" (178)	
W1 <sup>(1)</sup>		24.4	24.6
W2 max		30.4	

1. Measured at the hub

Figure 13. SO20 Reel side view drawing

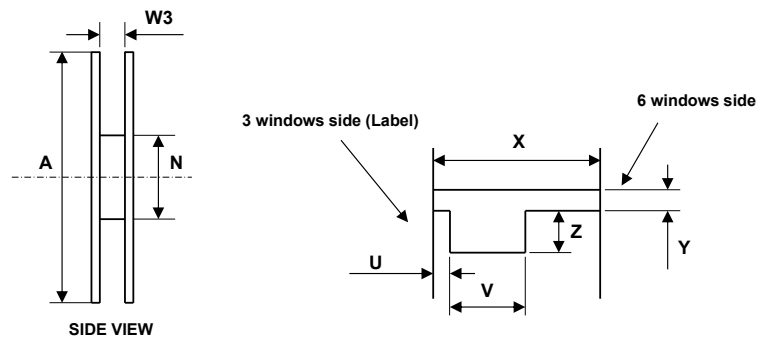

Table 8. SO20 reel side view dimensions

Dim.	mm		
	Min.	Typ.	Max.
Reel		7" hub (24mm)	
X	24.5	25	25.5
Y	0.95	1	1.05
Z	5.5	6	6.5
V	19	20	21
U	1.95	2	2.05

## Revision history

**Table 9. Document revision history**

Date	Revision	Changes
24-Jul-2007	1	Initial release.
29-Jun-2009	2	Updated Table 5 on page 7
21-Dec-2011	3	Updated Table 5 on page 7
15-May-2019	4	Updated <a href="#">Table 4. Electrical characteristics</a>