

SMART QUAD SWITCH

- Modified VDMOS Power Stage ($U_{DSBR} > 80V$)
- $RD_{SON} < 500\text{ m}\Omega$ ($T_j = 25^\circ C$)
- CMOS Compatible Inputs
- Enable Input (Reset)
- Outputs Capable of up to 2.2 Amperes
- Outputs Internally Clamped at 70V for Fast Inductive Load Switch Off
- Wide operating supply voltage from 4.7V up to 30V
- DIAGNOSTIC FUNCTIONS
- Open Load Detection (Output off, 100 μ s-filtering time)
- Short to Ground Detection (Output off, 100 μ s-filtering time)
- Short to Battery Detection (Output on)
- Over temperature detection (Output on)
- Storage of last fault in 8 Bit - Serial Register
- Fault Signal Indication at Serial Data Out without need to read out the Serial Interface
- Daisy Chainable Serial Diagnostic

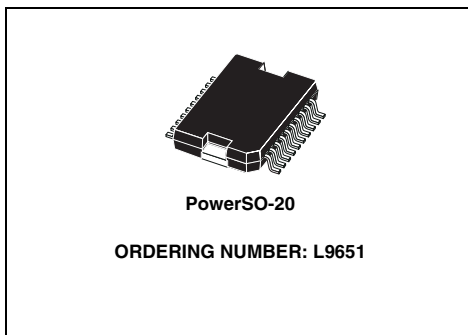

- Serial Interface Clock Frequency up to 500kHz

DESCRIPTION

The L9651 consists of four identical low side power switches. A serial diagnostic interface indicates failure mode of each switch (short circuit to V_{BAT} or ground and open load or over temperature).

BLOCK DIAGRAM

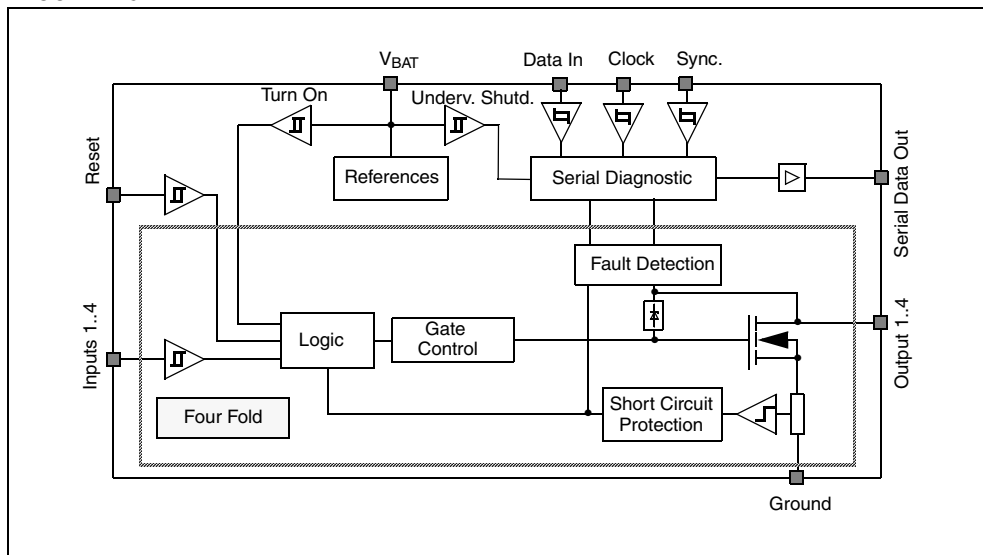

PIN CONNECTION (Top view)

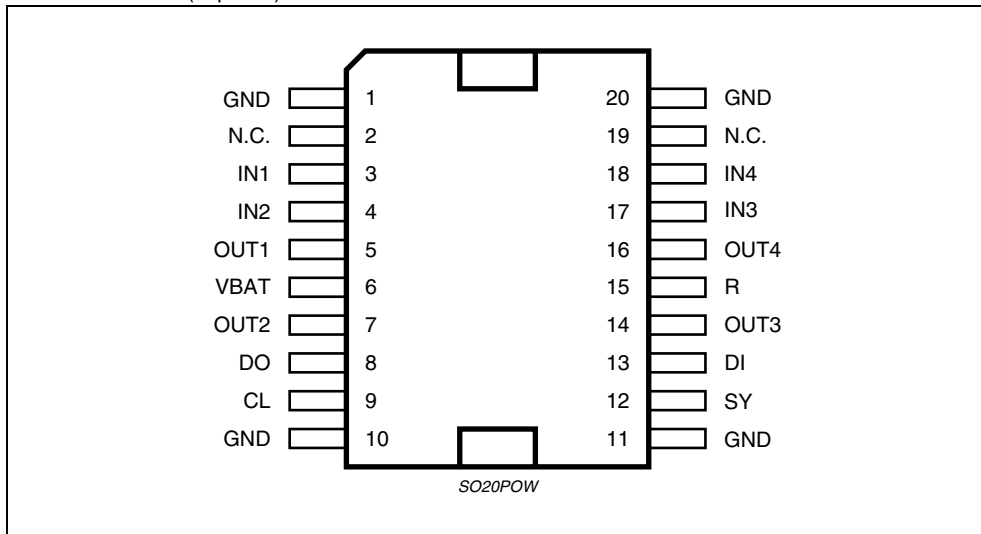

PIN FUNCTION

N°	Pin	Function
1, 10, 11, 20	GND	Ground
2, 19	N.C.	Not Connected
3	IN1	Input 1
4	IN2	Input 2
5	OUT1	Output 1
6	VBAT	Supply Voltage
7	OUT2	Output 2
8	DO	Serial Data Out
9	CL	Clock
12	SY	Synchronization
13	DI	Serial Data In
14	OUT3	Output 3
15	R	Reset
16	OUT4	Output 4
17	IN3	Input 3
18	IN4	Input 4

ABSOLUTE MAXIMUM RATINGS

Symbol	Parameter	Value	Unit
T _{STG}	Storage Temperature	-55 to 150	°C
T _J	Operating Junction Temperature	-40 to 150	°C
V _{BAT}	DC Supply Voltage	-2 to 30	V
V _{BATTr}	Transient Supply Voltage; t < 400ms	40	V
V _{OUT}	Output Voltage	65	V
V _{OUTTr}	Transient Output Voltage; during clamping	78	V
E _{CL}	Output Clamping energy; repetition rate < 100 Hz	10	mJ
-I _{OUT}	Output reverse current	2	A
V _R , V _{INi} , V _{DI} , V _{CLVSY}	Control Input voltage	-0.3 to 6.5	V
V _{DO}	Control Output voltage	-0.3 to 6.5	V

THERMAL DATA

Symbol	Parameter	Value	Unit
R _{th j-case}	Thermal Resistance Junction to Case	2.5	°C/W

ELECTRICAL CHARACTERISTICS (6.5V < V_{BAT} < 25V, -40 < T_J < 150°C)

Symbol	Parameter	Test Condition	Min.	Typ.	Max.	Unit
Supply Voltage						
V _{BATU}	Turn on threshold voltage		2.0		4.7	V
I _{BAT}	Supply current	V _{BAT} = 14V V _{OUTi} > 0V	4	10	15	mA
Output stage						
R _{DSON}	On resistance	V _{BAT} = 14V T _J = 25°C; I _{out} = 1A			500	mΩ
		V _{BAT} = 14V T _J = 150°C; I _{out} = 1A			850	mΩ
V _{CL}	Clamping voltage, inductive load	I _{out} = 0.5 A	63	70	76	V
I _{OUTi}	Over current shutdown (Shutdown latch resets with pos. slope at INi)	T _J = -40°C	3.0		4.3	A
		T _J = 25°C	2.5		3.7	A
		T _J = 150°C	2.2		3.5	A
Output leakage current see: Open load diagnostic current						

ELECTRICAL CHARACTERISTICS (continued)

Symbol	Parameter	Test Condition	Min.	Typ.	Max.	Unit
Logic Inputs IN1...IN4, SY, CL, DI, R						
V_{IN1LH} V_{SYLH} V_{CLLH} V_{RLH} V_{D1LH}	Input High level		3.5		6.5	V
V_{IN1HL} V_{SYHL} V_{CLHL} V_{RHL} V_{D1HL}	Input Low level		-0.3		1.5	V
V_{IN1h} V_{SYh} V_{CLh} V_{Rh} V_{D1h}	Hysteresis		0.2		1	V
- I_{Ni} - I_{SY} - I_{CL} - I_R	Input current IN1 ... IN4, SY, CL, R (Internal pull up current source)	$V_{INi} = 0V$	10	40	120	μA
		$V_{SY} = 0V$ $V_{CL} = 0V$ $V_R = 0V$	10		80	
- I_{DI}	Input current DI (Internal pull up current source)	$V_{DI} = 0V$	120	220	250	μA
Timing						
t_{don}	Turn on delay			7.5		μs
t_{doff}	Turn off delay			7.5		μs
S_{on}	Switch on slew rate			10		V/ μs
S_{off}	Switch off slew rate			15		V/ μs
t_{oc}	Over current detection time			0.5		μs
t_v	Open load filtering time		60	100	200	μs
t_v	Short to GND filtering time		60	100	200	μs
f_{CL}	Serial clock frequency		0		500	kHz
t_{vDV}	DO: Data valid time		0.03		1	μs
t_{vset}	DI: Data settling time		0.5			μs
t_{vhold}	DI: Data hold time		0			μs
Diagnostic						
V_{BATDU}	Under voltage threshold		4.7		7.5	V
Serial Data output (External pull up required)						
V_{DO}	Data output low voltage	$I_{DO} < 1.6mA$ $7.5V < V_{BAT} < 22V$	0		0.45	V
$ I_{DO} $	Data output leakage current				10	μA

ELECTRICAL CHARACTERISTICS (continued)

Symbol	Parameter	Test Condition	Min.	Typ.	Max.	Unit
Output voltage monitoring Output off						
V _{OL}	Open load threshold voltage (fault detected if V _{OUTI} < V _{OL})	7.5V < V _{BAT} < 22V		2/3V _{BAT}		
V _{SG}	Short to GND threshold voltage (fault detected if V _{OUTI} < V _{SG})	7.5V < V _{BAT} < 22V		1/3V _{BAT}		
Open load diagnostic current Output off						
	Open load output voltage	I _{OUT} = 0 A V _{INI} = 5V 7.5V < V _{BAT} < 22V		1/2V _{BAT}		
- I _{OUTI}	Output current	V _{OUT} = 1V V _{INI} = 5V	50	100	150	μA
I _{OUTI}	Output current	V _{OUT} = V _{BAT} V _{INI} = 5V 7.5V < V _{BAT} < 22V	200	320	500	μA
Overload Diagnostic						
	Over temperature diagnostic	T _J		175		°C
I _{OUTI}	Over current	T _J = -40°C	3.0		4.3	A
		T _J = 25°C	2.5		3.7	A
		T _J = 150°C	2.2		3.5	A

Figure 1. Typical Timing Diagram for Serial Diagnostic

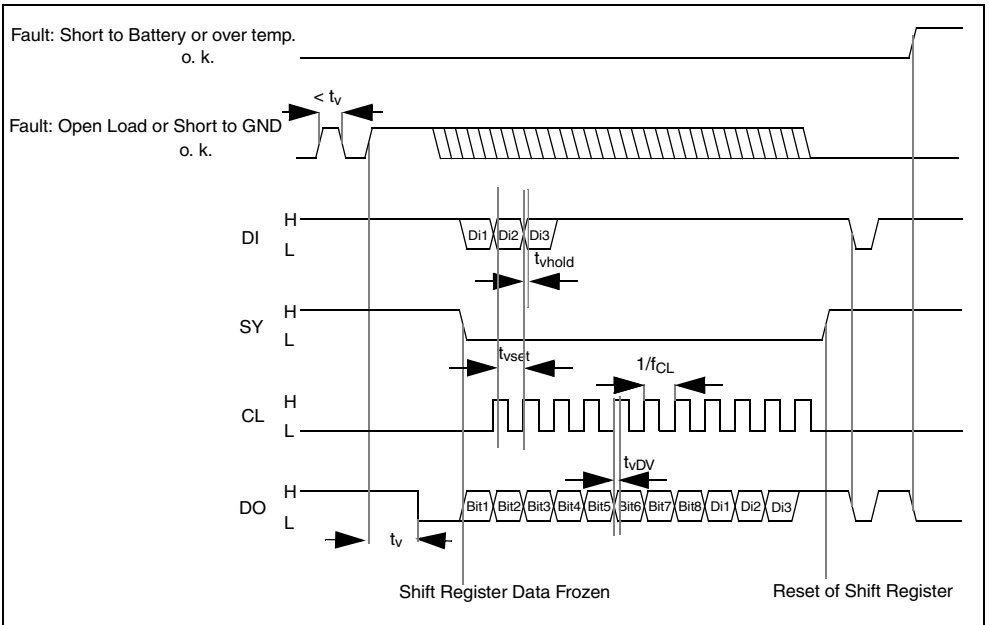

Figure 2. Serial Interface Error Coding

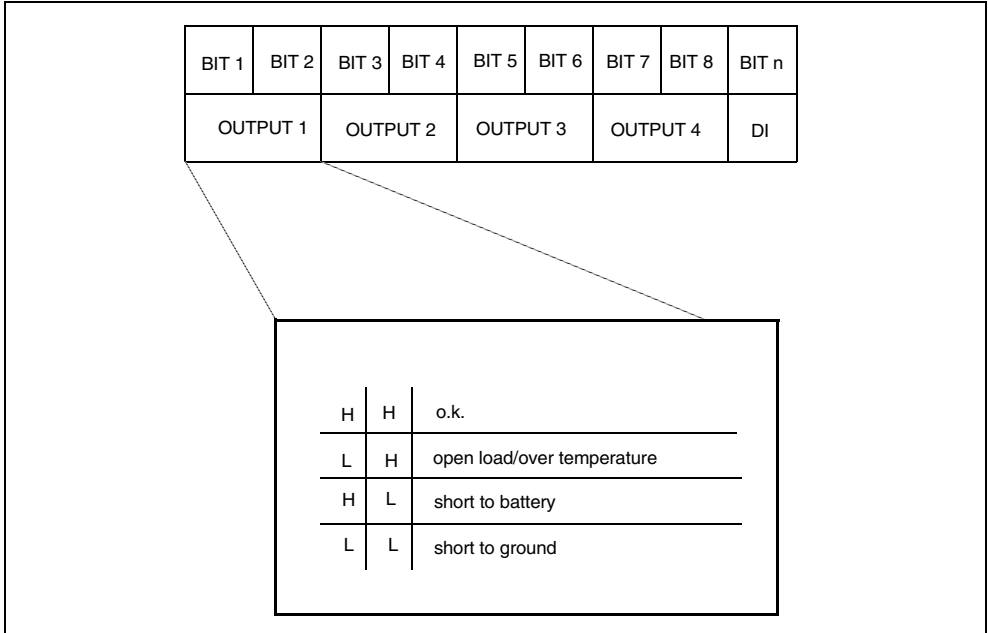

Figure 3. Output voltage TIMING for inductive load

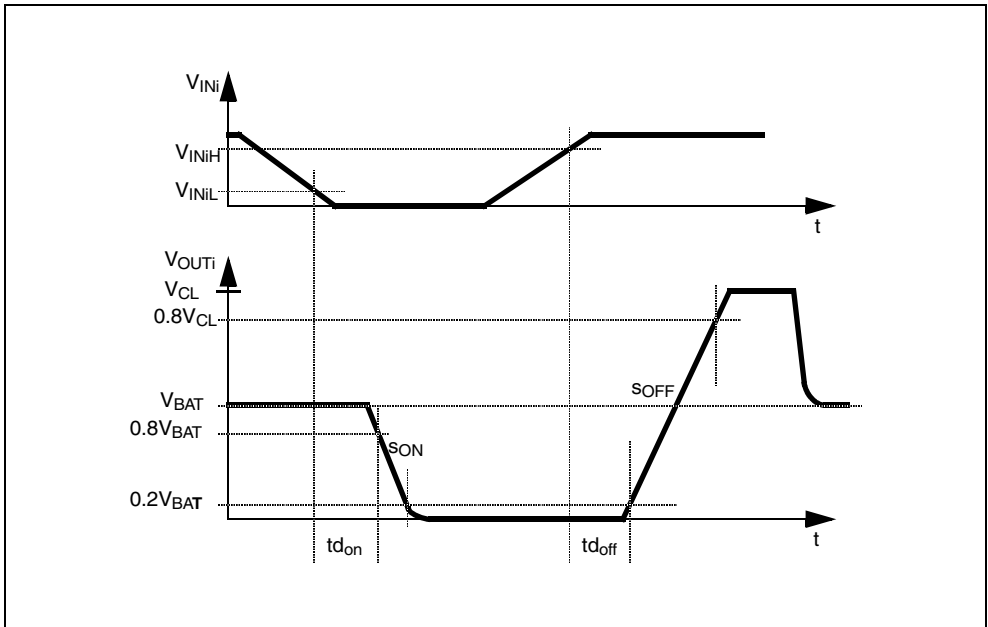
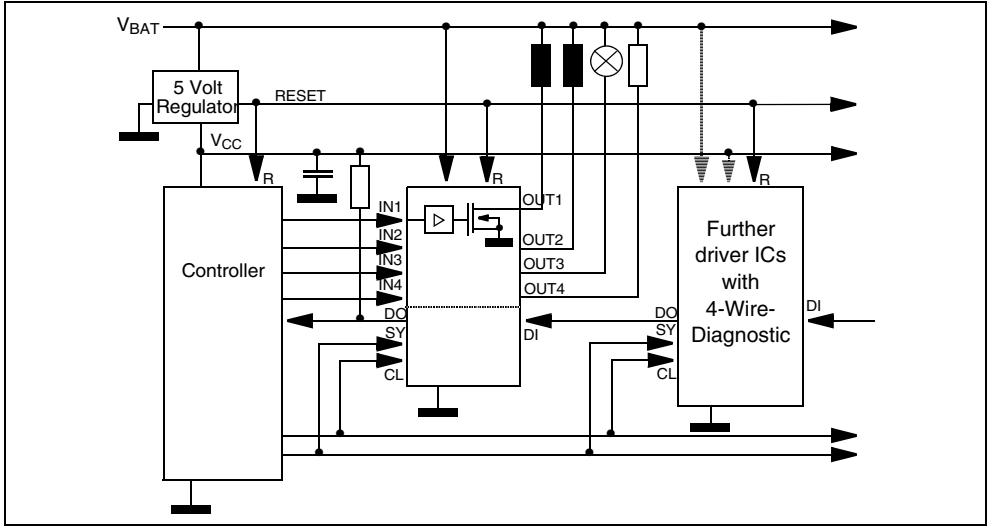

Figure 4. Application Circuit



DIM.	mm			inch		
	MIN.	TYP.	MAX.	MIN.	TYP.	MAX.
A			3.6			0.142
a1	0.1		0.3	0.004		0.012
a2			3.3			0.130
a3	0		0.1	0.000		0.004
b	0.4		0.53	0.016		0.021
c	0.23		0.32	0.009		0.013
D (1)	15.8		16	0.622		0.630
D1 (2)	9.4		9.8	0.370		0.386
E	13.9		14.5	0.547		0.570
e		1.27			0.050	
e3		11.43			0.450	
E1 (1)	10.9		11.1	0.429		0.437
E2			2.9			0.114
E3	5.8		6.2	0.228		0.244
G	0		0.1	0.000		0.004
H	15.5		15.9	0.610		0.626
h			1.1			0.043
L	0.8		1.1	0.031		0.043
N	8°(typ.)					
S	8°(max.)					
T		10			0.394	

- (1) "D and E1" do not include mold flash or protrusions.
 - Mold flash or protrusions shall not exceed 0.15mm (0.006")
 - Critical dimensions: "E", "G" and "a3".
 (2) For subcontractors, the limit is the one quoted in jecdec MO-166

OUTLINE AND MECHANICAL DATA

Weight: 1.9gr

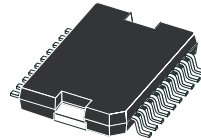

JEDEC MO-166

PowerSO-20

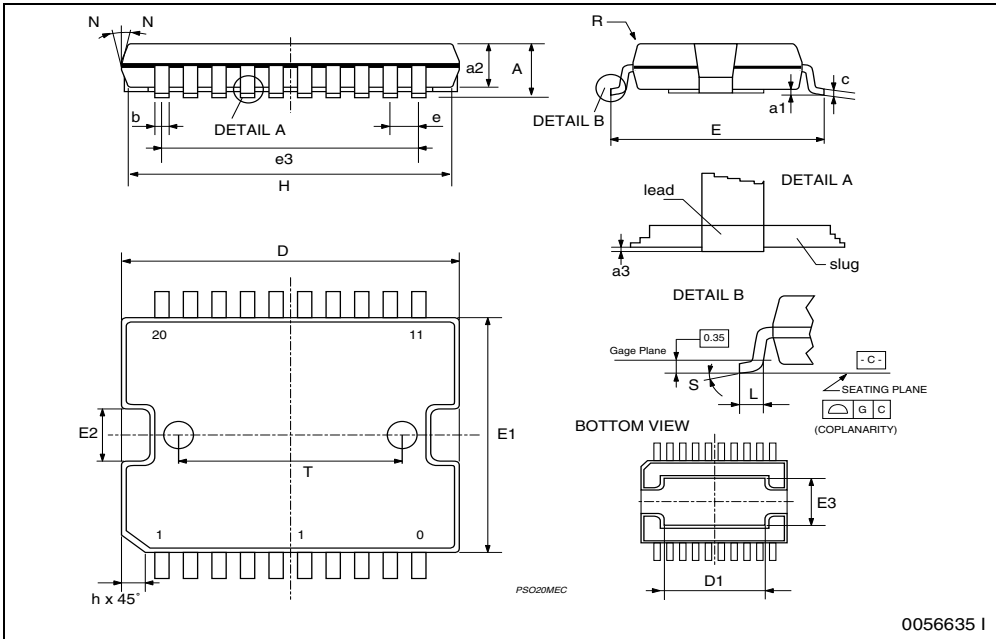

0056635 I