

Cascadable Amplifier 10 - 1000 MHz

Rev. V2

Features

- SYMMETRICAL CLIPPING:
GOOD EVEN-ORDER SUPPRESSION
- MEDIUM OUTPUT LEVEL: +10 dBm (TYP.)
- HIGH THIRD-ORDER INTERCEPT POINT:
+28 dBm (TYP.)
- FAST PULSE RECOVERY TIME: < 50 NSEC

Description

The LA17 limiting amplifier is a discrete hybrid design, which uses thin film manufacturing processes for accurate performance and high reliability. This design uses a Schottky diode limiter circuit at the input, and a single stage bipolar transistor feedback amplifier at the output. An RF choke is used for DC power supply decoupling. Both TO-8 and Surface Mount packages are hermetically sealed, and MIL-STD-883 environmental screening is available.

Product Image

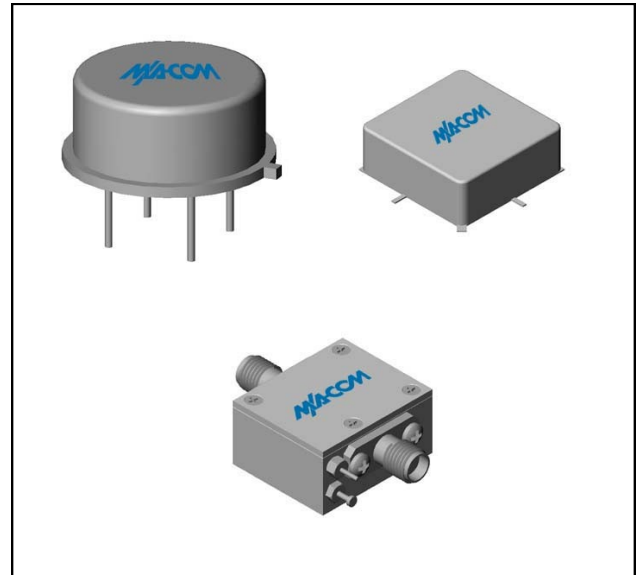

Ordering Information

Part Number	Package
LA17	TO-8
SMLA17	Surface Mount
CLA17 **	SMA Connectorized

** The connectorized version is not RoHs compliant.

Electrical Specifications: $Z_0 = 50\Omega$, $V_{CC} = +15 V_{DC}$

Parameter	Units	Typical	Guaranteed	
		25°C	0° to 50°C	-54° to +85°C*
Frequency	MHz	5-1100	10-1000	10-1000
Small Signal Gain (min)	dB	11.5	10.5	9.5
Gain Flatness (max)	dB	±0.3	±0.5	±0.7
Noise Figure (max)	dB	5.8	6.7	7.2
Power Output @ 1 dB comp. (min)	dBm	+10.0	+7.0	+5.0
Output Limiting Level (max) Pin = +20 dBm	dBm	+15.0	+16.0	+17.0
VSWR Input / Output (max)		<1.7:1/ <1.7:1	1.9:1 / 1.9:1	2.0:1 / 2.0:1
DC Current @ 15 Volts (max)	mA	55	57	59

Absolute Maximum Ratings

Parameter	Absolute Maximum
Storage Temperature	-62°C to +125°C
Case Temperature	+125°C
DC Voltage	+17 V
Continuous Input Power	+23 dBm
Short Term Input power (1 minute max.)	400 mW
Peak Power (3 µsec max.)	1 W
"S" Series Burn-In Temperature (case)	125°C

Thermal Data: $V_{CC} = +15 V_{DC}$

Parameter	Rating
Thermal Resistance θ_{jc}	45°C/W
Transistor Power Dissipation P_d	0.448 W
Junction Temperature Rise Above Case T_{jc}	20.2°C

1 * Over temperature performance limits for part number CLA17, guaranteed from 0°C to +50°C only.

Typical Performance Curves at +25°C

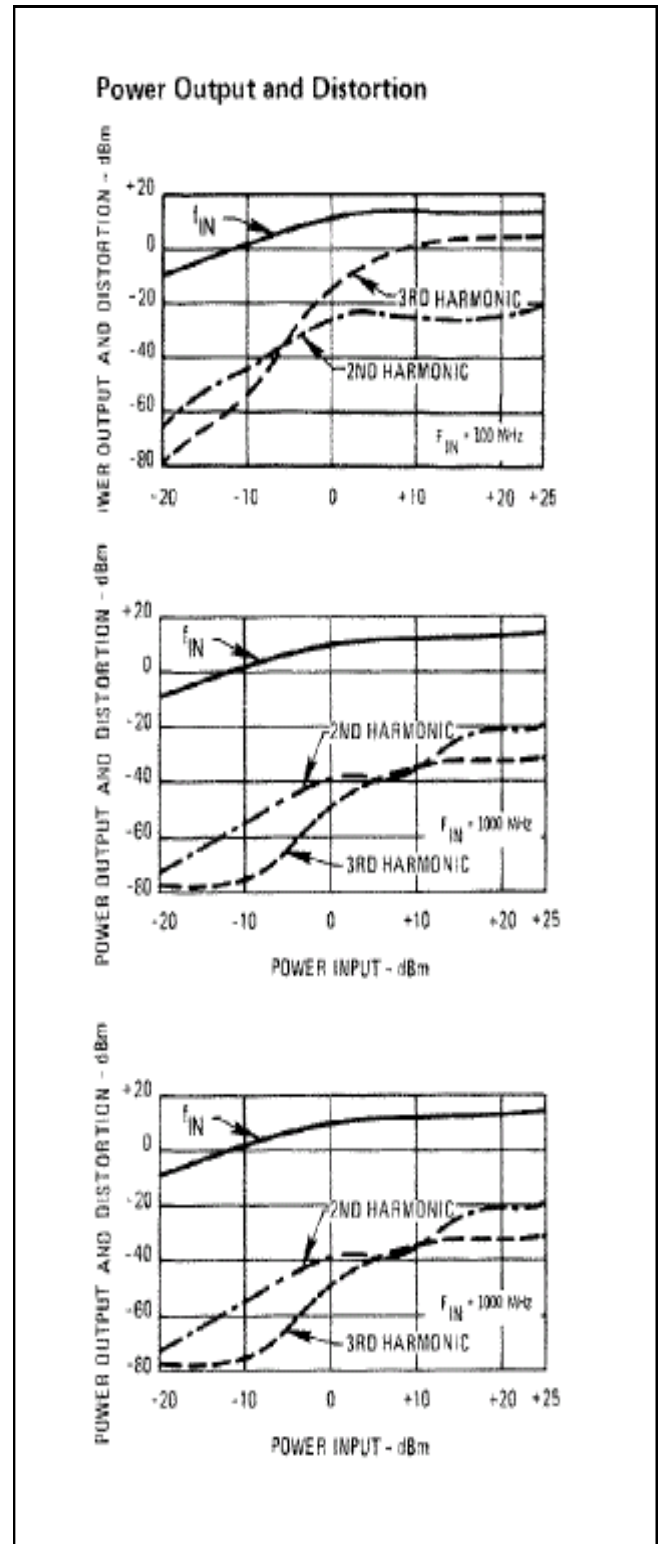
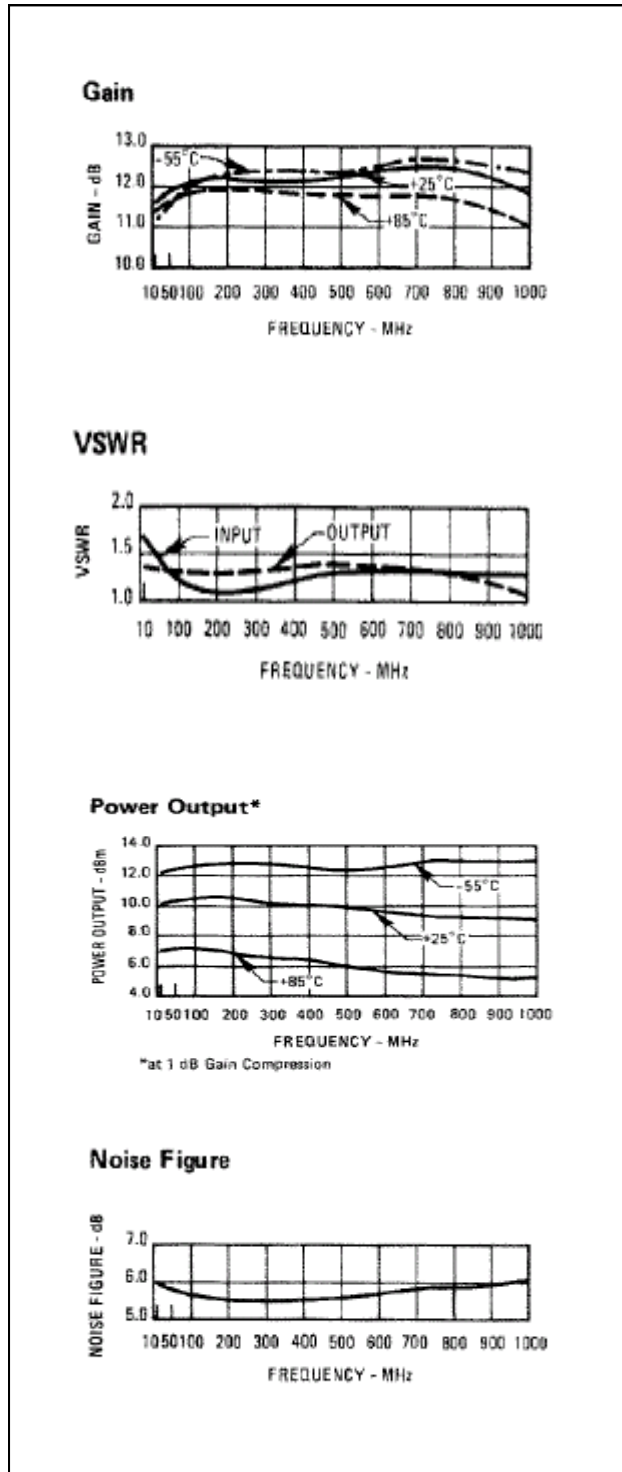

Cascadable Amplifier 10 - 1000 MHz

Rev. V2

Typical Performance Curves at +25°C

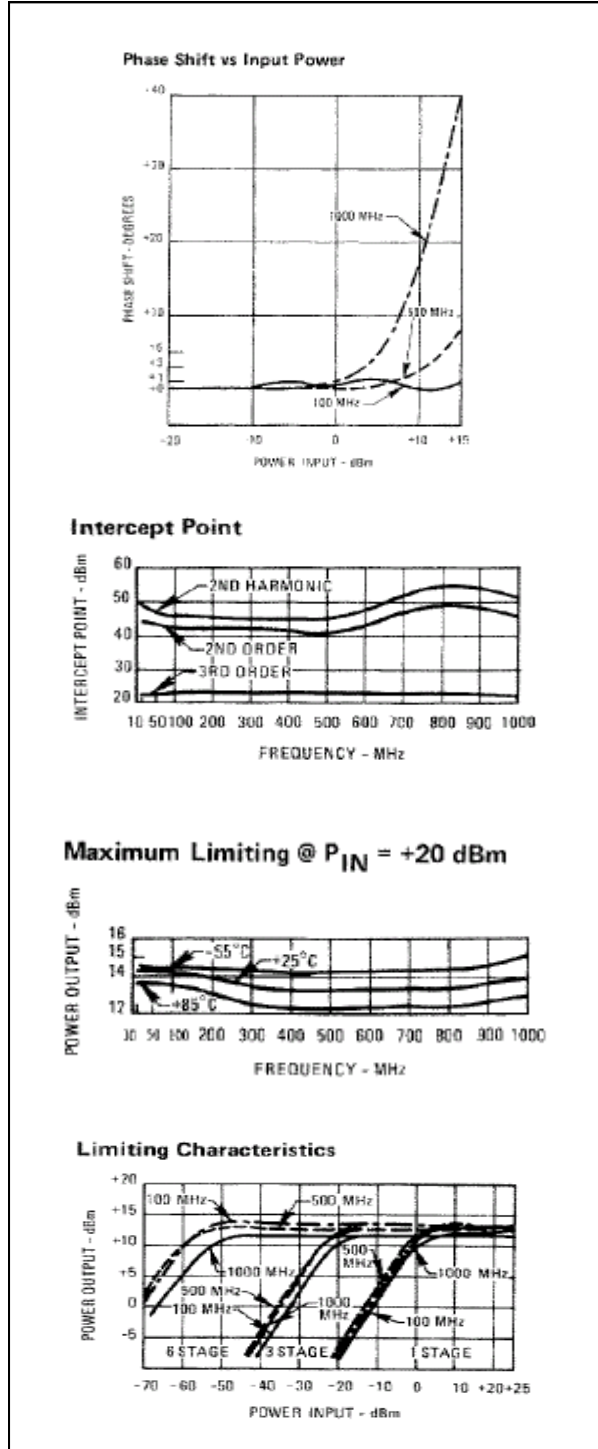

Outline Drawing: TO-8 *

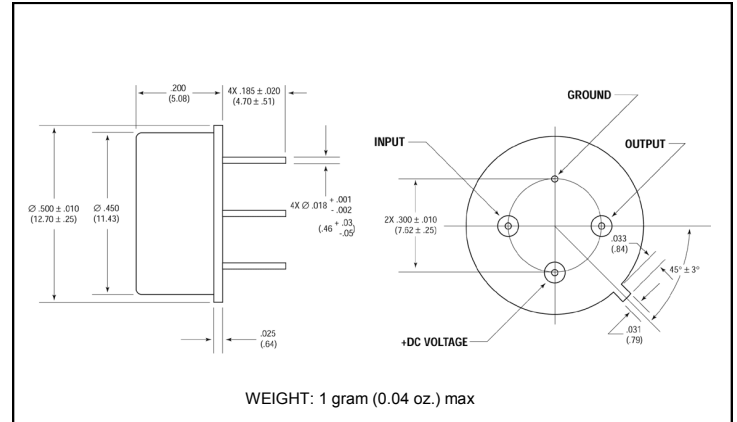

Outline Drawing: Surface Mount *

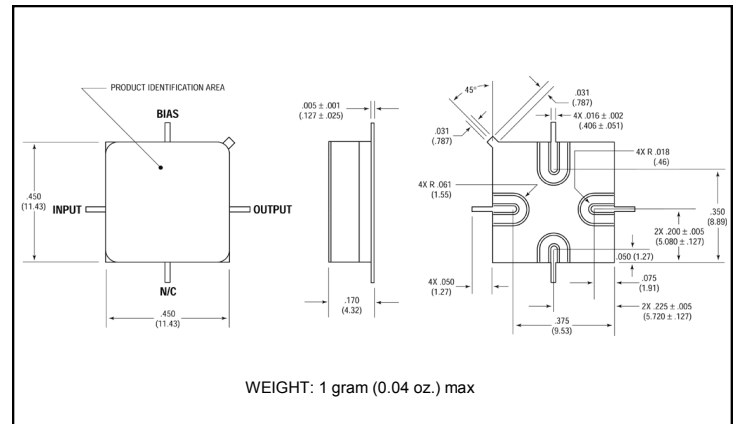

Outline Drawing: SMA Connectorized *

