

Limiting Amplifier 50 - 500 MHz

Rev. V2

Features

- SYMMETRICAL CLIPPING
GOOD EVEN-ORDER SUPPRESSION
- HIGH OUTPUT LEVEL: +11.5 dBm (TYP.)
- HIGH THIRD-ORDER IP: +28 dBm (TYP.)
- FAST PULSE RECOVERY TIME: < 50 NSEC (TYP.)

Description

The LA7 limiting amplifier is a discrete hybrid design, which uses thin film manufacturing processes for accurate performance and high reliability.

This design uses a Schottky diode limiter circuit at the input, and a single stage bipolar transistor feedback amplifier at the output. An RF choke is used for DC power supply decoupling. Both TO-8 and Surface Mount packages are hermetically sealed, and MIL-STD-883 environmental screening is available.

Product Image

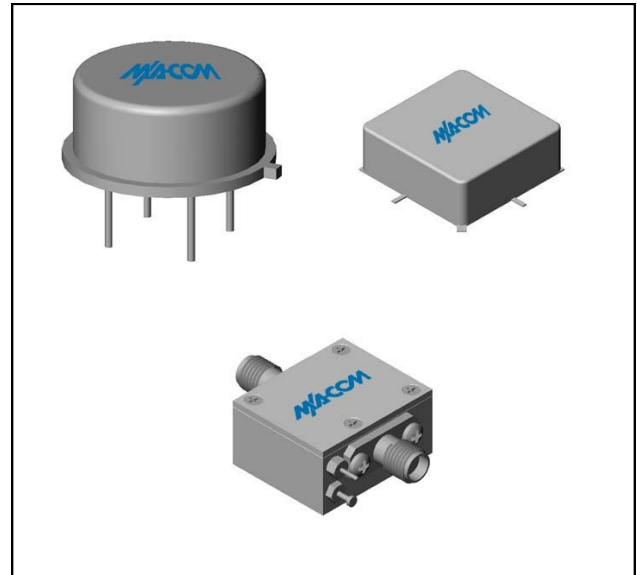

Ordering Information

Part Number	Package
LA7	TO-8
SMLA7	Surface Mount
CLA7 **	SMA Connectorized

** The connectorized version is not RoHs compliant.

Electrical Specifications: $Z_0 = 50\Omega$, $V_{CC} = +15 V_{DC}$

Parameter	Units	Typical	Guaranteed	
		25°C	0° to 50°C	-54° to +85°C*
Frequency	MHz	20-550	50-500	50-500
Small Signal Gain (min)	dB	12.5	12.0	11.0
Gain Flatness (max)	dB	±0.2	±0.5	±0.7
Noise Figure (max) 50-300 MHz	dB	7.0	8.0	8.5
Noise Figure (max) 300-500 MHz	dB	7.5	8.5	9.0
Power Output @ 1 dB comp. (min) 50-300 MHz	dBm	+12.0	+11.0	+8.0
Power Output @ 1 dB comp. (min) 300-500 MHz	dBm	+11.5	+10.0	+7.0
IP3	dBm	+28		
VSWR Input / Output (max)		1.3:1 / 1.3:1	1.7:1 / 1.7:1	2.0:1 / 2.0:1
DC Current @ 15 Volts (max)	mA	54	56	58

Absolute Maximum Ratings

Parameter	Absolute Maximum
Storage Temperature	-62°C to +125°C
Case Temperature	+125°C
DC Voltage	+17 V
Continuous Input Power	+23 dBm
Short Term Input power (1 minute max.)	400 mW
Peak Power (3 µsec max.)	1 W
"S" Series Burn-In Temperature (case)	+125°C

Thermal Data: $V_{CC} = +15 V_{DC}$

Parameter	Rating
Thermal Resistance θ_{jc}	45°C/W
Transistor Power Dissipation P_d	0.560 W
Junction Temperature Rise Above Case T_{jc}	+25.2°C

1 * Over temperature performance limits for part number CLA7, guaranteed from 0°C to +50°C only.

Limiting Amplifier 50 - 500 MHz

Rev. V2

Typical Performance Curves at +25°C

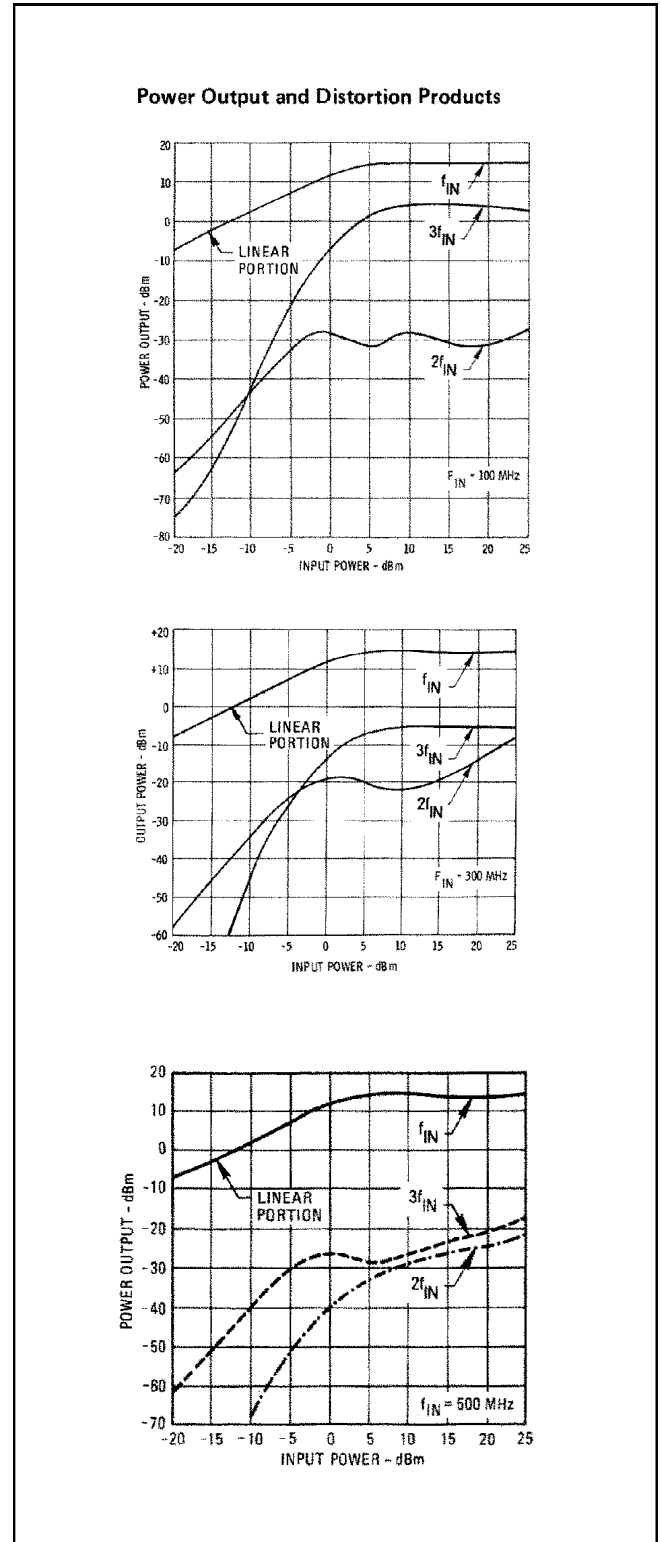
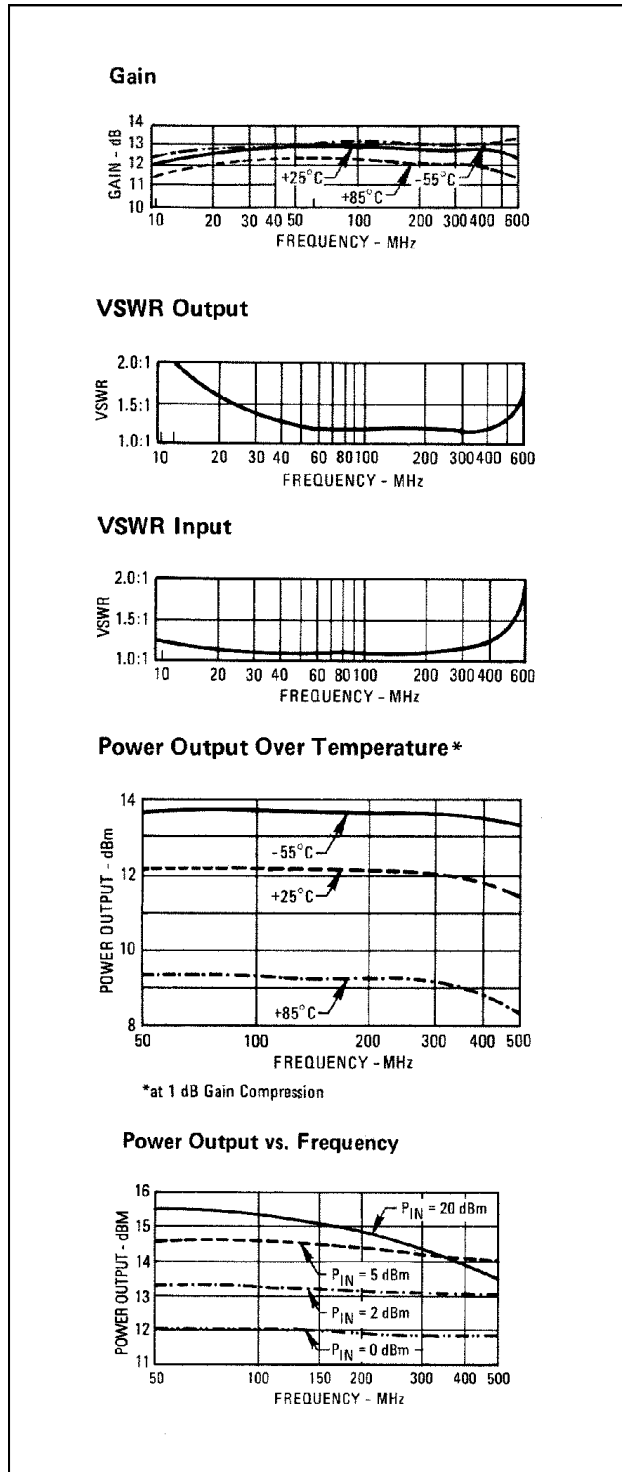

Limiting Amplifier 50 - 500 MHz

Rev. V2

Typical Performance Curves at +25°C

Phase Shift vs. Input Power

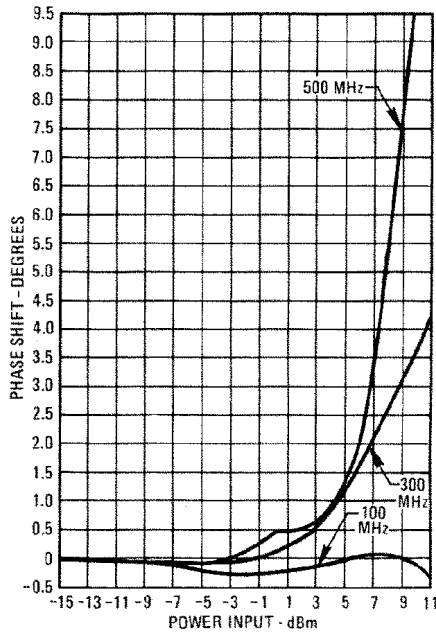

Limiting Characteristics

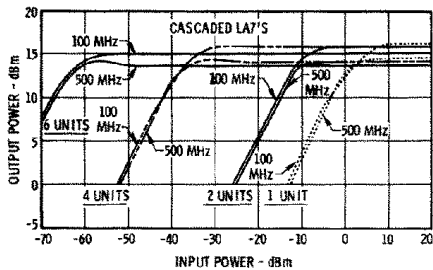

Schematic Diagram

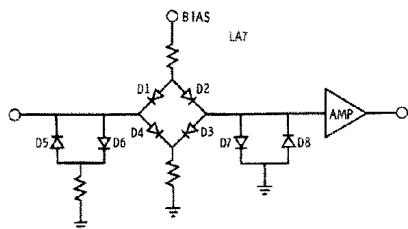

Outline Drawing: TO-8 *

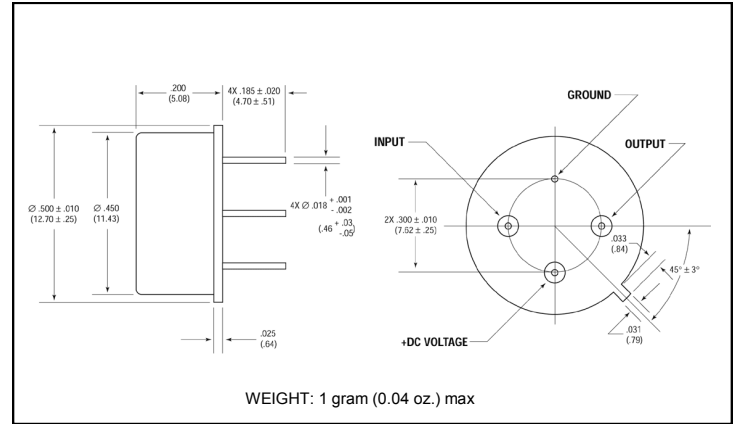

Outline Drawing: Surface Mount *

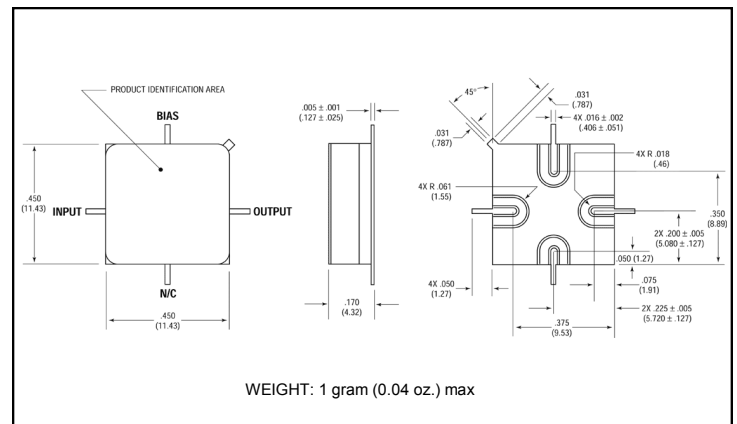

Outline Drawing: SMA Connectorized *

