

## 1 A ultra low-dropout LDO with bias

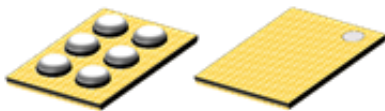

Flip Chip6 (0.8x1.2 mm)

### Features

- Input voltage from  $V_{OUT}$  to 5.5 V
- Input bias supply pin from 3.0 V to 5.5 V
- Ultra low-dropout voltage (40 mV typ. at 1 A load)
- Low ground current (35  $\mu$ A typ. at no load)
- Output voltage tolerance:  $\pm 1\%$  all over temperature range,  $\pm 0.5\%$  at 25 °C
- 1 A guaranteed output current
- 50 mV output voltage step available from 0.4 V to 1.8 V
- 100 mV output voltage step available from 1.9 V to 3.6 V
- Adjustable version from 0.5 V to 3.0 V
- Logic-controlled electronic shutdown
- Internal current limit
- Thermal shutdown
- Output active discharge function
- Available in Flip Chip6 (0.8x1.2 mm) package
- Temperature range: -40 °C to 85 °C

### Applications

- Smartphones
- Cameras
- Low voltage, low noise post regulation

Product status link

[LD57100](#)

### Description

The **LD57100** is a high accuracy voltage regulator, which provides 1 A of current. It is equipped with an NMOS pass transistor, whose gate is biased by a dedicated pin, thus allowing the ultra-low drop performance even at very low input voltages.

It is available in Flip Chip6 (0.8x1.2 mm), maximizing the space saving. This device is stabilized with a small ceramic capacitor on the output. The ultra low drop, low quiescent current and short-circuit protection make the **LD57100** suitable for low power battery-operated applications.

An enable logic control function puts the **LD57100** in shutdown mode allowing a total current consumption lower than 0.1  $\mu$ A. Thermal protection is also included.

# 1 Diagrams

Figure 1. Block diagram fixed version

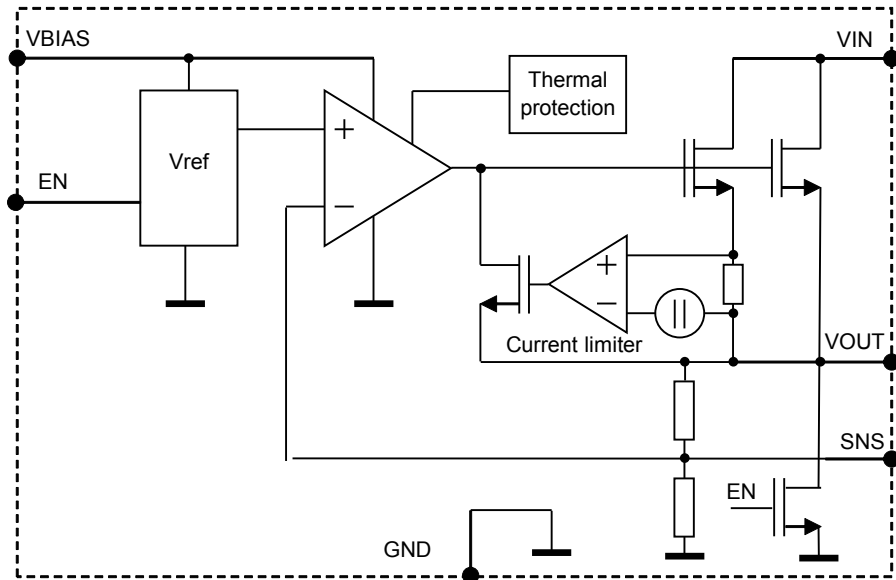
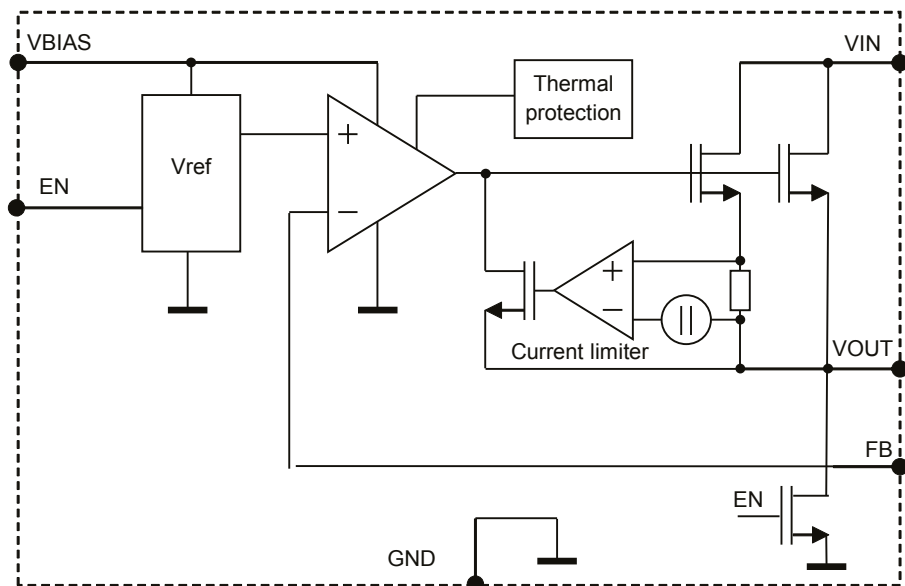
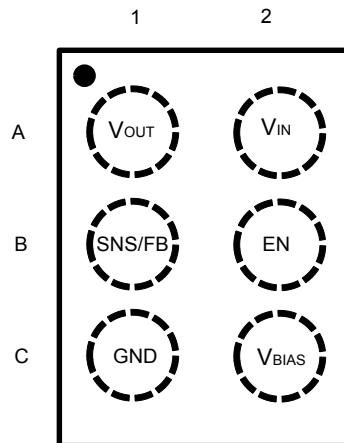

Figure 2. Block diagram adjustable version



## 2 Pin configuration

**Figure 3. Pin connection (top view)**



**Table 1. Pin description**

Pin #	Symbol	Functions
A1	$V_{OUT}$	Output voltage
A2	$V_{IN}$	Input voltage
B1	SNS / FB	Output voltage sense pin in fixed version. Connect to the load with a separate PCB track. Feedback pin in adjustable version. Connect to the resistor divider central node
B2	EN	Enable pin logic input: low = shutdown, high = active
C1	GND	Common ground
C2	$V_{BIAS}$	Bias supply input

### 3 Typical application circuits

Figure 4. Typical application for fixed version

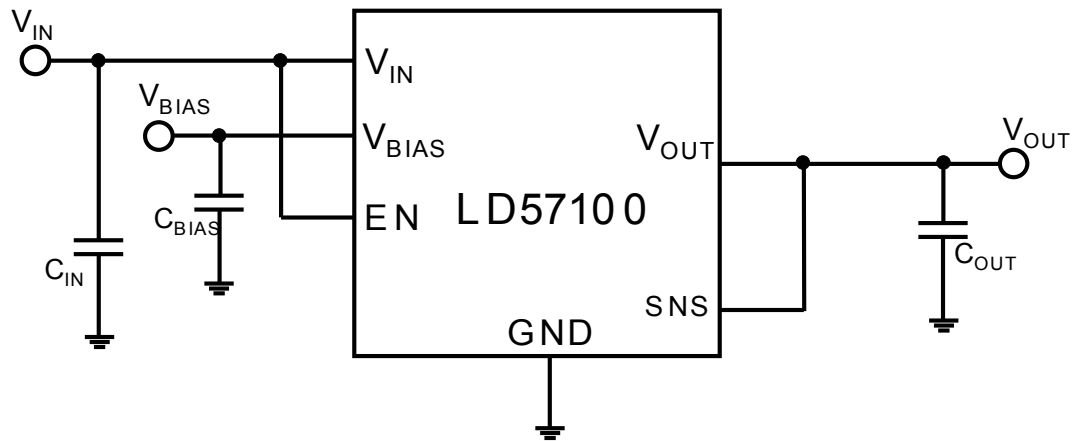

Figure 5. Typical application for adjustable version

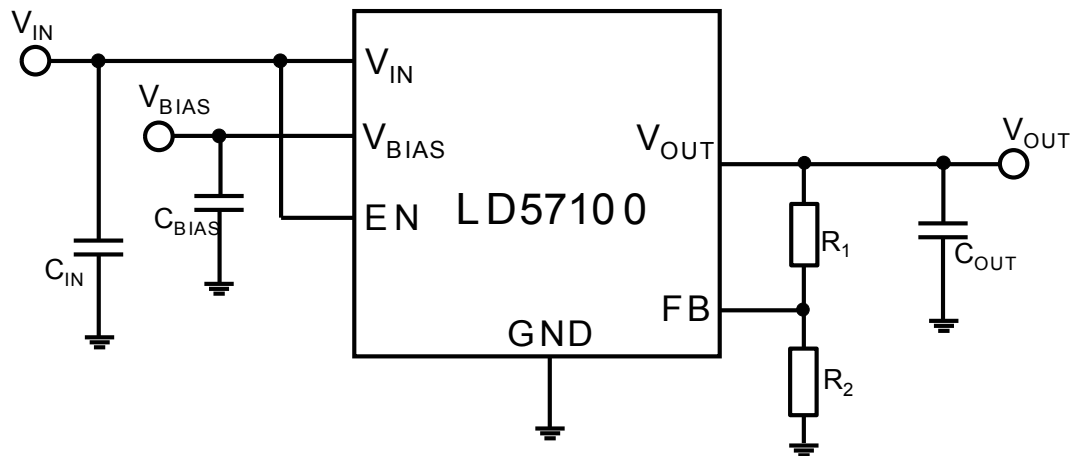

Table 2. Typical application components

Symbol	Value	Description	Note
$C_{IN}$	1 $\mu$ F	Input capacitor	Ceramic type
$C_{BIAS}$	4.7 $\mu$ F	Control logic bypass capacitor	Ceramic type
$C_{OUT}$	10 $\mu$ F	Output capacitor	Ceramic type
$R_1$		Output voltage side resistor	See Section 6.4 <a href="#">V<sub>OUT</sub> setting (adjustable version)</a>
$R_2$		Ground side resistor	<500 k $\Omega$ max.

## 4 Absolute maximum ratings

**Table 3. Absolute maximum ratings**

Symbol	Parameter	Value	Unit
$V_{IN}, V_{BIAS}$	Input voltage	-0.3 to 7	V
$V_{OUT}, V_{FB}, V_{SNS}$	Output voltage	-0.3 to $V_{IN} + 0.3$	V
$V_{EN}$	Enable input voltage	-0.3 to 7	V
$I_{OUT}$	Output current	Internally limited (see $I_{SC}$ in Table 6. Electrical characteristics)	A
$T_{STG}$	Storage temperature range	- 40 to 150	°C

*Note:* Absolute maximum ratings are those values beyond which damage to the device may occur. Functional operation under these conditions is not implied. All values are referred to GND.

**Table 4. Thermal data**

Symbol	Parameter	Value	Unit
$R_{thJA}$	Thermal resistance junction-ambient <sup>(1)</sup>	60	°C/W

1. We considered the STD JEDEC board 4 layers (2s2p) 101.5 x114.5 mm with a top copper plane of 4x4 mm.

**Table 5. ESD performance**

Symbol	Parameter	Test conditions	Value	Unit
ESD	ESD protection voltage	HBM	2	kV
		CDM	500	V

## 5 Electrical characteristics

$V_{BIAS} = 3.0\text{ V}$  or  $V_{OUT} + 1.6\text{ V}$  (whichever is greater);  $V_{IN} = V_{OUT(NOM)} + 0.3\text{ V}$ ;  $I_{OUT} = 1\text{ mA}$ ;  $C_{IN} = 4.7\text{ }\mu\text{F}$ ,  $C_{OUT} = 10\text{ }\mu\text{F}$ ;  $C_{BIAS} = 1\text{ }\mu\text{F}$ ,  $V_{EN} = 1\text{ V}$ ; typical values are at  $T_J = 25\text{ }^\circ\text{C}$ ; min./max. values are at  $-40\text{ }^\circ\text{C} \leq T_J \leq 85\text{ }^\circ\text{C}$ , unless otherwise specified.

**Table 6. Electrical characteristics**

Symbol	Parameter	Test conditions	Min.	Typ.	Max.	Unit
$V_{IN}$	Operating input voltage		$V_{OUT} + V_{DROP}$		5.5	V
$V_{BIAS}$	Operating bias voltage		$(V_{OUT} + 1.60) \geq 3.0$		5.5	V
$V_{UVLO}$	Bias undervoltage lockout	$V_{BIAS}$ rising $T_J = 25\text{ }^\circ\text{C}$	1.45	1.6	1.75	V
		Hysteresis $T_J = 25\text{ }^\circ\text{C}$	0.15	0.2	0.25	V
$V_{REF}$	Reference voltage for adjustable devices	$T_J = 25\text{ }^\circ\text{C}$ ;		0.5		V
$V_{OUT}$	Output voltage accuracy	All versions, as per conditions above		$\pm 0.5$		%
		$V_{OUT(NOM)} + 0.3\text{ V} \leq V_{IN} \leq V_{OUT(NOM)} + 1.0\text{ V}$ ; $3.0\text{ V}$ or $V_{OUT(NOM)} + 1.6\text{ V}$ (whichever is greater) $\leq V_{BIAS} \leq 5.5\text{ V}$ ; $I_{OUT} = 1\text{ mA}$ to $1\text{ A}$ ; $-40\text{ }^\circ\text{C} \leq T_J \leq 85\text{ }^\circ\text{C}$	-1.0		+1.0	%
$\Delta V_{OUT-IN}$	$V_{IN}$ static regulation	$V_{OUT(NOM)} + 0.3\text{ V} \leq V_{IN} \leq 5.0\text{ V}$ ; $T_J = 25\text{ }^\circ\text{C}$		0.01	0.1	% / V
$\Delta V_{OUT-BIAS}$	$V_{BIAS}$ line regulation	$3.0\text{ V}$ or $V_{OUT(NOM)} + 1.6\text{ V}$ (whichever is greater) $\leq V_{BIAS} \leq 5.5\text{ V}$ ; $T_J = 25\text{ }^\circ\text{C}$		0.01	0.1	% / V
$\Delta V_{OUT-LOAD}$	Static load regulation	$I_{OUT} = 1\text{ mA}$ to $1\text{ A}$ , $T_J = 25\text{ }^\circ\text{C}$		1.0	2.0	mV
$V_{DROP}$	Dropout voltage	$I_{OUT} = 1\text{ A}$ ; $V_{OUT} = 97\%$ of $V_{OUT(NOM)}$		40	80	mV
$V_{DROP-BIAS}$	Bias dropout voltage <sup>(1)</sup>	$V_{BIAS} = V_{IN}$ ; $I_{OUT} = 1\text{ A}$ ; $V_{OUT} = 97\%$ of $V_{OUT(NOM)}$		1.05	1.5	V
$I_{LIM}$	Output current limit	$V_{OUT} = 90\% V_{OUT(NOM)}$	1.5	2	2.6	A
		$V_{OUT} = 90\% V_{OUT(NOM)}$ , $-30\text{ }^\circ\text{C} \leq T_J \leq 85\text{ }^\circ\text{C}$	1.55	2	2.6	
$I_{FB}$ , $I_{SNS}$	FB/SNS pin operating current			0.1	0.5	$\mu\text{A}$
$I_{BIAS}$	$V_{BIAS}$ operating current	$V_{BIAS} = 3.0\text{ V}$ , $I_{OUT} = 0\text{ mA}$		35	50	$\mu\text{A}$
$I_{Standby-BIAS}$	$V_{BIAS}$ standby current	$V_{BIAS}$ input current in OFF mode: $V_{EN} = \text{GND}$		0.1	1	$\mu\text{A}$
$I_{Standby-IN}$	$V_{IN}$ standby current	$V_{IN}$ input current in OFF mode: $V_{EN} = \text{GND}$		0.1	1	$\mu\text{A}$
$V_{EN}$	Enable input logic low				0.4	V
	Enable input logic high		0.9			

Symbol	Parameter	Test conditions	Min.	Typ.	Max.	Unit
$I_{EN}$	Enable pin input current	$V_{EN} = V_{BIAS} = 5.5\text{ V}$		0.2	1	$\mu\text{A}$
$T_{ON}$	Turn-on time	From assertion of $V_{EN}$ to $V_{OUT} = 98\% V_{OUT(NOM)}$ , $V_{OUT(NOM)} = 1.0\text{ V}$		160		$\mu\text{s}$
$SVR_{IN-ADJ}$	$V_{IN}$ supply voltage rejection (adj version)	$V_{IN} = V_{OUT(NOM)} + 0.5\text{ V} \pm V_{RIPPLE}$ $V_{RIPPLE} = 0.2\text{ V}$ ; freq=1 kHz $I_{OUT} = 10\text{ mA}$ ; $V_{OUT(NOM)} = 1.0\text{ V}$		70		dB
$SVR_{BIAS-ADJ}$	$V_{BIAS}$ supply voltage rejection (adj version)	$V_{BIAS} = 3.0\text{ V} \pm V_{RIPPLE}$ , $V_{RIPPLE} = 0.2\text{ V}$ ; freq=1 kHz; $V_{IN} = V_{OUT(NOM)} + 0.5\text{ V}$ $I_{OUT} = 10\text{ mA}$ ; $V_{OUT(NOM)} = 1.0\text{ V}$		85		dB
$e_{N-ADJ}$	Output noise voltage (adj version)	$V_{IN} = V_{OUT(NOM)} + 0.5\text{ V}$ ; $V_{OUT(NOM)} = 1.0\text{ V}$ ; 10 Hz to 100 kHz, $I_{OUT} = 1\text{ mA}$		$35 \times V_{OUT} / V_{REF}$		$\mu\text{V}_{RMS}$
$SVR_{IN-FIX}$	$V_{IN}$ supply voltage rejection (adj version)	$V_{IN} = V_{OUT(NOM)} + 0.5\text{ V} \pm V_{RIPPLE}$ $V_{RIPPLE} = 0.2\text{ V}$ ; freq=1 kHz $I_{OUT} = 10\text{ mA}$ ; $V_{OUT(NOM)} = 1.8\text{ V}$		75		dB
$SVR_{BIAS-FIX}$	$V_{BIAS}$ supply voltage rejection (fixed versions)	$V_{BIAS} = 4.0\text{ V} \pm V_{RIPPLE}$ $V_{RIPPLE} = 0.2\text{ V}$ ; freq=1 kHz; $V_{IN} = V_{OUT(NOM)} + 0.5\text{ V}$ $I_{OUT} = 10\text{ mA}$ ; $V_{OUT(NOM)} = 1.8\text{ V}$		85		dB
$e_{N-FIX}$	Output noise voltage (fixed versions)	$V_{IN} = V_{OUT(NOM)} + 0.5\text{ V}$ ; $V_{OUT(NOM)} = 1.0\text{ V}$ ; 10 Hz to 100 kHz, $I_{OUT} = 1\text{ mA}$		27		$\mu\text{V}_{RMS}$
$R_{ON}$	Output voltage discharge MOSFET			150		$\Omega$
$T_{SHDN}$	Thermal shutdown			160		$^{\circ}\text{C}$
	Hysteresis			20		

1. Not applicable to fixed versions with  $V_{OUT(NOM)} < 2.0\text{ V}$ .

## 6 Application information

### 6.1 $V_{BIAS}$ pin voltage requirements

The bias input is the supply of the internal driving and control circuitry. In order to assure a proper biasing of the N-channel power element, the bias pin must have a minimum voltage of 3.0 V and be 1.6 V (typically) higher than the output. If  $V_{IN}$  supply voltage meets these requirements then the bias pin can be tied to  $V_{IN}$ .

### 6.2 Output discharge function

The LD57100 integrates a MOSFET connected between  $V_{OUT}$  and GND. This transistor is activated when the EN pin goes to low logic level and has the function to quickly discharge the output capacitor when the device is disabled by the user.

### 6.3 Short-circuit and current limitation

The LD57100 is protected against short-circuit on the output. The load current is limited to the maximum value of  $I_{LIM}$  when  $V_{OUT}$  is equal to 90% of its nominal value.

### 6.4 $V_{OUT}$ setting (adjustable version)

In the LD57100 adjustable version, the desired output voltage is set according to the formula below:

$$V_{OUT} = V_{REF} \times \left(1 + \frac{R_1}{R_2}\right) \quad (1)$$

where  $R_2$  cannot be higher than 500 k $\Omega$ .

Please, refer to [Figure 5. Typical application for adjustable version](#) for  $R_1$  and  $R_2$  connections.

### 6.5 Thermal protection

Thermal protection works when the junction temperature reaches 160 °C typical. At this point, the output of the IC shuts down. As soon as the junction temperature falls below the thermal hysteresis value, the device starts working again.

In order to calculate the maximum power that the device can dissipate, keeping the junction temperature below the maximum operating value, the following formula is used:

$$P_{DMAX} = (85 - T_{AMB}) / R_{thJA} \quad (2)$$

### 6.6 Input and output capacitors

The LD57100 requires external capacitors to assure the regulator control loop stability.

Any good quality ceramic capacitor can be used, however the X5R and the X7R are suggested since they guarantee a very stable combination of capacitance and ESR all over the temperature range.

It is recommended to place the input/output capacitors as close as possible to the relative pins. The LD57100 requires a  $V_{IN}$  capacitor with a minimum value of 1  $\mu$ F and a  $V_{BIAS}$  capacitor of 100 nF minimum. These capacitors must be placed as close as possible to the input pins of the device and returned to a clean analog ground.

The control loop is designed to be stable with any good quality output ceramic capacitor (such as: X5R/X7R types) with a minimum value of 1.0  $\mu$ F and equivalent series resistance in the [3 – 300 m $\Omega$ ] range. It is important to highlight that the output capacitor must maintain its capacitance and ESR in the stable region over the full operating temperature, load and input voltage ranges, to assure stability. Therefore, capacitance and ESR variations must be taken into account in the design phase to be sure that the device works in the expected stability region.



## 7 Typical characteristics

$C_{IN} = 1 \mu\text{F}$ ;  $C_{OUT} = 10 \mu\text{F}$ ,  $T_J = 25 \text{ }^\circ\text{C}$  unless otherwise specified.

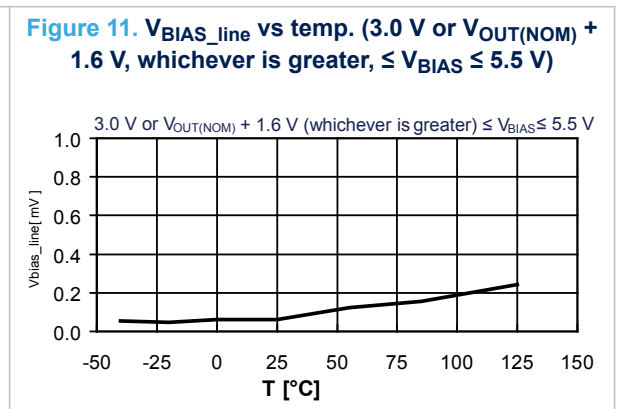
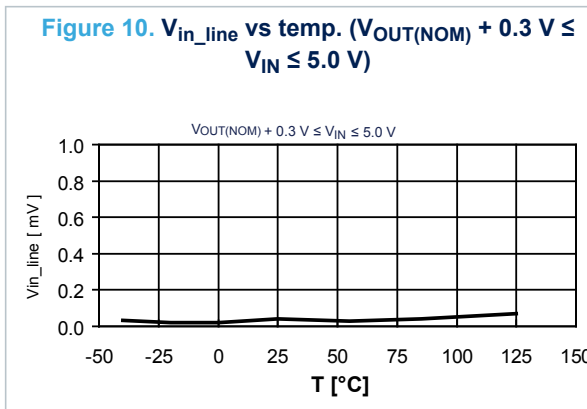
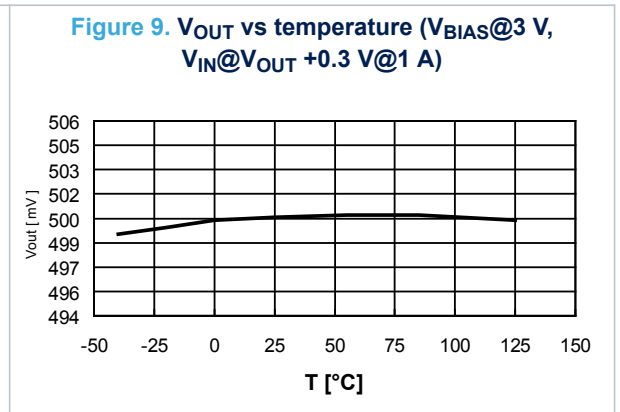
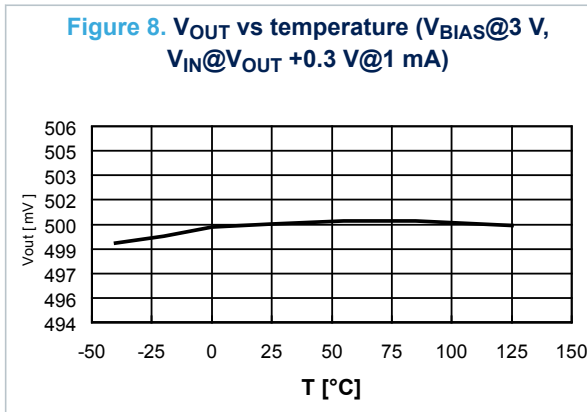
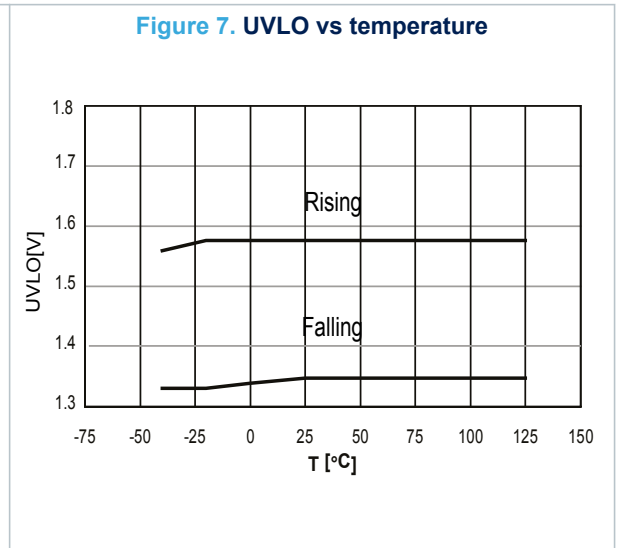
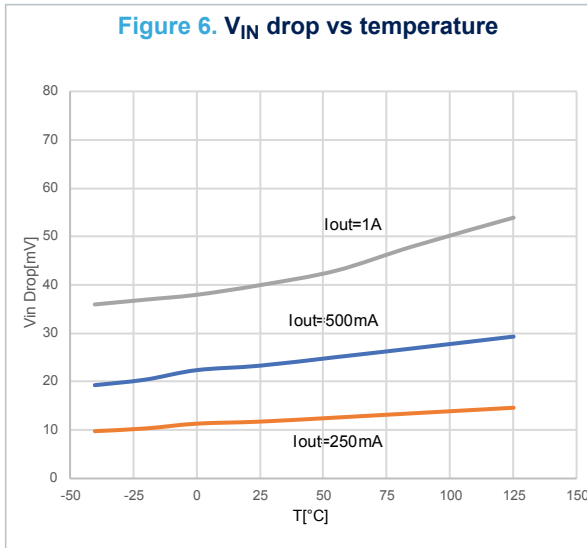

Figure 12. Load vs temperature

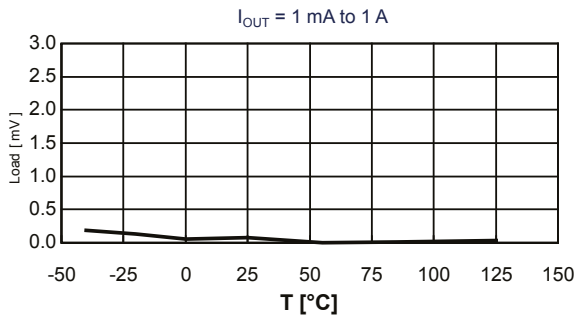

Figure 13.  $I_{SENSE}$  vs temperature

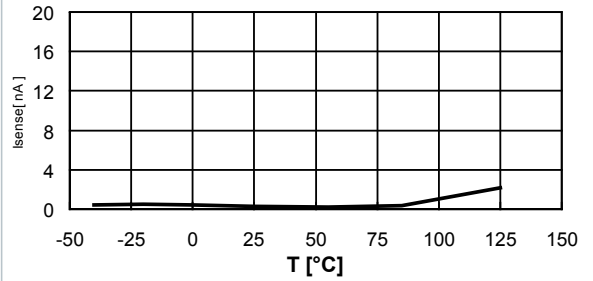

Figure 14.  $I_{BIAS}$  vs temperature

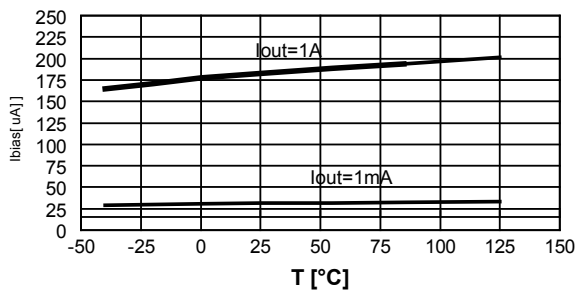

Figure 15. Enable high vs temperature ( $V_{BIAS \text{ min.}}$ )

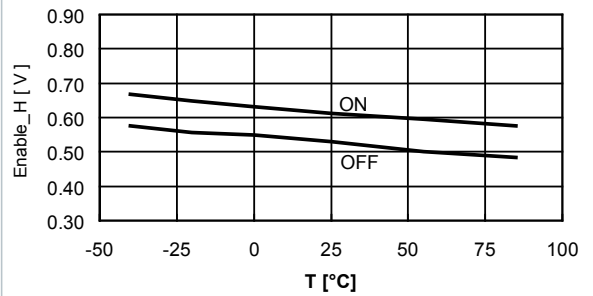

Figure 16.  $I_{ENABLE}$  vs temperature

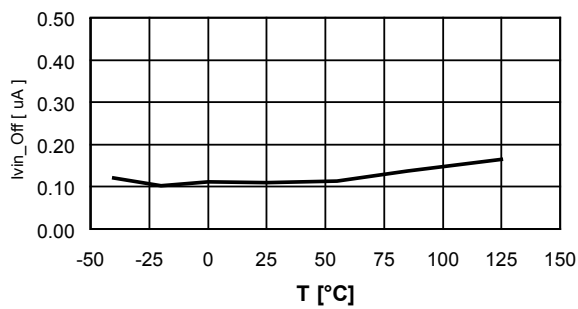
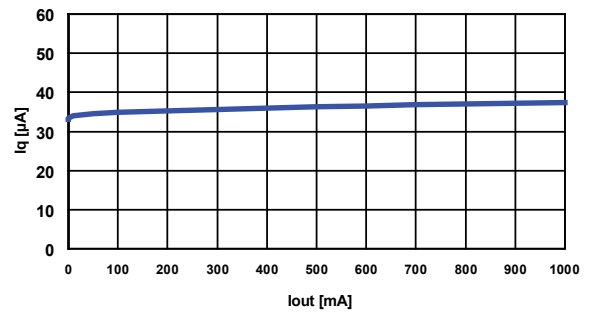
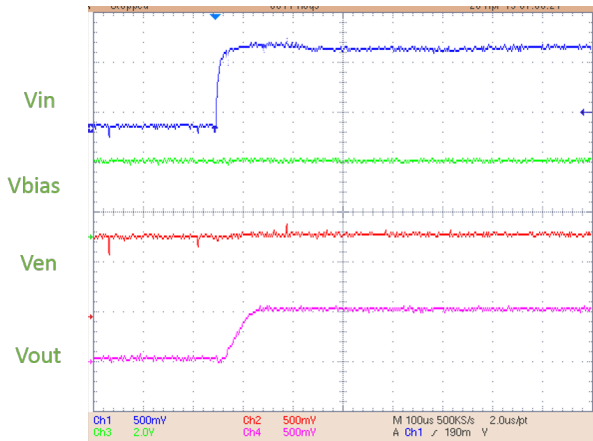

Figure 17. Ground pin current vs load current



$V_{OUT} = 0.5\text{ V}$ ,  $C_{IN} = 4.7\ \mu\text{F}$ ,  $C_{OUT} = 10\ \mu\text{F}$ ,  $C_{BIAS} = 1\ \mu\text{F}$ ,  $t_{rise/fall} = 5\ \mu\text{s}$

**Figure 18. Input voltage turn-on ( $V_{IN}$ = from 0 V to 0.8 V,  $V_{BIAS}$ =3 V,  $V_{EN}$ =0.8 V,  $I_{OUT}$ =1 A)**



**Figure 19. Load transient ( $V_{IN}$ =0.8 V,  $V_{BIAS}$ =3 V,  $V_{EN}$ =1 V,  $I_{OUT}$  from 1 mA to 1 A)**

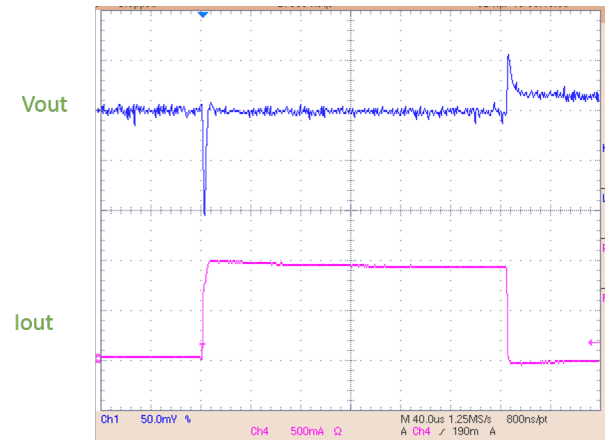

**Figure 20. Line transient vs input voltage ( $V_{IN}$ = from 0.8 V to 1.08 V,  $V_{BIAS}$ =3 V,  $V_{EN}$ =1 V,  $I_{OUT}$  100 mA)**

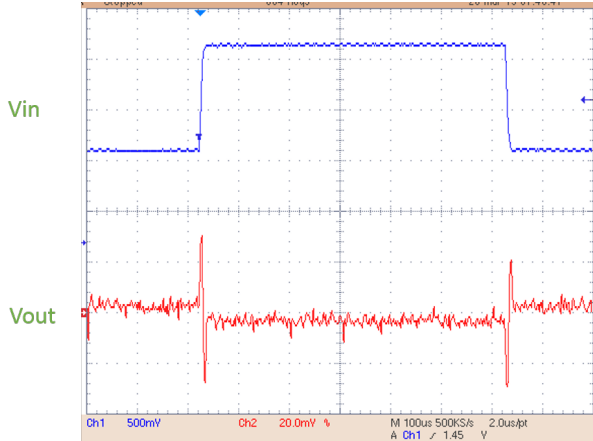

**Figure 21. Line transient vs BIAS voltage ( $V_{IN}$ =0.8 V to 1.08 V,  $V_{BIAS}$ = from 2.8 to 3.8 V,  $V_{EN}$ =1 V,  $I_{OUT}$ =100 mA)**

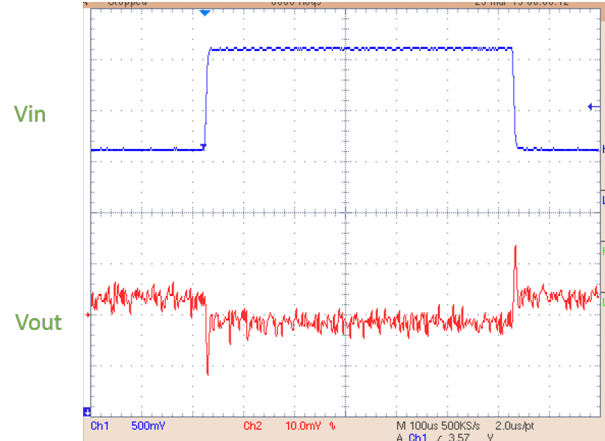

**Figure 22.  $V_{BIAS}$  PSRR vs frequency**

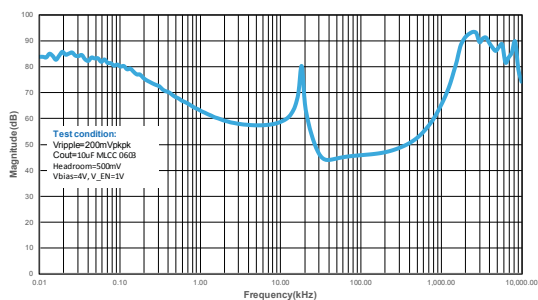

**Figure 23.  $V_{IN}$  PSRR vs frequency**

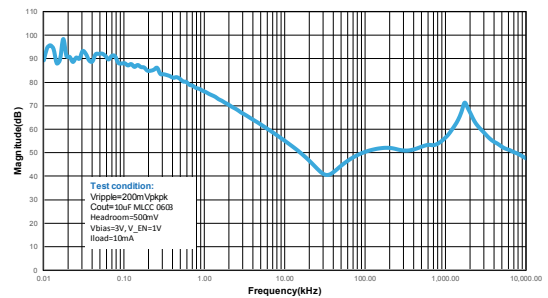

Figure 24. Output voltage spectral noise density vs frequency ( $V_{OUT} = 1\text{ V adj.}$ )

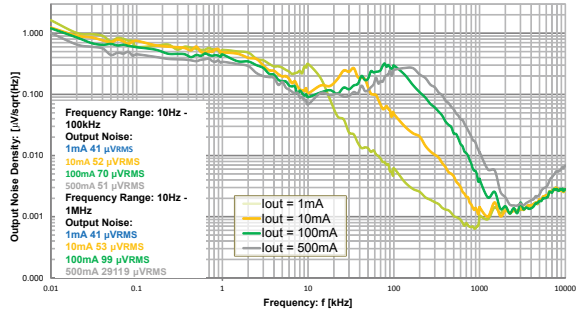

Figure 25. Output voltage spectral noise density vs frequency

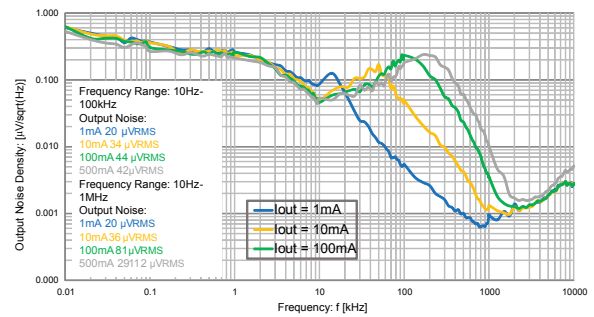
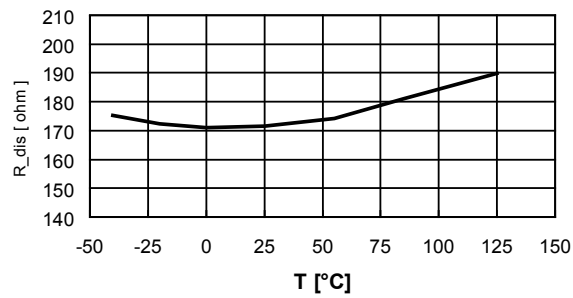

Figure 26. Discharge\_R MOS vs temperature



## 8 Package information

In order to meet environmental requirements, ST offers these devices in different grades of **ECOPACK** packages, depending on their level of environmental compliance. ECOPACK specifications, grade definitions and product status are available at: [www.st.com](http://www.st.com). ECOPACK is an ST trademark.

### 8.1 Flip Chip6 (0.8x1.2 mm) package information

Figure 27. Flip Chip6 (0.8x1.2 mm) package outline

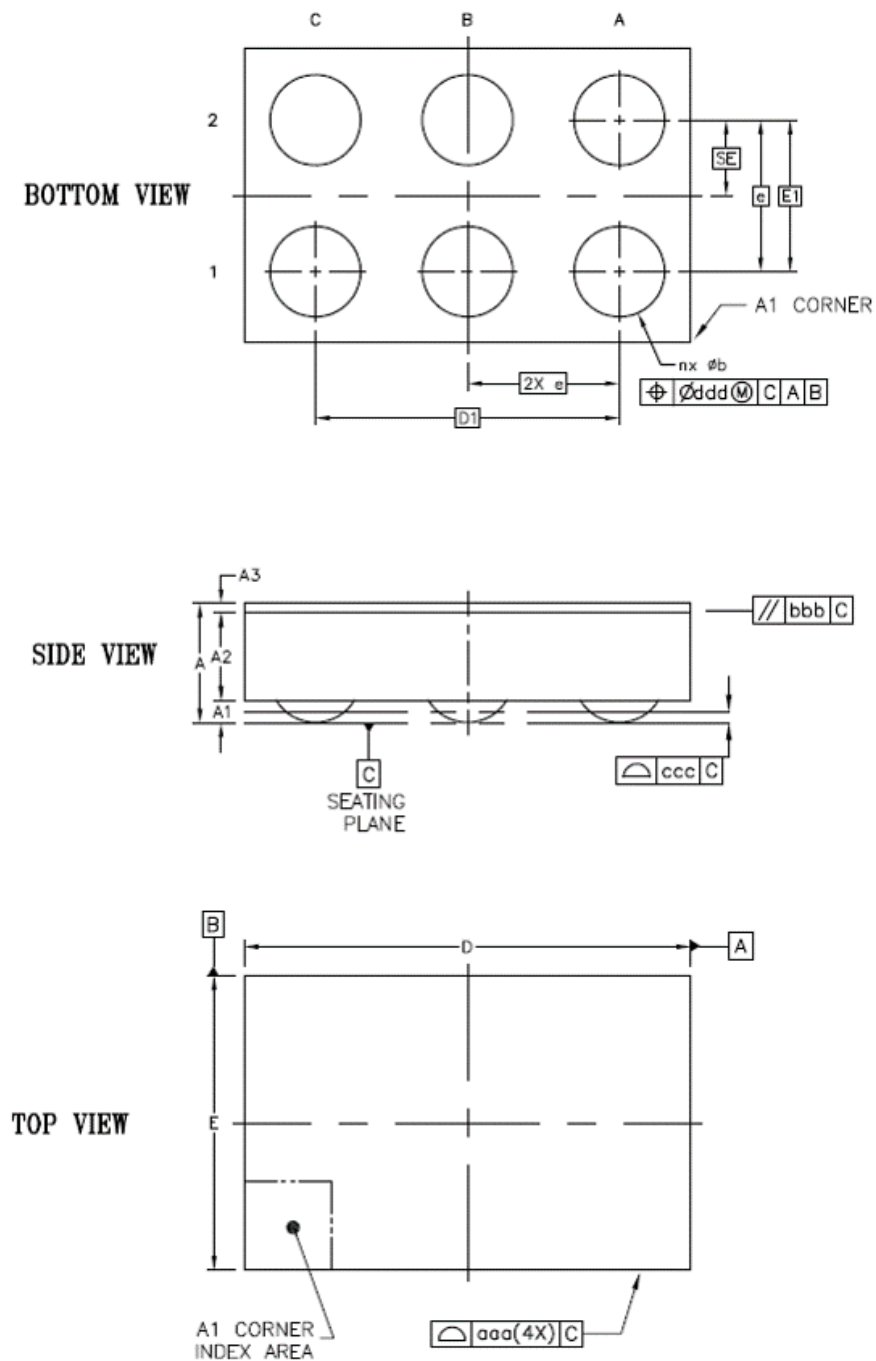

**Table 7. Flip Chip6 (0.8x1.2 mm) package mechanical data**

Symbol	Millimeters		
	Min.	Typ.	Max.
A	0.277	0.315	0.361
A1	0.045	0.060	0.075
A2	0.205	0.230	0.255
A3	0.022	0.025	0.028
b	0.210	0.240	0.270
D	1.155	1.175	1.195
E	0.755	0.775	0.795
D1	0.8 BSC		
E1	0.4 BSC		
e	0.4 BSC		
SE	0.2 BSC		
aaa	0.03		
bbb	0.06		
ccc	0.03		
ddd	0.015		

**Figure 28. Flip Chip6 (0.8x1.2 mm) recommended footprint**

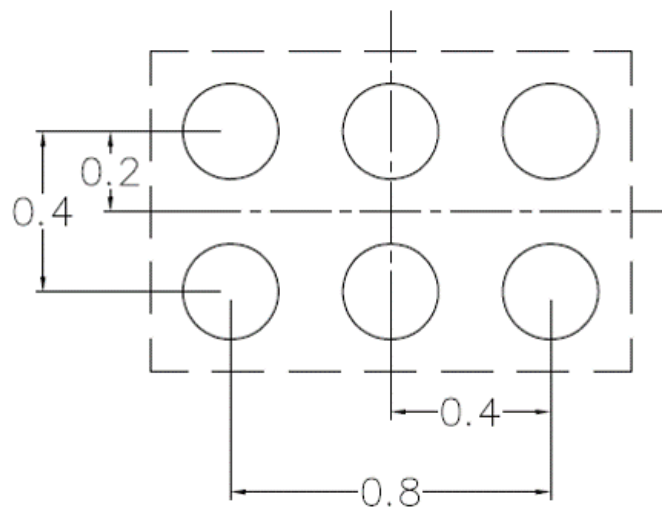

## 8.2 Flip Chip6 (0.8x1.2 mm) packing information

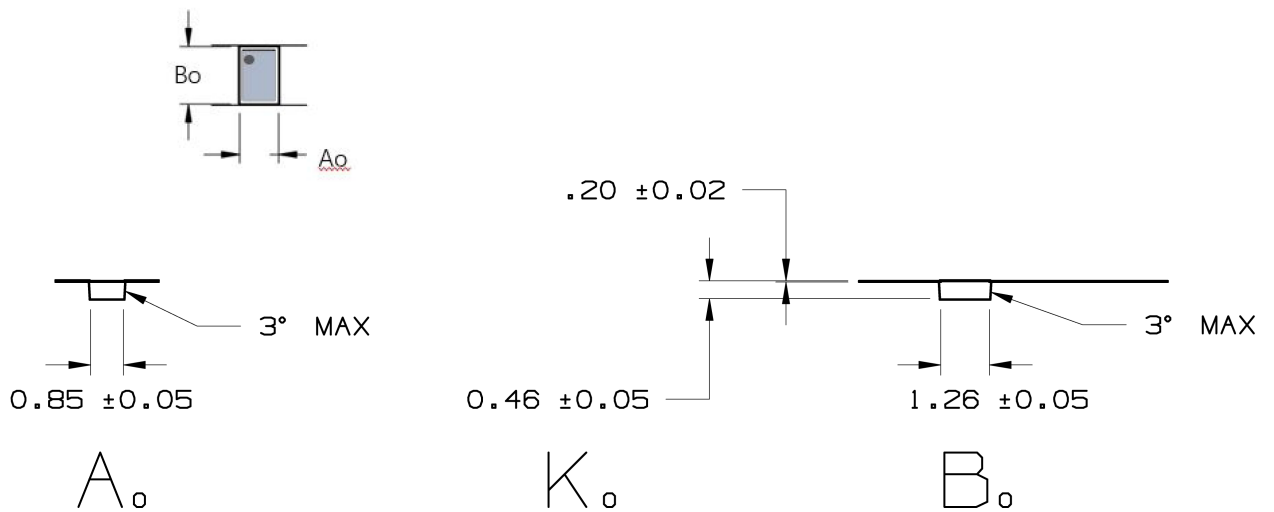
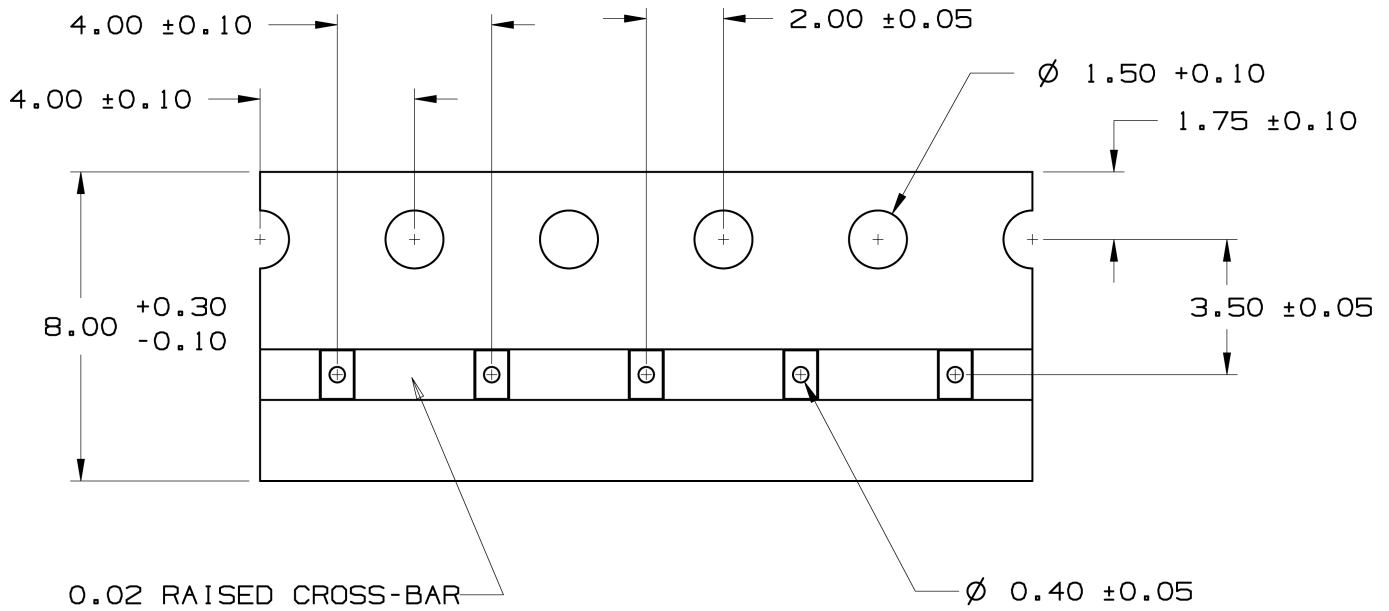
**Figure 29. Flip Chip6 (0.8x1.2 mm) carrier tape outline**

## 9 Ordering information

**Table 8. Order codes**

Order code	V <sub>OUT</sub>	Marking
LD57100J100R	1.00 V	JB
LD57100J105R	1.05 V	JC
LD57100J800R	0.8 V	JF
LD57100J110R	1.10 V	JD
LD57100JR	Adjustable	JA



## Revision history

**Table 9. Document revision history**

Date	Version	Changes
30-Oct-2019	1	Initial release.
20-Dec-2019	2	Updated <a href="#">Figure 2. Block diagram adjustable version</a> , <a href="#">Figure 22. V<sub>BIAS</sub> PSRR vs frequency</a> and <a href="#">Figure 23. V<sub>IN</sub> PSRR vs frequency</a> . Updated <a href="#">Table 3. Absolute maximum ratings</a> and <a href="#">Table 6. Electrical characteristics</a> .
20-Jan-2020	3	Updated <a href="#">Table 6. Electrical characteristics</a> and <a href="#">Table 8. Order codes</a> .

## Contents

<b>1</b>	<b>Diagrams</b> .....	<b>2</b>
<b>2</b>	<b>Pin configuration</b> .....	<b>3</b>
<b>3</b>	<b>Typical application circuits</b> .....	<b>4</b>
<b>4</b>	<b>Absolute maximum ratings</b> .....	<b>5</b>
<b>5</b>	<b>Electrical characteristics</b> .....	<b>6</b>
<b>6</b>	<b>Application information</b> .....	<b>8</b>
6.1	V <sub>BIAS</sub> pin voltage requirements .....	8
6.2	Output discharge function .....	8
6.3	Short-circuit and current limitation .....	8
6.4	V <sub>OUT</sub> setting (adjustable version) .....	8
6.5	Thermal protection .....	8
6.6	Input and output capacitors .....	8
<b>7</b>	<b>Typical characteristics</b> .....	<b>9</b>
<b>8</b>	<b>Package information</b> .....	<b>13</b>
8.1	Flip Chip6 (0.8x1.2 mm) package information .....	13
8.2	Flip Chip6 (0.8x1.2 mm) packing information .....	14
<b>9</b>	<b>Ordering information</b> .....	<b>16</b>
	<b>Revision history</b> .....	<b>17</b>

## List of tables

<b>Table 1.</b>	Pin description . . . . .	3
<b>Table 2.</b>	Typical application components . . . . .	4
<b>Table 3.</b>	Absolute maximum ratings . . . . .	5
<b>Table 4.</b>	Thermal data . . . . .	5
<b>Table 5.</b>	ESD performance . . . . .	5
<b>Table 6.</b>	Electrical characteristics . . . . .	6
<b>Table 7.</b>	Flip Chip6 (0.8x1.2 mm) package mechanical data . . . . .	14
<b>Table 8.</b>	Order codes . . . . .	16
<b>Table 9.</b>	Document revision history . . . . .	17

## List of figures

<b>Figure 1.</b>	Block diagram fixed version . . . . .	2
<b>Figure 2.</b>	Block diagram adjustable version . . . . .	2
<b>Figure 3.</b>	Pin connection (top view) . . . . .	3
<b>Figure 4.</b>	Typical application for fixed version . . . . .	4
<b>Figure 5.</b>	Typical application for adjustable version . . . . .	4
<b>Figure 6.</b>	$V_{IN}$ drop vs temperature. . . . .	9
<b>Figure 7.</b>	UVLO vs temperature . . . . .	9
<b>Figure 8.</b>	$V_{OUT}$ vs temperature ( $V_{BIAS}@3\text{ V}$ , $V_{IN}@V_{OUT} +0.3\text{ V}@1\text{ mA}$ ) . . . . .	9
<b>Figure 9.</b>	$V_{OUT}$ vs temperature ( $V_{BIAS}@3\text{ V}$ , $V_{IN}@V_{OUT} +0.3\text{ V}@1\text{ A}$ ) . . . . .	9
<b>Figure 10.</b>	$V_{in\_line}$ vs temp. ( $V_{OUT(NOM)} + 0.3\text{ V} \leq V_{IN} \leq 5.0\text{ V}$ ) . . . . .	9
<b>Figure 11.</b>	$V_{BIAS\_line}$ vs temp. ( $3.0\text{ V}$ or $V_{OUT(NOM)} + 1.6\text{ V}$ , whichever is greater, $\leq V_{BIAS} \leq 5.5\text{ V}$ ) . . . . .	9
<b>Figure 12.</b>	Load vs temperature . . . . .	10
<b>Figure 13.</b>	$I_{SENSE}$ vs temperature . . . . .	10
<b>Figure 14.</b>	$I_{BIAS}$ vs temperature . . . . .	10
<b>Figure 15.</b>	Enable high vs temperature ( $V_{BIAS}$ min.) . . . . .	10
<b>Figure 16.</b>	$I_{ENABLE}$ vs temperature . . . . .	10
<b>Figure 17.</b>	Ground pin current vs load current . . . . .	10
<b>Figure 18.</b>	Input voltage turn-on ( $V_{IN} =$ from $0\text{ V}$ to $0.8\text{ V}$ , $V_{BIAS}=3\text{ V}$ , $V_{EN}=0.8\text{ V}$ , $I_{OUT}=1\text{ A}$ ) . . . . .	11
<b>Figure 19.</b>	Load transient ( $V_{IN}=0.8\text{ V}$ , $V_{BIAS}=3\text{ V}$ , $V_{EN}=1\text{ V}$ , $I_{OUT}$ from $1\text{ mA}$ to $1\text{ A}$ ) . . . . .	11
<b>Figure 20.</b>	Line transient vs input voltage ( $V_{IN} =$ from $0.8\text{ V}$ to $1.08\text{ V}$ , $V_{BIAS}=3\text{ V}$ , $V_{EN}=1\text{ V}$ , $I_{OUT} 100\text{ mA}$ ). . . . .	11
<b>Figure 21.</b>	Line transient vs BIAS voltage ( $V_{IN}=0.8\text{ V}$ to $1.08\text{ V}$ , $V_{BIAS} =$ from $2.8$ to $3.8\text{ V}$ , $V_{EN}=1\text{ V}$ , $I_{OUT}=100\text{ mA}$ ) . . . . .	11
<b>Figure 22.</b>	$V_{BIAS}$ PSRR vs frequency . . . . .	11
<b>Figure 23.</b>	$V_{IN}$ PSRR vs frequency . . . . .	11
<b>Figure 24.</b>	Output voltage spectral noise density vs frequency ( $V_{OUT}= 1\text{ V adj.}$ ) . . . . .	12
<b>Figure 25.</b>	Output voltage spectral noise density vs frequency . . . . .	12
<b>Figure 26.</b>	Discharge_RMOS vs temperature. . . . .	12
<b>Figure 27.</b>	Flip Chip6 (0.8x1.2 mm) package outline . . . . .	13
<b>Figure 28.</b>	Flip Chip6 (0.8x1.2 mm) recommended footprint. . . . .	14
<b>Figure 29.</b>	Flip Chip6 (0.8x1.2 mm) carrier tape outline . . . . .	15