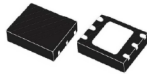


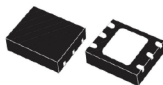
## High PSRR, low drop linear regulator IC



SO-8



DFN6 (2x2)



DFN6 (3x3)

### Features

- Input voltage from 2.5 V to 18 V
- 20 V AMR
- Any fixed output voltages, from 1.2 V to 12 V in 100 mV steps (from 1.2 V to 6.6 V in 50 mV steps) available on request
- Adjustable version from 1.18 V to  $V_{IN} - V_{DROP(MAX)}$
- Guaranteed output current 1.2 A
- Typical dropout 350 mV @ 1.2 A
- Undervoltage lockout
- Enable function
- Internal thermal, current and power limitation
- High PSRR: 87 dB @ 120 Hz, 75 dB @ 1 kHz
- Operating temperature range: -40 °C to 125 °C
- Packages SO-8 batwing plastic micropackage, DFN6 (3x3) and DFN6 (2x2)

### Applications

- Consumer
- Industrial
- SMPS
- Point-of-load
- DC-DC post-regulation

Maturity status link

LDL212

### Description

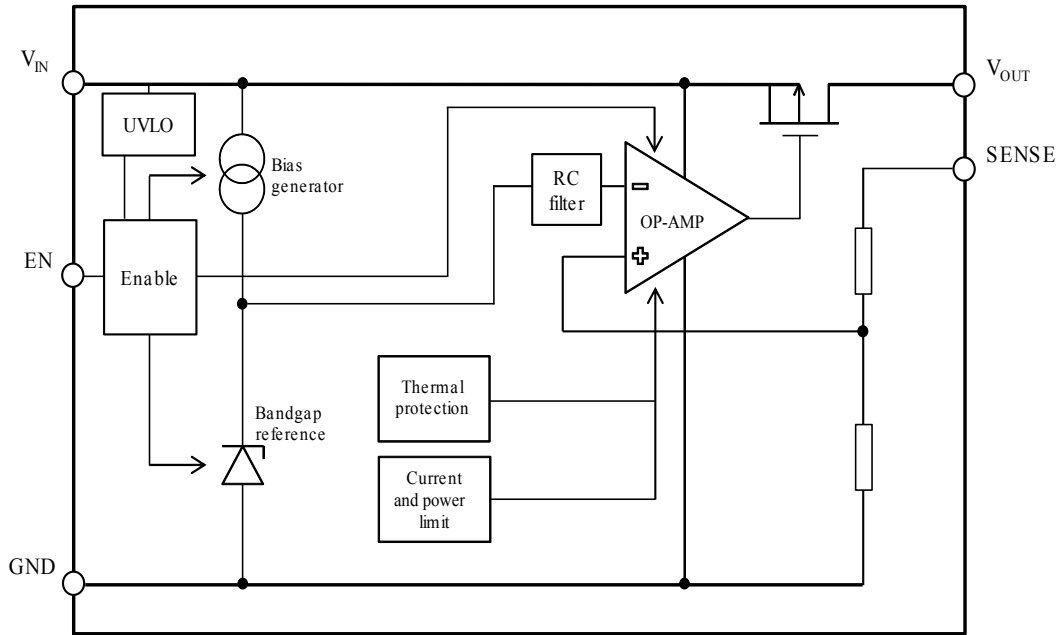
The **LDL212** provides 1.2 A of maximum current from an input voltage range from 2.5 V to 18 V, with a typical dropout voltage of 350 mV @ 1.2 A.

The high power supply rejection ratio of 87 dB at 120 Hz, and more than 40 dB at 100 kHz, makes the **LDL212** suitable for direct regulation in SMPS and secondary linear regulation in DC-DC converters. The **LDL212** goes to shutdown mode due to the enable logic control function, reducing the total current consumption.

The device also includes the current limit, SOA and thermal protections.

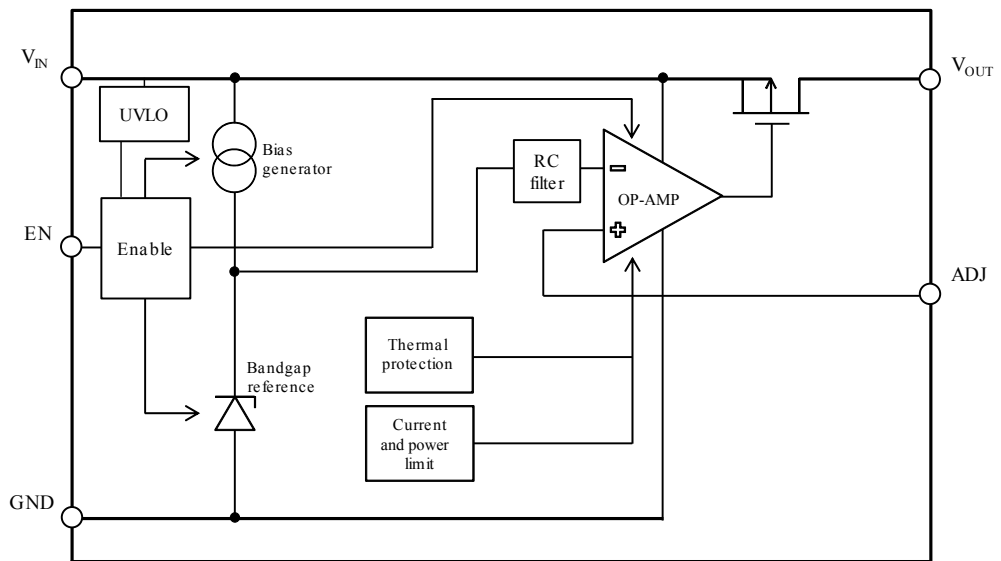
# 1 Block diagram

Figure 1. Block diagram (fixed)



GIPD251120151438MT

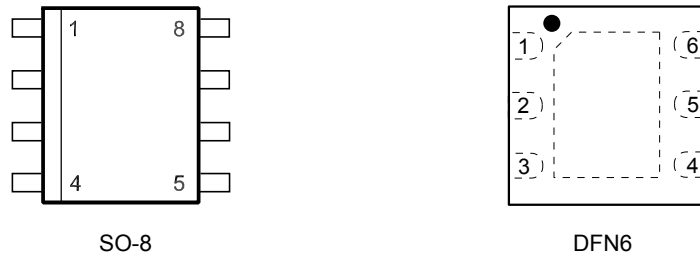
Figure 2. Block diagram (adjustable)



GIPD251120151438bMT

## 2 Pin configuration

Figure 3. Pin configuration (top view)



GIPD261120151015MT

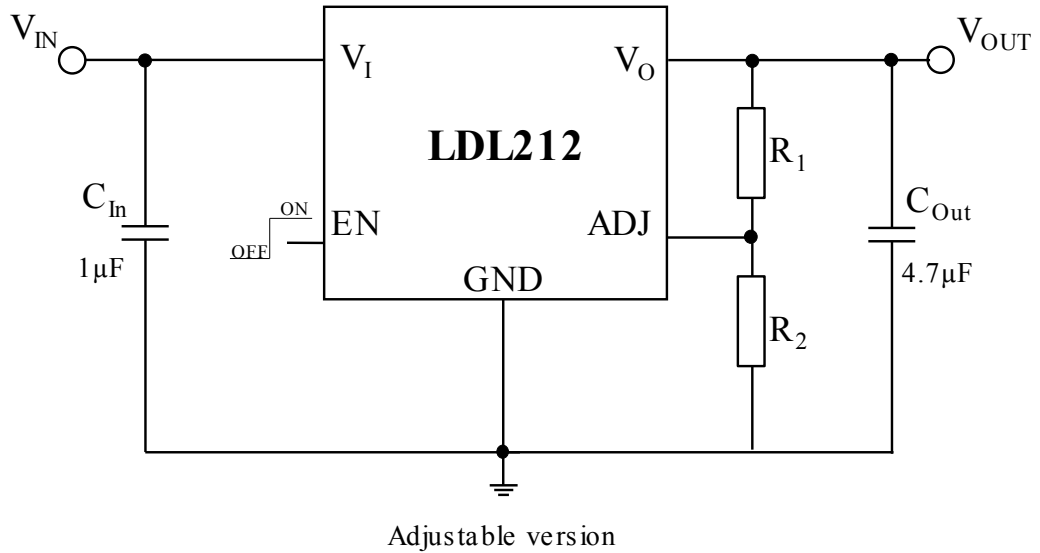
Table 1. Pin description

Pin name	Pin number (SO-8)	Pin number (DFN6)	Description
$V_{IN}$	4	4	Input voltage
$V_{OUT}$	1	3	Output voltage
GND	2, 3, 6, 7	1	Ground
ADJ/sense	8	2	Feedback pin for adjustable version / $V_{OUT}$ sense on fixed version
EN	5	6	Enable pin. The device is in off-state when this pin is pulled low
NC	-	5	Not connected
GND	-	exposed pad	Exposed pad must be connected to GND

1. The sense pin on the fixed version must be connected to  $V_{OUT}$  for proper operation.

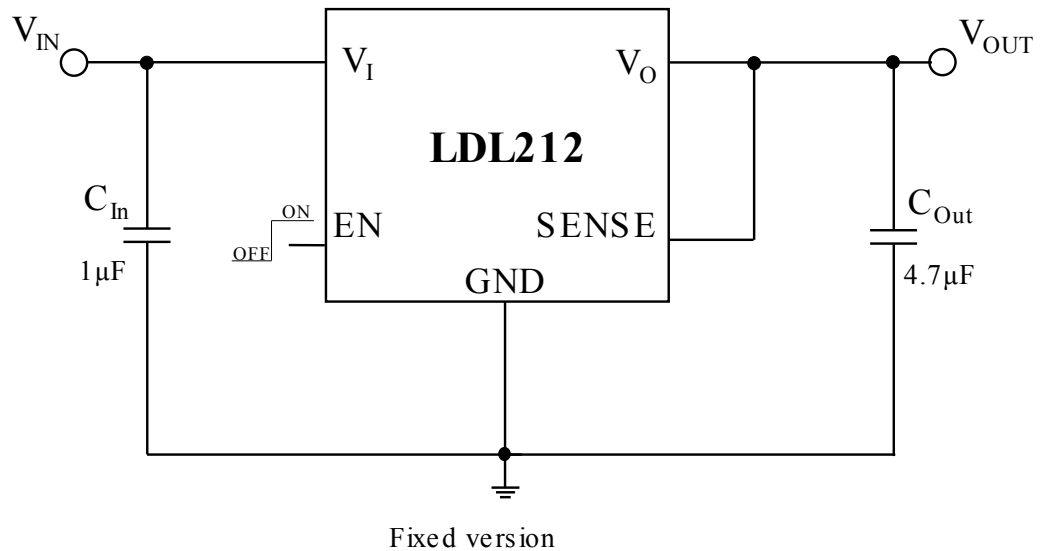
### 3 Typical application

Figure 4. Typical application circuit (adjustable version)



GIPD011220151346MT

Figure 5. Typical application circuit (fixed version)



GIPD011220151347MT

Note:  $R_1$  and  $R_2$  are calculated according to the following formula:  $R_1 = R_2 \times (V_{OUT}/V_{ADJ} - 1)$ . The output voltage of the adjustable version can be set from 1.18 V to  $V_{IN} - V_{DROPMAX}$ , where  $V_{DROPMAX}$  is the maximum dropout voltage, as defined in Table 4. Electrical characteristics.

## 4 Maximum ratings

**Table 2. Absolute maximum ratings**

Symbol	Parameter	Value	Unit
$V_{IN}$	DC input voltage	- 0.3 to 20	V
$V_{OUT}$	DC output voltage	- 0.3 to $V_{IN} + 0.3$	V
$V_{EN}$	Enable input voltage	- 0.3 to $V_{IN} + 0.3$	V
$V_{SENSE}$	Output sense pin voltage	- 0.3 to $V_{IN} + 0.3$	V
$V_{ADJ}$	ADJ pin voltage	- 0.3 to 2	V
$I_{OUT}$	Output current	Internally limited	mA
$P_D$	Power dissipation	Internally limited	mW
$T_{STG}$	Storage temperature range	- 55 to 150	°C
$T_{OP}$	Operating junction temperature range	- 40 to 125	°C

*Note: Absolute maximum ratings are those values beyond which damage to the device may occur. Functional operation under these conditions is not implied.*

**Table 3. Thermal data**

Symbol	Parameter	Value	Unit
SO-8 batwing plastic micropackage	Thermal resistance junction-to-case	20	°C/W
	Thermal resistance junction-to-ambient	55	
DFN6 (2x2)	Thermal resistance junction-to-case	15	
	Thermal resistance junction-to-ambient	65	
DFN6 (3x3)	Thermal resistance junction-to-case	10	
	Thermal resistance junction-to-ambient	55	

## 5 Electrical characteristics

$T_J = 25\text{ }^\circ\text{C}$ ,  $V_{IN} = V_{OUT(NOM)} + 1\text{ V}$ ,  $C_{IN} = 1\text{ }\mu\text{F}$ ,  $C_{OUT} = 4.7\text{ }\mu\text{F}$ ,  $I_{OUT} = 10\text{ mA}$ ,  $V_{EN} = V_{IN}$ , unless otherwise specified. ( For  $V_{OUT(NOM)} \leq 1.5\text{ V}$ ,  $V_{IN} = 2.7\text{ V}$ .)

**Table 4. Electrical characteristics**

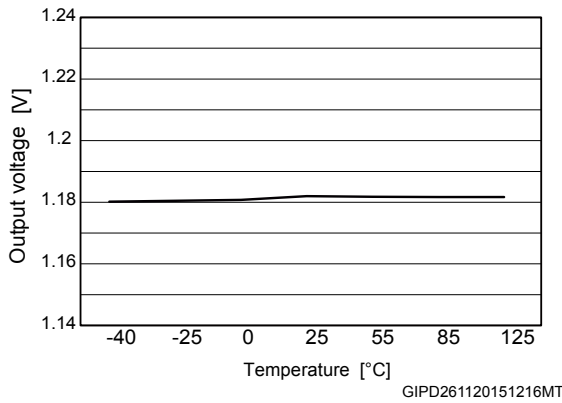
Symbol	Parameter	Test conditions	Min.	Typ.	Max.	Unit
$V_{IN}$	Operating input voltage		2.5		18	V
$V_{UVLO}$	Turn-on threshold			2.3	2.4	V
	Hysteresis			200		mV
$V_{OUT}$	$V_{OUT}$ accuracy	$I_{OUT} = 10\text{ mA}$	-2		2	%
		$T_J = 25\text{ }^\circ\text{C}$				
		$I_{OUT} = 10\text{ mA}$	-3		3	%
		$-40\text{ }^\circ\text{C} < T_J < 125\text{ }^\circ\text{C}$				
$V_{ADJ}$	Adjustable pin voltage	$V_{IN} = 2.5\text{ V}$ , $I_{OUT} = 10\text{ mA}$		1.18		V
		$T_J = 25\text{ }^\circ\text{C}$	-2		+2	%
		$V_{IN} = 2.5\text{ V}$ , $I_{OUT} = 10\text{ mA}$	-3		+3	%
		$-40\text{ }^\circ\text{C} < T_J < 125\text{ }^\circ\text{C}$				
$I_{ADJ}$	Adjustable pin current	$V_{IN} = 2.5\text{ V}$ , $I_{OUT} = 10\text{ mA}$		20		nA
$\Delta V_{OUT}$	Line regulation	$V_{OUT} + 1\text{ V} \leq V_{IN} \leq 18\text{ V}$ , $I_{OUT} = 10\text{ mA}$		0.002	0.01	%/V
$\Delta V_{OUT}$	Load regulation	$I_{OUT} = 10\text{ mA}$ to 1.2 A		0.0001	0.0005	%/mA
$V_{DROPO}$	Dropout voltage <sup>(1)</sup>	$I_{OUT} = 1.2\text{ A}$ , $V_{OUT} > 3\text{ V}$		350	600	mV
	Dropout voltage for SO-8 <sup>(1)</sup>	$-40\text{ }^\circ\text{C} < T_J < 125\text{ }^\circ\text{C}$			700	
eN	Output noise voltage	10 Hz to 100 kHz, $I_{OUT} = 100\text{ mA}$		60		$\mu\text{V}_{RMS}/V_{OUT}$
SVR	Supply voltage rejection	$V_{IN} = V_{OUT(NOM)} + 1\text{ V} \pm V_{RIPPLE}$		87		dB
		$V_{RIPPLE} = 0.5\text{ V}$ , $f = 120\text{ Hz}$				
		$V_{IN} = V_{OUT(NOM)} + 1\text{ V} \pm V_{RIPPLE}$		75		
		$V_{RIPPLE} = 0.5\text{ V}$ , $f = 1\text{ kHz}$				
		$V_{IN} = V_{OUT(NOM)} + 1\text{ V} \pm V_{RIPPLE}$		50		
$V_{RIPPLE} = 0.5\text{ V}$ , $f = 100\text{ kHz}$						
$I_Q$	Quiescent current	$I_{OUT} = 0\text{ mA}$ to 1.2 A		250	380	$\mu\text{A}$
		$-40\text{ }^\circ\text{C} < T_J < 125\text{ }^\circ\text{C}$				
		$V_{IN}$ input current in OFF mode		0.3	1.5	
		$V_{EN} = \text{GND}$ , $V_{IN} = 18\text{ V}$				
$I_{SC}$	Short-circuit current	$R_L = 0$	1.5	2		A
$V_{EN}$	Enable input logic low	$V_{IN} = 2.5\text{ V}$ to 18 V			0.4	V
	Enable input logic high	$-40\text{ }^\circ\text{C} < T_J < 85\text{ }^\circ\text{C}$				
		$V_{IN} = 2.5\text{ V}$ to 18 V	1.2			

Symbol	Parameter	Test conditions	Min.	Typ.	Max.	Unit
$V_{EN}$		$-40\text{ }^{\circ}\text{C} < T_J < 85\text{ }^{\circ}\text{C}$				V
$I_{EN}$	Enable input current			1.5		$\mu\text{A}$
		$V_{EN} = V_{IN}, V_{IN} = 18\text{ V}$		16	20	
$T_{ON}$	Turn-on time <sup>(2)</sup>			120		$\mu\text{s}$
$T_{SHDN}$	Thermal shutdown			175		$^{\circ}\text{C}$
	Hysteresis			25		

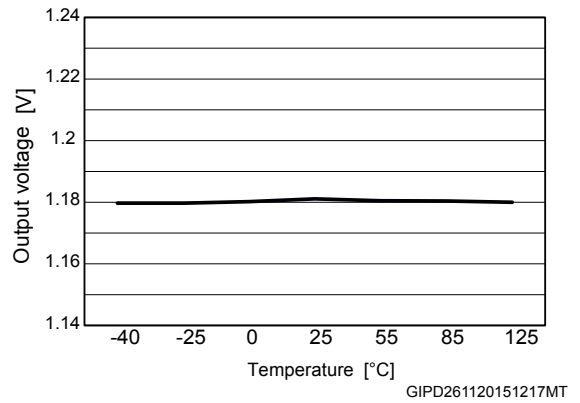
1. Dropout voltage is the input-to-output voltage difference at which the output voltage is 100 mV below its nominal value. This specification is not valid for output voltages below 2.2 V.
2. Turn-on time is the time measured between the enable input just exceeding  $V_{EN}$  high value and the output voltage just reaching 95% of its nominal value.

## 6 Typical performance characteristics

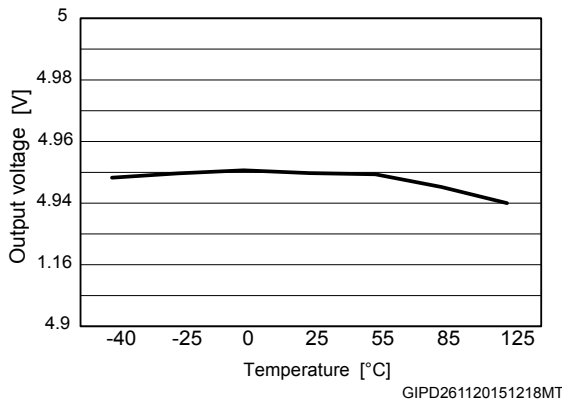
**Figure 6. Output voltage vs. temperature**  
 ( $V_{IN} = 2.5\text{ V}$ ,  $V_{OUT} = V_{ADJ}$ ,  $I_{OUT} = 0\text{ mA}$ )



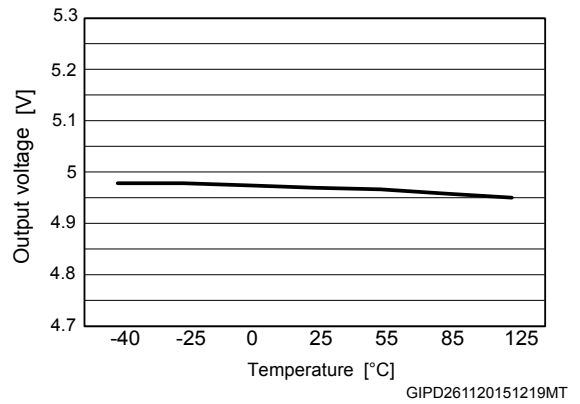
**Figure 7. Output voltage vs. temperature**  
 ( $V_{IN} = 2.5\text{ V}$ ,  $V_{OUT} = V_{ADJ}$ ,  $I_{OUT} = 1200\text{ mA}$ )



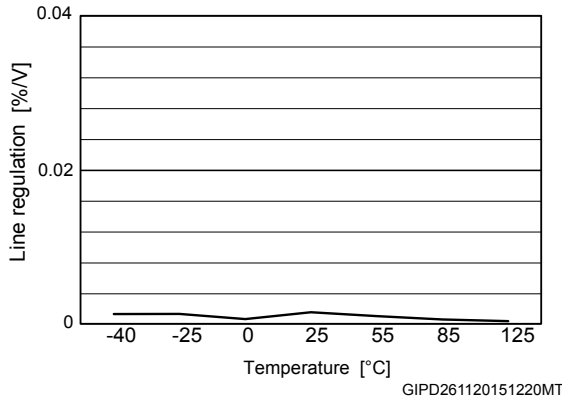
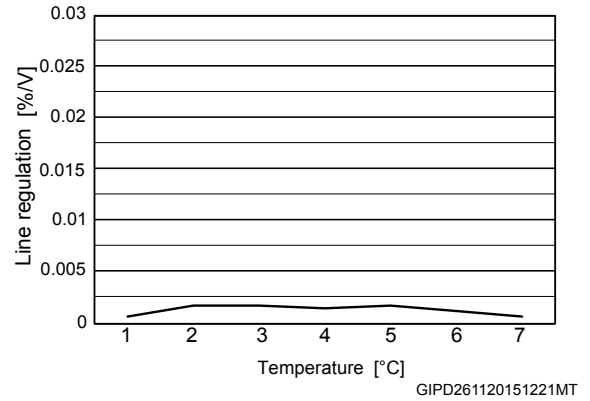
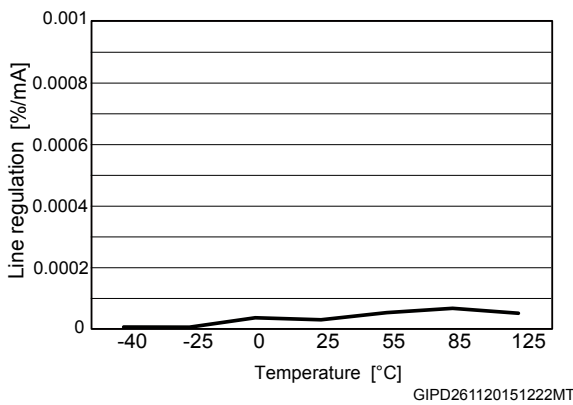
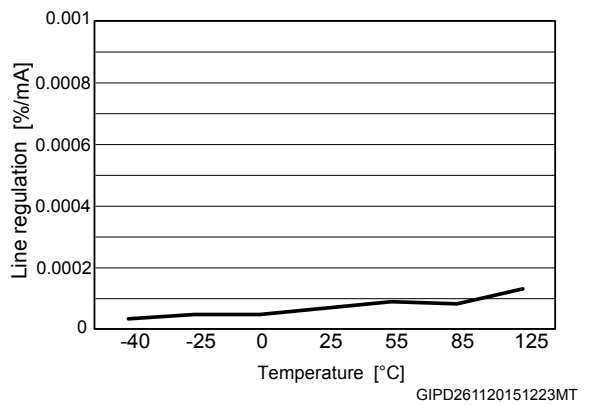
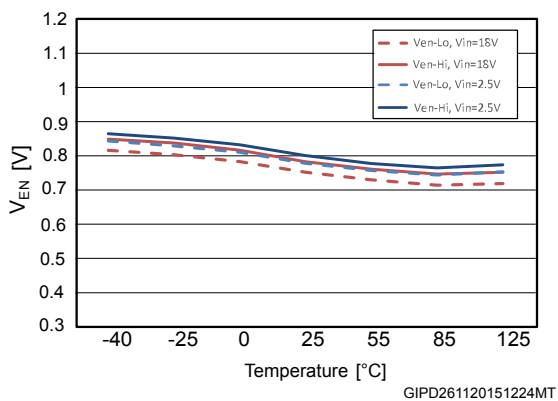
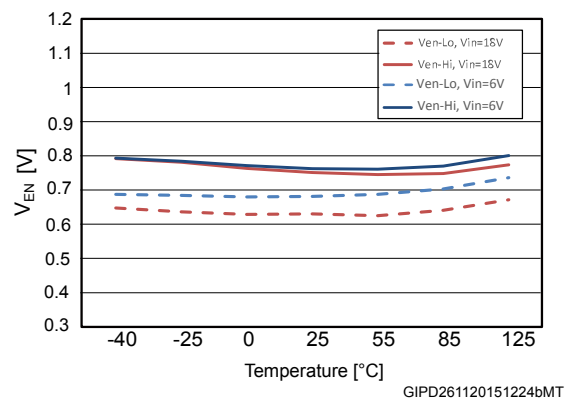
**Figure 8. Output voltage vs. temperature** ( $V_{IN} = 6\text{ V}$ ,  
 $V_{OUT} = 5\text{ V}$ ,  $I_{OUT} = 10\text{ mA}$ )

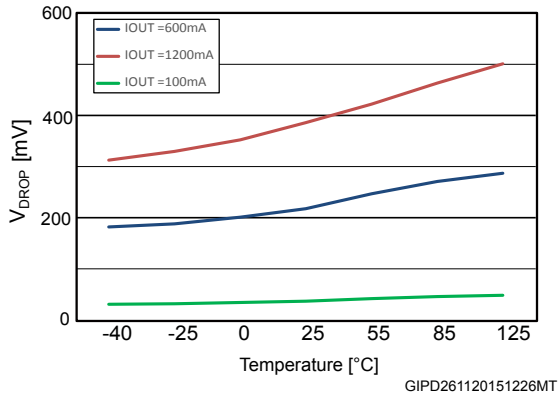
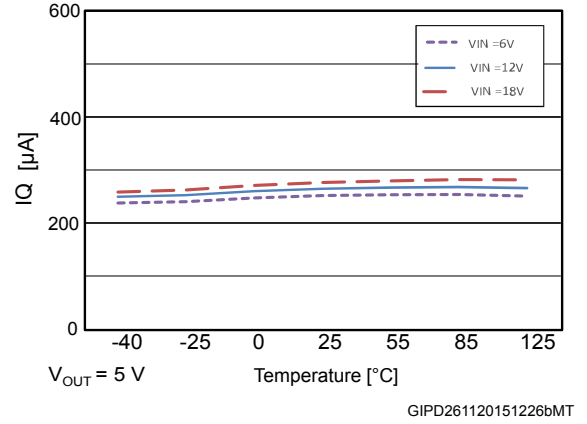
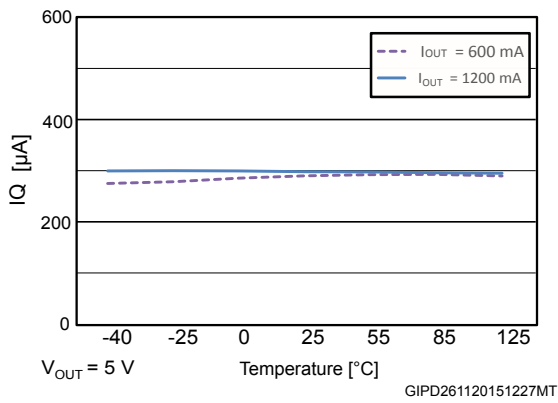
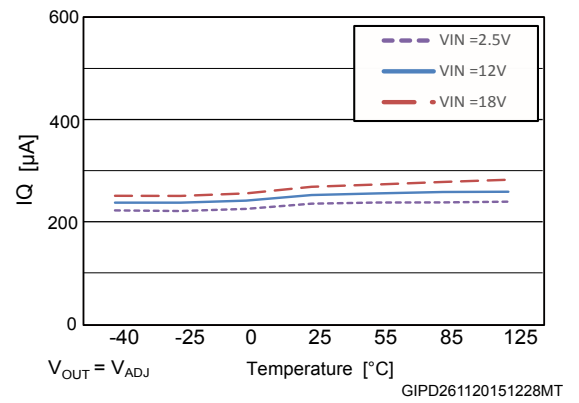
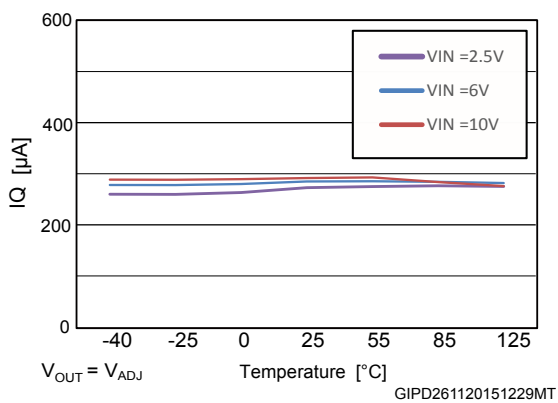
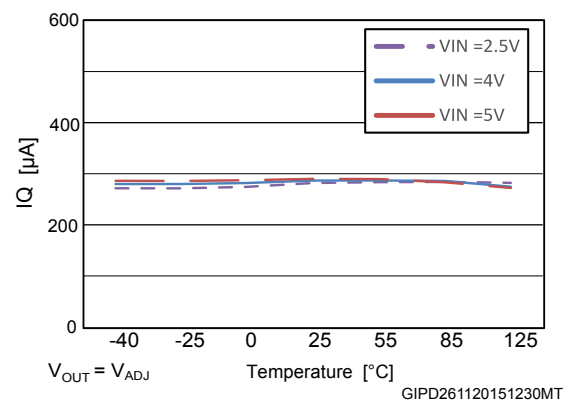


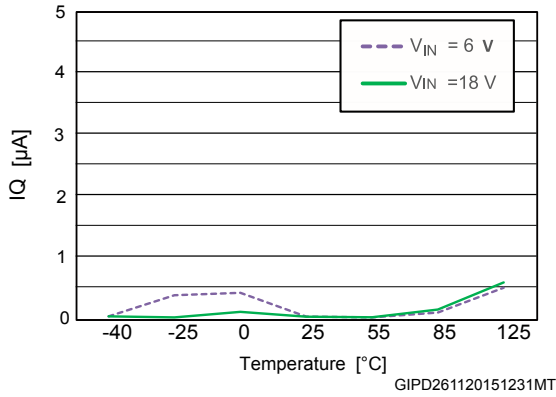
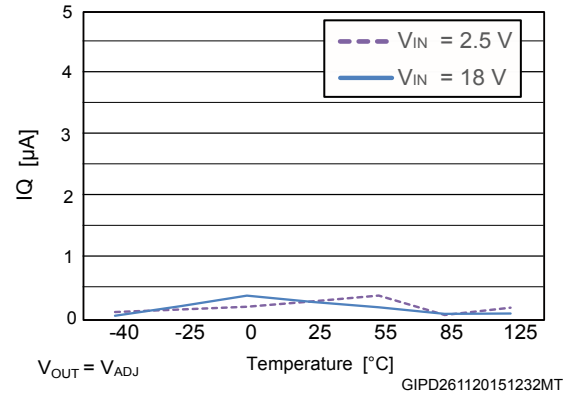
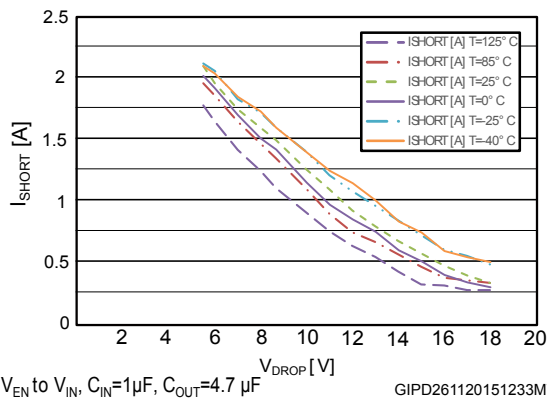
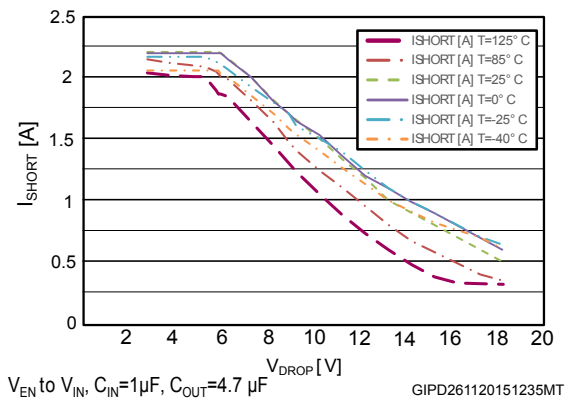
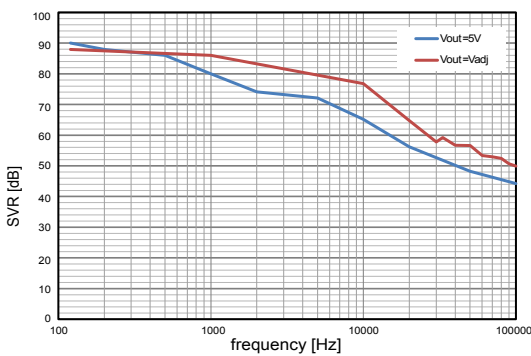
**Figure 9. Output voltage vs. temperature** ( $V_{IN} = 6\text{ V}$ ,  
 $V_{OUT} = 5\text{ V}$ ,  $I_{OUT} = 1200\text{ mA}$ )





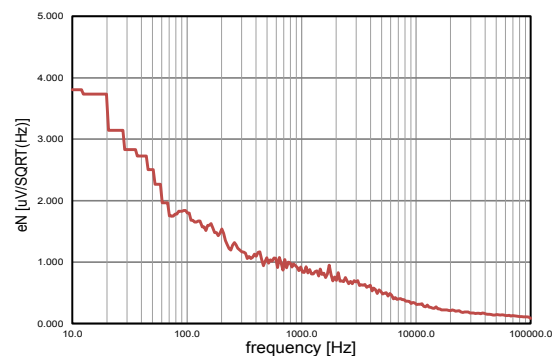
**Figure 10. Line regulation vs. temperature ( $V_{IN} = 6$  to 18 V,  $V_{OUT} = 5$  V,  $I_{OUT} = 10$  mA)**

**Figure 11. Line regulation vs. temperature ( $V_{IN} = 2.5$  to 18 V,  $V_{OUT} = V_{ADJ}$ ,  $I_{OUT} = 10$  mA)**

**Figure 12. Load regulation vs. temperature ( $V_{IN} = 6$  V,  $V_{OUT} = 5$  V,  $I_{OUT} = 10$  to 1200 mA)**

**Figure 13. Load regulation vs. temperature ( $V_{IN} = 2.5$  V,  $V_{OUT} = V_{ADJ}$ ,  $I_{OUT} = 0$  to 1200 mA)**

**Figure 14. Enable thresholds vs. temperature ( $V_{OUT} = V_{ADJ}$ )**

**Figure 15. Enable thresholds vs. temperature ( $V_{OUT} = 5$  V)**


**Figure 16. Dropout voltage vs. temperature**

**Figure 17. Quiescent current vs. temperature ( $V_{OUT} = 5\text{ V}$ ,  $I_{OUT} = 0\text{ mA}$ )**

**Figure 18. Quiescent current vs. temperature ( $V_{OUT} = 5\text{ V}$ ,  $I_{OUT} = 600\text{ mA}$ ,  $1.2\text{ A}$ )**

**Figure 19. Quiescent current vs. temperature ( $V_{OUT} = V_{ADJ}$ ,  $I_{OUT} = 0\text{ mA}$ )**

**Figure 20. Quiescent current vs. temperature ( $V_{OUT} = V_{ADJ}$ ,  $I_{OUT} = 600\text{ mA}$ )**

**Figure 21. Quiescent current vs. temperature ( $V_{OUT} = V_{ADJ}$ ,  $I_{OUT} = 1.2\text{ A}$ )**


**Figure 22. Off-state current vs. temperature**  
 ( $V_{OUT} = 5\text{ V}$ )

**Figure 23. Off-state current vs. temperature**  
 ( $V_{OUT} = V_{ADJ}$ )

**Figure 24. Short-circuit current vs. dropout voltage**  
 ( $V_{OUT} = 5\text{ V}$ )

**Figure 25. Short-circuit current vs. dropout voltage**  
 ( $V_{OUT} = V_{ADJ}$ )

**Figure 26. SVR vs. frequency**


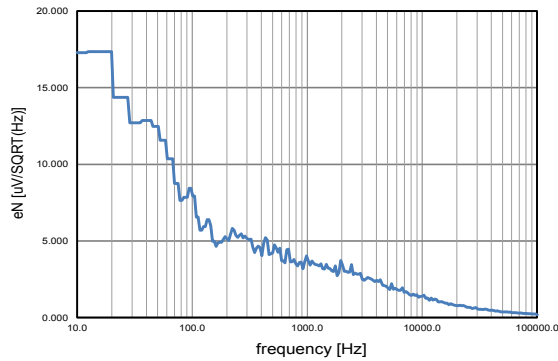
For  $V_{OUT} = 5\text{ V}$ ,  $V_{IN} = V_{EN}$  from 5.5 to 6.5V,  $I_{OUT} = 10\text{ mA}$ ,  $C_{IN} = 1\mu\text{F}$ ,  $C_{OUT} = 4.7\mu\text{F}$   
 For  $V_{OUT} = V_{ADJ}$ ,  $V_{IN} = V_{EN}$  from 2.5 to 3.5V,  $I_{OUT} = 10\text{ mA}$ , No  $C_{IN}$ ,  $C_{OUT} = 4.7\mu\text{F}$

GIPD261120151236MT

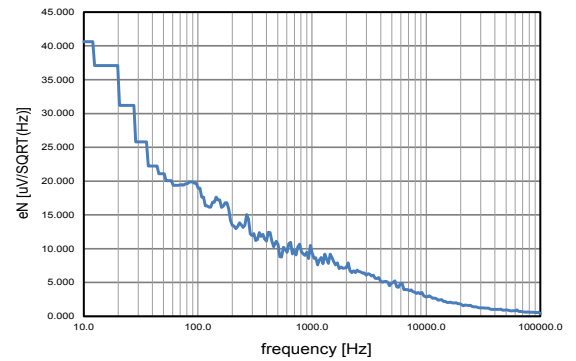
**Figure 27. Output noise spectral density**  
 ( $V_O = V_{ADJ}$ )


$V_{IN} = V_{EN} = 2.5\text{ V}$ ,  $V_{OUT} = V_{ADJ}$ ,  $I_{OUT} = 100\text{ mA}$ ,  $C_{IN} = 1\mu\text{F}$ ,  $C_{OUT} = 4.7\mu\text{F}$

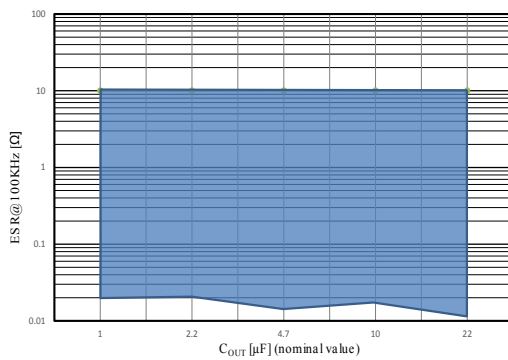
GIPD261120151237MT

**Figure 28. Output noise spectral density ( $V_O = 5\text{ V}$ )**


$V_{IN} = V_{EN} = 6\text{ V}$ ,  $V_{OUT} = 5\text{ V}$ ,  $I_{OUT} = 100\text{ mA}$ ,  $C_{IN} = 1\text{ }\mu\text{F}$ ,  $C_{OUT} = 4.7\text{ }\mu\text{F}$   
GIPD261120151238MT

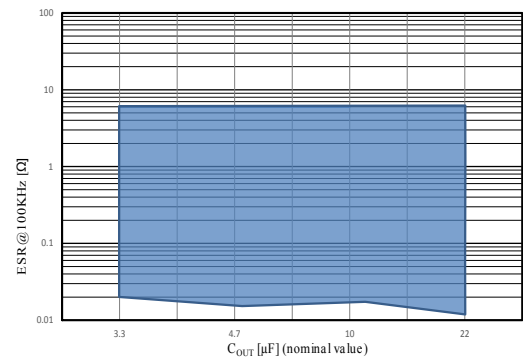
**Figure 29. Output noise spectral density ( $V_O = 12\text{ V}$ )**


$V_{IN} = V_{EN} = 6\text{ V}$ ,  $V_{OUT} = 5\text{ V}$ ,  $I_{OUT} = 100\text{ mA}$ ,  $C_{IN} = 1\text{ }\mu\text{F}$ ,  $C_{OUT} = 4.7\text{ }\mu\text{F}$   
GIPD261120151239MT

**Figure 30. Stability plan ( $V_{OUT} = 5\text{ V}$ )**


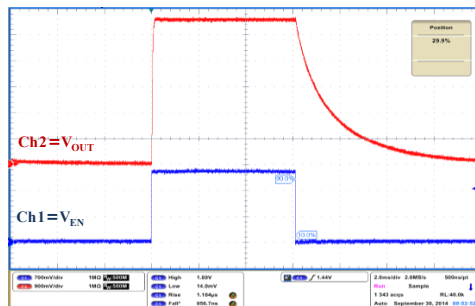
$V_{EN} = V_{IN} =$  from 6 V to 18 V,  $I_{OUT} =$  from 10 mA to 1.2 A  
(according to Max  $I_{OUT}$  vs  $V_{drop}$  characteristics),  $C_{IN} = 1\text{ }\mu\text{F}$

GIPD301120151004MT

**Figure 31. Stability plan ( $V_{OUT} = V_{ADJ}$ )**


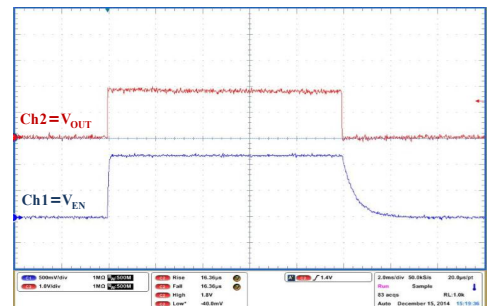
$V_{EN} = V_{IN} =$  from 2.5 V to 18 V,  $I_{OUT} =$  from 10 mA to 1.2 A  
(according to Max  $I_{OUT}$  vs  $V_{drop}$  characteristics),  $C_{IN} = 1\text{ }\mu\text{F}$

GIPD301120151005MT

**Figure 32. Startup with enable ( $V_{OUT} = 5\text{ V}$ )**


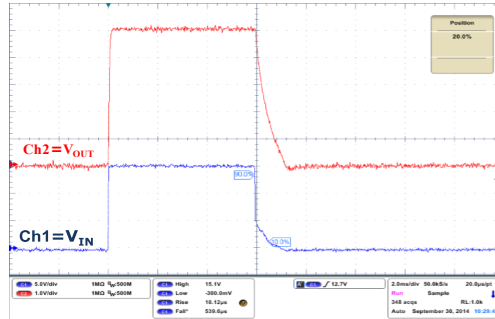
$V_{IN} = 15\text{ V}$ ,  $V_{EN}$  from 0 to 2 V,  $I_{OUT} = 10\text{ mA}$ ,  $C_{IN} = C_{OUT} = 1\text{ }\mu\text{F}$ ,  $T_{rise} = 1\text{ }\mu\text{s}$

GIPD301120151405MT

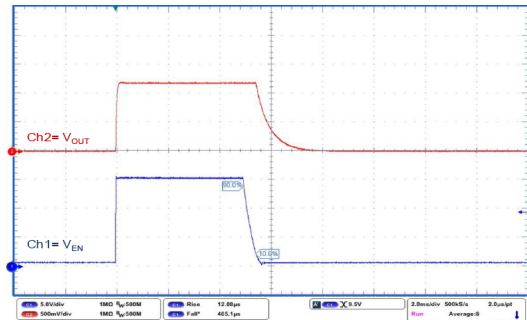
**Figure 33. Startup with enable ( $V_{OUT} = V_{ADJ}$ )**


$V_{IN} = 15\text{ V}$ ,  $V_{EN}$  from 0 to 2 V,  $I_{OUT} = 10\text{ mA}$ ,  $C_{IN} = C_{OUT} = 1\text{ }\mu\text{F}$ ,  $T_{rise} = 1\text{ }\mu\text{s}$

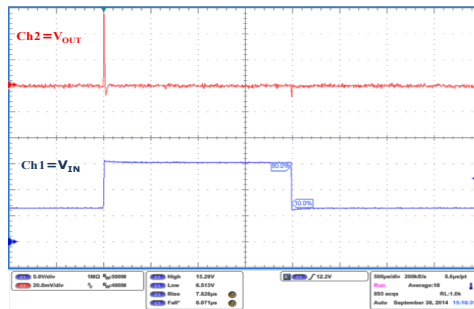
GIPD301120151406MT

**Figure 34. Turn-on time ( $V_{OUT} = 5\text{ V}$ )**

 $V_{EN} = V_{IN} =$  from 0 to 15 V,  $I_{OUT} = 10\text{ mA}$ ,  $C_{OUT} = 1\text{ }\mu\text{F}$ ,  $T_{rise} = 10\text{ }\mu\text{s}$ 

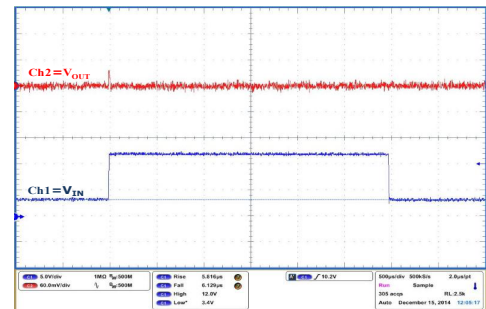
GIPD301120151407MT

**Figure 35. Turn-on time ( $V_{OUT} = V_{ADJ}$ )**

 $V_{EN} = V_{IN} =$  from 0 to 15 V,  $I_{OUT} = 10\text{ mA}$ ,  $C_{IN} = 1\text{ }\mu\text{F}$ ,  $C_{OUT} = 4.7\text{ }\mu\text{F}$ ,  $t_{rise} = 10\text{ }\mu\text{s}$ 

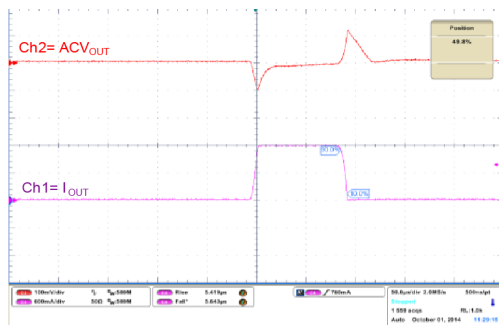
GIPD301120151408MT

**Figure 36. Line transient ( $V_{OUT} = 5\text{ V}$ )**

 $V_{IN} =$  from 6 to 15 V,  $I_{OUT} = 10\text{ mA}$ ,  $C_{OUT} = 4.7\text{ }\mu\text{F}$ ,  $t_r = 5\text{ }\mu\text{s}$ 

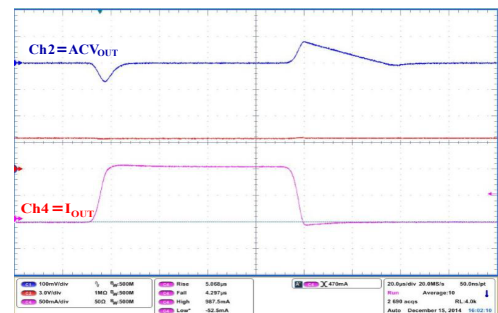
GIPD301120151409MT

**Figure 37. Line transient ( $V_{OUT} = V_{ADJ}$ )**

 $V_{IN} =$  from 3.5 to 15 V,  $I_{OUT} = 10\text{ mA}$ , NO  $C_{IN}$ ,  $C_{OUT} = 4.7\text{ }\mu\text{F}$ ,  $t_r = 5\text{ }\mu\text{s}$ 

GIPD301120151410MT

**Figure 38. Load transient ( $V_{OUT} = 5\text{ V}$ )**

 $V_{EN}$  to  $V_{CC}$ ,  $V_{IN} = 6\text{ V}$ ,  $I_{OUT} =$  from 10 mA to 1.2 A,  $C_{IN} = 1\text{ }\mu\text{F}$ ,  $C_{OUT} = 4.7\text{ }\mu\text{F}$ ,  $T_{rise} = 5\text{ }\mu\text{s}$ 

GIPD301120151411MT

**Figure 39. Load transient ( $V_{OUT} = V_{ADJ}$ )**

 $V_{EN}$  to  $V_{CC}$ ,  $V_{IN} = 3.5\text{ V}$ ,  $I_{OUT} =$  from 10 mA to 1.2 A,  $C_{IN} = 1\text{ }\mu\text{F}$ ,  $C_{OUT} = 4.7\text{ }\mu\text{F}$ ,  $T_{rise} = 5\text{ }\mu\text{s}$ 

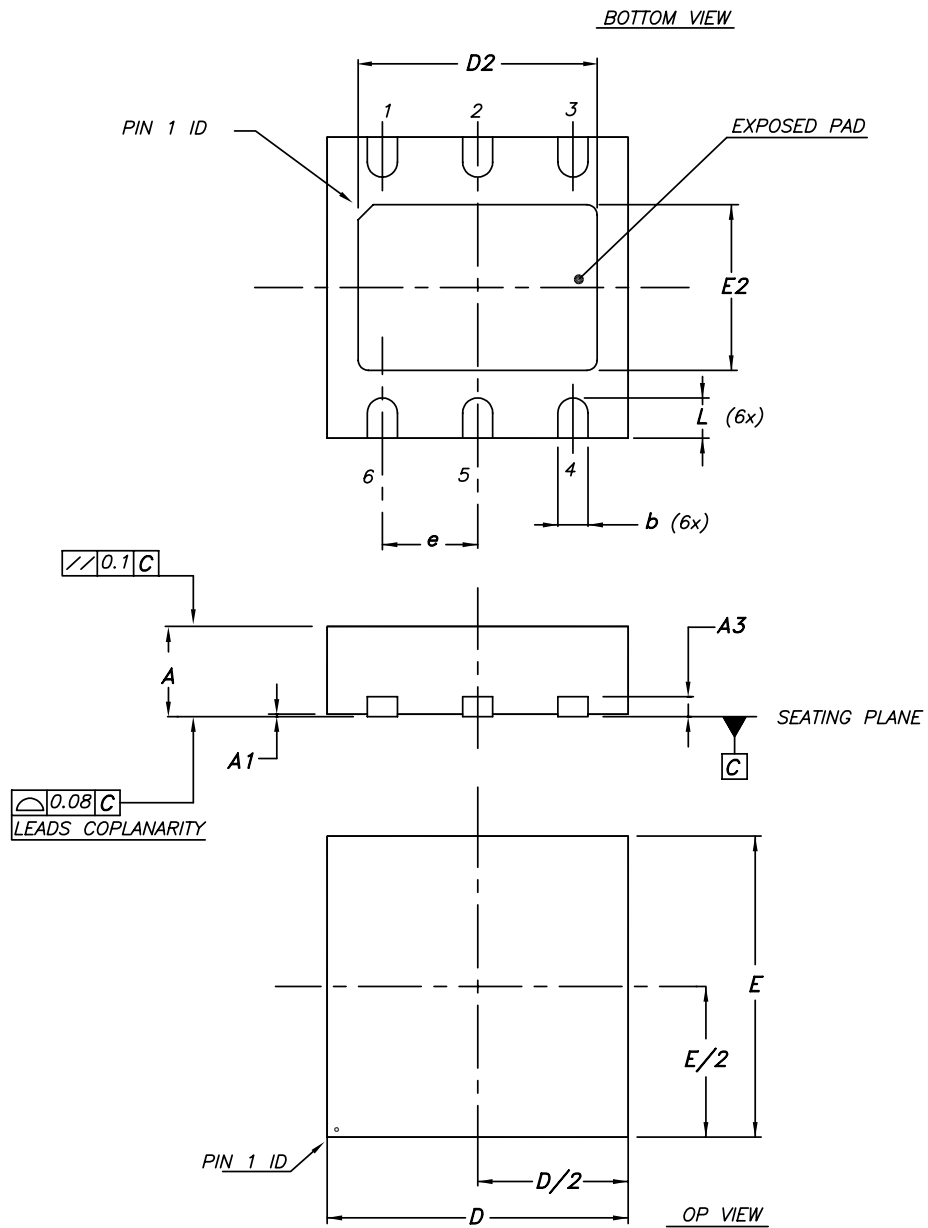
GIPD301120151412MT

## 7 Package information

In order to meet environmental requirements, ST offers these devices in different grades of **ECOPACK** packages, depending on their level of environmental compliance. ECOPACK specifications, grade definitions and product status are available at: [www.st.com](http://www.st.com). ECOPACK is an ST trademark.

### 7.1 DFN6 (3x3) package information

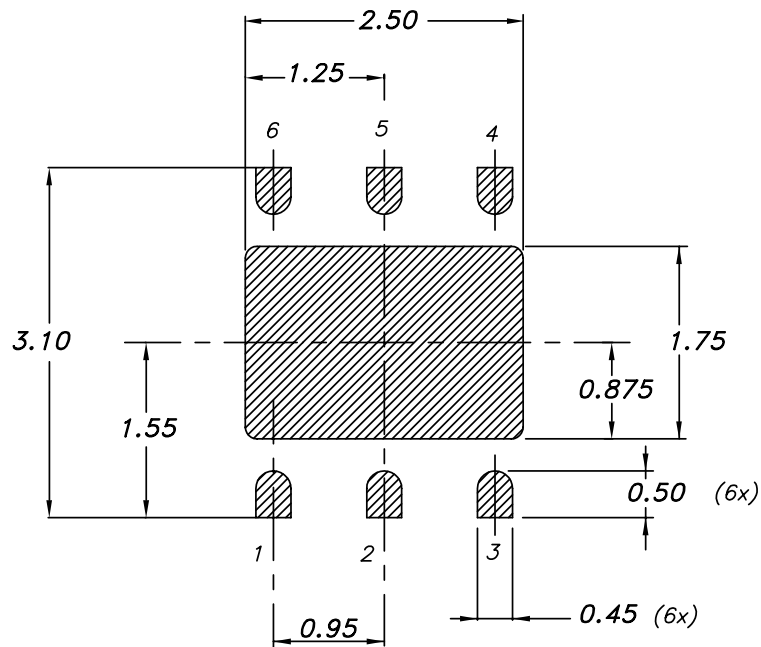
Figure 40. DFN6 (3x3) package outline



7946637\_C

**Table 5. DFN6 (3x3) mechanical data**

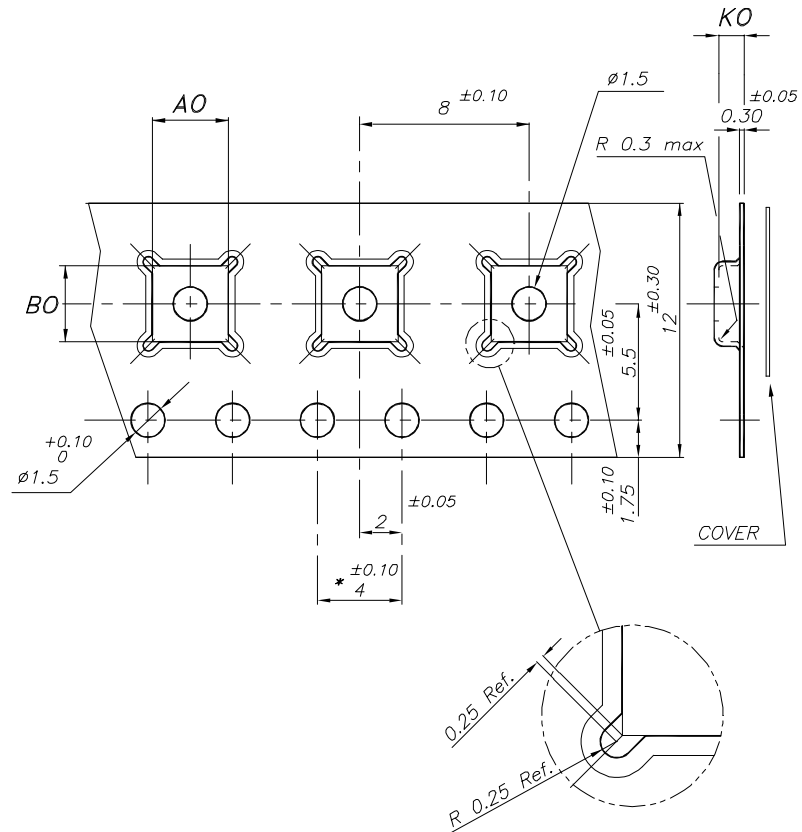
Dim.	mm		
	Min.	Typ.	Max.
A	0.80		1
A1	0	0.02	0.05
A3		0.20	
b	0.23		0.45
D	2.90	3	3.10
D2	2.23		2.50
E	2.90	3	3.10
E2	1.50		1.75
e		0.95	
L	0.30	0.40	0.50

**Figure 41. DFN6 (3x3) recommended footprint**
**FOOTPRINT RECOMMENDED**


7946637\_C

## 7.2 DFN6 (3x3) packing information

Figure 42. DFN6 (3x3) tape outline

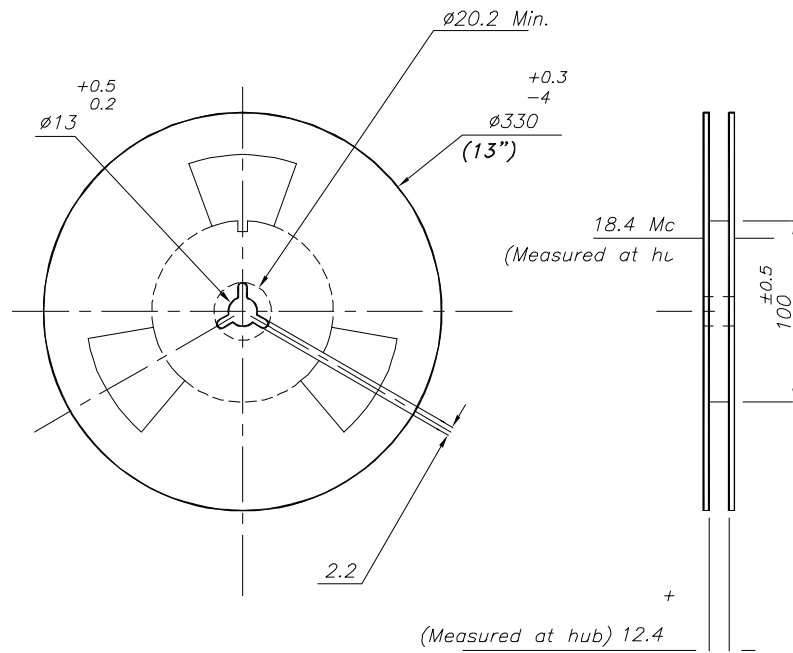


\* - 10 SPROCKET HOLE PITCH CUMULATIVE TOLERANCE  $\pm 0.20$

7875978\_N



Figure 43. DFN6 (3x3) reel outline



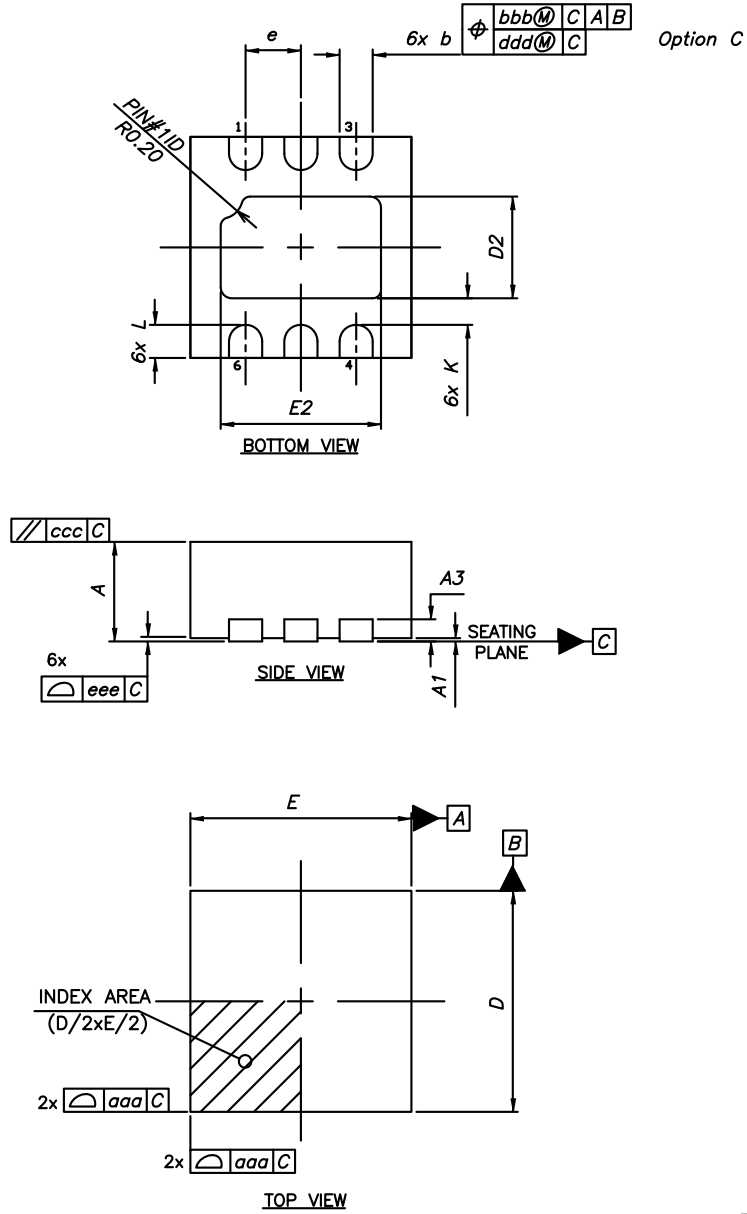
7875978\_N

Table 6. DFN6 (3x3) tape and reel mechanical data

Dim.	mm		
	Min.	Typ.	Max.
A0	3.20	3.30	3.40
B0	3.20	3.30	3.40
K0	1	1.10	1.20

7.3 DFN6 (2x2) package information

Figure 44. DFN6 (2x2) package outline

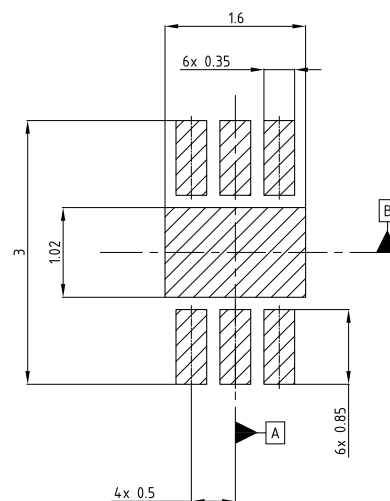


7733060

Table 7. DFN6 (2x2) mechanical data

Dim.	mm		
	Min.	Typ.	Max.
A	0.70	0.75	0.80
A1	0.00	0.02	0.05
A3	-	0.203 ref	-
b	0.25	0.30	0.35
D	-	2.00	-
E	-	2.00	-
e	-	0.50	-
D2	0.77	0.92	1.02
E2	1.30	1.45	1.55
K	0.15	-	-
L	0.20	0.30	0.40
aaa	-	0.05	-
bbb	-	0.10	-
ccc	-	0.10	-
ddd	-	0.05	-
eee	-	0.08	-

Figure 45. DFN6 (2x2) recommended footprint



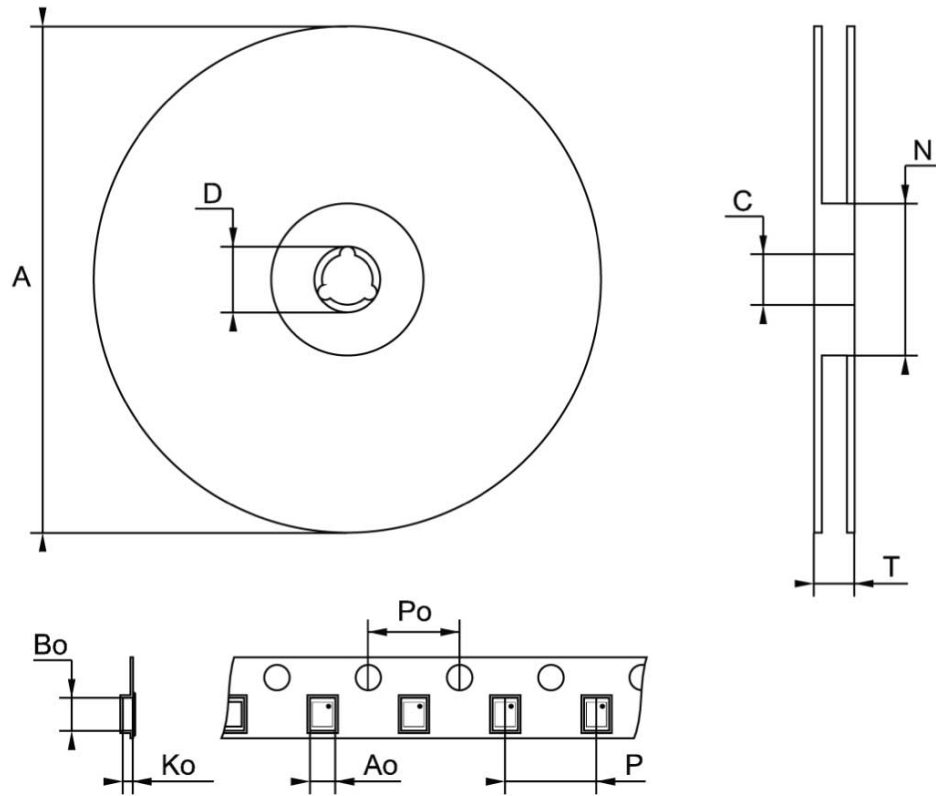
Notes:

- 1) This footprint is able to ensure insulation up to 32 Vrms (according to CEI IEC 664-1)
- 2) The device must be positioned within  $\oplus 0.02$  A B

7733060 revE

## 7.4 DFN6 (2x2) packing information

Figure 46. DFN6 (2 x 2 mm) reel outline



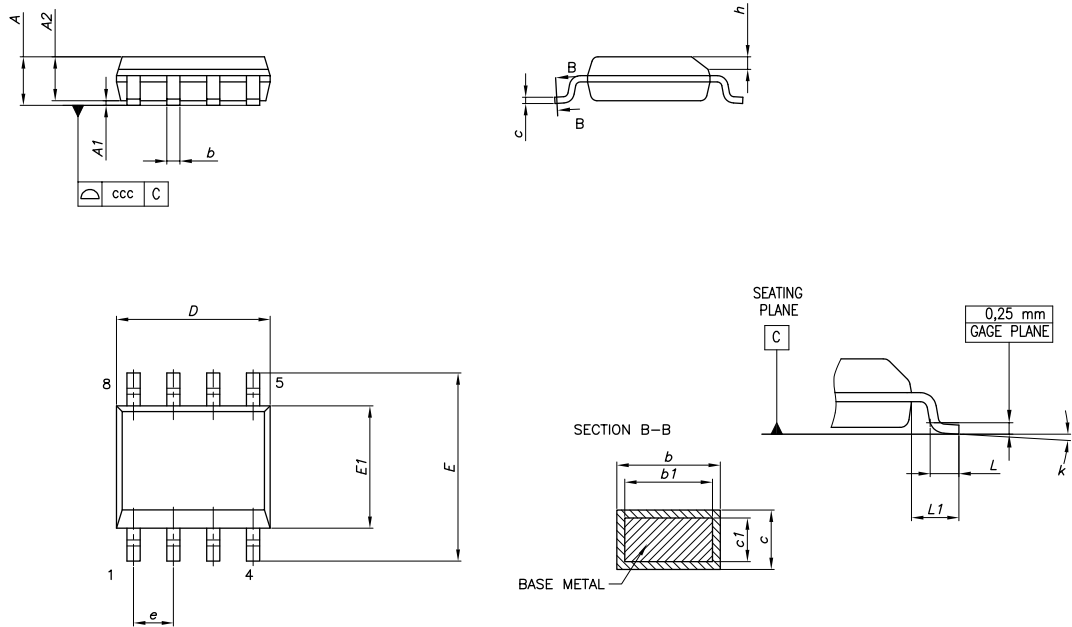
Note: Drawing not in scale

Table 8. DFN6 (2 x 2 mm) tape and reel mechanical data

Dim.	mm		
	Min.	Typ.	Max.
A			180
C	12.8		13.2
D	20.2		
N	60		
T			14.4
A0		2.4	
B0		2.4	
K0		1.3	
P0		4	
P		4	

## 7.5 SO8 package information

Figure 47. SO-8 batwing package outline

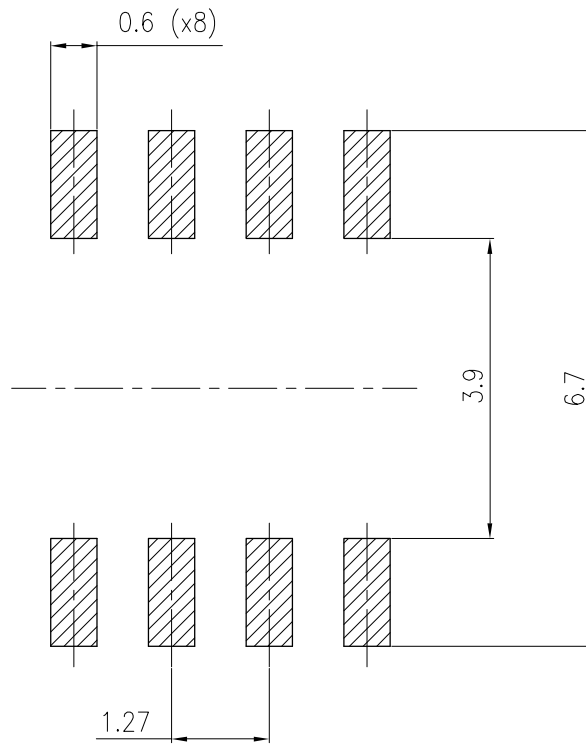


0016023\_G

Table 9. SO-8 batwing mechanical data

Dim.	mm		
	Min.	Typ.	Max.
A			1.75
A1	0.10		0.25
A2	1.25		
b	0.31		0.51
b1	0.28		0.48
c	0.10		0.25
c1	0.10		0.23
D	4.80	4.90	5.00
E	5.80	6.00	6.20
E1	3.80	3.90	4.00
e		1.27	
h	0.25		0.50
L	0.40		1.27
L1		1.04	
L2		0.25	
k	0°		8°
ccc			0.10

Figure 48. SO-8 batwing recommended footprint



0016023\_GU

## 8 Ordering information

**Table 10. Order code**

DFN6 (3x3)	DFN6 (2x2)	SO-8 batwing plastic micropackage	Output voltage (V)
LDL212PU12R <sup>(1)</sup>			1.2
LDL212PU15R			1.5
LDL212PU18R <sup>(1)</sup>			1.8
LDL212PU25R <sup>(1)</sup>			2.5
LDL212PU30R <sup>(1)</sup>			3
	LDL212PV33R	LDL212D33R	3.3
LDL212PU50R			5
LDL212PUR	LDL212PVR	LDL212DR	Adjustable

1. Available on request.

## Revision history

**Table 11. Document revision history**

Date	Revision	Changes
02-Mar-2016	1	Initial release.
19-Sep-2016	2	Updated Table 3: "Thermal data" and Section 5: "Electrical characteristics". Minor text changes.
17-Sep-2018	3	Added: GND pin name in Table 1. Pin description and new order code LDL212D33R in Table 10. Order code.
16-Apr-2019	4	In Table 10. Order code, in LDL2012D33R the note has been removed. Updated GND description in Table 1. Pin description.
21-Feb-2020	5	Added dropout voltage for SO-8 in <a href="#">Table 4. Electrical characteristics</a> .



## Contents

<b>1</b>	<b>Block diagram</b> .....	<b>2</b>
<b>2</b>	<b>Pin configuration</b> .....	<b>3</b>
<b>3</b>	<b>Typical application</b> .....	<b>4</b>
<b>4</b>	<b>Maximum ratings</b> .....	<b>5</b>
<b>5</b>	<b>Electrical characteristics</b> .....	<b>6</b>
<b>6</b>	<b>Typical performance characteristics</b> .....	<b>8</b>
<b>7</b>	<b>Package information</b> .....	<b>14</b>
7.1	DFN6 (3x3) package information .....	14
7.2	DFN6 (3x3) packing information .....	16
7.3	DFN6 (2x2) package information .....	18
7.4	DFN6 (2x2) packing information .....	20
7.5	SO8-batwing package information .....	21
7.6	SO8-batwing packing information .....	0
<b>8</b>	<b>Ordering information</b> .....	<b>23</b>
	<b>Revision history</b> .....	<b>24</b>
	<b>Contents</b> .....	<b>25</b>
	<b>List of tables</b> .....	<b>26</b>
	<b>List of figures</b> .....	<b>27</b>

## List of tables

<b>Table 1.</b>	Pin description . . . . .	3
<b>Table 2.</b>	Absolute maximum ratings . . . . .	5
<b>Table 3.</b>	Thermal data . . . . .	5
<b>Table 4.</b>	Electrical characteristics . . . . .	6
<b>Table 5.</b>	DFN6 (3x3) mechanical data . . . . .	15
<b>Table 6.</b>	DFN6 (3x3) tape and reel mechanical data . . . . .	17
<b>Table 7.</b>	DFN6 (2x2) mechanical data . . . . .	19
<b>Table 8.</b>	DFN6 (2 x 2 mm) tape and reel mechanical data . . . . .	20
<b>Table 9.</b>	SO-8 batwing mechanical data . . . . .	21
<b>Table 10.</b>	Order code . . . . .	23
<b>Table 11.</b>	Document revision history . . . . .	24

## List of figures

<b>Figure 1.</b>	Block diagram (fixed) . . . . .	2
<b>Figure 2.</b>	Block diagram (adjustable) . . . . .	2
<b>Figure 3.</b>	Pin configuration (top view) . . . . .	3
<b>Figure 4.</b>	Typical application circuit (adjustable version) . . . . .	4
<b>Figure 5.</b>	Typical application circuit (fixed version) . . . . .	4
<b>Figure 6.</b>	Output voltage vs. temperature ( $V_{IN} = 2.5\text{ V}$ , $V_{OUT} = V_{ADJ}$ , $I_{OUT} = 0\text{ mA}$ ) . . . . .	8
<b>Figure 7.</b>	Output voltage vs. temperature ( $V_{IN} = 2.5\text{ V}$ , $V_{OUT} = V_{ADJ}$ , $I_{OUT} = 1200\text{ mA}$ ) . . . . .	8
<b>Figure 8.</b>	Output voltage vs. temperature ( $V_{IN} = 6\text{ V}$ , $V_{OUT} = 5\text{ V}$ , $I_{OUT} = 10\text{ mA}$ ) . . . . .	8
<b>Figure 9.</b>	Output voltage vs. temperature ( $V_{IN} = 6\text{ V}$ , $V_{OUT} = 5\text{ V}$ , $I_{OUT} = 1200\text{ mA}$ ) . . . . .	8
<b>Figure 10.</b>	Line regulation vs. temperature ( $V_{IN} = 6\text{ to }18\text{ V}$ , $V_{OUT} = 5\text{ V}$ , $I_{OUT} = 10\text{ mA}$ ) . . . . .	9
<b>Figure 11.</b>	Line regulation vs. temperature ( $V_{IN} = 2.5\text{ to }18\text{ V}$ , $V_{OUT} = V_{ADJ}$ , $I_{OUT} = 10\text{ mA}$ ) . . . . .	9
<b>Figure 12.</b>	Load regulation vs. temperature ( $V_{IN} = 6\text{ V}$ , $V_{OUT} = 5\text{ V}$ , $I_{OUT} = 10\text{ to }1200\text{ mA}$ ) . . . . .	9
<b>Figure 13.</b>	Load regulation vs. temperature ( $V_{IN} = 2.5\text{ V}$ , $V_{OUT} = V_{ADJ}$ , $I_{OUT} = 0\text{ to }1200\text{ mA}$ ) . . . . .	9
<b>Figure 14.</b>	Enable thresholds vs. temperature ( $V_{OUT} = V_{ADJ}$ ) . . . . .	9
<b>Figure 15.</b>	Enable thresholds vs. temperature ( $V_{OUT} = 5\text{ V}$ ) . . . . .	9
<b>Figure 16.</b>	Dropout voltage vs. temperature . . . . .	10
<b>Figure 17.</b>	Quiescent current vs. temperature ( $V_{OUT} = 5\text{ V}$ , $I_{OUT} = 0\text{ mA}$ ) . . . . .	10
<b>Figure 18.</b>	Quiescent current vs. temperature ( $V_{OUT} = 5\text{ V}$ , $I_{OUT} = 600\text{ mA}$ , $1.2\text{ A}$ ) . . . . .	10
<b>Figure 19.</b>	Quiescent current vs. temperature ( $V_{OUT} = V_{ADJ}$ , $I_{OUT} = 0\text{ mA}$ ) . . . . .	10
<b>Figure 20.</b>	Quiescent current vs. temperature ( $V_{OUT} = V_{ADJ}$ , $I_{OUT} = 600\text{ mA}$ ) . . . . .	10
<b>Figure 21.</b>	Quiescent current vs. temperature ( $V_{OUT} = V_{ADJ}$ , $I_{OUT} = 1.2\text{ A}$ ) . . . . .	10
<b>Figure 22.</b>	Off-state current vs. temperature ( $V_{OUT} = 5\text{ V}$ ) . . . . .	11
<b>Figure 23.</b>	Off-state current vs. temperature ( $V_{OUT} = V_{ADJ}$ ) . . . . .	11
<b>Figure 24.</b>	Short-circuit current vs. dropout voltage ( $V_{OUT} = 5\text{ V}$ ) . . . . .	11
<b>Figure 25.</b>	Short-circuit current vs. dropout voltage ( $V_{OUT} = V_{ADJ}$ ) . . . . .	11
<b>Figure 26.</b>	SVR vs. frequency . . . . .	11
<b>Figure 27.</b>	Output noise spectral density ( $V_O = V_{ADJ}$ ) . . . . .	11
<b>Figure 28.</b>	Output noise spectral density ( $V_O = 5\text{ V}$ ) . . . . .	12
<b>Figure 29.</b>	Output noise spectral density ( $V_O = 12\text{ V}$ ) . . . . .	12
<b>Figure 30.</b>	Stability plan ( $V_{OUT} = 5\text{ V}$ ) . . . . .	12
<b>Figure 31.</b>	Stability plan ( $V_{OUT} = V_{ADJ}$ ) . . . . .	12
<b>Figure 32.</b>	Startup with enable ( $V_{OUT} = 5\text{ V}$ ) . . . . .	12
<b>Figure 33.</b>	Startup with enable ( $V_{OUT} = V_{ADJ}$ ) . . . . .	12
<b>Figure 34.</b>	Turn-on time ( $V_{OUT} = 5\text{ V}$ ) . . . . .	13
<b>Figure 35.</b>	Turn-on time ( $V_{OUT} = V_{ADJ}$ ) . . . . .	13
<b>Figure 36.</b>	Line transient ( $V_{OUT} = 5\text{ V}$ ) . . . . .	13
<b>Figure 37.</b>	Line transient ( $V_{OUT} = V_{ADJ}$ ) . . . . .	13
<b>Figure 38.</b>	Load transient ( $V_{OUT} = 5\text{ V}$ ) . . . . .	13
<b>Figure 39.</b>	Load transient ( $V_{OUT} = V_{ADJ}$ ) . . . . .	13
<b>Figure 40.</b>	DFN6 (3x3) package outline . . . . .	14
<b>Figure 41.</b>	DFN6 (3x3) recommended footprint . . . . .	15
<b>Figure 42.</b>	DFN6 (3x3) tape outline . . . . .	16
<b>Figure 43.</b>	DFN6 (3x3) reel outline . . . . .	17
<b>Figure 44.</b>	DFN6 (2x2) package outline . . . . .	18
<b>Figure 45.</b>	DFN6 (2x2) recommended footprint . . . . .	19
<b>Figure 46.</b>	DFN6 (2 x 2 mm) reel outline . . . . .	20
<b>Figure 47.</b>	SO-8 batwing package outline . . . . .	21
<b>Figure 48.</b>	SO-8 batwing recommended footprint . . . . .	22