

LF1206E152R-10

PHYSICAL DIMENSIONS:

- A 3.20 [.126] +0.20 [.008]
- B 1.60 [.063] +0.20 [.008]
- C 1.10 [.043] +0.20 [.008]
- D 0.51 [.020] +0.25 [.010]

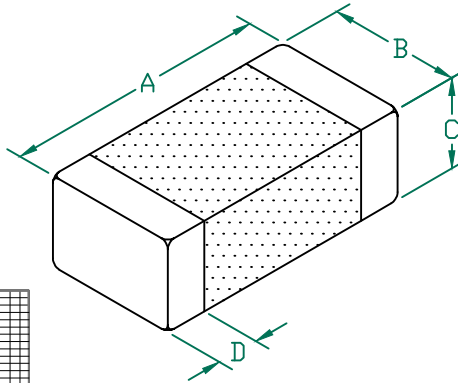

ELECTRICAL CHARACTERISTICS:

Z @ 50MHz (Ω)	DCR (Ω)	Rated Current
Nominal	1500	
Minimum	1125	
Maximum	1875	500 mA

NOTES: UNLESS OTHERWISE SPECIFIED

1. TAPED AND REELED per CURRENT EIA SPECIFICATIONS 7" REELS, 3000 PCS/REEL, EMBOSSED PLASTIC TAPE.
2. COMPONENTS SHOULD BE ADEQUATELY PREHEATED BEFORE SOLDERING.
3. TERMINATION FINISH IS 100% TIN.
4. OPERATING TEMPERATURE: $-40^{\circ}\text{C} \sim +125^{\circ}\text{C}$. (INCLUDING SELF-HEATING)

Z vs FREQUENCY
IMPEDANCE UNDER DC BIAS

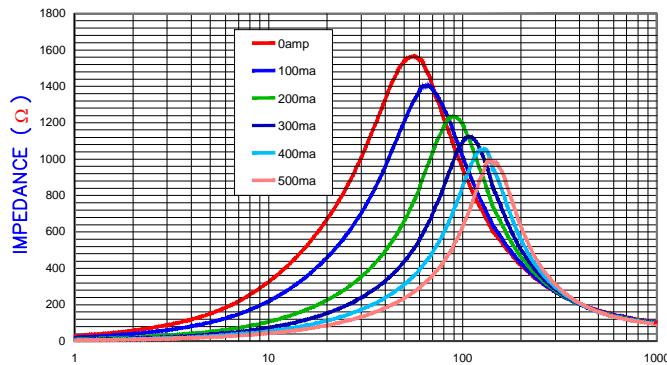

LAND PATTERNS FOR REFLOW SOLDERING

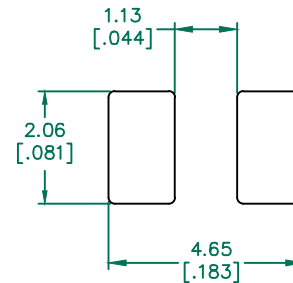

(For wave soldering, add 0.762 [0.030] to this dimension)

RECOMMENDED SOLDERING CONDITIONS

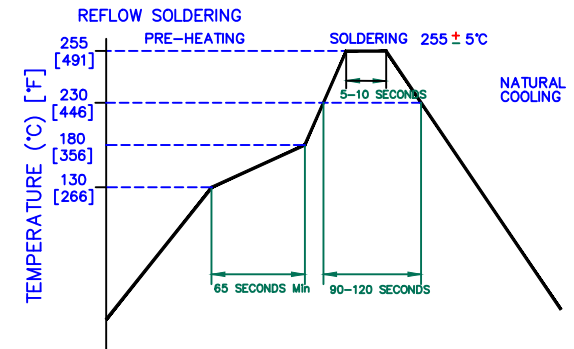

[Z], R, AND X vs. FREQUENCY

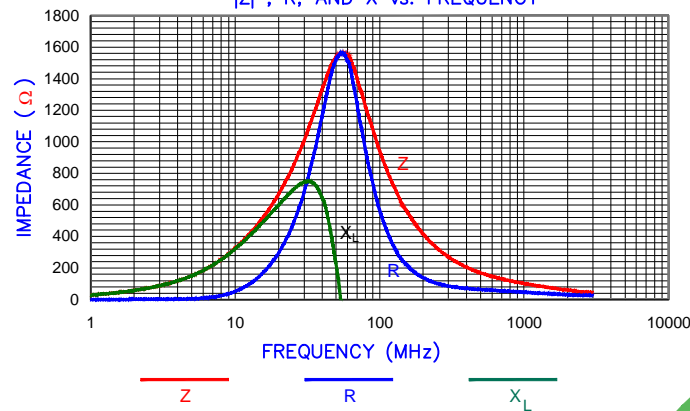

AGILENT E4991A RF Impedance/Material Analyzer
HP 16194A Test Fixture REF. 4405

DIMENSIONS ARE IN mm [INCHES].				This print is the property of Laird Tech. and is loaned in confidence subject to return upon request and with the understanding that no copies shall be made without the written consent of Laird Tech. All rights to design or invention are reserved.			
D	UPDATE LAIRD LOGO AND NOTES 4	08/05/13	QU				
C	ADD OPERATING TEMPERATURE UPDATE Z IMPEDANCE AT 50MHz AND REFLOW	02/19/13	QU				
B	UPDATE COMPANY LOGO & ROHS SYMBOL	07/08/08	JRK	PROJECT/PART NUMBER:	REV	PART TYPE:	DRAWN BY:
A	ORIGINAL DRAFT	09/13/06	JRK	LF1206E152R-10	D	CO-FIRE	JRK
REV	DESCRIPTION	DATE	INT	DATE:	SCALE:	SHEET:	
				09/13/06	NTS		
				CAD #	TOOL #		
				LF1206E152R-10-D	-		1 of 1