

GAPS & HAPS SERIES

000843

Issue 2

Aerospace Proximity Sensors

DESCRIPTION

Honeywell has over 30 years' experience designing and delivering accurate and reliable proximity sensors that are currently used in a variety of military and commercial aircraft.

Honeywell has two new platforms of proximity sensors: **General Aerospace Proximity Sensors (GAPS)** and **Harsh Aerospace Proximity Sensors (HAPS)**, formerly known as the IHM Series. Both platforms incorporate Honeywell's patented Internal Health Monitoring functionality, however the products have some technical differences that allow them to be used in various aerospace applications. GAPS can be used in less harsh areas of application with some differences of electrical and environmental characteristics when compared to HAPS. Whilst, HAPS Aerospace Proximity Sensors are configurable, non-contact, hermetically sealed devices designed to sense the presence or absence of a target in harsh-duty aircraft applications.

The GAPS and HAPS platforms provide on/off outputs and can be configured with an optional health monitoring output to the host system. The sensing mechanism is based on the familiar Eddy Current Killed Oscillator (ECKO) principles; however, Honeywell has designed and implemented the patented FAVCO (Fixed Amplitude Variable Current Oscillator) technology which enables the Honeywell sensors to have the health monitoring (IHM) features. See Figure 5 to compare the ECKO and FAVCO technologies. The GAPS and HAPS Series helps to reduce downtime and maintenance costs due to a unique circuit that can detect any internal failures and display a fault output instead of a false positive or false negative. For the customer, this delivers the best performance with a lower overall cost over the life of the aircraft.

FEATURES

- Industry-leading indirect lightning and dielectric ruggedness: Meets the increased requirements of today's composite aircraft and most challenging applications including landing gear, thrust reversers, and flight controls
- Enhanced vibration ruggedness: Capable of withstanding extremely high vibration applications
- Environmentally rugged: Fully hermetic packages provide long-term reliability in very harsh environments by eliminating the potential for contamination of the sensor from the application environment. In addition, Honeywell has developed an innovative method to environmentally seal wire-lead (pigtail) configurations
- Internal Health Monitoring Capability: Optional third output state to indicate the health of the sensor (whether it is healthy or failed). Reduces maintenance time, reduces delayed flights, and lowers overall maintenance cost across the life of the aircraft
- Non-contact design: Utilizes non-contact technology to sense the presence or absence of a target regardless of the dirty, harsh environment in which it is placed, eliminating mechanical failure mechanisms, reducing wear, minimizing downtime, increasing durability, and increasing reliability



VALUE TO CUSTOMERS

- Enhanced vibration and EMI specifications help to increase revenue (flight hours) and reduce cost to serve (system maintenance)
- Hermetic sealing helps increase revenue (flight hours), reduce cost to serve (maintenance), & reduce cost of goods (spares)
- Platform approach helps to increase revenue and reduce cost to serve
- Health monitoring helps to increase revenue, reduce cost to serve, and reduce cost of goods
- Supplier stability helps to reduce cost to serve (troubleshoot with original supplier)
- Current install base helps to reduce cost to serve (proven performance and MTBF)

PORTFOLIO



Honeywell's GAPS and HAPS Series is part of a comprehensive line of aerospace sensors, switches, and value-added solutions.

To view Honeywell's complete product offering, click here.

Honeywell

AEROSPACE PROXIMITY SENSORS, GAPS & HAPS SERIES



GAPS | GENERAL Aerospace Proximity Sensor

HAPS | HARSH Application Proximity Sensor

Landing Gear GAPS	Doors GAPS	Hydraulics GAPS	Primary Surface GAPS	Rear Stabilizer GAPS	Gen Actuators GAPS	TRAS HAPS	Valves HAPS	Engine HAPS
Ground Vehicles GAPS	Airframe GAPS	Rotary Actuators GAPS	Evacuation Slides GAPS	Cargo Storage GAPS	Turbine Speed/ACM GAPS	Actuators HAPS	Nacelle HAPS	Canopies HAPS

GAPS

DIFFERENTIATORS

HAPS

500,000	MTBF > FLIGHT HOURS	500,000
	MECHANICAL CHARACTERISTICS	
115°C	OPERATING TEMPERATURE	115°C
20 G	VIBRATION	90 G
20 G	OPERATING SHOCK	20 G
	ELECTRICAL CHARACTERISTICS	
150 mA Level W	RADIO FREQUENCY CONDUCTED SUSCEPTIBILITY	300 mA Level Y
100 V/m CAT F	RADIO FREQUENCY RADIATED SUSCEPTIBILITY	200 V/m CAT G
Level 3	LIGHTNING INDUCED TRANSIENT SUSCEPTIBILITY	Level 3
Current loop output with Internal Health Monitoring (IHM) NPN open collector output max. load current 20 mA	OUTPUT TYPE	Current loop output with Internal Health Monitoring (IHM) NPN open collector output max. load current 250 mA
1000 Vdc/750 Vac	DIELECTRIC/IR	1000 Vdc/750 Vac

AEROSPACE PROXIMITY SENSORS, GAPS & HAPS SERIES

TABLE 1. GAPS SERIES AND HAPS SERIES PERFORMANCE SPECIFICATIONS

CHARACTERISTIC	PARAMETER	
Mechanical Characteristics	GAPS	HAPS
Weight	Less than 60 grams (inline variants); 85 grams (right-angle variants)	60 g to 150 g
Sealing	Hermetically sealed	Hermetically sealed, pigtail versions environmentally sealed
Connector/leads	D38999/25YA98PN D38999/25YA98PA EN2997Y10803MN	<ul style="list-style-type: none"> • D38999/25YA98PN • EN2997Y10803MN • M83723/90Y10056 • M83723/90Y10058 • D38999/25YA98PA • M83723/90Y1005N • M83723/90Y10057 • Pigtail
Form factor	<ul style="list-style-type: none"> • Inline, cylindrical, threaded • Right angle, cylindrical, threaded • Inline, cylindrical, flanged • Right angle, cylindrical, flanged 	<ul style="list-style-type: none"> • Inline, cylindrical, threaded • Right angle, cylindrical, threaded • Inline, cylindrical, flanged • Right angle, cylindrical, flanged
Sensing distance	3,5 mm max.	4 mm max.
Sensing face	Inconel®	Inconel®
Outer body material	Stainless steel	Stainless steel
Sensor head diameter	13,5 mm [0.53 in]	13,5 mm [0.53 in]
Sensor length	55 mm [2.17 in] max.	various; 60 mm [2.36 in] max.
Target (typical)	SS 17-4PH rectangular target with dimensions 25 mm x 18 mm x 3 mm [0.98 in x 0.71 in x 0.12 in]	SS 17-4PH rectangular target with dimensions 25 mm x 18 mm x 3 mm [0.98 in x 0.71 in x 0.12 in]
MTBF	500,000 flight hours	500,000 flight hours
Electrical Characteristics	GAPS	HAPS
Supply voltage	12 Vdc to 32 Vdc (input)	12 Vdc to 32 Vdc (input)
Supply current	<10 mA	<10 mA
Operating temperature range	-55°C to 115°C [-67°F to 239°F]	-55°C to 115°C [-67°F to 239°F]
Storage temperature range	-65°C to 115°C [-85°F to 239°F]	-65°C to 115°C [-85°F to 239°F]
Target response time	5 ms	5 ms
Power on delay time	<1 second	<1 second
Bonding resistance	< 2.5 mΩ	<2.5 mΩ
Dielectric strength	1000 Vdc/750 Vac for 1 minute	1000 Vdc/750 Vac for 1 minute
Insulation resistance	200 MΩ min. at 50 Vdc	200 MΩ min. at 50 Vdc
Sensing Characteristics	GAPS	HAPS
Ga/Gd	see Figure 3	see Figure 3
Target material	17-4 PH stainless steel heat treated to condition H1025	17-4 PH stainless steel heat treated to condition H1025
Target dimension	Rectangular target of 25 mm x 18 mm x 3 mm	Rectangular target of 25 mm x 18 mm x 3 mm

AEROSPACE PROXIMITY SENSORS, GAPS & HAPS SERIES

TABLE 2. GAPS SERIES AND HAPS SERIES PERFORMANCE SPECIFICATIONS

CHARACTERISTIC	PARAMETER	
Environmental Characteristics	GAPS	HAPS
Temperature and altitude	RTCA/DO-160G – Section 4, Category D3	RTCA/DO-160G – Section 4, Category D3
Temperature variation	RTCA/DO-160G – Section 5, Category S2	RTCA/DO-160G – Section 5, Category S2
Humidity	RTCA/DO-160G – Section 6, Category C	RTCA/DO-160G – Section 6, Category C
Operational shock and crash safety	RTCA/DO-160G – Section 7, Category B	RTCA/DO-160G – Section 7, Category B
Vibration	RTCA/DO-160G – Section 8, Category R (Curve E, E1, and W)	RTCA/DO-160G – Section 8, Category R (Curve E, E1, and W)
Explosion safety	RTCA/DO-160G – Section 9 Category H	RTCA/DO-160G – Section 9 Category E & H
Water proofness	RTCA/DO-160G – Section 10, Category R	RTCA/DO-160G – Section 10, Category R
Fire proofness	CPR option (Case Pressure Relief Port) (GAPS only)	Standard
Fluid susceptibility	RTCA/DO-160G – Section 11, Category F	RTCA/DO-160G – Section 11, Category F
Sand and dust	RTCA/DO-160G – Section 12, Category D	RTCA/DO-160G – Section 12, Category D
Fungus resistance	RTCA/DO-160G – Section 13, Category F	RTCA/DO-160G – Section 13, Category F
Salt spray	RTCA/DO-160G – Section 14, Category T	RTCA/DO-160G – Section 14, Category T
Magnetic effects	RTCA/DO-160G – Section 15, Category A	RTCA/DO-160G – Section 15, Category A
Power input	RTCA/DO-160G – Section 16, Category A	RTCA/DO-160G – Section 16, Category A
Voltage spike	RTCA/DO-160G – Section 17, Category A	RTCA/DO-160G – Section 17, Category A
Audio frequency conducted susceptibility	RTCA/DO-160G – Section 18, Category Z	RTCA/DO-160G – Section 18, Category Z
Induced signal susceptibility	RTCA/DO-160G – Section 19, Category CWE	RTCA/DO-160G – Section 19, Category CWE
Radio frequency radiated susceptibility	RTCA/DO-160G – Section 20, Category F	RTCA/DO-160G – Section 20, Category G
Radio frequency conducted susceptibility	RTCA/DO-160G – Section 20, Category W	RTCA/DO-160G – Section 20, Category Y
Radio frequency emission	RTCA/DO-160G – Section 21, Category M	RTCA/DO-160G – Section 21, Category M
Lightning induced transient susceptibility	RTCA/DO-160G – Section 22, Category B3K3L3	RTCA/DO-160G – Section 22, Category B3K3L3
Icing	RTCA/DO-160G – Section 24, Category A	RTCA/DO-160G – Section 24, Category A
Electrostatic discharge	RTCA/DO-160G – Section 25, Category A	RTCA/DO-160G – Section 25, Category A

AEROSPACE PROXIMITY SENSORS, GAPS & HAPS SERIES

FIGURE 1. GAPS PRODUCT NOMENCLATURE

Series	Form Factor	Range Ga/Gd mm [in]	Electrical Output Type	Termination	Reserved	Hardware	Reserved for customization
LG Series General Aerospace Proximity Sensor	CT Inline, cylindrical threaded	A 1.75/2.75 [0.069/0.108]	3C 3-wire, open collector output normally open	A D38999/25YA98PN	0	N No hardware	
	RT Right angle cylindrical threaded	B 2.00/3.00 [0.078/0.118]	3A 3-wire, current sink output*	B D38999/25YA98PA		1 With hardware	
	CF Inline, cylindrical flanged*	C 2.25/3.25 [0.088/0.128]	3B 3-wire, open collector output normally closed*	C EN2997Y10803MN*			
	RF Right angle cylindrical flanged*	D 2.50/3.50 [0.098/0.138]		D Custom connector*			
		E 2.75/3.75 [0.108/0.148]*					
		F 3.00/4.00 [0.118/0.157]*					
		Z Custom*					

*Note: These grayed-out options with blue code letters are non-qualified listings (not released as production listings in Honeywell's system for ordering). These listings will be qualified upon customer request. A project needs to be raised to qualify these listings based on customer request and related documents to be revised (PRS, QTP, etc.).

FIGURE 2. HAPS SERIES PRODUCT NOMENCLATURE

Series	Form Factor	Range Ga/Gd mm [in]	Electrical Output Type	Termination	Pigtail Length	Hardware	Reserved
HAPS Series One-Piece (Active) Proximity Sensor	CT Inline, cylindrical threaded	A 1.75/2.75 [0.069/0.108]	3A 3-wire, current sink output Near/Fault/Far	A D38999/25YA98PN	N Not applicable	N No hardware	
	RT Right angle cylindrical threaded	B 2.00/3.00 [0.078/0.118]	3B 3-wire, open collector output normally closed	B D38999/25YA98PA	A 30.84 cm [12.0 in]	1 Washer MS25081C6 (1 nos.) Hex nut MS21340-05 (2 nos.)	
	CF Inline, cylindrical flanged	C 2.25/3.25 [0.088/0.128]	3C 3-wire, open collector output normally open	C EN2997Y10803MN	B 60.96 cm [24.0 in]		
	RF Right angle cylindrical flanged	D 2.50/3.50 [0.098/0.138]		H Pigtail (flying lead)	C 91.44 cm [36.0 in]		
		E 2.75/3.75 [0.108/0.147]		D M83723/90Y1005N*	D 121.92 cm [48.0 in]		
		F 3.00/4.00 [0.118/0.157]		E M83723/90Y10056*	E 152.40 cm [60.0 in]		
				F M83723/90Y10057*	F 182.88 cm [72.0 in]		
			G M83723/90Y10058*	G 213.36 cm [84.0 in]			

*Note: These grayed-out options are non-qualified listings (not released as production listings in the ordering system). These listings will be qualified based on customer request. Contact Honeywell for further information on the grayed-out customization options.

AEROSPACE PROXIMITY SENSORS, GAPS & HAPS SERIES

TABLE 3. GAPS SERIES INTERFACE DETAILS

SUPPLY VOLTAGE	SUPPLY CURRENT	OUTPUT TYPE	OUTPUT CONDITION	CONNECTOR	CATALOG LISTING	PIN CONFIGURATION
12 Vdc to 32 Vdc	10 mA max.	Current sink	Target near: $4 \text{ mA} \leq I_o \leq 6 \text{ mA}$ Target far: $12 \text{ mA} \leq I_o \leq 16 \text{ mA}$ Internal fault: $9 \text{ mA} \leq I_o \leq 11 \text{ mA}$ or $I_o < 1 \text{ mA}$	D38999/25YA98PN	LGXXD3AAX-000	Pin A: Supply excitation Pin B: Supply return Pin C: Output
				D38999/25YA98PA	LGXXD3ABX-000	Pin A: Supply excitation Pin B: Supply return Pin C: Output
				EN2997Y10803MN	LGXXD3ACX-000	Pin 1: Supply excitation Pin 2: Supply return Pin 3: Output
12 Vdc to 32 Vdc	10 mA max.	Open collector (normally closed)	Target near: Switch open, $I_o < 100 \mu\text{A}$ Target far: Switch close, $V_o < 1 \text{ V}$ @ 20 mA of I_o	D38999/25YA98PN	LGXXD3BAX-000	Pin A: Supply excitation Pin B: Supply return Pin C: Output
				D38999/25YA98PA	LGXXD3BBX-000	Pin A: Supply excitation Pin B: Supply return Pin C: Output
				EN2997Y10803MN	LGXXD3BCX-000	Pin 1: Supply excitation Pin 2: Supply return Pin 3: Output
12 Vdc to 32 Vdc	10 mA max.	Open collector (normally open)	Target near: Switch close, $V_o < 1 \text{ V}$ @ 20 mA of I_o Target far: Switch open, $I_o < 100 \mu\text{A}$	D38999/25YA98PN	LGXXD3CAX-000	Pin A: Supply excitation Pin B: Supply return Pin C: Output
				D38999/25YA98PA	LGXXD3CBX-000	Pin A: Supply excitation Pin B: Supply return Pin C: Output
				EN2997Y10803MN	LGXXD3CCX-000	Pin 1: Supply excitation Pin 2: Supply return Pin 3: Output

AEROSPACE PROXIMITY SENSORS, GAPS & HAPS SERIES

TABLE 4. HAPS SERIES INTERFACE DETAILS

SUPPLY VOLTAGE	SUPPLY CURRENT	OUTPUT TYPE	OUTPUT CONDITION	CONNECTOR	CATALOG LISTING	PIN/WIRE CONFIGURATION
12 Vdc to 32 Vdc	10 mA max.	Current sink	Target near: $4\text{ mA} \leq I_o \leq 6\text{ mA}$ Target far: $12\text{ mA} \leq I_o \leq 16\text{ mA}$ Internal fault: $9\text{ mA} \leq I_o \leq 11\text{ mA}$ or $I_o < 1\text{ mA}$	D38999/25YA98PN	1PXXX3AANX-000	Pin A: Supply excitation Pin B: Supply return Pin C: Output
				D38999/25YA98PA	1PXXX3ABNX-000	
				EN2997Y10803MN	1PXXX3ACNX-000	Pin 1: Supply excitation Pin 2: Output Pin 3: Supply return
				M83723/90Y1005N	1PXXX3ADNX-000	Pin 1: Supply excitation Pin 2: Output Pin 3: Supply return Pin 4: No connection Pin 5: No connection
				M83723/90Y10056	1PXXX3AENX-000	
				M83723/90Y10057	1PXXX3AFNX-000	
Pigtail (Flying Lead)	1PXXX3AHXX-000	White wire (orange stripes): Supply excitation White wire (blue stripes): Output White wire (no stripes): Supply return				
12 Vdc to 32 Vdc	10 mA max.	Open collector (normally closed)	Target near: Switch open, $I_o < 50\text{ }\mu\text{A}$ Target far: Switch close, $V_o < 1\text{ V}$ @ 20 mA of I_o	D38999/25YA98PN	1PXXX3AANX-000	Pin A: Supply excitation Pin B: Output Pin C: Supply return
				D38999/25YA98PA	1PXXX3ABNX-000	
				EN2997Y10803MN	1PXXX3ACNX-000	Pin 1: Supply excitation Pin 2: Output Pin 3: Supply return
				M83723/90Y1005N	1PXXX3ADNX-000	Pin 1: Supply excitation Pin 2: Output Pin 3: Supply return Pin 4: No connection Pin 5: No connection
				M83723/90Y10056	1PXXX3AENX-000	
				M83723/90Y10057	1PXXX3AFNX-000	
Pigtail (Flying Lead)	1PXXX3AHXX-000	White wire (orange stripes): Supply excitation White wire (blue stripes): Output White wire (no stripes): Supply return				
12 Vdc to 32 Vdc	10 mA max.	Open collector (normally open)	Target near: Switch close, $V_o < 1\text{ V}$ @ 20 mA of I_o Target far: Switch open, $I_o < 50\text{ }\mu\text{A}$	D38999/25YA98PN	1PXXX3AANX-000	Pin A: Supply excitation Pin B: Output Pin C: Supply return
				D38999/25YA98PA	1PXXX3ABNX-000	
				EN2997Y10803MN	1PXXX3ACNX-000	Pin 1: Supply excitation Pin 2: Output Pin 3: Supply Return
				M83723/90Y1005N	1PXXX3ADNX-000	Pin 1: Supply excitation Pin 2: Output Pin 3: Supply return Pin 4: No connection Pin 5: No connection
				M83723/90Y10056	1PXXX3AENX-000	
				M83723/90Y10057	1PXXX3AFNX-000	
Pigtail (Flying Lead)	1PXXX3AHXX-000	White wire (orange stripes): Supply excitation White wire (blue stripes): Output White wire (no stripes): Supply return				

AEROSPACE PROXIMITY SENSORS, GAPS & HAPS SERIES

FIGURE 3. SLIDE-BY CURVES

Proximity Sensor Actuation and De-Actuation Curves

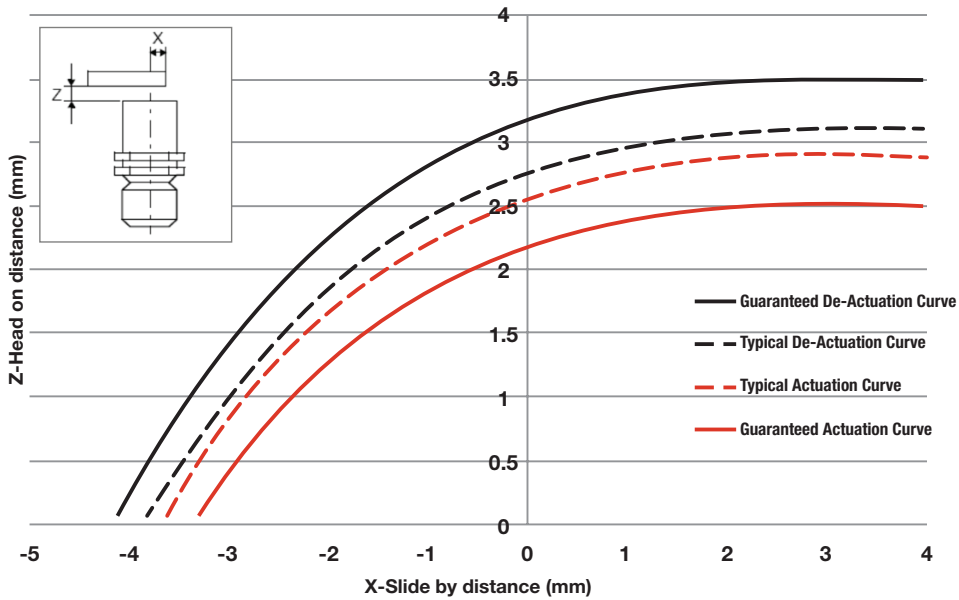
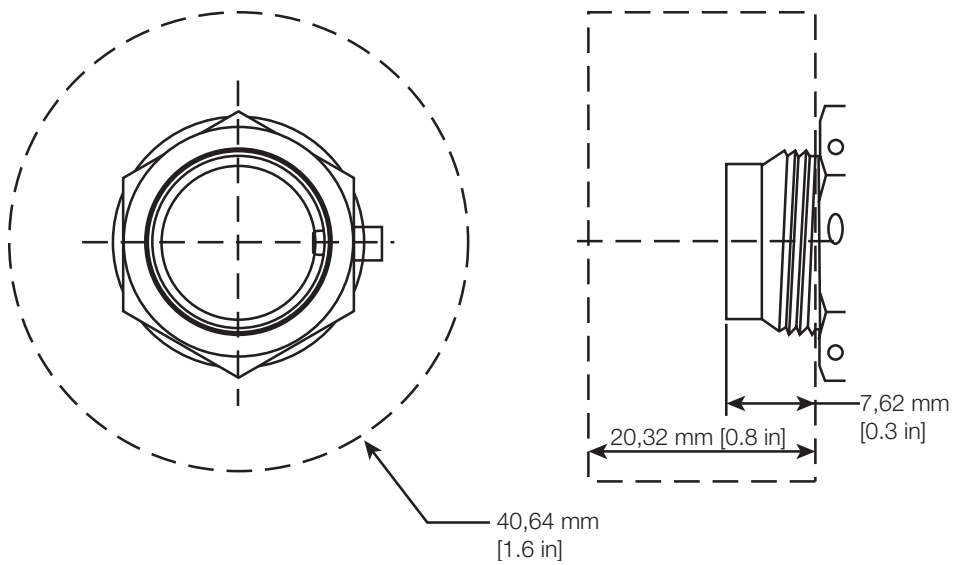
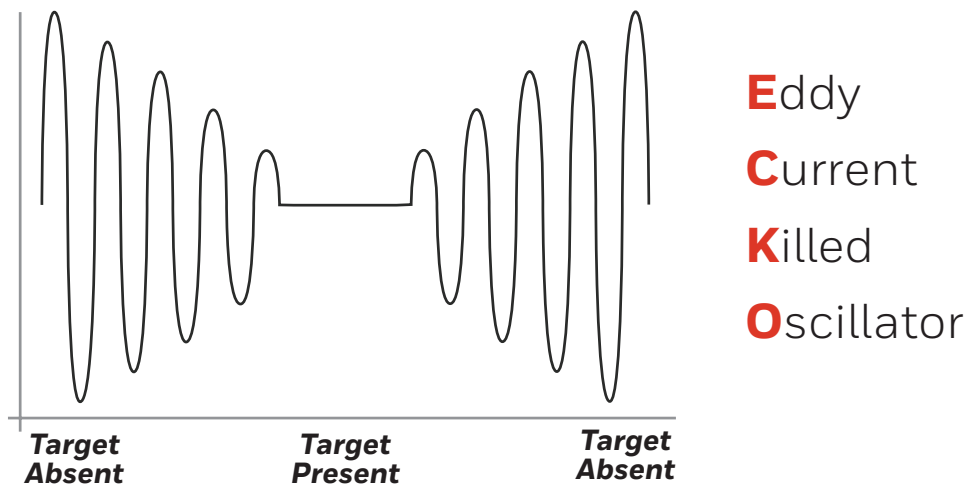

FIGURE 4. KEEP OUT ZONE MAP



AEROSPACE PROXIMITY SENSORS, GAPS & HAPS SERIES

FIGURE 5. ECKO VS. FAVCO TECHNOLOGY



Eddy currents within the target cause a load on the sensor decreasing the amplitude of the oscillator, monitored by a trigger switching the output state **on** or **off**.

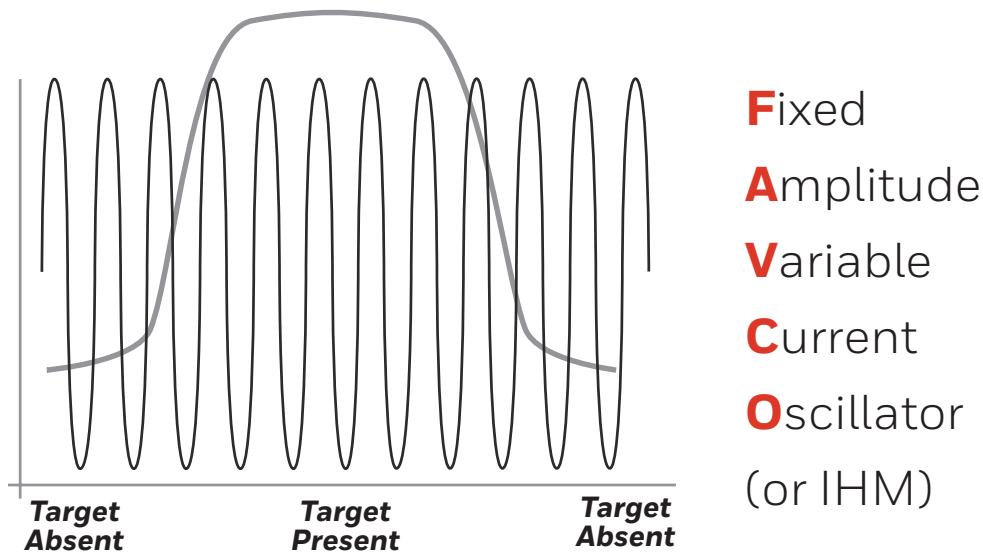

Energy measured to maintain the oscillation when a load on the sensor is applied caused by the eddy currents of the target.

AEROSPACE PROXIMITY SENSORS, GAPS & HAPS SERIES

GAPS WIRING DIAGRAMS

FIGURE 6. GAPS SERIES D38999/25YA98PN CONNECTOR

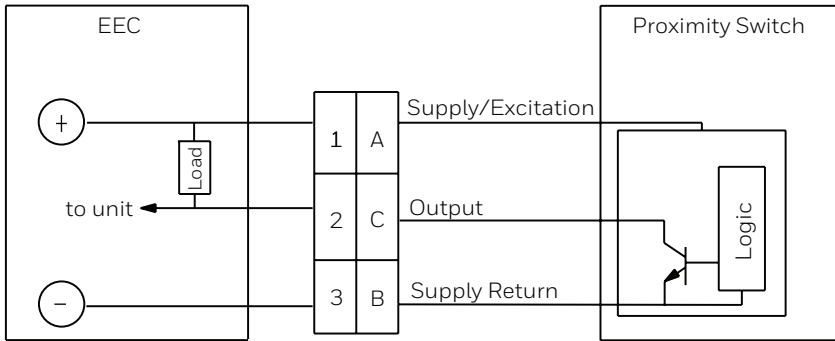
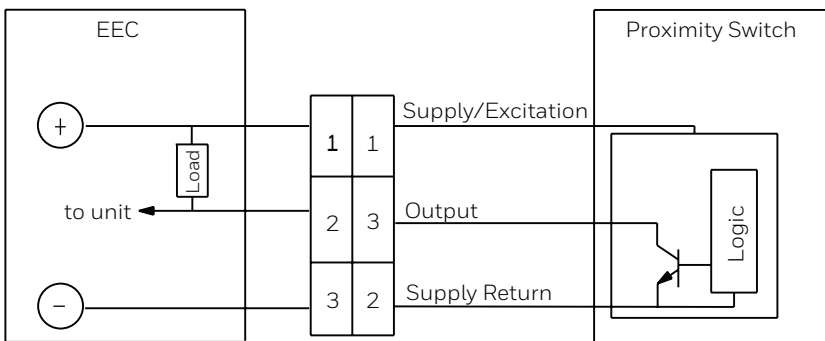
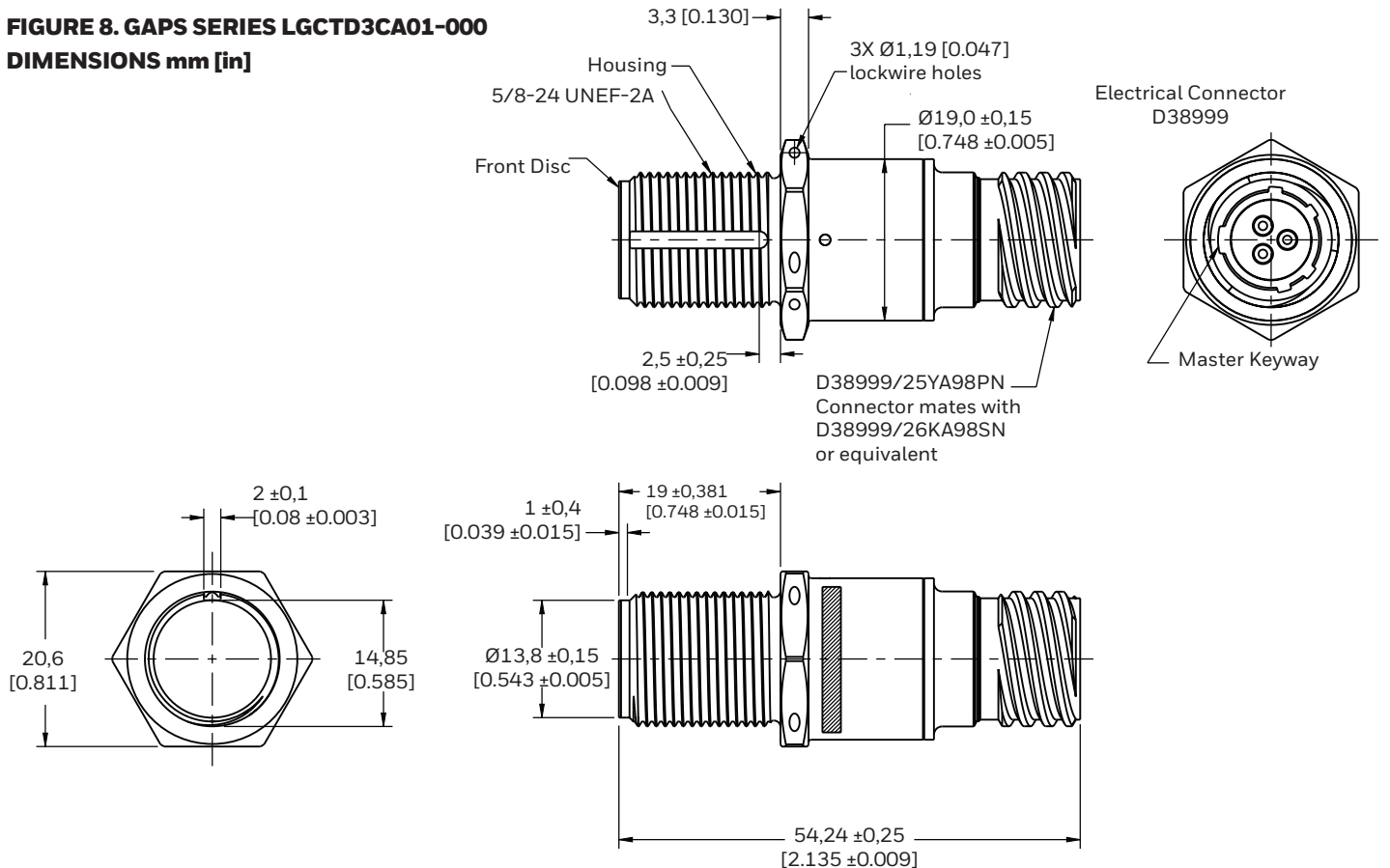

FIGURE 7. GAPS SERIES EN2997Y10803MN CONNECTOR



PRODUCT DIMENSIONS

FIGURE 8. GAPS SERIES LGCTD3CA01-000 DIMENSIONS mm [in]



AEROSPACE PROXIMITY SENSORS, GAPS & HAPS SERIES

FIGURE 9. GAPS SERIES LGCTD3CB01-000 DIMENSIONS mm [in]

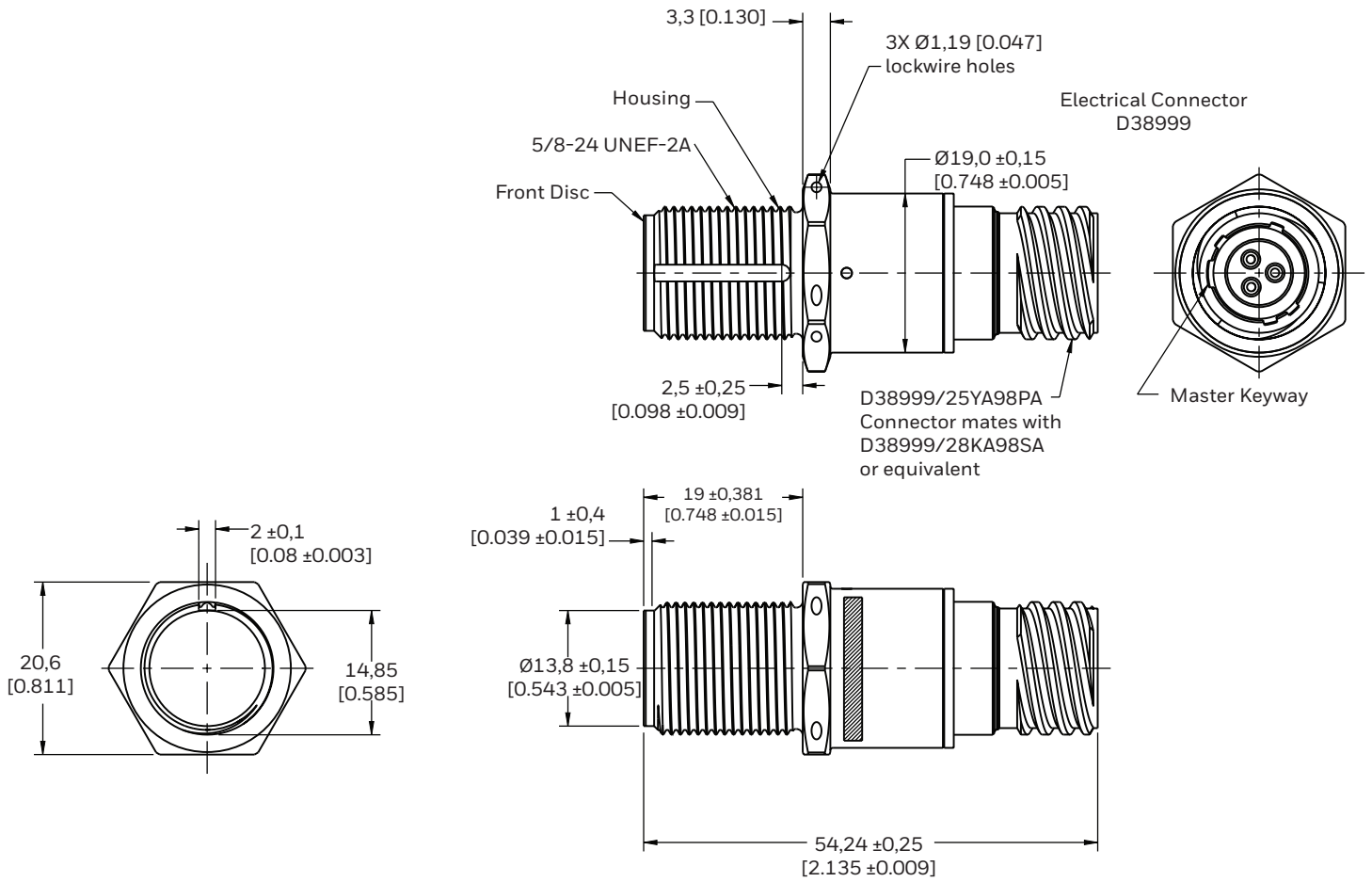

AEROSPACE PROXIMITY SENSORS, GAPS & HAPS SERIES

FIGURE 10. GAPS SERIES LGRTD3CA01-000 DIMENSIONS mm [in]

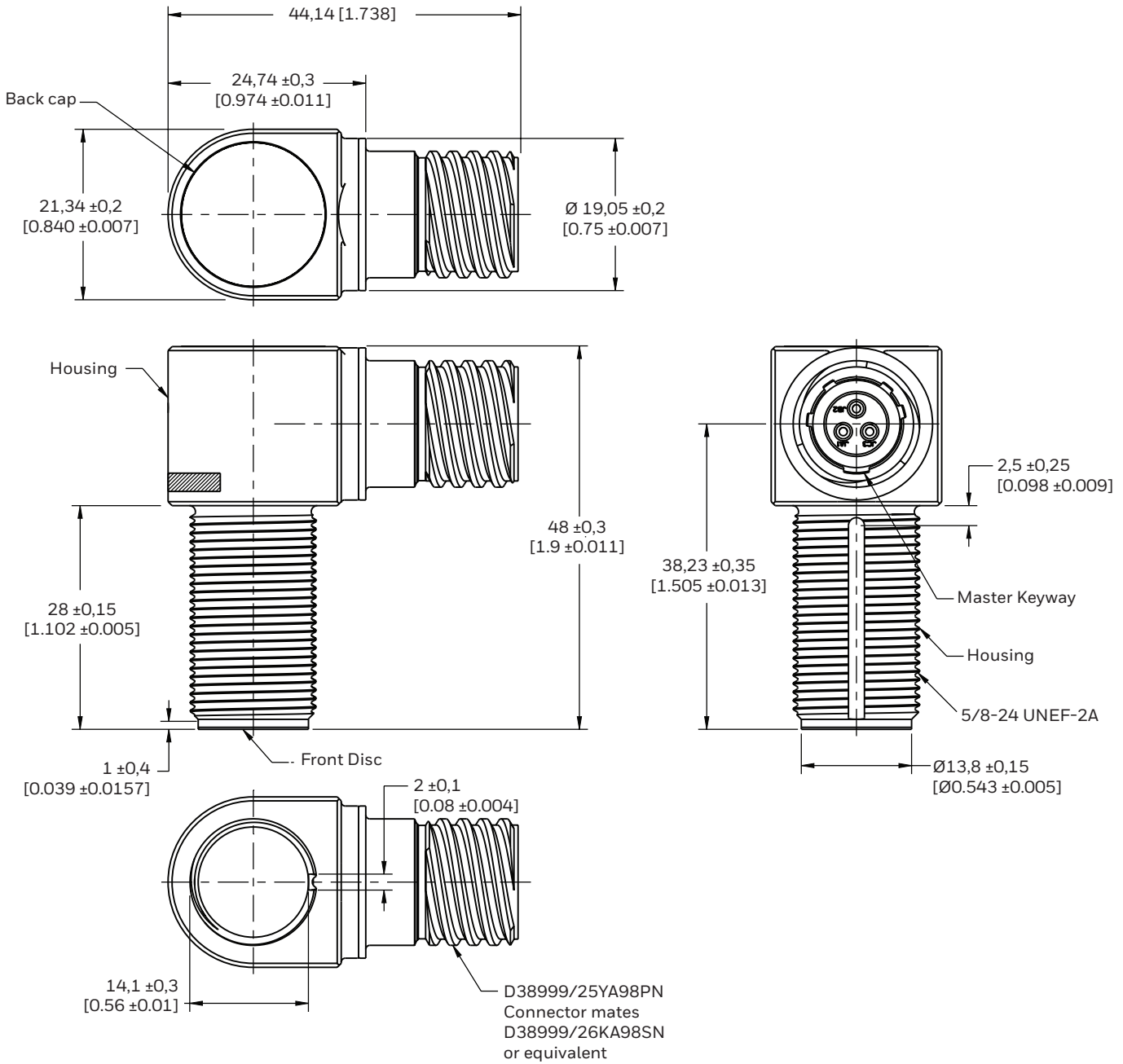

AEROSPACE PROXIMITY SENSORS, GAPS & HAPS SERIES

FIGURE 11. HAPS SERIES: CYLINDRICAL, FLANGED HOUSING WITH EN2997Y10803MN CONNECTOR mm [in]

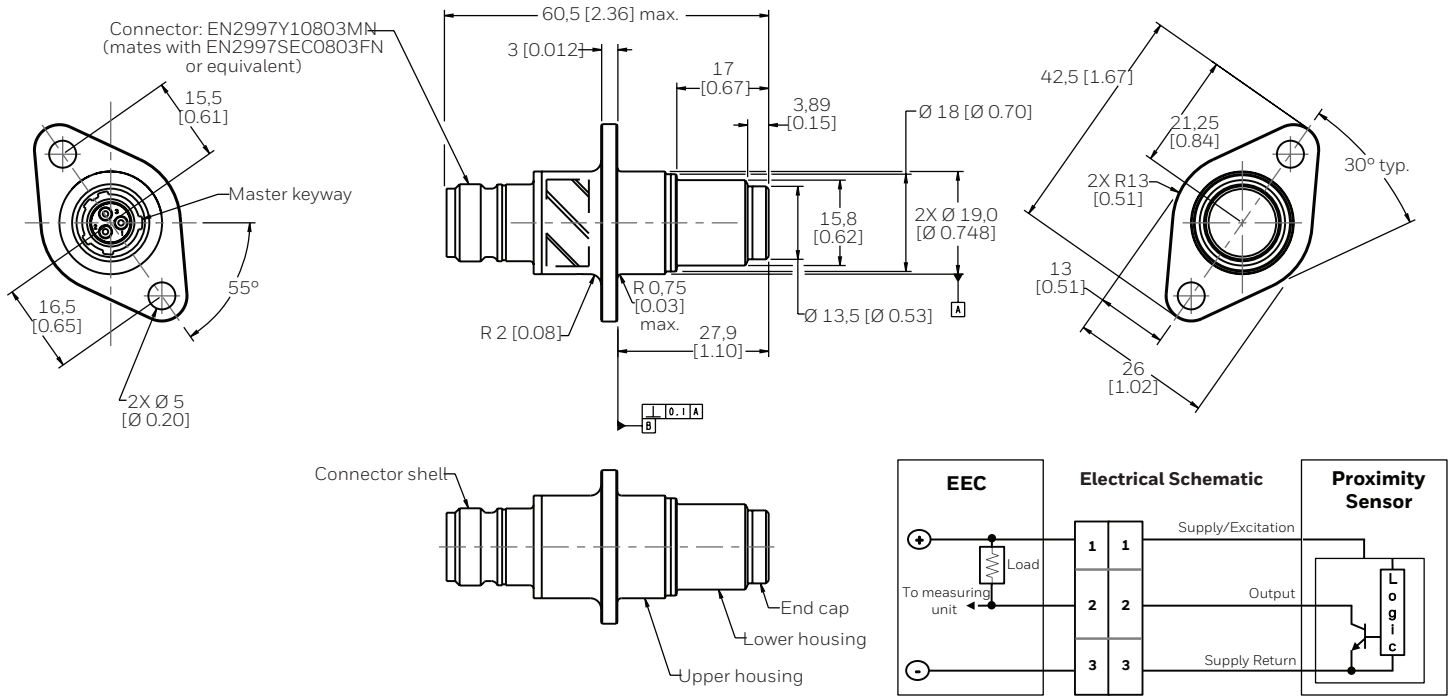
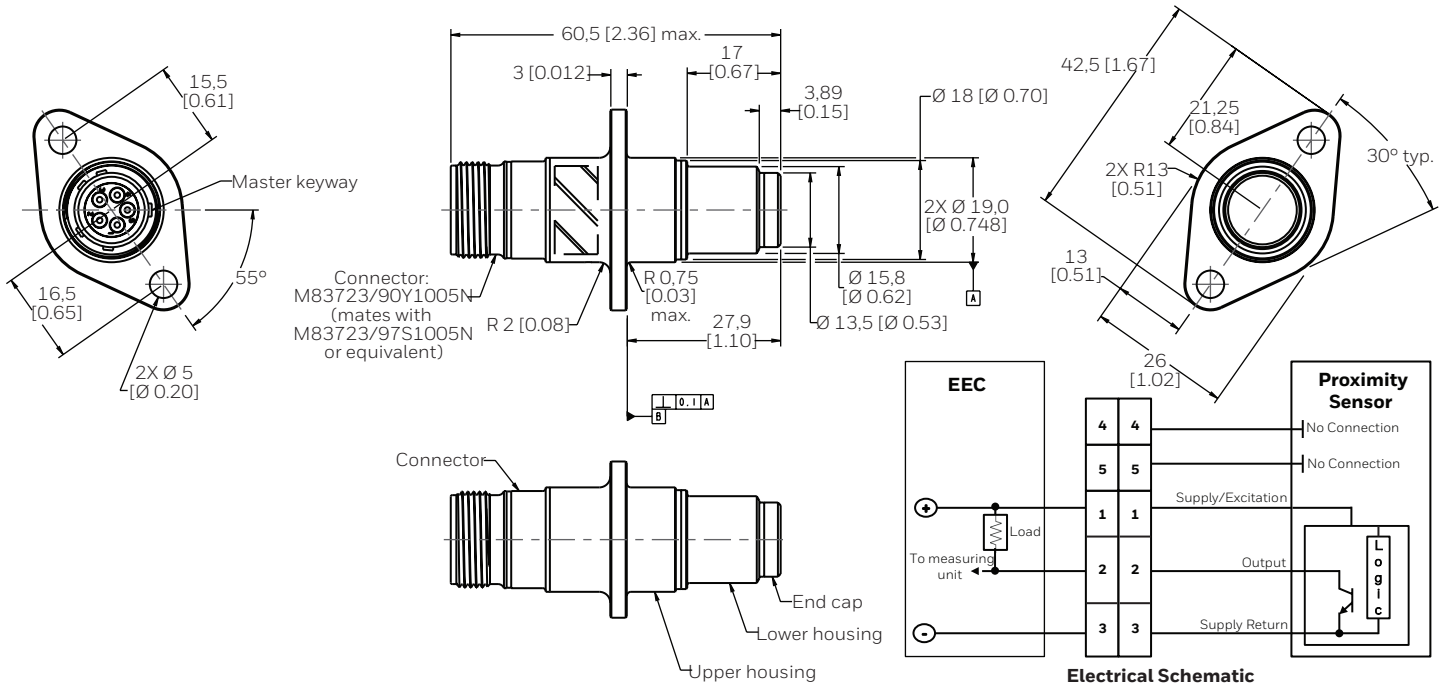

FIGURE 12. HAPS SERIES: CYLINDRICAL, FLANGED HOUSING WITH M83723/90Y1005N CONNECTOR mm [in]



AEROSPACE PROXIMITY SENSORS, GAPS & HAPS SERIES

FIGURE 13. HAPS SERIES: CYLINDRICAL HOUSING WITH D38999/25YA98PN CONNECTOR mm [in]

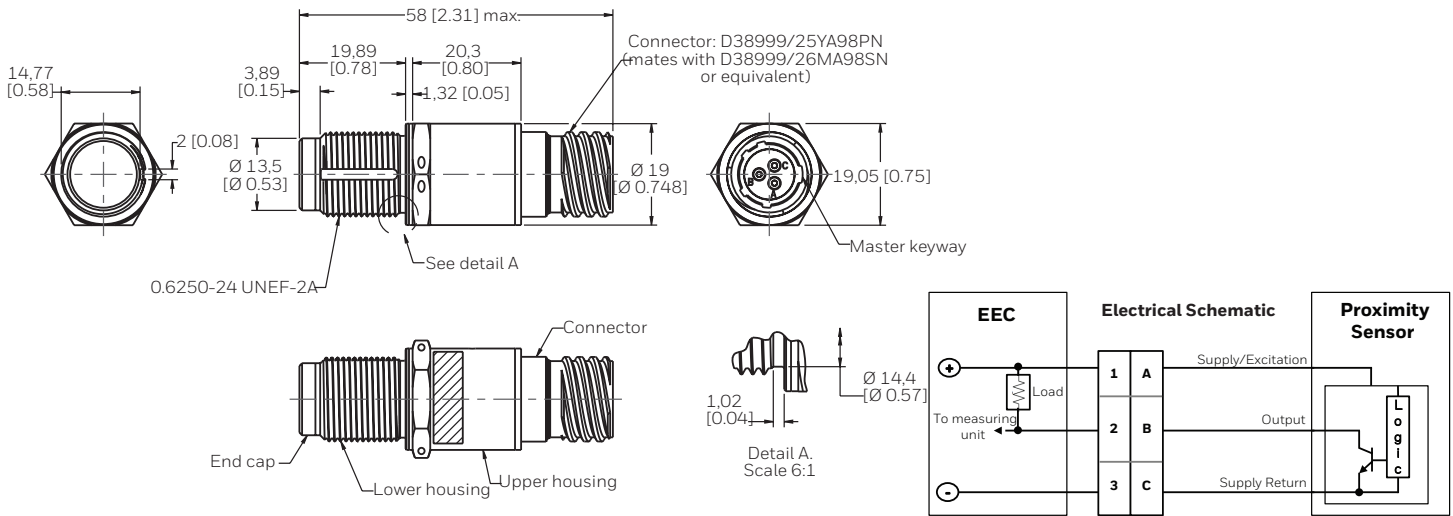
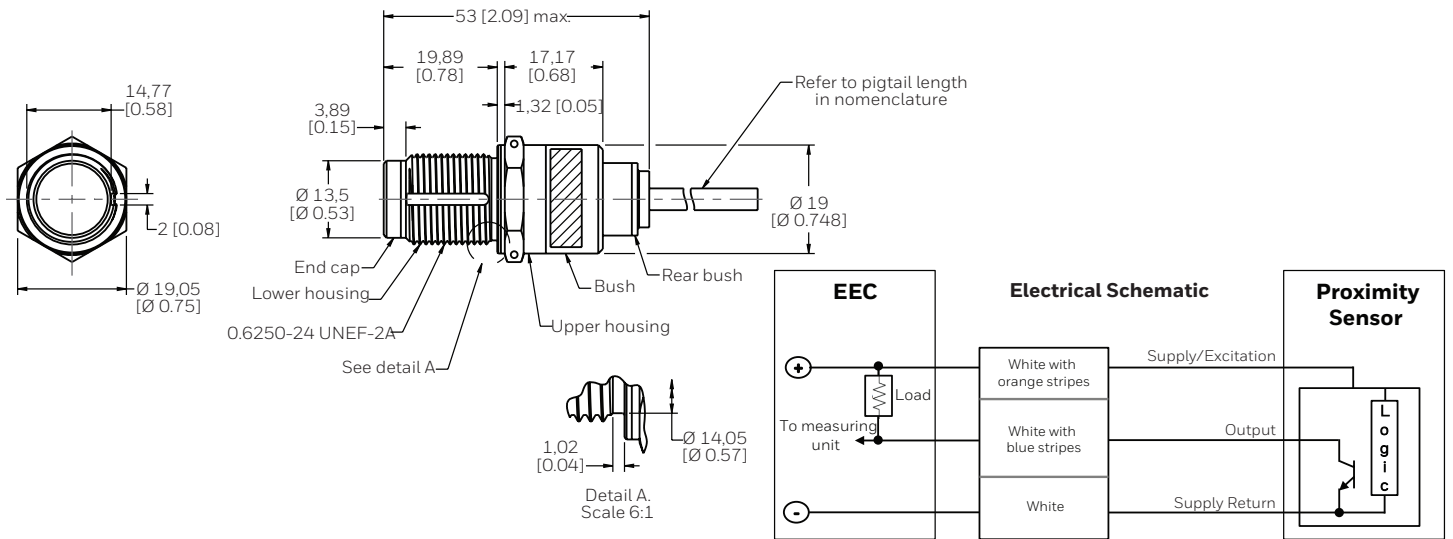

FIGURE 14. HAPS SERIES: CYLINDRICAL HOUSING WITH PIGTAIL CONNECTION mm [in]



AEROSPACE PROXIMITY SENSORS, GAPS & HAPS SERIES

FIGURE 15. HAPS SERIES: RIGHT ANGLE, FLANGED HOUSING WITH D38999/25YA98PN CONNECTOR mm [in]

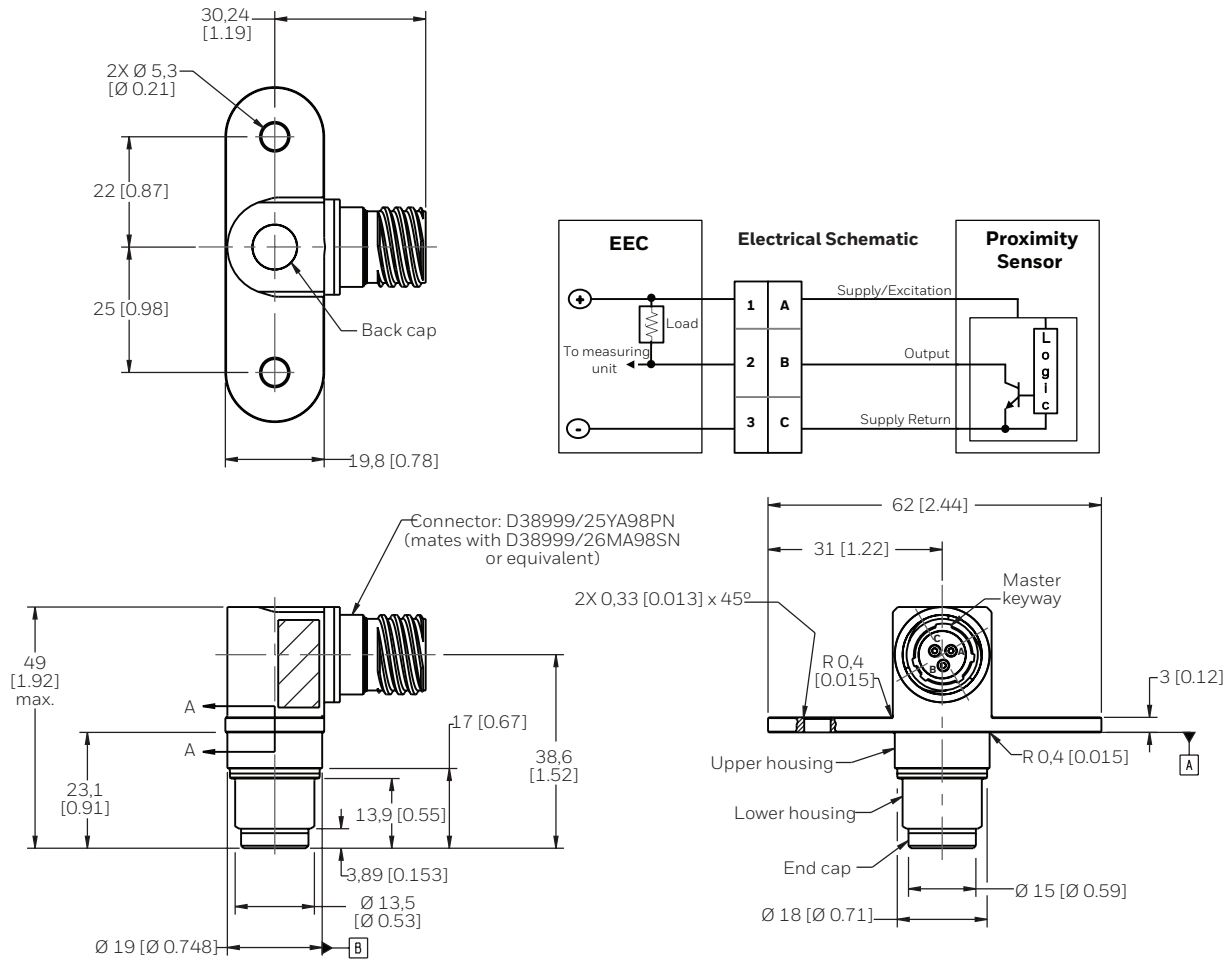
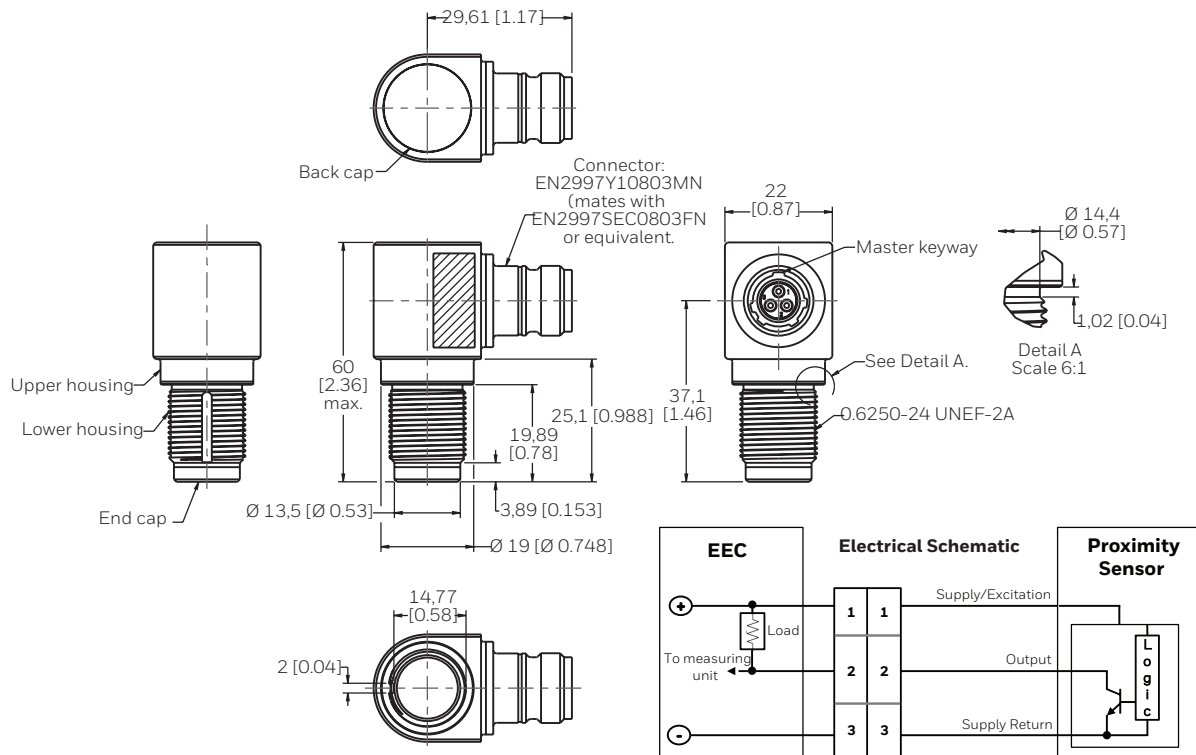

FIGURE 16. HAPS SERIES: RIGHT ANGLE WITH EN2997Y10803MN CONNECTOR mm [in]



AEROSPACE PROXIMITY SENSORS, GAPS & HAPS SERIES

FIGURE 17. HAPS SERIES: RIGHT ANGLE, FLANGED HOUSING WITH PIGTAIL CONNECTION mm [in]

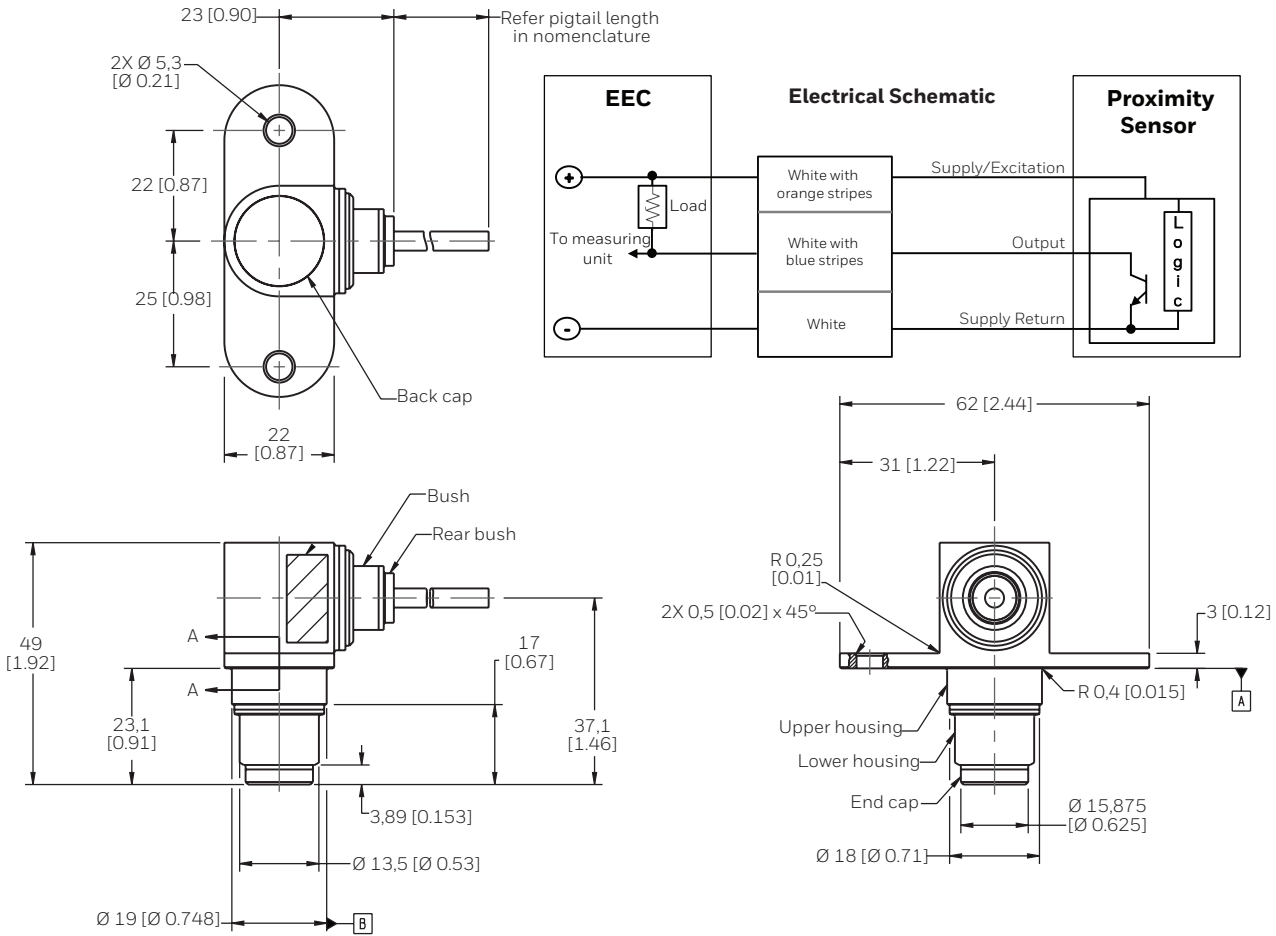

FIGURE 18. HAPS SERIES: RIGHT ANGLE WITH M83723/90Y1005N CONNECTOR mm [in]

