



LEOPARD IMAGING INC

LI-JXAV-MIPI-ADPT-6CAM-FP

Data Sheet

Technical details

- Compatible with Nvidia® Jetson AGX Xavier™ Developer Kit
- Support four 2-lane and two 4-lane MIPI cameras or six 2-lane MIPI cameras
- FPGA included to support camera sync (camera sync also relies on the camera board with trigger/slave mode)
- Camera interface part#: 20525-030E-02C
- Support I-PEX cable: FAW-1233-xx
- Part#: **LI-JXAV-MIPI-ADPT-6CAM-FP**

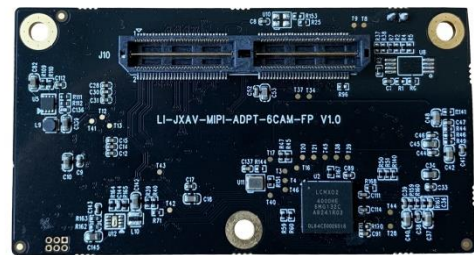

BOM

#	Items	QTY
1	LI-JXAV-MIPI-ADPT-6CAM-FP	1
2	DC 5V power supply	1



Dimensions

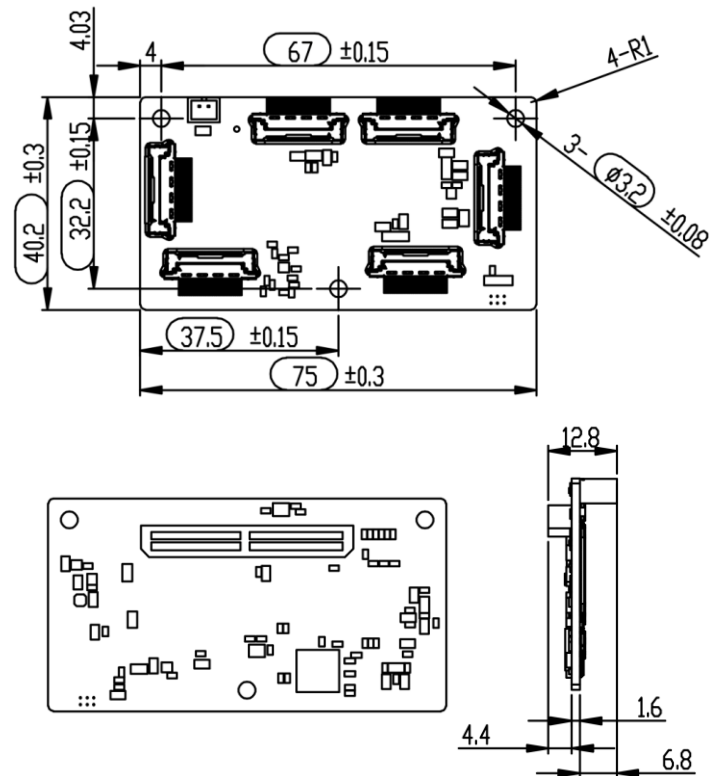

Leopard Imaging Inc.

48820 Kato Rd, Suite 100B, Fremont, CA 94538, USA
 Phone: +1-408-263-0988
 Fax: +1-408-217-1960
 Email: sales@leopardimaging.com
 Website: www.leopardimaging.com

Interfaces

Interface J1 (camera channel 1)

- Part#: 20525-030E-02C
- Number of Positions: 30
- Pitch: 0.4mm
- Mating I-PEX cable: FAW-1233-xx

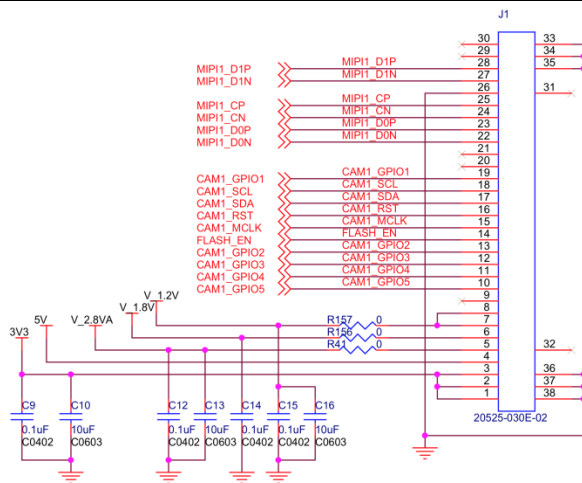

Interface J2 (camera channel 2)

- Part#: 20525-030E-02C
- Number of Positions: 30
- Pitch: 0.4mm
- Mating I-PEX cable: FAW-1233-xx

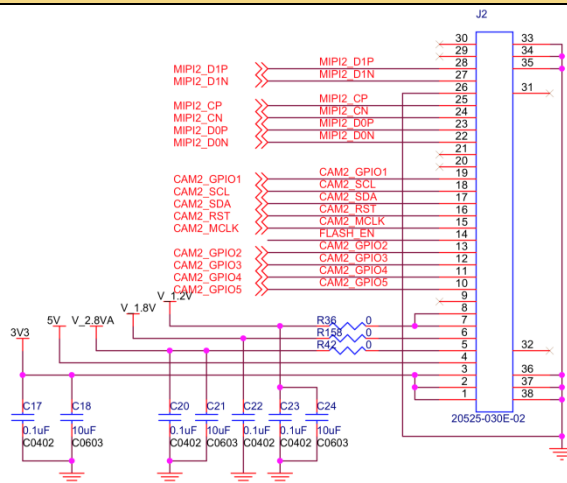

Interface J3 (camera channel 3)

- Part#: 20525-030E-02C
- Number of Positions: 30
- Pitch: 0.4mm
- Mating I-PEX cable: FAW-1233-xx

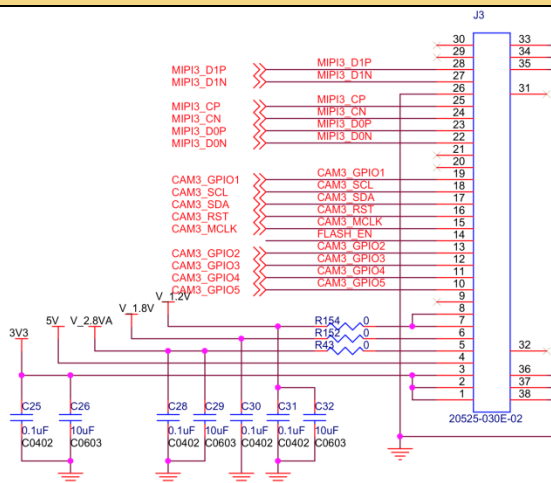

Leopard Imaging Inc.

48820 Kato Rd, Suite 100B, Fremont, CA 94538, USA
 Phone: +1-408-263-0988
 Fax: +1-408-217-1960
 Email: sales@leopardimaging.com
 Website: www.leopardimaging.com

Interface J4 (camera channel 4)

- Part#: 20525-030E-02C
- Number of Positions: 30
- Pitch: 0.4mm
- Mating I-PEX cable: FAW-1233-xx

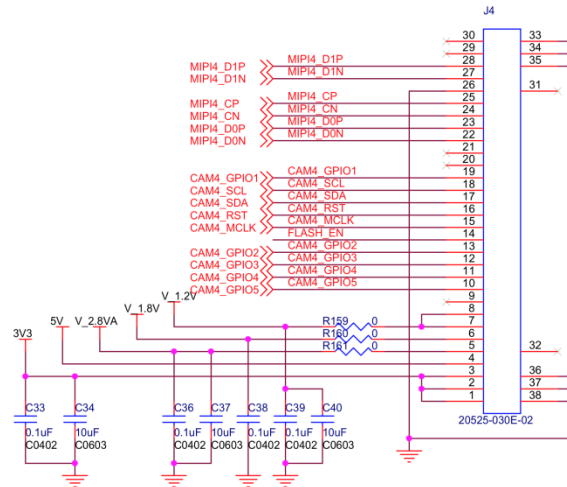

Interface J5 (camera channel 5)

- Part#: 20525-030E-02C
- Number of Positions: 30
- Pitch: 0.4mm
- Mating I-PEX cable: FAW-1233-xx

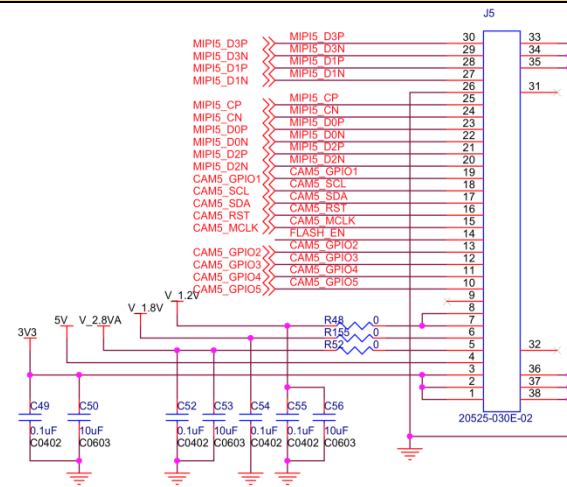

Interface J6 (camera channel 6)

- Part#: 20525-030E-02C
- Number of Positions: 30
- Pitch: 0.4mm
- Mating I-PEX cable: FAW-1233-xx

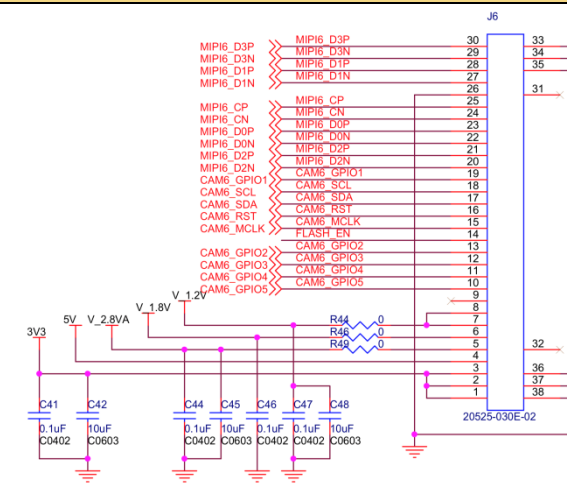

Leopard Imaging Inc.

48820 Kato Rd, Suite 100B, Fremont, CA 94538, USA
 Phone: +1-408-263-0988
 Fax: +1-408-217-1960
 Email: sales@leopardimaging.com
 Website: www.leopardimaging.com

Interface J16 (FPGA programming interface)

- Part#: 20021311-00006T4LF
- Number of Positions: 6
- Pitch: 0.050" (1.27mm)
- Number of Rows: 2

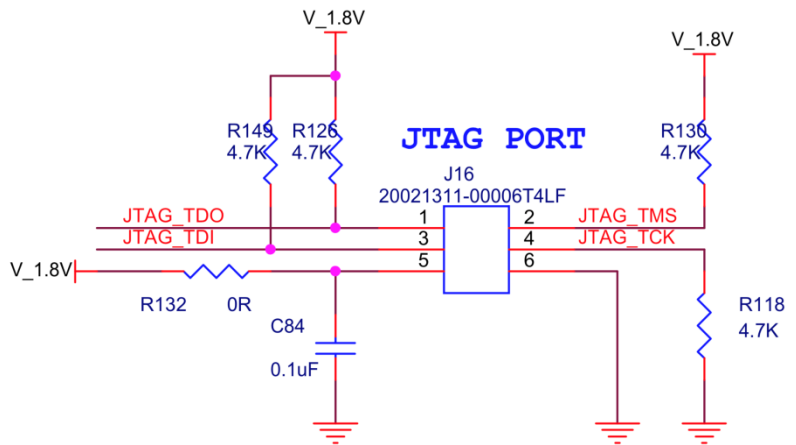

Interface J15 (External power input interface)

- Part#: 0894000220
- Number of Positions: 2
- Pitch: 2 mm

External Input Power

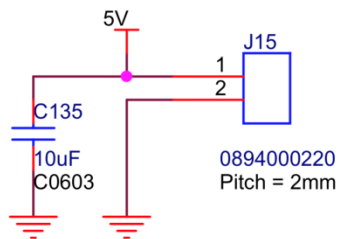

Leopard Imaging Inc.

48820 Kato Rd, Suite 100B, Fremont, CA 94538, USA
 Phone: +1-408-263-0988
 Fax: +1-408-217-1960
 Email: sales@leopardimaging.com
 Website: www.leopardimaging.com

Interface J10 (To Xavier)

- Part#: QTH-060-01-L-D-A
- Number of Positions: 120
- Number of Rows: 2
- Pitch: 0.5 mm

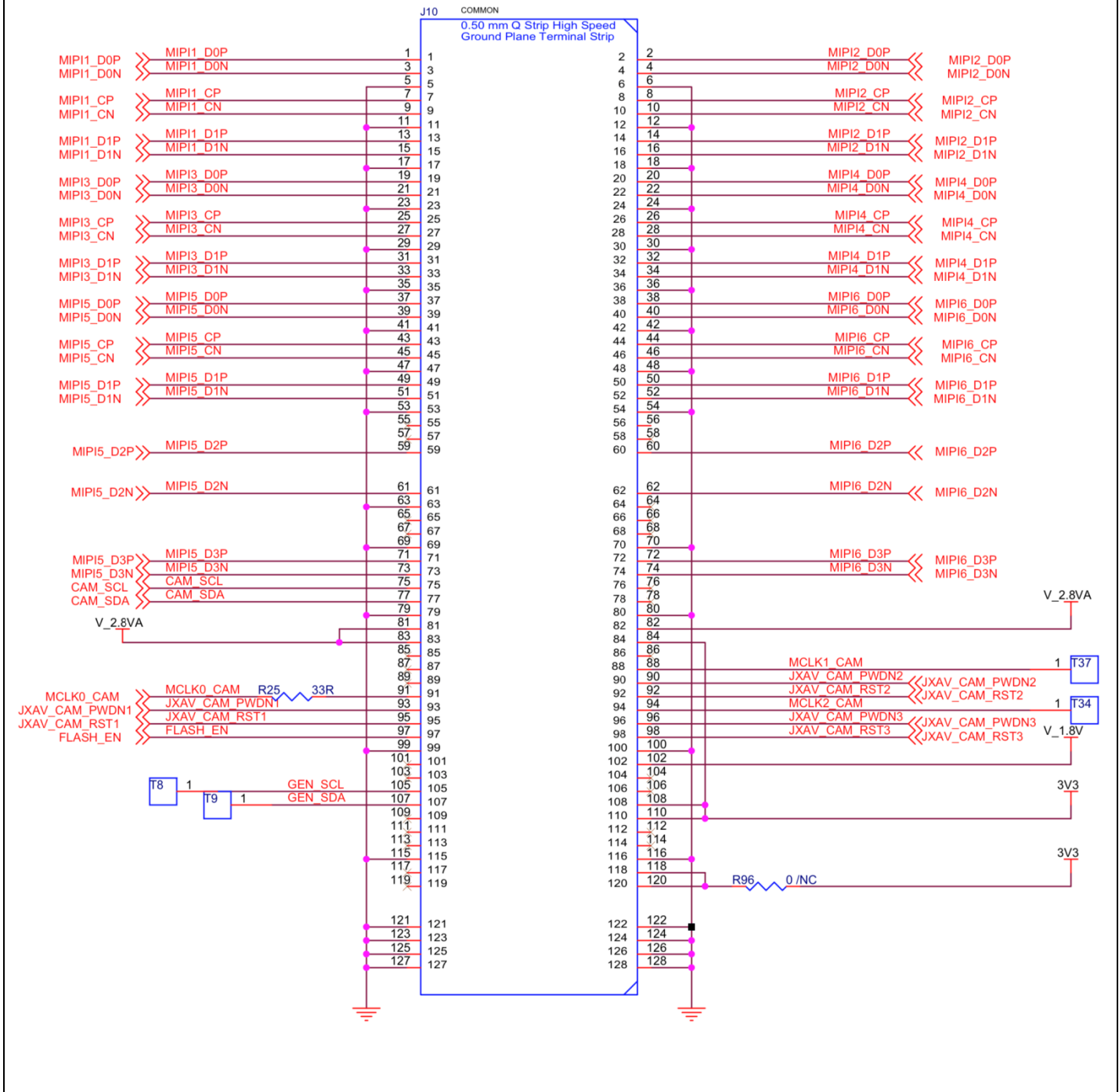

Leopard Imaging Inc.

48820 Kato Rd, Suite 100B, Fremont, CA 94538, USA
 Phone: +1-408-263-0988
 Fax: +1-408-217-1960
 Email: sales@leopardimaging.com
 Website: www.leopardimaging.com