



LIC01 Series

Application Specific Discretetes
A.S.D.™

LIGHT IGNITION CIRCUIT

FEATURES

- HIGH VOLTAGE BREAKOVER DIODE:
 $V_{BO \text{ MIN}} = 195 \text{ or } 215 \text{ V}$
- HIGH HOLDING CURRENT STRUCTURE :
 $I_H > 50 \text{ mA}$
- HIGH PEAK CURRENT PULSE CAPABILITY :
 $I_{TRM} = 50 \text{ A}$
- DIRECT OPERATION ON 220/240 VAC MAINS CIRCUITS

BENEFITS

- SPACE SAVING THANKS TO MONOLOTHIC FUNCTION INTEGRATION
- HIGH RELIABILITY WITH PLANAR TECHNOLOGY

DESCRIPTION

The LIC01 has been especially designed for high voltage pulse generation circuits such as light ignitors for :

- . High pressure sodium lamp
- . Lamp flashing circuit
- . Metal Halid lamp

It uses a high performance planar diffused technology device suitable for high surge current operation in rugged environmental conditions.

When the voltage across the device reaches the breakover voltage, it decreases from an off-state to low voltage on-state condition. When the current through the circuit drops below the holding current I_H , the device comes back to the off-state.

DEVICE TYPE	BREAKDOWN VOLTAGE RANGE
LIC01-195	$V_{BO \text{ min}}: 195\text{V}$ $V_{BO \text{ max}}: 230\text{V}$
LIC01-215	$V_{BO \text{ min}}: 215\text{V}$ $V_{BO \text{ max}}: 255\text{V}$

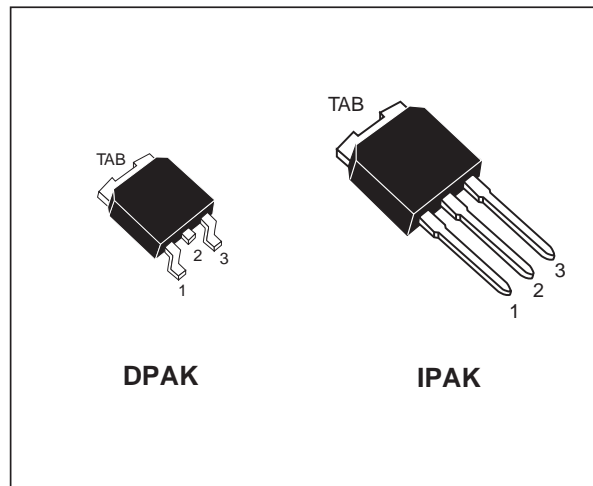

FUNCTIONAL DIAGRAM

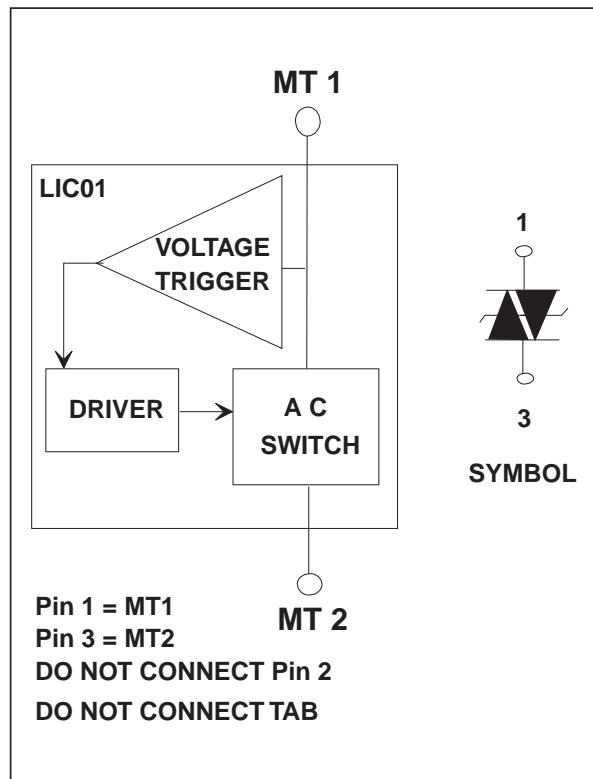

LIC01 Series

ABSOLUTE RATINGS (limiting values)

Symbol	Parameter		Value	Unit
I_{TRM}	Repetitive surge peak on state current	$t_p = 10\mu s$ (note 1)	± 50	A
$I_{T(RMS)}$	RMS on state current	$T_{amb} = 90^\circ C$	1.2	A
di/dt	Critical rate of rise on state current		80	A/ μs
V_{DRM} / V_{RRM}	Repetitive peak off state voltage	$T_j = 125^\circ C$	180	V
T_{stg}	Storage junction temperature range		- 40 to + 125	$^\circ C$
T_j	Operating junction temperature range		-20 to 125	$^\circ C$
T_L	Maximum lead temperature for soldering during 10s		260	$^\circ C$

Note 1 : Test current waveform

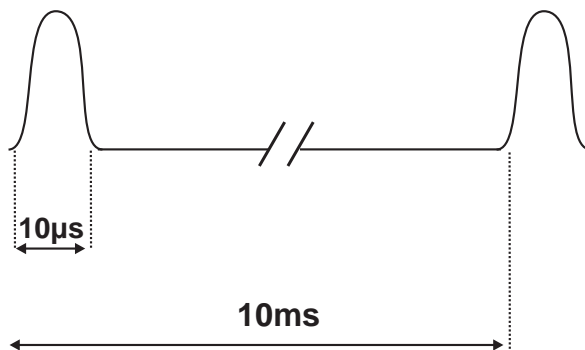

THERMAL RESISTANCE

Symbol	Parameter	Value	Unit
$R_{th(j-a)}$	Junction to ambient	100	$^\circ C/W$
$R_{th(j-c)}$	Junction to case	3.5	$^\circ C/W$

ORDERING INFORMATION

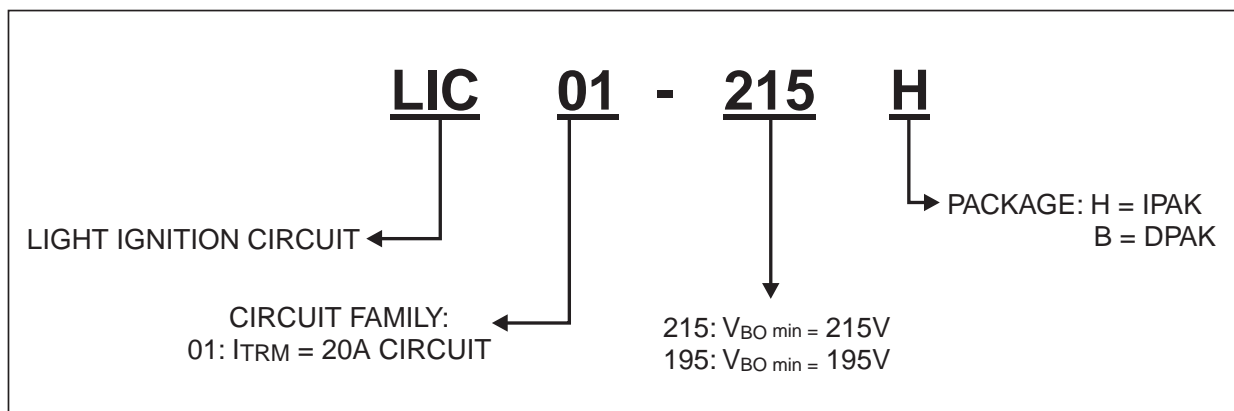

ELECTRICAL CHARACTERISTICS

Symbol	Parameters
V_{RM}	Stand-off voltage
V_{TM}	On-state voltage
V_{BO}	Breakover voltage
I_{TM}	On-state current
I_H	Holding current
I_{BO}	Breakover current
I_{RM}	Leakage current

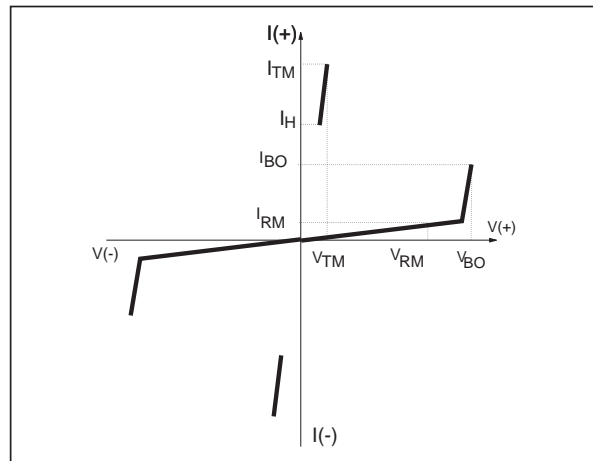

ELECTRICAL PARAMETERS

Symbol	Test conditions		Value	Unit		
I_{RM}	$V_D = V_{RM} 180V$	$T_j = 25^\circ C$	MAX	5	μA	
		$T_j = 125^\circ C$	MAX	50	μA	
V_{BO}	I_{BO}	LIC01-195	$T_j = 25^\circ C$	MIN	195	V
			MAX	230		
		LIC01-215	$T_j = 25^\circ C$	MIN	215	V
			MAX	255		
I_{BO}	$V_{BO} \text{ max.}$	$T_j = 25^\circ C$	TYP	200	μA	
			MAX	500		
I_H	$I_T = 350mA$	$T_j = 25^\circ C$	MIN	50	mA	
V_{TM}	$I_{TM} = 1A$	$T_j = 25^\circ C$	MAX	5	V	

HOLDING CURRENT TEST CIRCUIT

$R1 = 1k\Omega / 50W$ (a 220V / 60W bulb can be used)

$R2 = 22\Omega$
 $C2 = 220nF$ } Auxiliary network providing the complete firing of the LIC01 under test

LIC01 Series

VARIATION OF V_{BO} VERSUS JUNCTION TEMPERATURE

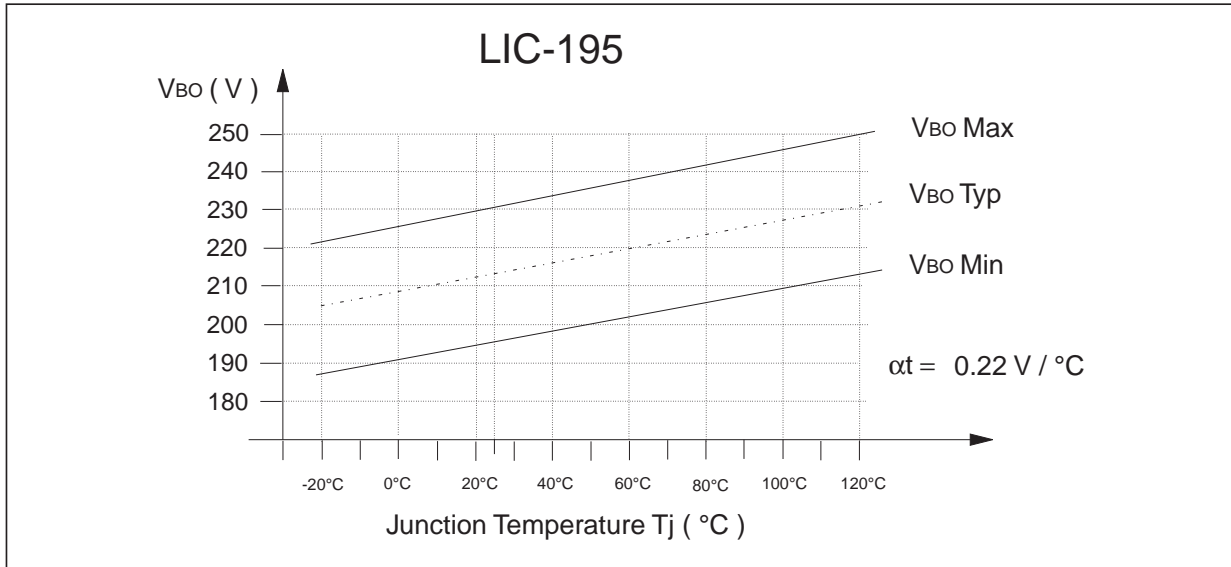

VARIATION OF V_{BO} VERSUS JUNCTION TEMPERATURE

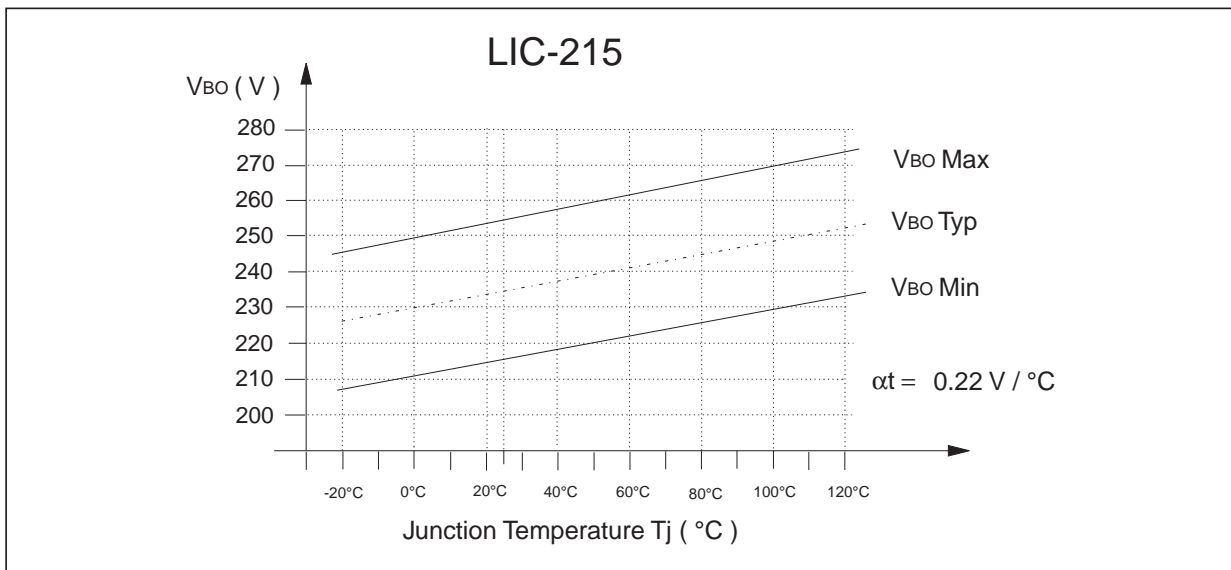

TYPICAL APPLICATION

When the peak voltage across C1 reaches the break over voltage V_{BO} of the LIC01, this device turns on and produces a pulse of current through the primary of the transformer. In turn, the transformer generates high voltage pulses across the lamp.

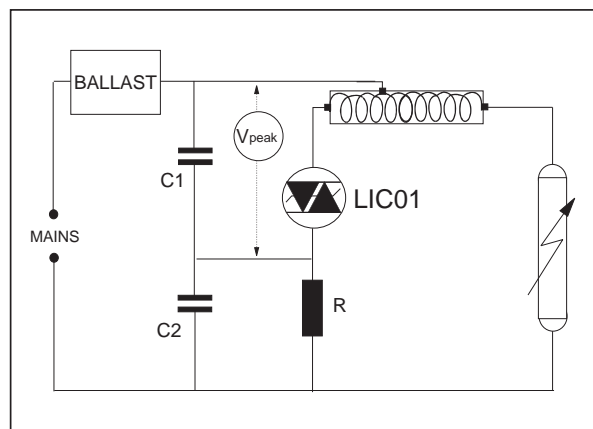

PACKAGE MECHANICAL DATA
DPAK (Plastic)

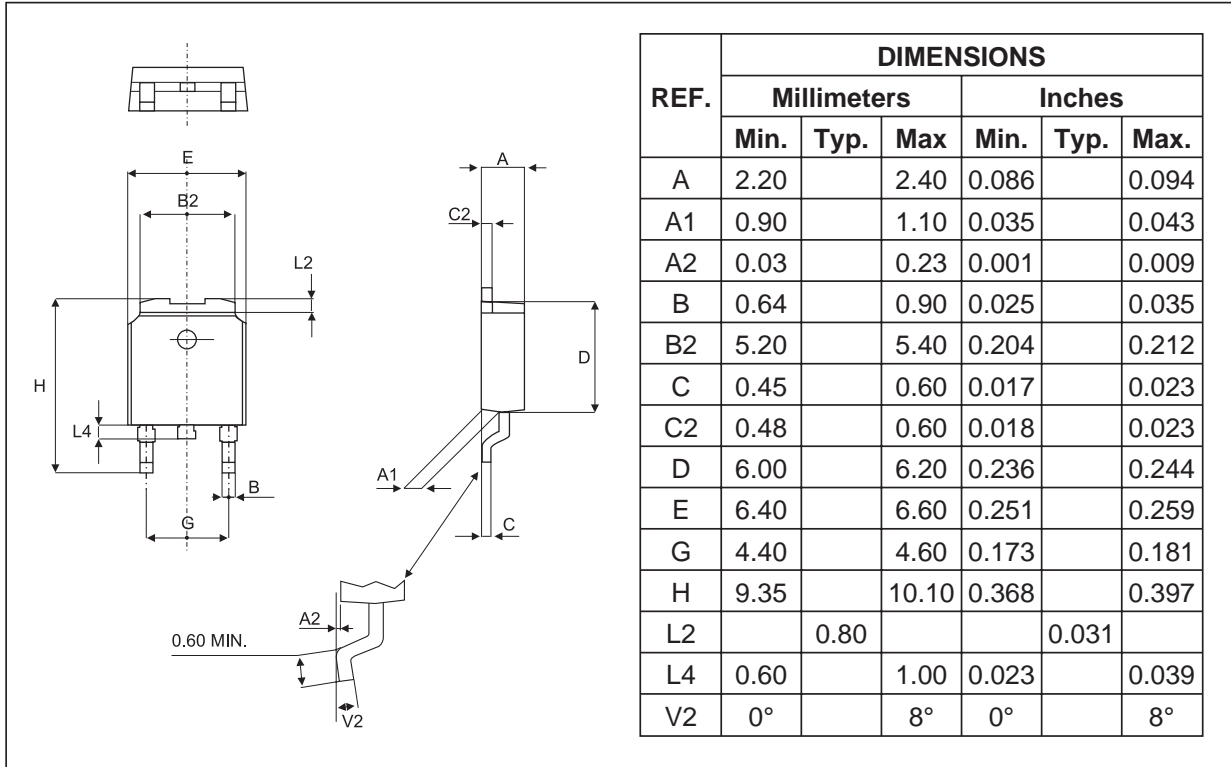

FOOT PRINT DIMENSIONS (in millimeters)

