

Data Sheet

LL01CR-NExxL06-M2



Xlamp XP-E



■ Features & Typical Applications

- High efficiency
- Available with 8 beam angles
- Optimized Uniformity
- Lens with Holder
- Architectural Lighting
- Commercial Lighting

■ Table of Contents

General Information & Product Nomenclature.....	P.2
Optical Specifications	P.3
Mechanical Specifications	P.6
Package Specifications.....	P.7

LL01CR-NExxL06-M2

General Information

- Lens Material : PMMA
- Operating Temperature range -40°C~+70°C(upper limit +80°C).
- Storage Temperature range -40°C~+70°C(upper limit +80°C).
 - * Average transmittance in visible spectrum 400nm~700nm>90%.
(For raw material only)
- Usage and Maintenance:
 1. If necessary, clean lenses with mild soap, water and soft cloth.
 2. Never use any commercial cleaning solvents on lenses, like alcohol.
 3. Please handle or install lenses with wearing gloves, skin oils may damage lens or its optical characteristic.

Product Nomenclature

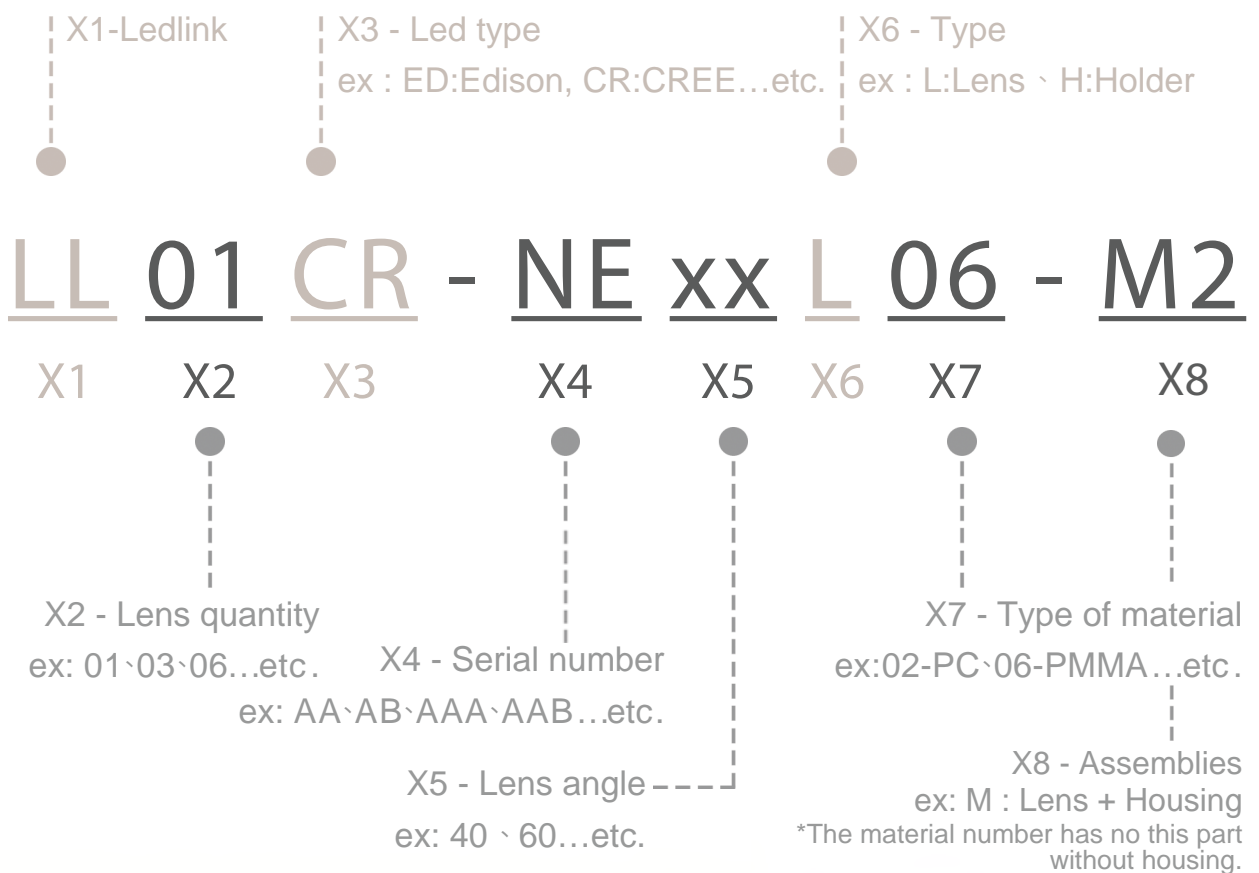

LL01CR-NExxL06-M2 Optical Specifications

Xlamp XP-E

Note: (1) All the results of analysis are based on 0 degrees of elevation.
 (2) Tolerance: $\pm 10\%$.
 (3) Led Luminous Flux(lm): $100 \pm 5\%$.

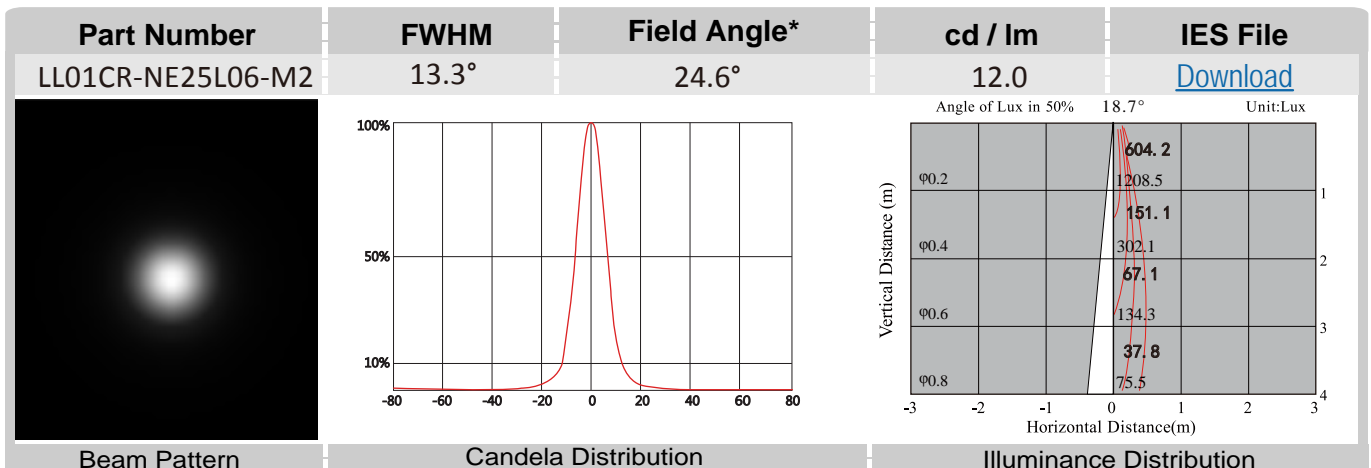
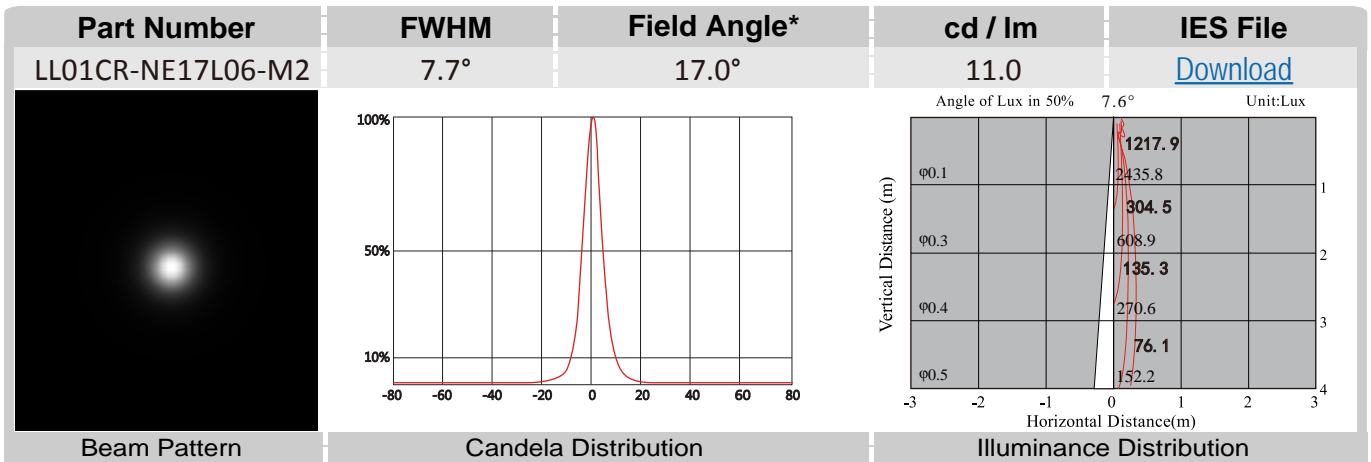
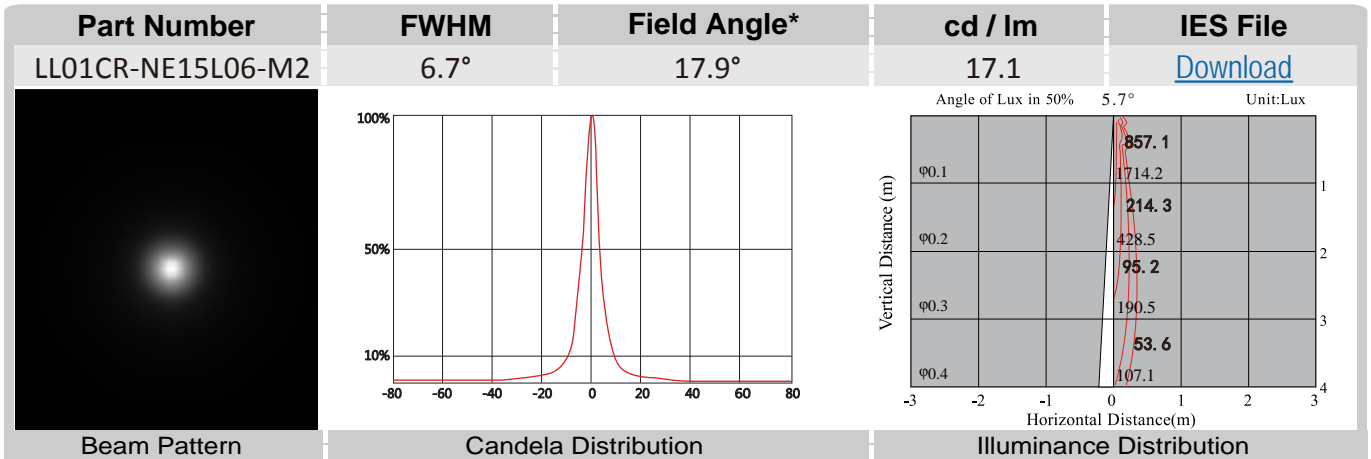

LL01CR-NExxL06-M2 Optical Specifications

Xlamp XP-E

Note: (1) All the results of analysis are based on 0 degrees of elevation.
 (2) Tolerance: $\pm 10\%$.
 (3) Led Luminous Flux(lm):100($\pm 5\%$).

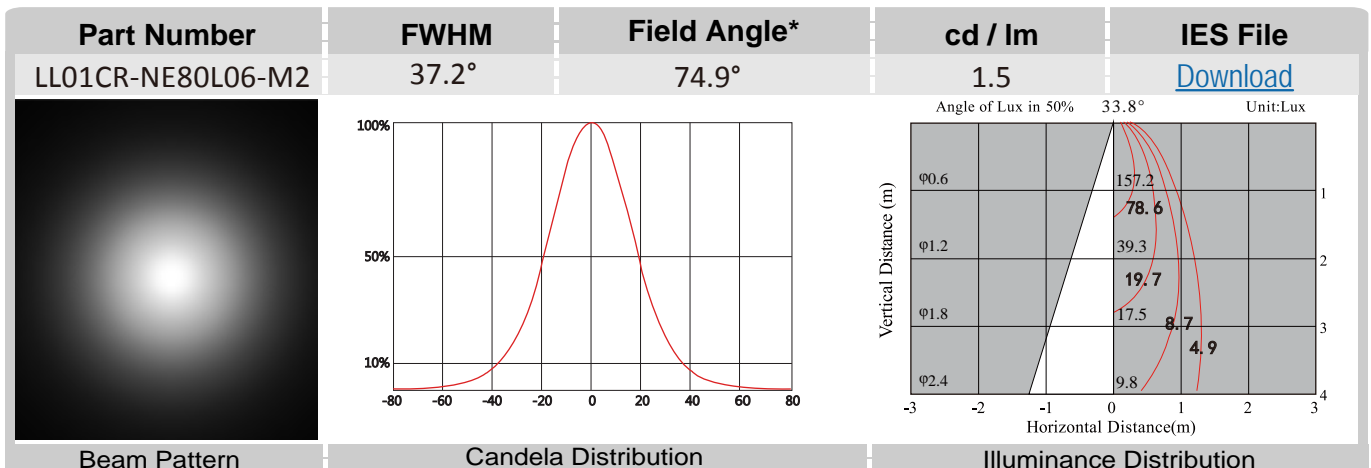
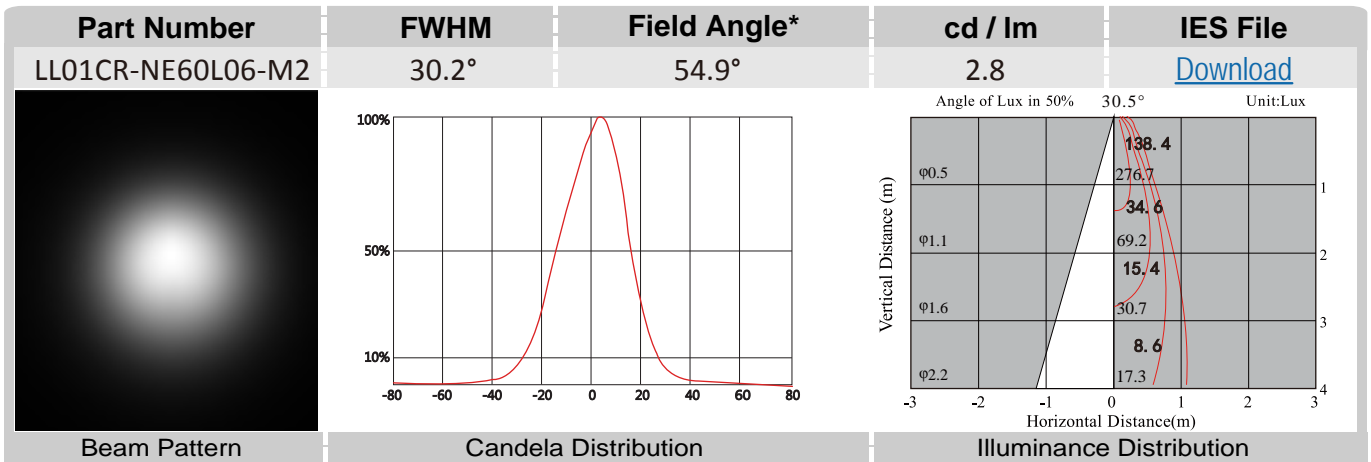
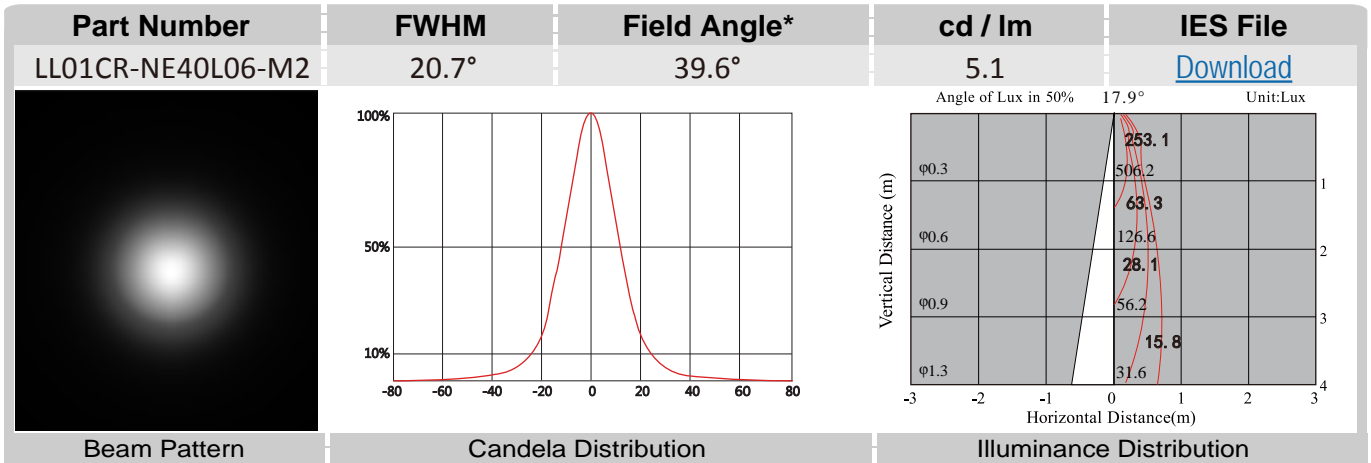

LL01CR-NExxL06-M2 Optical Specifications

Note: (1) All the results of analysis are based on 0 degrees of elevation.
 (2) Tolerance: $\pm 10\%$.
 (3) Led Luminous Flux(lm):100($\pm 5\%$).



Xlamp XP-E

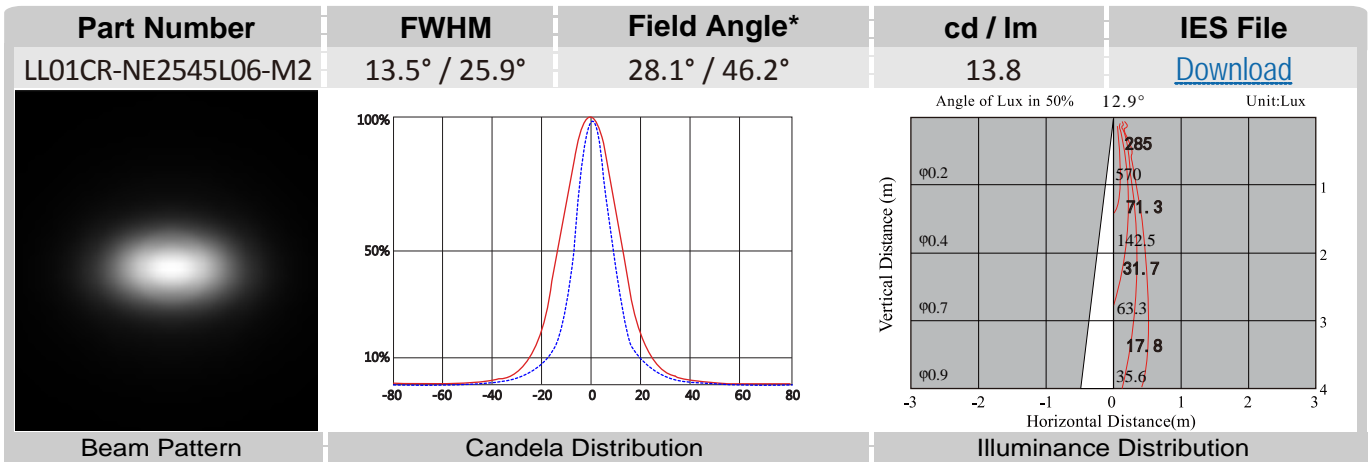
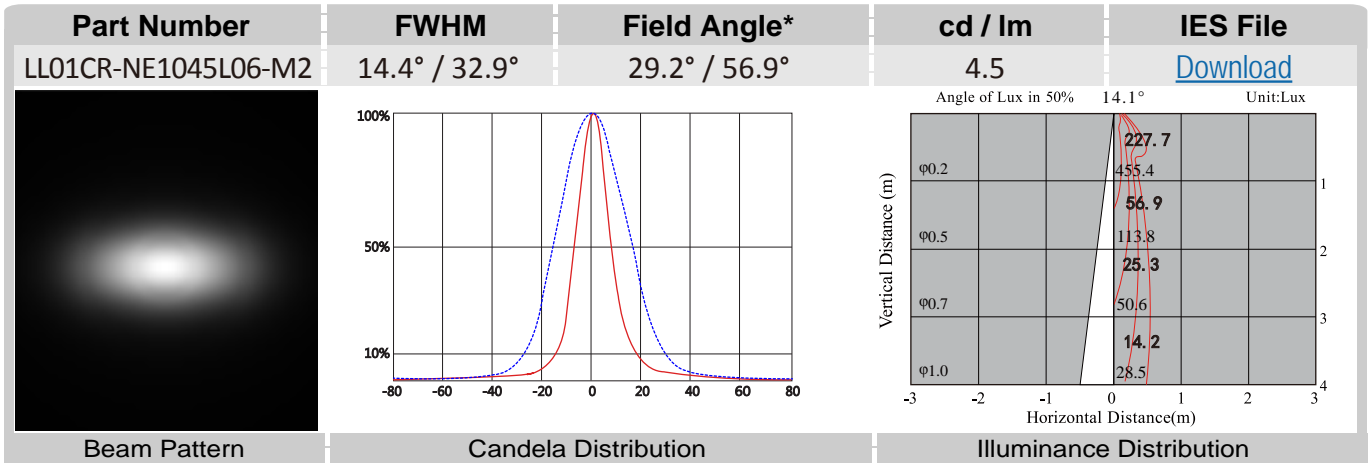

LL01CR-NE_xxL06-M2 Mechanical Specification

1. Fixing method

Glue
 Screw
 Tape
 Fixing-ring
 Frame

Note: (1) All dimensions are in mm.

2. Lens dimension

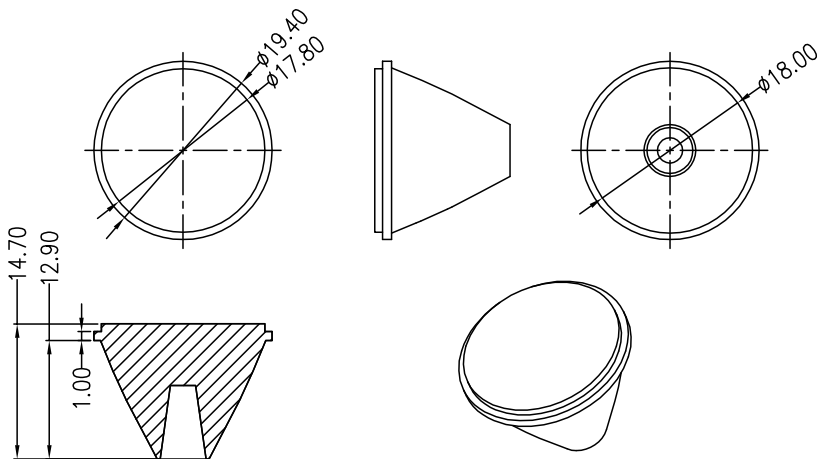

3. Assembly instruction



4. Lens assembly dimensions

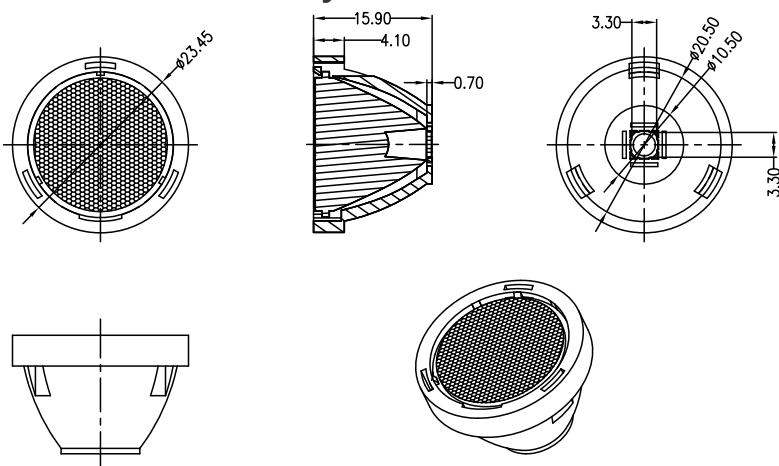

5. View assembly lens with LED:

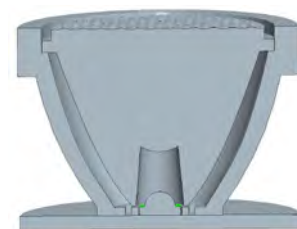

Holder part number : LL01CRKI25H2