

DATA SHEET

Liquid Level Switches

Optomax Digital Series



FEATURES

- Liquid level switches that can detect almost any liquid type; oil or water based
- Choice of material; Polysulfone (standard) or Trogamid®
- Choice of threads

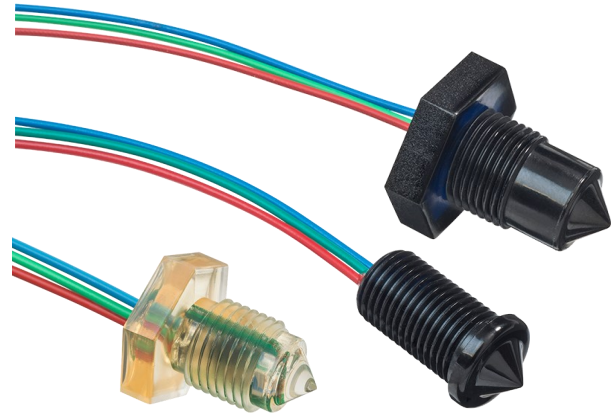

Housing/ Mounting <ul style="list-style-type: none">M10x1M12x11/4" NPT1/2"-20 UNF	Output Type / Logic <ul style="list-style-type: none">PUSH PULLHIGH IN AIR (1/0)LOW IN AIR (0/1)PWM	Supply Voltage <ul style="list-style-type: none">4.5 - 15.4 V VOLTAGE	Output Current <ul style="list-style-type: none">UP TO 100mA CURRENT	Temp <ul style="list-style-type: none">-25°C to +80°C TEMPERATURE-40°C to +125°C TEMPERATURE
---	---	--	---	--

BENEFITS

- Low power
- Low cost
- Compact design

TECHNICAL SPECIFICATIONS

Supply voltage (Vs)	4.5V _{DC} to 15.4V _{DC}
or	4.5V _{DC} to 5.5V _{DC} (PWM output)
Supply current (Is)	2.5mA max. (Vs = 15.4V _{DC})
Output sink and source current (Iout)	100mA
Operating temperatures	Standard: -25°C to +80°C Extended: -40°C to +125°C
Storage temperatures	Standard: -30°C to +85°C Extended: -40°C to +125°C
Housing material ^a	Polysulfone or Trogamid [®]
Sensor termination	24AWG, 250mm PVDF wires, 10mm tinned

OUTPUT VALUES

Output Voltage (Vout):	Iout = 100mA
Output High	Vout = Vs - 1.5V max
Output Low	Vout = 0V + 0.5V max

PWM	
Duty cycle in air	25% ± 10%
Duty cycle in liquid	75% ± 10%
Frequency	2kHz ± 10%

Other sensor options available on request, email: technical@sstsensing.com

Need help? Ask the expert
Tel: + 44 (0)1236 459 020
and ask for "Technical"



NOTES

- Before use check that the fluid in which you wish to use these devices is compatible either with Polysulfone or Trogamid[®]. Some common fluids and compatibility can be found in SST's [Liquid Level Switches – Installation, Operation and Compatibility Guide \(AN 0041\)](#).
- When using Trogamid[®] above +85°C some oil based liquids can cause deformation of the sensing tip, and must be tested for compatibility.

OUTLINE DRAWING

All dimensions shown in mm. Tolerances = $\pm 1\text{mm}$.

Type 1

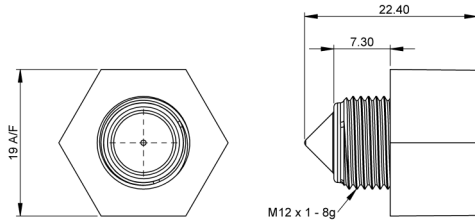

Type 2

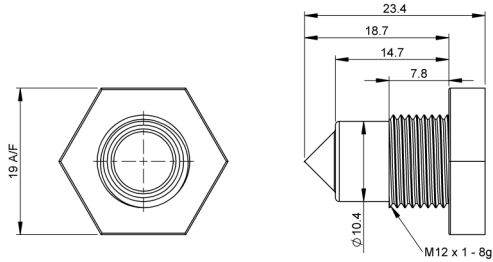

Type 3

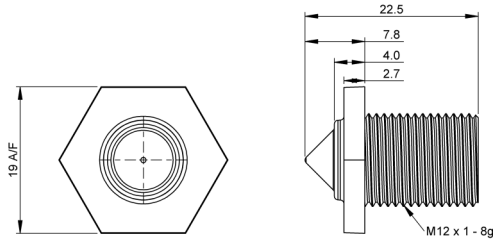

Type 5

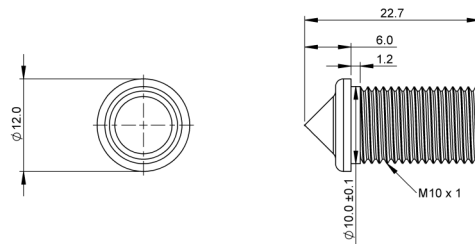

Type 6

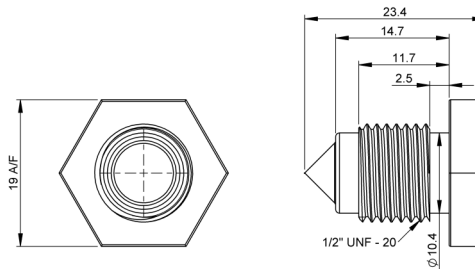

Type 7

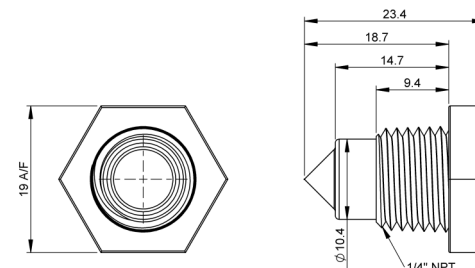

HOUSING SPECIFICATIONS

Installation drawings and 3D (.step) files available on [the product webpage](#).

	Housing Series		
	Type 1	Type 2	Type 3
Thread	M12x1-8g		
Pressure ^d	7 bar / 101 psi maximum		
Tightening Torque	1.5 Nm / 13.26 in-lbs maximum		

	Housing Series		
	Type 5	Type 6	Type 7
Thread	M10x1	1/2"-20 UNF	1/4" NPT
Pressure ^d	20 bar / 209 psi max.	7 bar / 101 psi maximum	
Tightening Torque	1.5 Nm / 13.26 in-lbs maximum		

ELECTRICAL INTERFACE

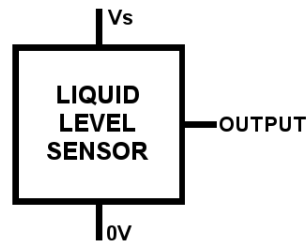

Wire	Designation
Red	Vs
Green	Output
Blue	0V



- c) Recommended nuts and sealing accessories outlined within the [Accessory Table](#)
 d) When correctly sealed.

In order to suit any application, these sensors have been designed with various output circuit configurations.

Digital Output High in Air

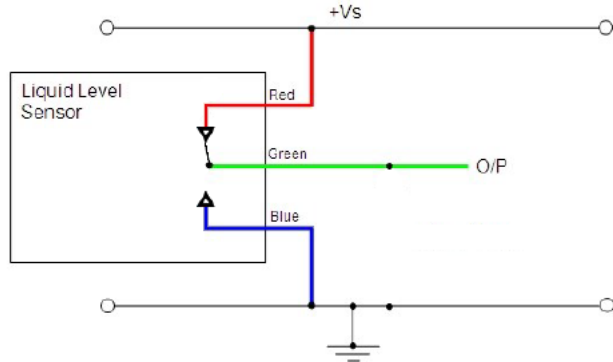

Digital Output Low in Air

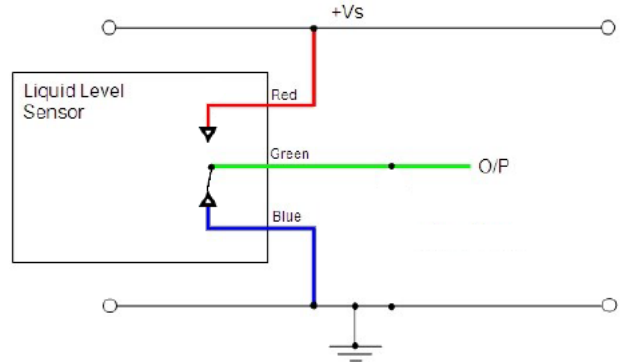

! CAUTION: Take care when connecting loads. The minimum load impedance should not exceed $V_s/\text{max output current}$.
Note: Shorting the output to V_s or $0V$ will result in irreparable damage to the sensor.

 **ORDER INFORMATION**

Generate your specific part number using the convention shown opposite. Use only those letters and numbers that correspond to the sensor and output options you require — omit those you do not require.

Sensor mounted from inside vessel

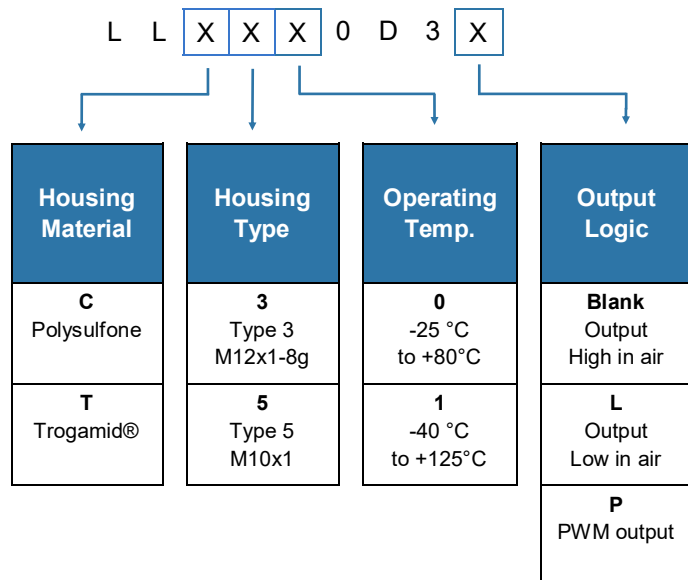

Sensor mounted from outside vessel

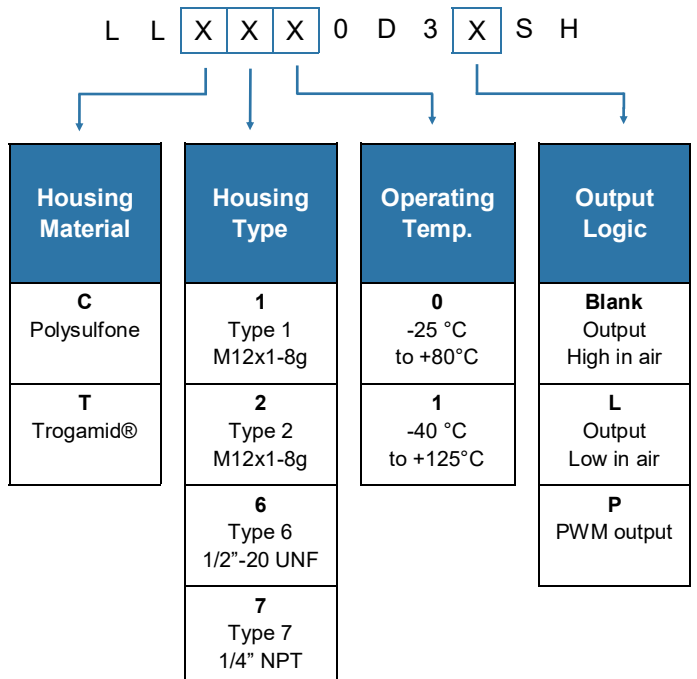

Notes:

- Type 3 and Type 5 sensors are mounted internally.
- Types 1, 2, 6 & 7 sensors are mounted externally.

Please contact SST Sensing for details; email: technical@sstsensing.com