

Precision micropower shunt voltage reference

Datasheet - production data

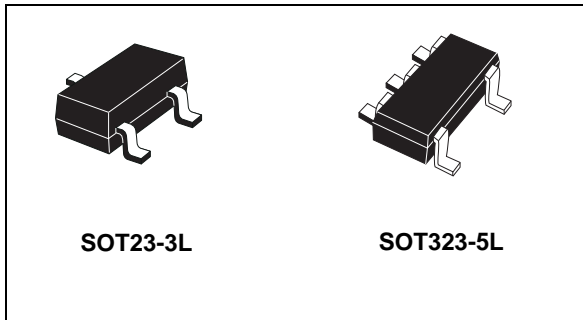

Description

The LM4041 is a micropower shunt voltage reference, providing a stable 1.225 V output voltage, with an initial accuracy of 0.1% @ 25 °C and a low temperature coefficient. Available in SOT323-5L and SOT23-3L surface mount packages, it can be designed in applications where space saving is a critical issue. The low operating current is a key advantage for power restricted designs. In addition, the LM4041 is very stable and can be used in a broad range of application conditions.

Features

- Fixed 1.225 V typical output voltage
- Ultra low operating current: 40 μ A at 25 °C
- High precision: +/- 0.1% @ 25 °C (0.2%, 0.5% and 1% versions are also available)
- Stable when used with capacitive loads
- Industrial (- 40 to+ 85 °C) and Extended (- 40 to +125 °C) temperature range versions available
- 100 ppm/°C maximum temperature coefficient
- Available in SOT23-3L and SOT323-5L packages

Applications

- Computers
- Battery chargers
- Switch mode power supply
- Battery operated equipment
- Data acquisition systems
- Energy management
- Instrumentation

Contents

1	Pin configuration	3
2	Maximum ratings	4
3	Electrical characteristics	5
4	Typical performance characteristics	6
5	Package mechanical data	8
6	Packaging mechanical data	12
7	Order codes	14
8	Revision history	15



1 Pin configuration

Figure 1. Pin connection (top view)

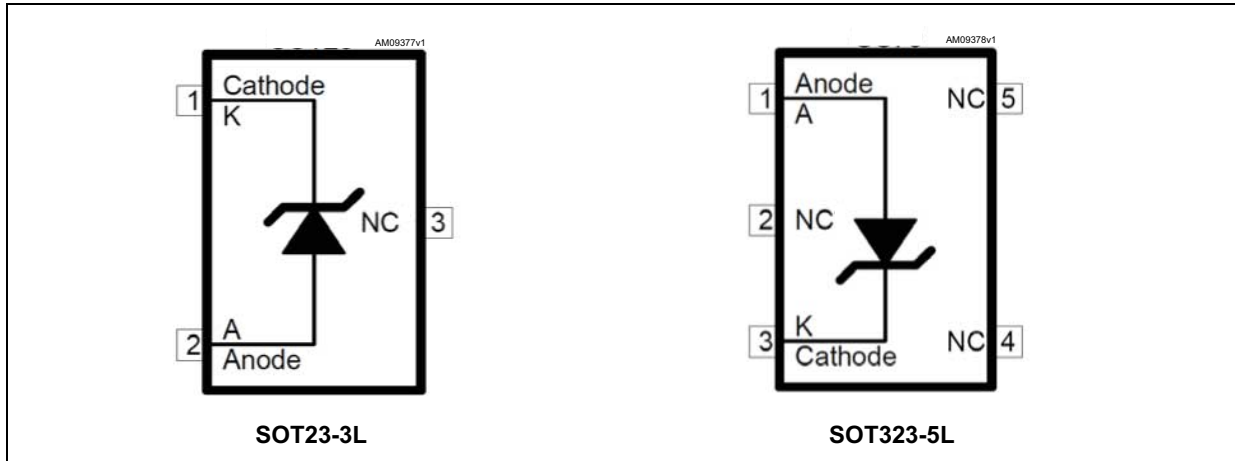

Note: Below pins must be left floating or connected to Anode pin to improve noise immunity due to PCB layout.

SOT23-3L: pin 3.

SOT323-5L: pin 2, pin 4 and pin 5.

2 Maximum ratings

Table 1. Absolute maximum ratings

Symbol	Parameter	Value	Unit
I_K	Reverse breakdown current	20	mA
V_K	Maximum cathode voltage	8	V
I_F	Forward current	10	mA
P_D	Power dissipation ⁽¹⁾		
	SOT23-3L SOT323-5L	500 536	mW
T_{STG}	Storage temperature	- 65 to +150	°C
ESD	Human body model (HBM)	2	kV
	Machine model (MM)	200	V
	Charged device model	1500	V
T_{LEAD}	Lead temperature (soldering) 10 sec	260	°C
T_J	Max junction temperature	+150	°C

1. P_D has been calculated with $T_{AMB} = 25^\circ\text{C}$ and $T_{JMAX} = 150^\circ\text{C}$.

Note: Absolute maximum ratings are those values beyond which damage to the device may occur. Functional operation under these conditions is not implied.

Table 2. Thermal data

Symbol	Parameter	SOT323-5L	SOT23-3L	Unit
R_{thJA}	Thermal resistance junction-ambient	233	248	°C/W
R_{thJC}	Thermal resistance junction-case	90	136	°C/W

Table 3. Operating conditions

Symbol	Parameter	Value	Unit
I_{KMIN}	Minimum operating current	40	μA
I_{KMAX}	Maximum operating current	12	mA
T_{OPER}	Operating free air temperature range	Industrial	- 40 to + 85
		Extended	- 40 to + 125

3 Electrical characteristics

$T_{AMB} = 25\text{ }^{\circ}\text{C}$, unless otherwise specified.

Table 4. Electrical characteristics

Symbol	Parameter	Test conditions	Min.	Typ.	Max.	Unit
V_k	Reverse breakdown voltage	$I_k = 100\text{ }\mu\text{A}$ LM4041A, 0.1% LM4041B, 0.2% LM4041C, 0.5% LM4041D, 1%	1.2238 1.2225 1.219 1.213	1.225	1.2262 1.2275 1.231 1.237	V
I_{kmin}	Minimum operating current	$T_{amb} = 25\text{ }^{\circ}\text{C}$ $-40\text{ }^{\circ}\text{C} < T_{amb} < T_{max}^{(1)}$		25	40 50	μA
$\Delta V_k/\Delta T$	Average temperature coefficient ⁽²⁾	$I_k = 100\text{ }\mu\text{A}$		± 36	± 100	ppm/ $^{\circ}\text{C}$
$\Delta V_k/\Delta I_k$	Reverse breakdown voltage change with operating current range	$I_{kmin} < I_k < 1\text{ mA}$ $-40\text{ }^{\circ}\text{C} < T_{amb} < T_{max}^{(1)}$ $1\text{ mA} < I_k < 12\text{ mA}$ $-40\text{ }^{\circ}\text{C} < T_{amb} < T_{max}^{(1)}$		0.4 4	1 8 10	mV
R_{ka}	Static impedance	$\Delta I_k = 100\text{ }\mu\text{A}$ to 1 mA		0.4	1	Ω
K_{vh}	Long term stability	$I_k = 100\text{ }\mu\text{A}$, $t = 1000\text{ hrs}$		120		ppm
e_n	Wide band noise	$I_k = 100\text{ }\mu\text{A}$, $10\text{ Hz} < f < 10\text{ kHz}$		60		μV_{RMS}

1. $T_{max} = 85\text{ }^{\circ}\text{C}$ for LM4041xI (industrial version) and $T_{max} = 125\text{ }^{\circ}\text{C}$ for LM4041xE (extended version).

2. The average temperature coefficient is defined as: $10^6 \times \{\max(\Delta V_k) / [V_{k@25^{\circ}\text{C}} \times (T_{max} - T_{min})]\}$ [ppm/ $^{\circ}\text{C}$].

Note: Limits are 100% production tested at 25 °C. Limits over temperature are guaranteed through correlation and by design.

4 Typical performance characteristics

The following plots are referred to the typical application circuit and, unless otherwise noted, at $T_A = 25\text{ }^\circ\text{C}$.

Figure 2. V_k change vs. temperature

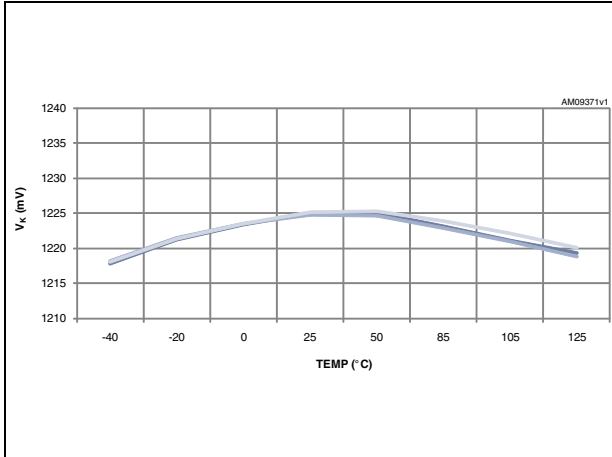

Figure 3. Minimum current for regulation

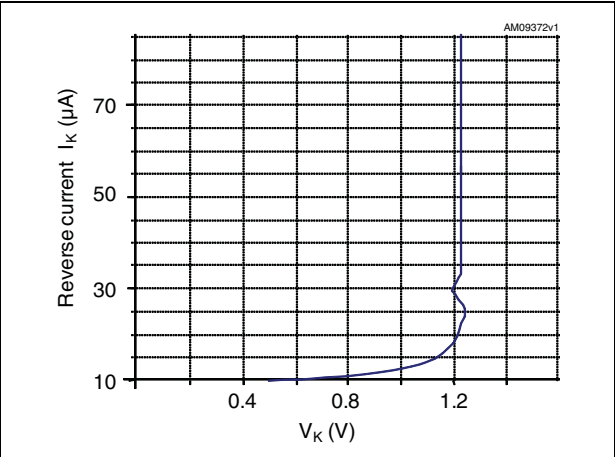

Figure 4. Output impedance vs. frequency

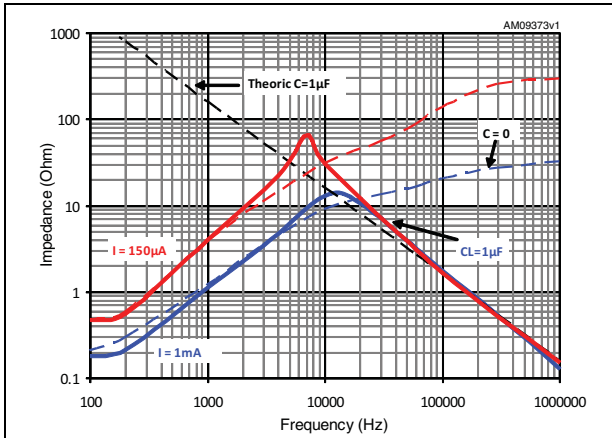

Figure 5. Minimum current for regulation vs. temperature

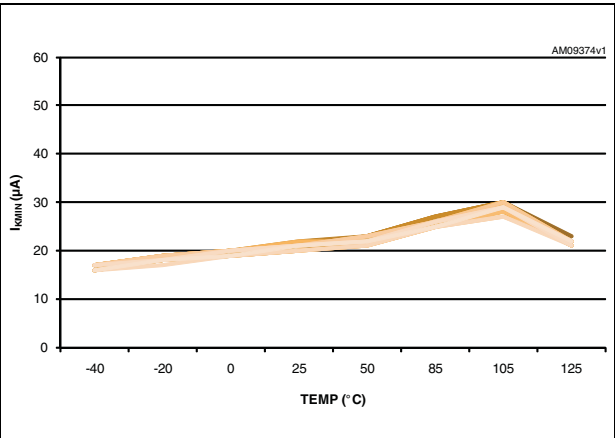

Figure 6. Startup characteristics

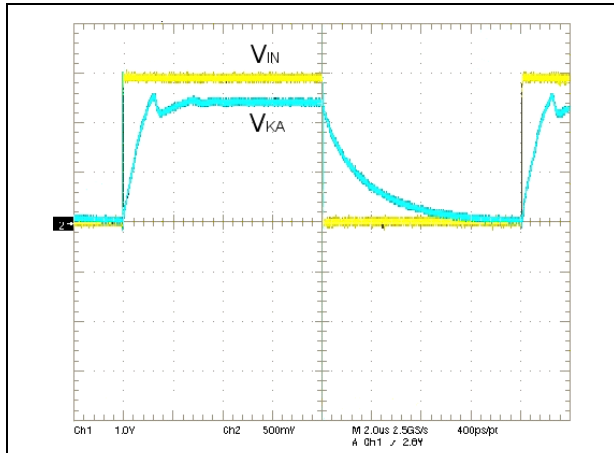

Figure 7. Startup measure circuit

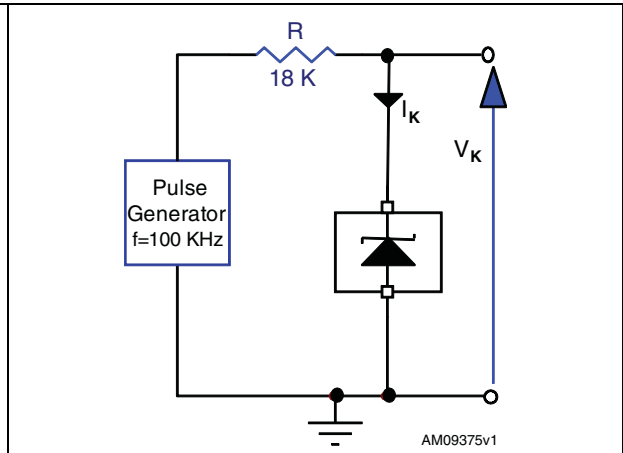
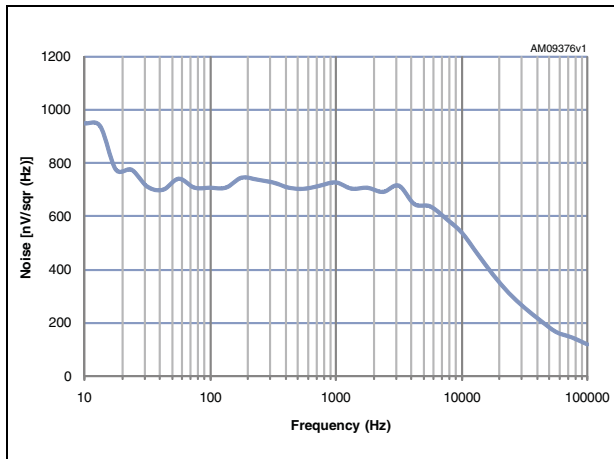

Figure 8. Wideband noise voltage



5 Package mechanical data

In order to meet environmental requirements, ST offers these devices in different grades of ECOPACK® packages, depending on their level of environmental compliance. ECOPACK specifications, grade definitions, and product status are available at: www.st.com. ECOPACK is an ST trademark.

Figure 9. SOT23-3L dimensions

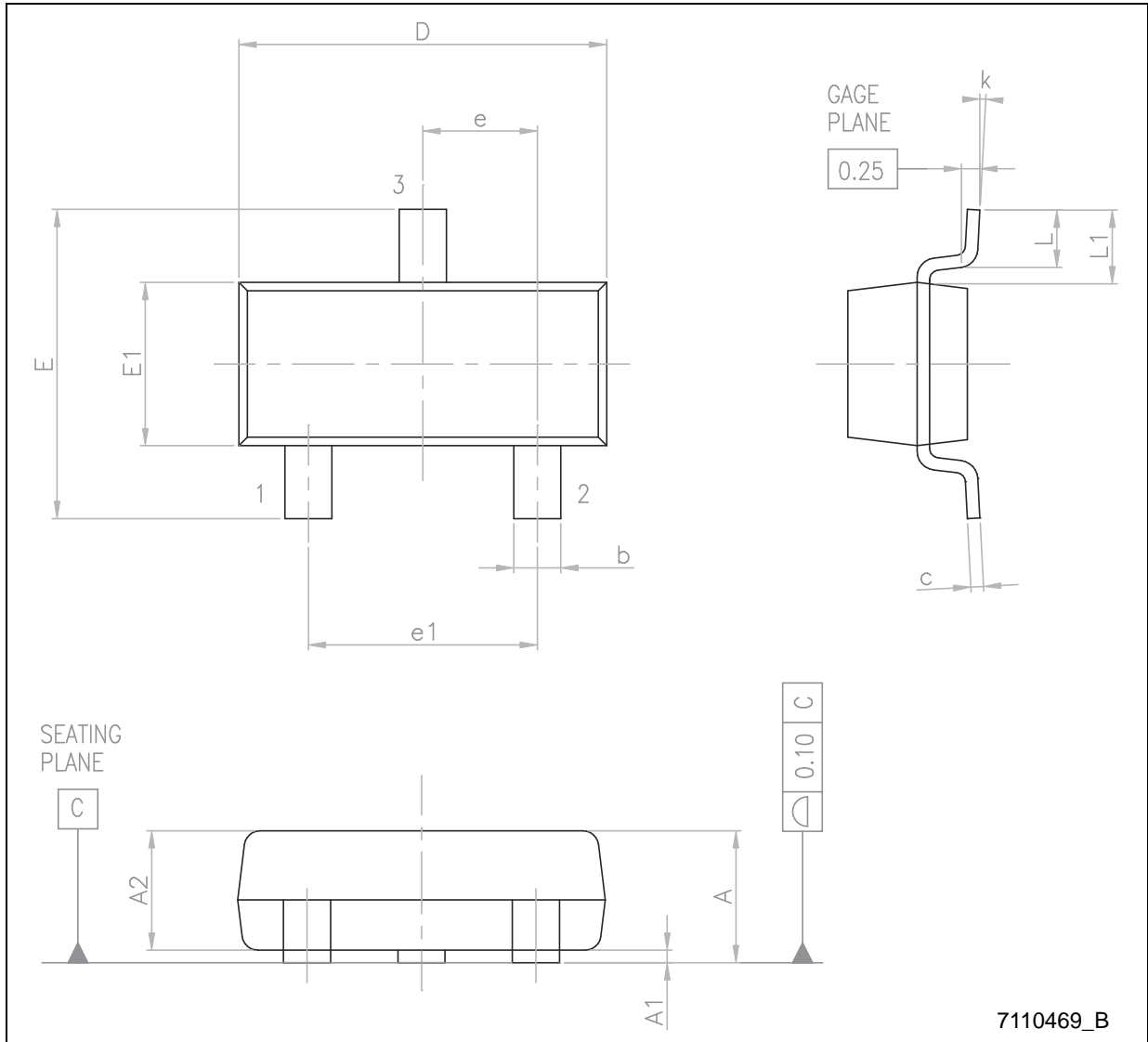

7110469_B

Table 5. SOT23-3L mechanical data

Dim.	mm.		
	Min.	Typ.	Max.
A	0.89		1.12
A1	0.01		0.10
A2	0.88	0.95	1.02
b	0.30		0.50
c	0.08		0.20
D	2.80	2.90	3.04
E	2.10		2.64
E1	1.20	1.30	1.40
e		0.95	
e1		1.90	
L	0.40	0.50	0.60
L1		0.54	
k	0°		8°

Figure 10. SOT323-5L dimensions

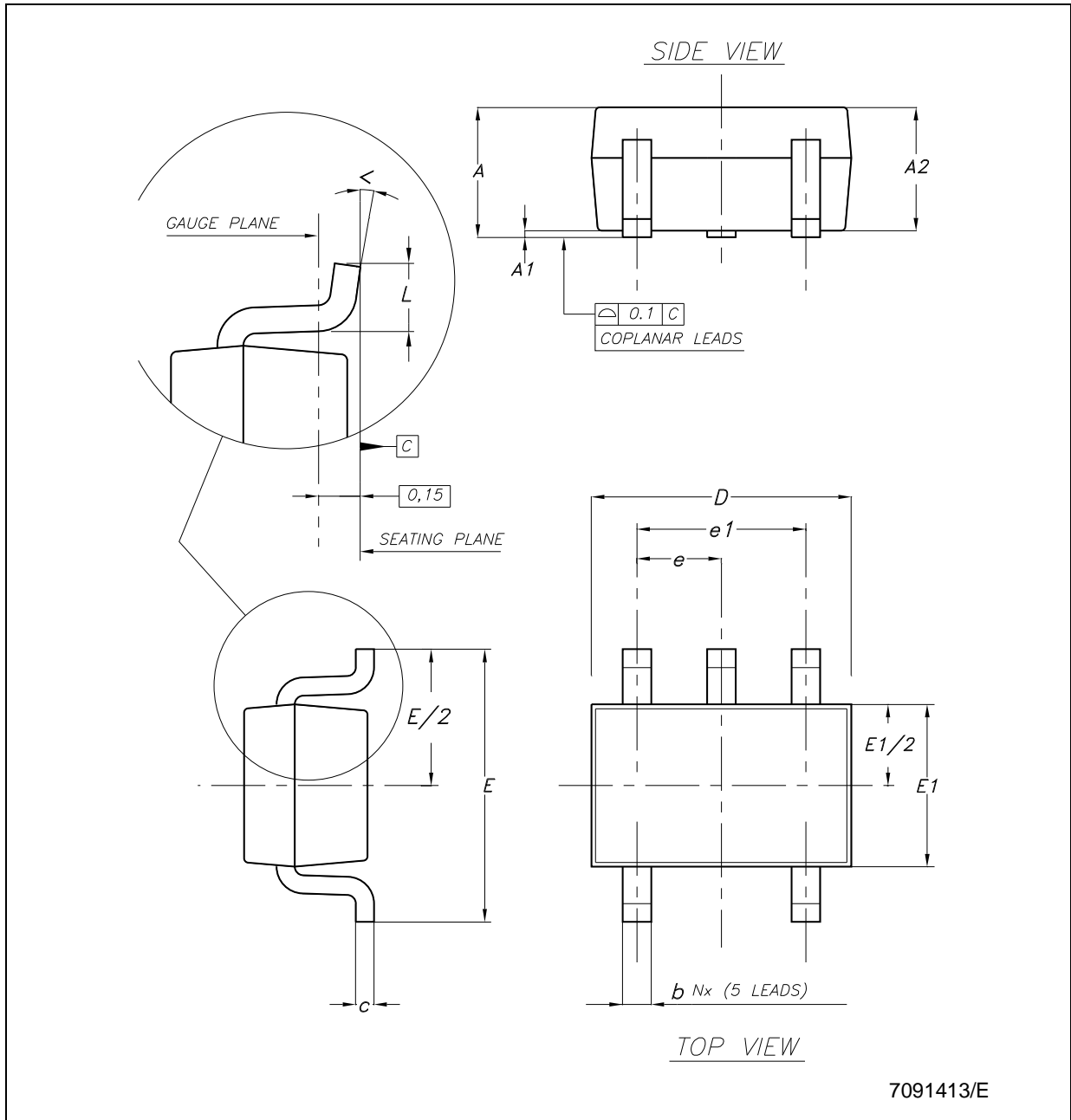

Table 6. SOT323-5L mechanical data

Dim.	mm.		
	Min.	Typ.	Max.
A	0.80		1.10
A1	0		0.10
A2	0.80	0.90	1
b	0.15		0.30
c	0.10		0.22
D	1.80	2	2.20
E	1.80	2.10	2.40
E1	1.15	1.25	1.35
e		0.65	
e1		1.30	
L	0.26	0.36	0.46
<	0°		8°

6 Packaging mechanical data

Figure 11. Tape and reel SOT23-3L and SOT323-5L mechanical drawing

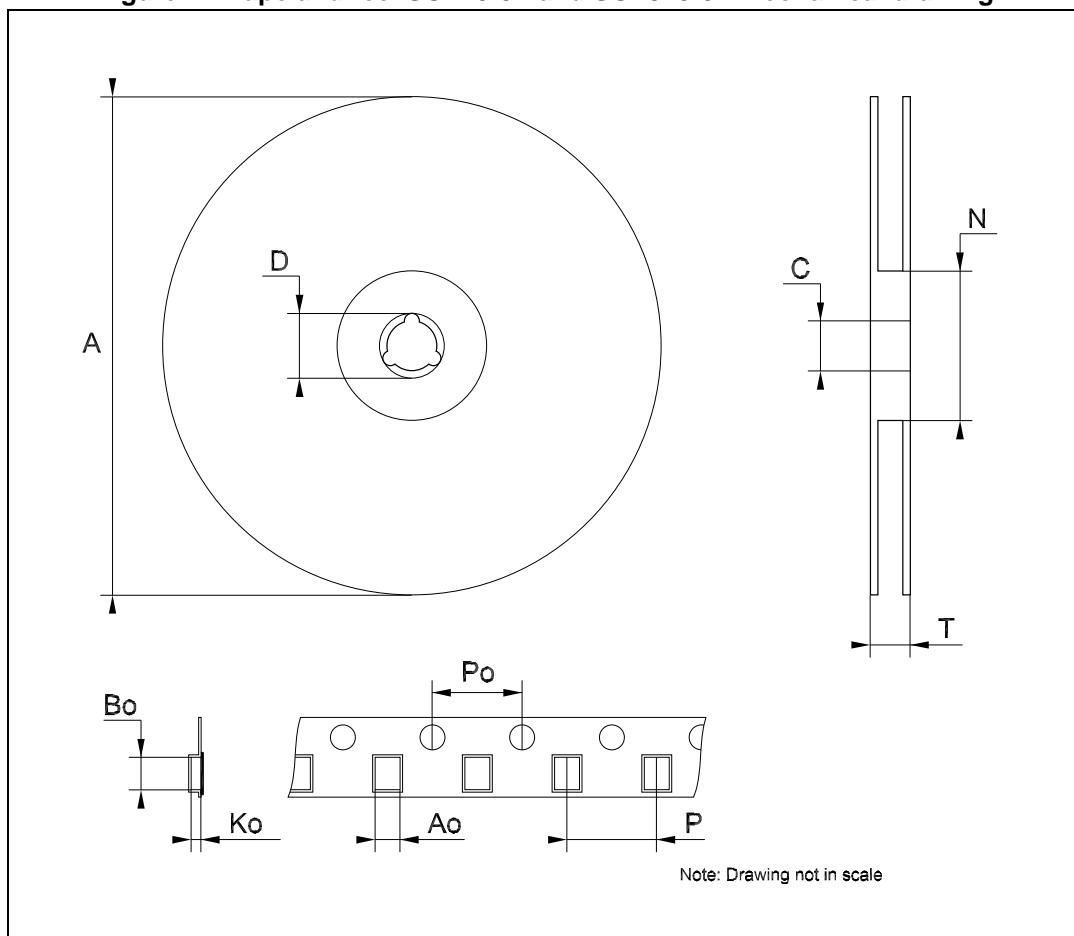

Table 7. Tape and reel SOT23-3L mechanical data

Dim.	mm		
	Min.	Typ.	Max.
A			180
C	12.8	13.0	13.2
D	20.2		
N	60		
T			14.4
Ao	3.13	3.23	3.33
Bo	3.07	3.17	3.27
Ko	1.27	1.37	1.47
Po	3.9	4.0	4.1
P	3.9	4.0	4.1

Table 8. SOT323-5L mechanical data

Dim.	mm.		
	Min.	Typ.	Max.
A	175	180	185
C	12.8	13	13.2
D	20.2		
N	59.5	60	60.5
T			14.4
Ao		2.25	
Bo		2.7	
Ko		1.2	
Po	3.9	4	4.1
P	3.8	4	4.2

7 Order codes

Table 9. Order codes

Order codes	Precision	Packages	Operating temperature range	Marking
LM4041AICT-1.2	0.1%	SOT323-5L	Industrial - 40 to + 85 °C	L2
LM4041BICT-1.2	0.2%			L2
LM4041CICT-1.2	0.5%			L25
LM4041DICT-1.2	1%			L26
LM4041AILT-1.2	0.1%	SOT23-3L	Industrial - 40 to + 85 °C	L23
LM4041BILT-1.2	0.2%			L24
LM4041CILT-1.2	0.5%			L25
LM4041DILT-1.2	1%			L26
LM4041AECT-1.2	0.1%	SOT323-5L	Extended - 40 to + 125 °C	E2
LM4041BECT-1.2	0.2%			E2
LM4041CECT-1.2	0.5%			E25
LM4041DECT-1.2	1%			E26
LM4041AELT-1.2	0.1%	SOT23-3L	Extended - 40 to + 125 °C	E23
LM4041BELT-1.2	0.2%			E24
LM4041CELT-1.2	0.5%			E25
LM4041DELT-1.2	1%			E26

8 Revision history

Table 10. Document revision history

Date	Revision	Changes
09-May-2011	1	Initial release.
05-Dec-2011	2	Changed maturity code and updated Table 9 on page 14 .
25-Jul-2012	3	Added: marking order codes Table 9 on page 14 .
18-Feb-2014	4	Part number LM4041xx changed to LM4041. Updated Table 1: Absolute maximum ratings , Section 1: Pin configuration and Section 5: Package mechanical data . Added Section 6: Packaging mechanical data . Minor text changes.