

Features

- Lead Free Finish/RoHS Compliant (Note1) ("P" Suffix Designates Compliant. See Ordering Information)
- Halogen Free. "Green" Device (Note 2)
- High Surge Forward Current Capability
- Epoxy Meets UL 94 V-0 Flammability Rating
- Moisture Sensitivity Level 1

Maximum Ratings

- Operating Junction Temperature Range: -55°C to +150°C
- Storage Temperature Range: -55°C to +150°C
- Typical Thermal Resistance: 25°C/W Junction to Lead
- Typical Thermal Resistance: 62.5°C/W Junction to Ambient

MCC Part Number	Device Marking	Maximum Recurrent Peak Reverse Voltage	Maximum RMS Voltage	Maximum DC Blocking Voltage
LMB203S	LB203S	200V	140V	200V
LMB204S	LB204S	400V	280V	400V
LMB205S	LB205S	600V	420V	600V
LMB206S	LB206S	800V	560V	800V
LMB207S	LB207S	1000V	700V	1000V

Electrical Characteristics @ 25°C Unless Otherwise Specified

Average Forward Current	$I_{F(AV)}$	2.0A 1.6A	On Aluminum Substrate On Glass-Epoxy
Peak Forward Surge Current	I_{FSM}	60A 110A	8.3ms, Half Sine 1ms, Square Wave
Maximum Instantaneous Forward Voltage	V_F	0.95V	$I_{FM} = 1.0A;$ $T_A = 25^\circ C$
Maximum DC Reverse Current at Rated DC Blocking Voltage	I_R	5 μ A	$T_A = 25^\circ C$
Rating for Fusing	I^2t	15 A ² s	1ms < t < 8.30ms
Typical Junction Capacitance	C_J	12pF	$V_R = 4V, 1MHz$

Note:

1. High Temperature Solder Exemption Applied, See EU Directive Annex Notes 7a.
2. Halogen free "Green" products are defined as those which contain <900ppm bromine, <900ppm chlorine (<1500ppm total Br + Cl) and <1000ppm antimony compounds.

2.0 Amp Single Phase Glass Passivated Bridge Rectifier 200 to 1000 Volts

LMBS-1

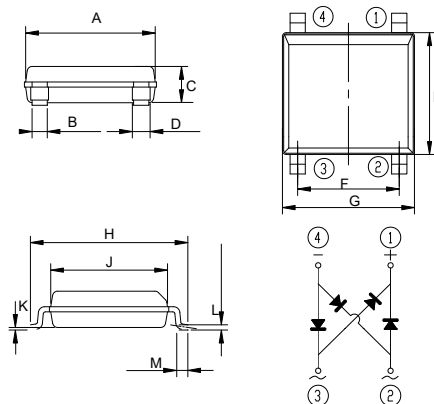

DIM	DIMENSIONS				NOTE
	INCHES		MM		
	MIN	MAX	MIN	MAX	
A	0.197	0.205	4.90	5.20	
B	0.024		0.60		
C	---	0.059	---	1.50	
D	0.024	0.032	0.60	0.80	
E	---	0.189	---	4.80	
F	0.150	0.165	3.80	4.20	
G	---	0.209	---	5.30	
H	0.236	0.252	6.00	6.60	
J	0.177	0.185	4.30	4.70	
K	0.0009	0.004	0.02	0.21	
L	0.006	0.012	0.15	0.30	
M	0.017	0.031	0.25	0.80	

Suggested Solder Pad Layout

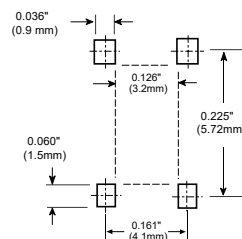

Curve Characteristics

Fig. 1 - Forward Current Derating Curve

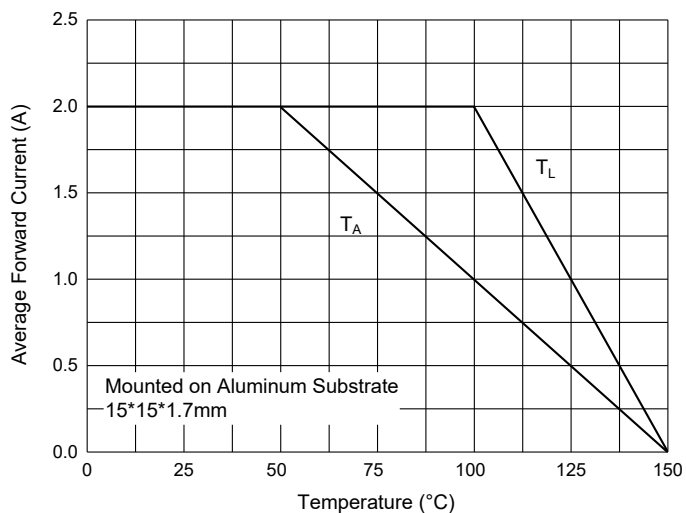

Fig. 2 - Maximum Non-Repetitive Peak Forward Surge Current

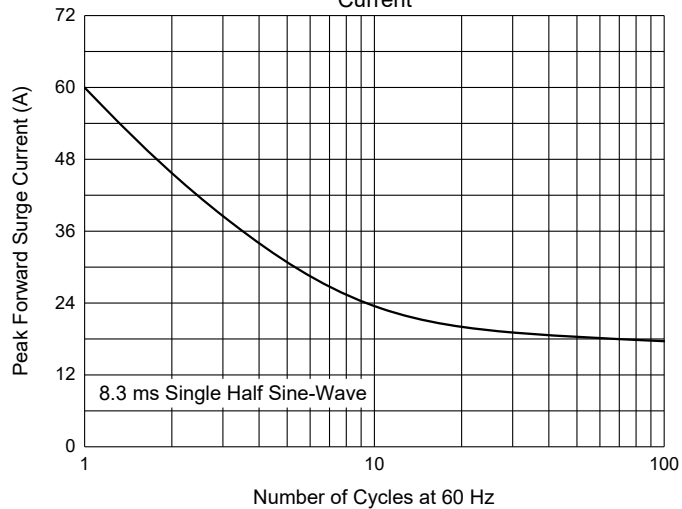

Fig. 3 - Typical Instantaneous Forward Characteristics

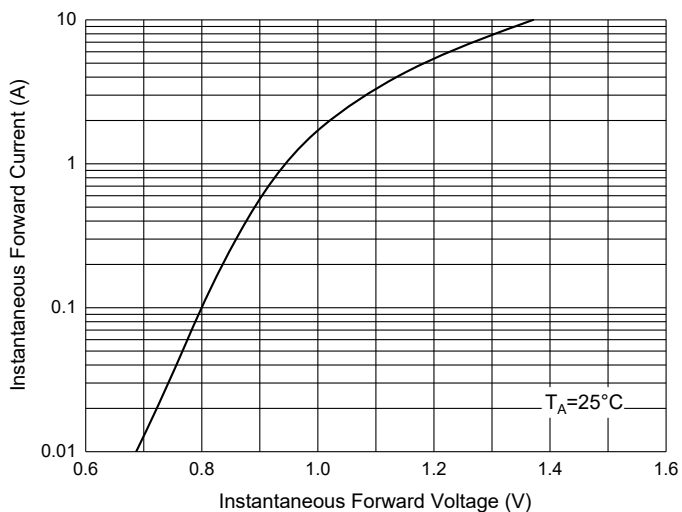

Fig. 4 - Typical Reverse Leakage Characteristics

