

# Hanging Bracket Kit

## Datasheet

Hanging bracket kit for the WLB92 series of work light

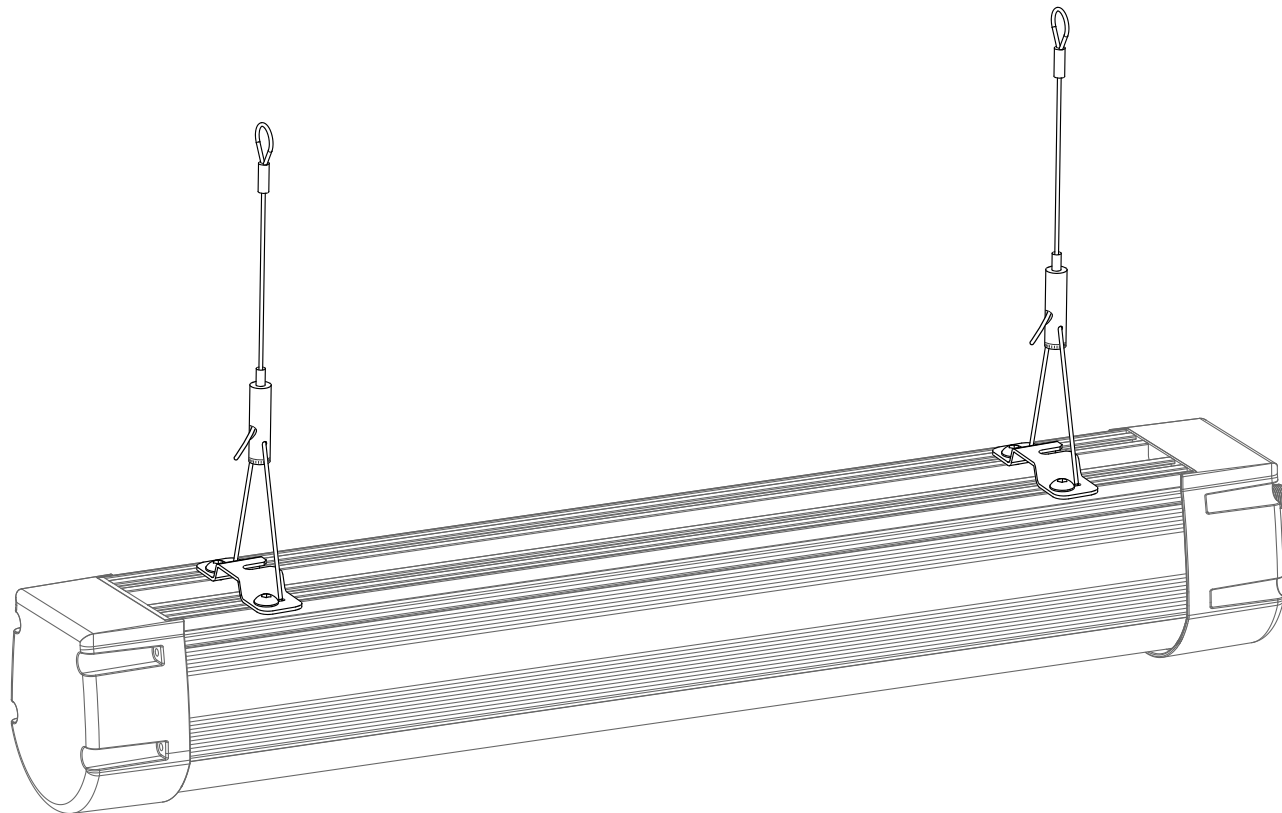

**Model:** LMBWLB92HK5



**CAUTION:** This lighting system is not intended for outdoor installations or chemical-laden environments.



**Important:** Lea el siguiente instructivo antes de operar el luminario. Por favor descargue desde [www.bannerengineering.com](http://www.bannerengineering.com) toda la documentación técnica de los Hanging Bracket Kit, disponibles en múltiples idiomas, para detalles del uso adecuado, aplicaciones, advertencias, y las instrucciones de instalación de estos dispositivos.



**Important:** Lisez les instructions suivantes avant d'utiliser le luminaire. Veuillez télécharger la documentation technique complète des Hanging Bracket Kit sur notre site [www.bannerengineering.com](http://www.bannerengineering.com) pour les détails sur leur utilisation correcte, les applications, les notes de sécurité et les instructions de montage.



## Installing and Adjusting the WLB92 Hanging Bracket Kit

To install the hanging bracket kit, assemble the bracket components as shown.

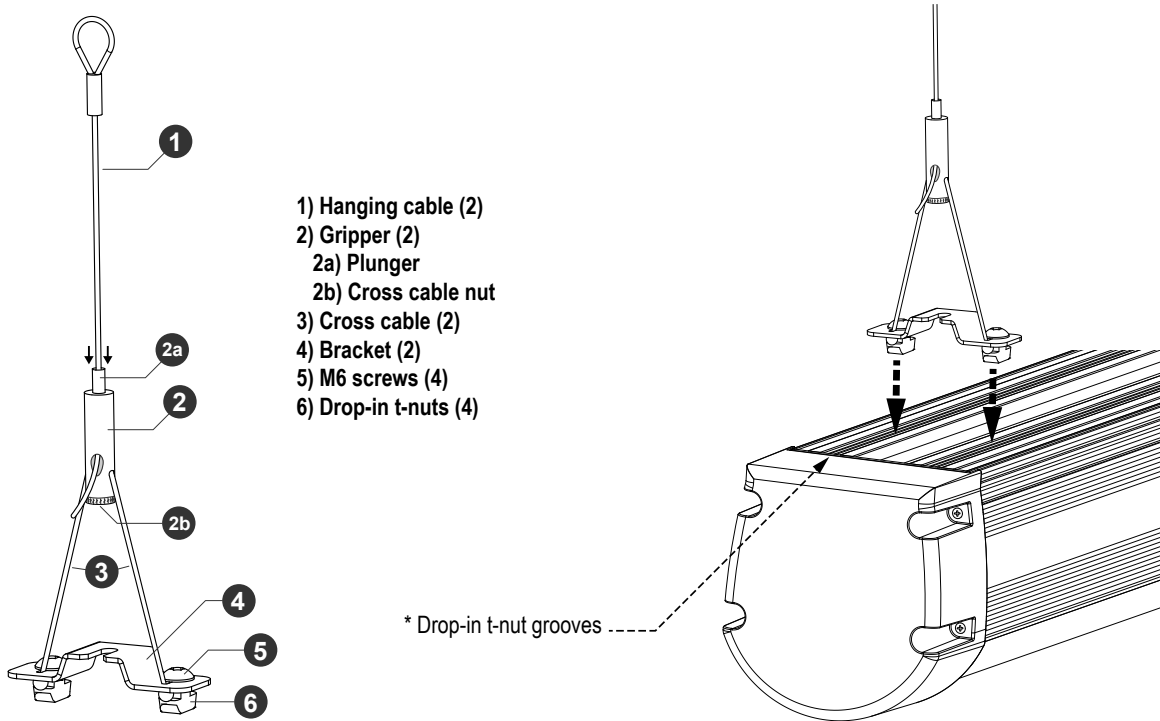

When feeding the cable through the gripper, allow at least one inch of cable beyond the gripper. Do not feed any excess cable into the light housing. To adjust the gripper position:

1. Lift all weight off the gripper.
2. Press the plunger to release the cable.
3. Slide the gripper to a new position.
4. Release the plunger.
5. Tighten the cross cable nut manually.

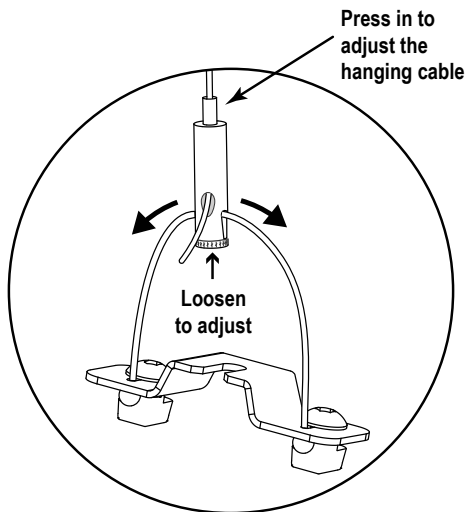

Drop-in t-nuts are automatically secured inside the grooves when they are tightened.