



LME SERIES – DIGITAL LOW DIFFERENTIAL PRESSURE SENSORS

The LME differential low-pressure sensors are based on thermal flow measurement of gas through a micro-flow channel integrated within the sensor chip. The innovative LME technology features superior sensitivity especially for ultra-low pressures. The extremely low gas flow through the sensor ensures high immunity to dust contamination and long tubing compared to other flow-based pressure sensors.

Features

- Ultra-low pressure ranges from 25 to 2500 Pa (0.1 to 10 inH₂O)
- Pressure sensor based on thermal micro-flow measurement
- High flow impedance
- very low flow-through leakage
- high immunity to dust
- no loss in sensitivity using long tubing
- Outstanding long-term stability and precision with patented real-time offset compensation and linearization techniques
- Offset long term stability better than 0.1 Pa/year
- Total accuracy better than 0.5% FS typical
- On-chip temperature sensor
- Linearized digital SPI and analog outputs
- Small footprint, low profile, only 9 mm in height, and robust package
- Pressure ports for direct manifold assemblies
- Highly versatile to fit to application-specific mounting adapters and manifolds
- Minimized internal volume and manifold mount option allow for fast gas purge time
- No position sensitivity

Media compatibility

Dry air and other non-corrosive gases

Certificates

- Quality Management System according to EN ISO 13485 and EN ISO 9001
- RoHS and REACH compliant

[CLICK HERE >](#)
CONNECT WITH A SPECIALIST

Applications

Medical

- Ventilators
- Spirometers
- CPAP
- Sleep diagnostic equipment
- Nebulizers
- Oxygen conservers/concentrators
- Insufflators/endoscopy

Industrial

- HVAC
- VAV
- Filter monitoring
- Burner control
- Fuel cells
- Gas leak detection
- Gas metering
- Fume hood
- Instrumentation
- Security systems

LME SERIES – DIGITAL LOW DIFFERENTIAL PRESSURE SENSORS

Maximum ratings

Parameter	Min.	Max.	Unit
Supply voltage V_s	4.75	5.25	V_{DC}
Output current		1	mA
Soldering recommendation			
Reflow soldering ^(1,2)			
Average preheating temperature gradient		1.5	K/s
Time above 217 °C		74	s
Time above 240 °C		30	
Peak temperature		245	°C
Cooling temperature gradient		-1.4	K/s
Wave soldering, pot temperature		260	°C
Hand soldering, tip temperature		370	
Temperature ranges			
Compensated	0	+70	°C
Operating	-20	+80	
Storage	-40	+80	
Humidity limits (non-condensing)		97	%RH
Vibration ⁽³⁾		20	g
Mechanical shock ⁽⁴⁾		500	

Pressure sensor characteristics

Description	Operating pressure	Proof pressure ⁽⁵⁾	Burst pressure ⁽⁵⁾
LMES025U	0 to 25 Pa / 0 to 0.25 mbar (0.1 inH ₂ O)	2 bar (30 psi)	5 bar (75 psi)
LMES050U	0 to 50 Pa / 0 to 0.5 mbar (0.2 inH ₂ O)		
LMES100U	0 to 100 Pa / 0 to 1 mbar (0.4 inH ₂ O)		
LMES250U	0 to 250 Pa / 0 to 2.5 mbar (1 inH ₂ O)		
LMES500U	0 to 500 Pa / 0 to 5 mbar (2 inH ₂ O)		
LMEM012U	0 to 1250 Pa / 0 to 12.5 mbar (5 inH ₂ O)		
LMEM025U	0 to 2500 Pa / 0 to 25 mbar (10 inH ₂ O)		
LMES025B	0 to ±25 Pa / 0 to ±0.25 mbar (0.1 inH ₂ O)		
LMES050B	0 to ±50 Pa / 0 to ±0.5 mbar (0.2 inH ₂ O)		
LMES100B	0 to ±100 Pa / 0 to ±1 mbar (0.4 inH ₂ O)		
LMES250B	0 to ±250 Pa / 0 to ±2.5 mbar (1 inH ₂ O)		
LMES500B	0 to ±500 Pa / 0 to ±5 mbar (2 inH ₂ O)		
LMEM012B	0 to ±1250 Pa / 0 to ±12.5 mbar (5 inH ₂ O)		
LMEM025B	0 to ±2500 Pa / 0 to ±25 mbar (10 inH ₂ O)		

Gas correction factors ⁽⁶⁾

Gas type	Correction factor
Dry air	1.0
Oxygen (O ₂)	1.07
Nitrogen (N ₂)	0.97
Argon (Ar)	0.98
Carbon dioxide (CO ₂)	0.56

LME SERIES – DIGITAL LOW DIFFERENTIAL PRESSURE SENSORS

Performance characteristics ⁽⁷⁾

(V_S=5.0 V_{DC}, T_A=20 °C, P_{Abs}=1 bara, calibrated in air, output signals is non-ratiometric to V_S)

25 Pa and 50 Pa devices

Parameter	Min.	Typ.	Max.	Unit
Noise level (RMS)		±0.01		Pa
Offset warm-up shift			less than noise	
Offset long term stability ⁽⁸⁾		±0.05	±0.1	Pa/year
Offset repeatability		±0.01		Pa
Span repeatability ^(11,12)		±0.25		% of reading
Current consumption (no load) ⁽⁹⁾		7	8	mA
Response time (t ₆₃)		5		ms
Power-on time			25	ms

Digital output

Parameter	Min.	Typ.	Max.	Unit	
Scale factor (digital output) ⁽¹⁰⁾	0 to 25/0 to ±25 Pa	1200		counts/Pa	
	0 to 50/0 to ±50 Pa	600		counts/Pa	
Zero pressure offset accuracy ⁽¹¹⁾		±0.1	±0.2	%FSS	
Span accuracy ^(11,12)		±0.4	±0.75	% of reading	
Thermal effects	Offset	5 to 55 °C		±0.2	%FSS
		0 to 70 °C		±0.4	%FSS
	Span	5 to 55 °C	±1	±1.75	% of reading
		0 to 70 °C	±2	±2.75	% of reading

Analog output (unidirectional devices)

Parameter	Min.	Typ.	Max.	Unit	
Zero pressure offset ⁽¹¹⁾	0.49	0.50	0.51	V	
Full scale output		4.50		V	
Span accuracy ^(11,12)		±0.4	±0.75	% of reading	
Thermal effects	Offset	5 to 55 °C		±15	mV
		0 to 70 °C		±30	mV
	Span	5 to 55 °C	±1.25	±2	% of reading
		0 to 70 °C	±2	±2.75	% of reading

Analog output (bidirectional devices)

Parameter	Min.	Typ.	Max.	Unit	
Zero pressure offset ⁽¹¹⁾	2.49	2.50	2.51	V	
Output	at max. specified pressure	4.50		V	
	at min. specified pressure	0.50		V	
Span accuracy ^(11,12)		±0.4	±0.75	% of reading	
Thermal effects	Offset	5 to 55 °C		±15	mV
		0 to 70 °C		±30	mV
	Span	5 to 55 °C	±1.25	±2	% of reading
		0 to 70 °C	±2	±2.75	% of reading

LME SERIES – DIGITAL LOW DIFFERENTIAL PRESSURE SENSORS

Performance characteristics (cont.) ⁽⁷⁾

(V_S=5.0 V_{DC}, T_A=20 °C, P_{Abs}=1 bara, calibrated in air, output signals is non-ratiometric to V_S)

100 Pa, 250 Pa and 500 Pa devices

Parameter	Min.	Typ.	Max.	Unit
Noise level (RMS)		±0.01		%FSS
Offset warm-up shift			less than noise	
Offset long term stability ⁽⁸⁾		±0.05	±0.1	%FSS/year
Offset repeatability ⁽¹³⁾		±0.02		Pa
Span repeatability ^(11,12)		±0.25		% of reading
Current consumption (no load) ⁽⁹⁾		7	8	mA
Response time (t ₆₃)		5		ms
Power-on time			25	ms

Digital output

Parameter	Min.	Typ.	Max.	Unit	
Scale factor (digital output) ⁽¹⁰⁾	0 to 100/0 to ±100 Pa	300		counts/Pa	
	0 to 250/0 to ±250 Pa	120			
	0 to 500/0 to ±500 Pa	60			
Zero pressure offset accuracy ⁽¹¹⁾		±0.05	±0.1	%FSS	
Span accuracy ^(11,12)		±0.4	±0.75	% of reading	
Thermal effects	Offset	5 to 55 °C		±0.1	%FSS
		0 to 70 °C		±0.2	%FSS
	Span	5 to 55 °C	±1	±1.75	% of reading
		0 to 70 °C	±2	±2.75	% of reading

Analog output (unidirectional devices)

Parameter	Min.	Typ.	Max.	Unit	
Zero pressure offset ⁽¹¹⁾	0.49	0.50	0.51	V	
Full scale output		4.50		V	
Span accuracy ^(11,12)		±0.4	±0.75	% of reading	
Thermal effects	Offset	5 to 55 °C		±10	mV
		0 to 70 °C		±12	mV
	Span	5 to 55 °C	±1	±1.75	% of reading
		0 to 70 °C	±2	±2.75	% of reading

Analog output (bidirectional devices)

Parameter	Min.	Typ.	Max.	Unit	
Zero pressure offset ⁽¹¹⁾	2.49	2.50	2.51	V	
Output	at max. specified pressure	4.50		V	
	at min. specified pressure	0.50		V	
Span accuracy ^(11,12)		±0.4	±0.75	% of reading	
Thermal effects	Offset	5 to 55 °C		±10	mV
		0 to 70 °C		±12	mV
	Span	5 to 55 °C	±1	±1.75	% of reading
		0 to 70 °C	±2	±2.75	% of reading

LME SERIES – DIGITAL LOW DIFFERENTIAL PRESSURE SENSORS

Performance characteristics ^(7,14)

(V_S=5.0 V_{DC}, T_A=20 °C, P_{Abs}=1 bara, calibrated in air, output signal is non-ratiometric to V_S)

1250 Pa and 2500 Pa devices

Parameter	Min.	Typ.	Max.	Unit
Noise level (RMS)		±0.5		Pa
Offset warm-up shift			less than noise	
Offset long term stability ⁽⁸⁾		±1.25	±2.5	Pa/year
Offset repeatability		±0.5		Pa
Span repeatability ^(11,12)		±0.25		% of reading
Current consumption (no load) ⁽⁹⁾		7	8	mA
Response time (t ₆₃)		5		ms
Power-on time			25	ms

Digital output

Parameter	Min.	Typ.	Max.	Unit	
Scale factor (digital output) ⁽¹⁰⁾	0 to 1250/0 to ±1250 Pa	24		counts/Pa	
	0 to 2500/0 to ±2500 Pa	12		counts/Pa	
Zero pressure offset accuracy ⁽¹¹⁾		±0.1	±0.2	%FSS	
Span accuracy ^(11,12)		±0.75	±1.5	% of reading	
Thermal effects	Offset	5 to 55 °C		±0.1	%FSS
		0 to 70 °C		±0.2	%FSS
	Span	5 to 55 °C	±1	±1.75	% of reading
		0 to 70 °C	±2	±2.75	% of reading

Analog output (unidirectional devices)

Parameter	Min.	Typ.	Max.	Unit	
Zero pressure offset ⁽¹¹⁾	0.49	0.5	0.51	V	
Full scale output		4.50		V	
Span accuracy ^(11,12)		±0.75	±1.5	% of reading	
Thermal effects	Offset	5 to 55 °C		±10	mV
		0 to 70 °C		±12	mV
	Span	5 to 55 °C	±1.25	±2	% of reading
		0 to 70 °C	±2	±2.75	% of reading

Analog output (bidirectional devices)

Parameter	Min.	Typ.	Max.	Unit	
Zero pressure offset ⁽¹¹⁾	2.49	2.50	2.51	V	
Output	at max. specified pressure	4.50		V	
	at min. specified pressure	0.50		V	
Span accuracy ^(11,12)		±0.75	±1.5	% of reading	
Thermal effects	Offset	5 to 55 °C		±10	mV
		0 to 70 °C		±12	mV
	Span	5 to 55 °C	±1.25	±2	% of reading
		0 to 70 °C	±2	±2.75	% of reading

Performance characteristics

Temperature sensor

Parameter	Min.	Typ.	Max.	Unit
Scale factor (digital output)		95		counts/°C
Non-linearity		±0.5		%FS
Hysteresis		±0.1		% FS

Total accuracy ⁽¹⁵⁾

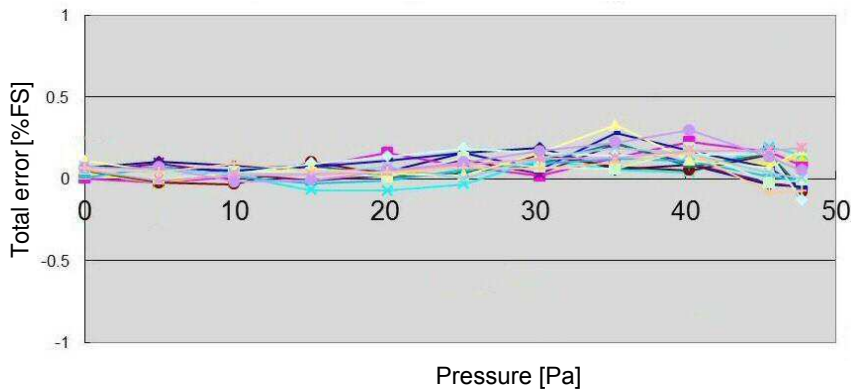

Fig. 1: Typical total accuracy plot of 16 LME 50 Pa sensors @ 25 °C (typical total accuracy better than 0.5 %FS)

Offset long term stability

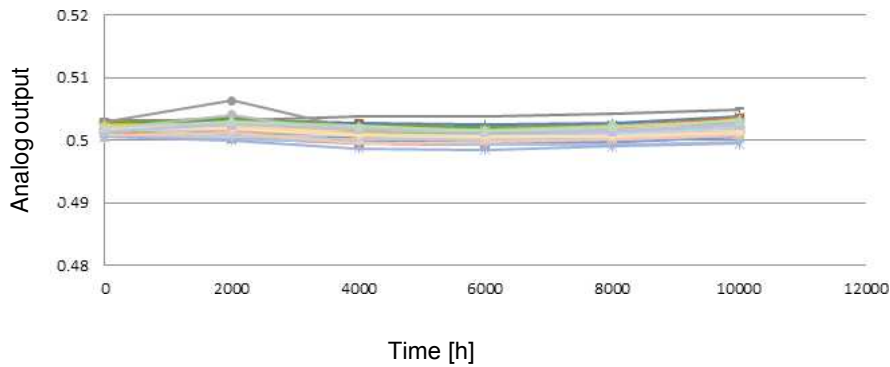

Fig. 2: Offset long term stability for LME 250 Pa sensors after 10,000 hours @ 85°C powered, equivalent to over 43.5 years @ 25 °C (better than ±2 mV / ±0.125 Pa)

SPI – Serial Peripheral Interface

Introduction

The LME serial interface is a high-speed synchronous data input and output communication port. The serial interface operates using a standard 4-wire SPI bus. The LDE device runs in SPI mode 0, which requires the clock line SCLK to idle low (CPOL = 0), and for data to be sampled on the leading clock edge (CPHA = 0). Figure 5 illustrates this mode of operation.

Care should be taken to ensure that the sensor is properly connected to the master microcontroller. Refer to the manufacturer's datasheet for more information regarding physical connections.

Application circuit

The use of pull-up resistors is generally unnecessary for SPI as most master devices are configured for push-pull mode. There are, however, some cases where it may be helpful to use 33Ω series resistors at both ends of the SPI lines, as shown in Figure 3.

Signal quality may be further improved by the addition of a buffer as shown in Figure 4. These cases include multiple slave devices on the same bus segment, using a master device with limited driving capability and long SPI bus lines.

If these series resistors are used, they must be physically placed as close as possible to the pins of the master and slave devices.

Signal control

The serial interface is enabled by asserting /CS low. The serial input clock, SCLK, is gated internally to begin accepting the input data at MOSI or sending the output data on MISO. When /CS rises, the data clocked into MOSI is loaded into an internal register.

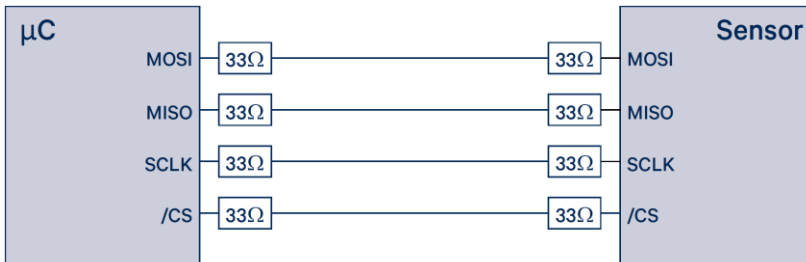

Fig. 3: Application circuit with resistors at both ends of the SPI lines

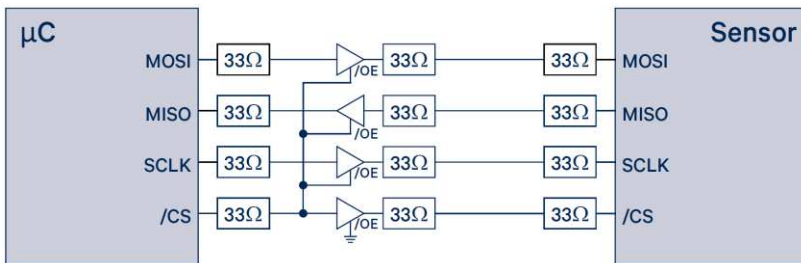

Fig. 4: Application circuit with additional buffer

SPI – Serial Peripheral Interface (cont.)

Data read – pressure

When powered on, the sensor begins to continuously measure pressure. To initiate data transfer from the sensor, the following three unique bytes must be written sequentially, MSB first, to the MOSI pin (see Figure 5):

Step	Hexadecimal	Binary	Description
1	0x2D	B00101101	Poll current pressure measurement
2	0x14	B00010100	Send result to data register
3	0x98	B10011000	Read data register

The entire 16-bit content of the LME register is then read out on the MISO pin, MSB first, by applying 16 successive clock pulses to SCLK with /CS asserted low. Note that the value of the LSB is held at zero for internal signal processing purposes. This is below the noise threshold of the sensor and thus its fixed value does not affect sensor performance and accuracy.

From the digital sensor output the actual pressure value can be calculated as follows:

$$\text{Pressure [Pa]} = \frac{\text{Digital output [counts]}}{\text{Scale factor} \left[\frac{\text{counts}}{\text{Pa}} \right]}$$

For example, for a ±250 Pa sensor (LMES250B...) with a scale factor of 120 a digital output of 30 000 counts (7530'h) calculates to a positive pressure of 250 Pa. Similarly, a digital output of -30 000 counts (8AD0'h) calculates to a negative pressure of -250 Pa

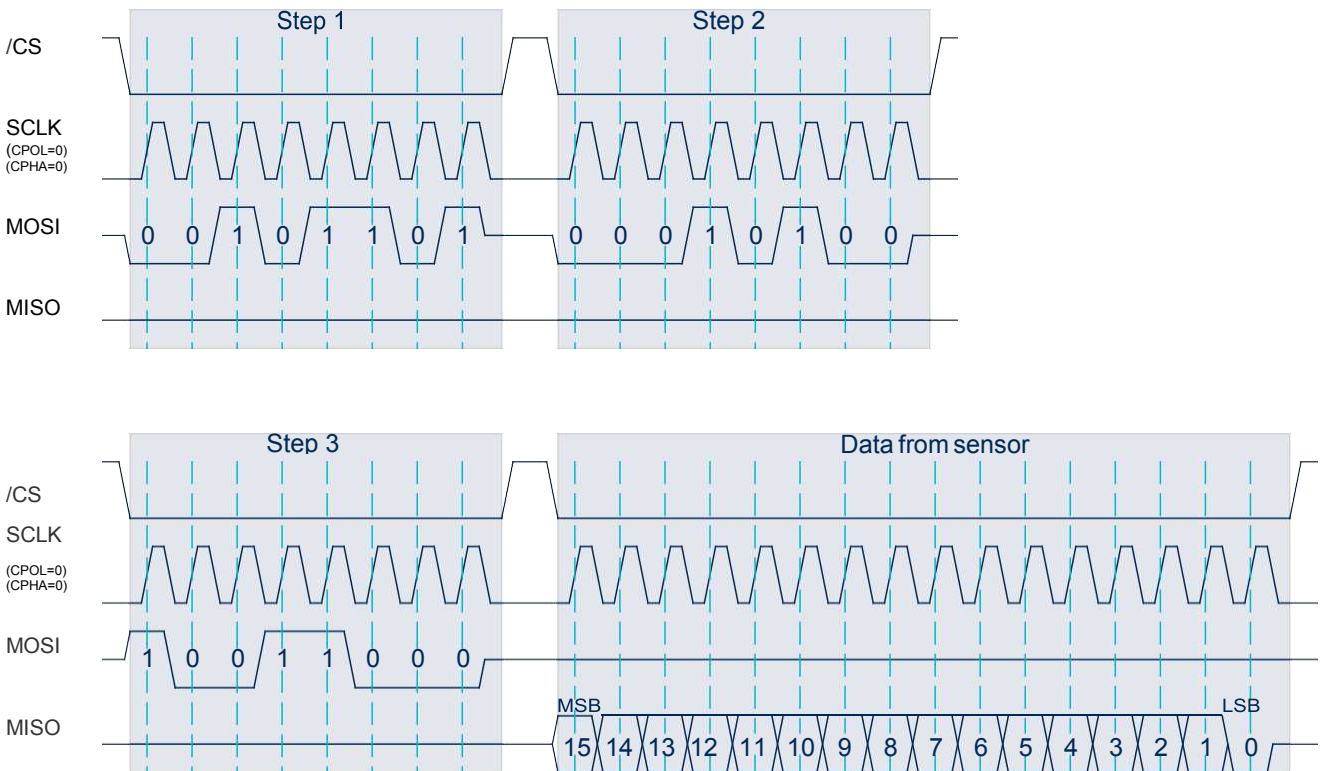

Fig. 5: SPI data transfer

LME SERIES – DIGITAL LOW DIFFERENTIAL PRESSURE SENSORS

SPI – Serial Peripheral Interface (cont.)

Data read – temperature

The on-chip temperature sensor changes 95 counts/°C over the operating range. The temperature data format is 15-bit plus sign in two's complement format. To read temperature, use the following sequence:

Step	Hexadecimal	Binary	Description
1	0x2A	B00101010	Poll current temperature measurement
2	0x14	B00010100	Send result to data register
3	0x98	B10011000	Read data register

From the digital sensor output, the actual temperature can be calculated as follows

$$\text{Temperature [}^{\circ}\text{C]} = \frac{\text{TS} - \text{TS}_0 \text{ [counts]}}{\text{Scale factor}_{\text{TS}} \left[\frac{\text{counts}}{^{\circ}\text{C}} \right]} + \text{T}_0 \text{ [}^{\circ}\text{C]}$$

where

TS is the actual sensor readout

TS₀ is the sensor readout at known temperature T⁽¹⁶⁾;

Scale factor_{TS} = 95 counts/°C

Interface specification

Parameter	Symbol	Conditions	Min.	Typ.	Max.	Unit	
External clock frequency	f _{ECLK}	V _{CKSEL} =0	Min.	0.2		MHz	
			Max.	5			
External master clock input low time	f _{ECLKIN LO}	t _{ECLK} =1/f _{ECLK}	40		60	%t _{ECLK}	
External master clock input high time	f _{ECLKIN HI}	t _{ECLK} =1/f _{ECLK}	40		60		
SCLK setup to falling edge /CS	t _{SC}		30			ns	
/CS falling edge to SCLK rising edge setup time	t _{CSS}		30				
/CS idle time	t _{CSI}	f _{CLK} =4 MHz	1.5			μs	
SCLK falling edge to data valid delay	t _{DO}	C _{LOAD} =15 pF			80	ns	
Data valid to SCLK rising edge setup time	t _{DS}		30				
Data valid to SCLK rising edge hold time	t _{DH}		30				
SCLK high pulse width	t _{CH}		100				
SCLK low pulse width	t _{CL}		100				
/CS rising edge to SCLK rising edge hold time	t _{CSH}		30				
/CS falling edge to output enable	t _{DV}	C _{LOAD} =15 pF			25		
/CS rising edge to output disable	t _{TR}	C _{LOAD} =15 pF			25		
Maximum output load capacitance	C _{LOAD}	R _{LOAD} =∞, phase margin >55°		200			pF
Input voltage, logic HIGH	V _{IH}		0.8×V _S		V _S +0.3		V
Input voltage, logic LOW	V _{IL}				0.2×V _S		
Output voltage, logic HIGH	V _{OH}	R _{LOAD} =∞	V _S -				
		R _{LOAD} =2 kΩ	V _S -				
Output voltage, logic LOW	V _{OL}	R _{LOAD} =∞			0.5		
		R _{LOAD} =2 kΩ			0.2		

SPI – Serial Peripheral Interface (cont.)

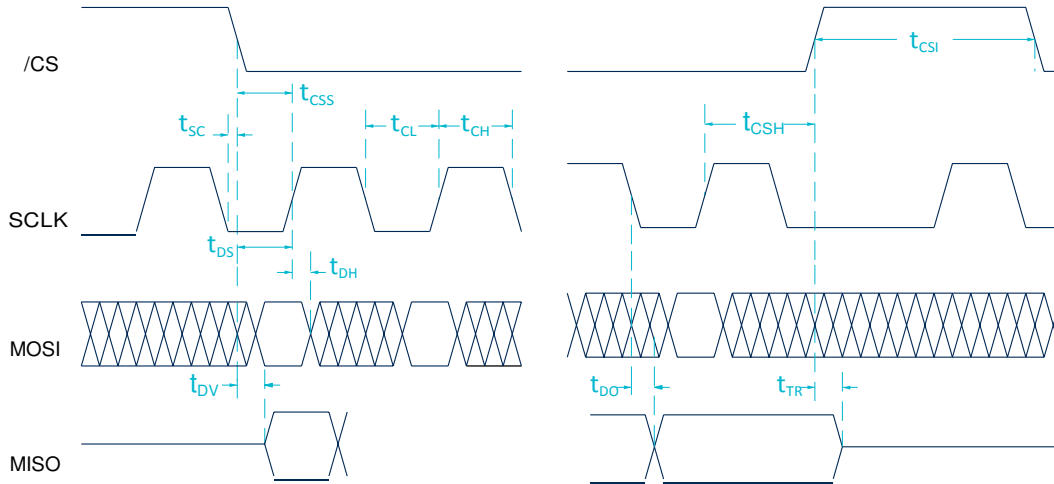
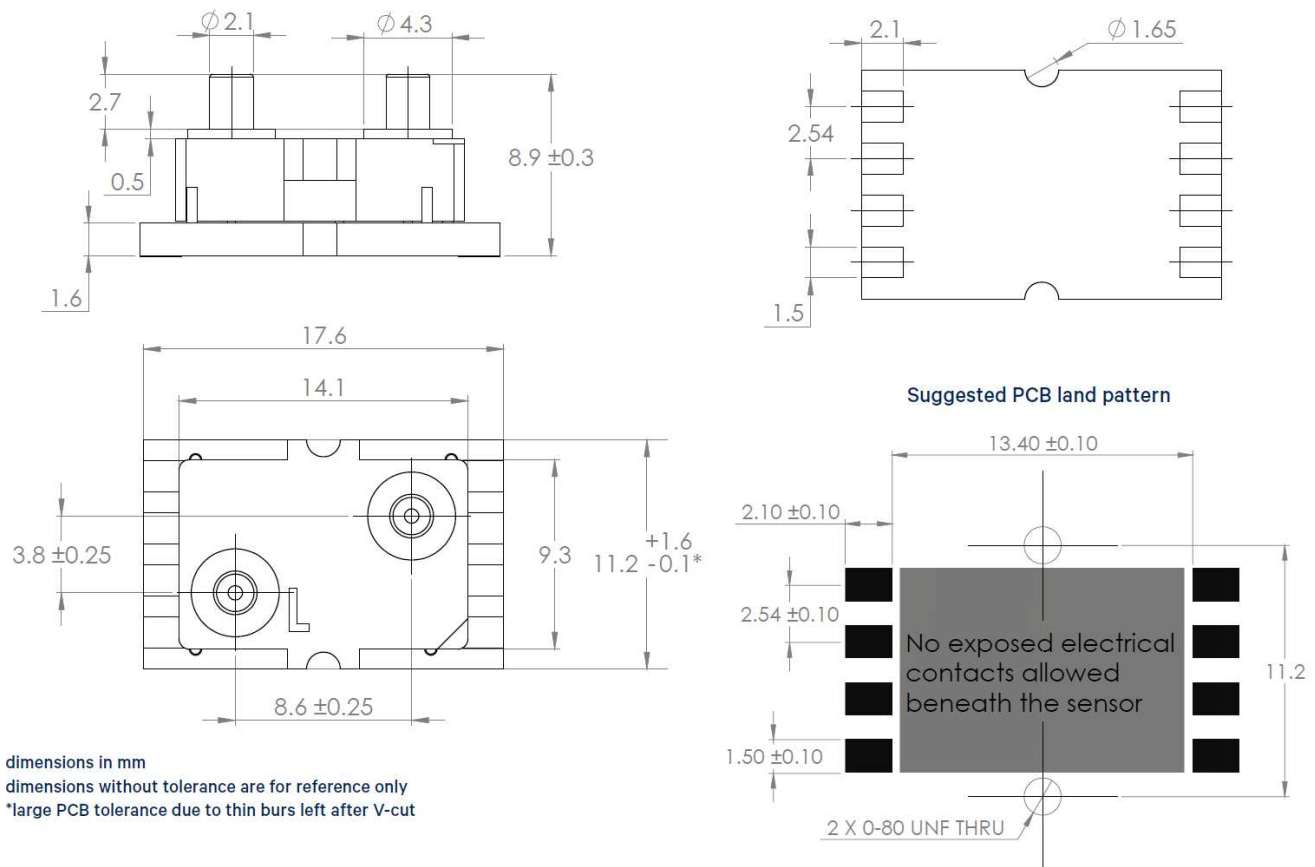

Fig. 6: SPI timing diagram

Dimensional drawing



LME SERIES – DIGITAL LOW DIFFERENTIAL PRESSURE SENSORS

Electrical connection

There are two use cases that will change the manner in which the LME series device is connected in-circuit:

Pin Function Case 1: Digital signal output Case 2: Analog signal output

Pin	Function	Case 1: Digital signal output	Case 2: Analog signal output
1	V _S	+5V	+5V
2	GND	GND	GND
3	V _{out}	NC	High impedance analog input (e.g. op-amp, ADC)
4	Reserved	NC	NC
5	SCLK	Master device SCLK	GND
6	MOSI	Master device MOSI	GND
7	MISO	Master device MISO	GND
8	/CS	Master device (/CS)	V _s

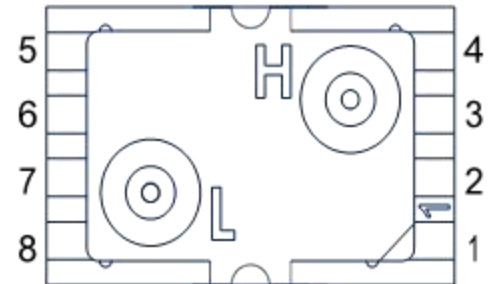

Recommended manifold dimensions for two side-by-side mounted sensors

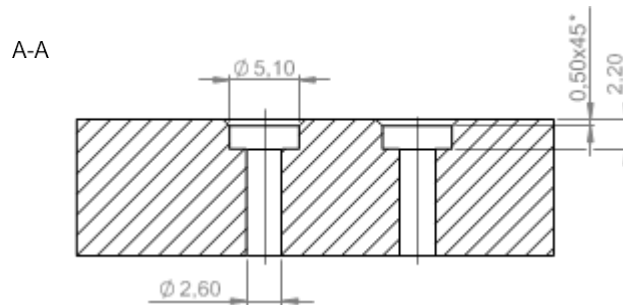

Recommended O-ring: Part number: 90025K119 www.mcmaster.com

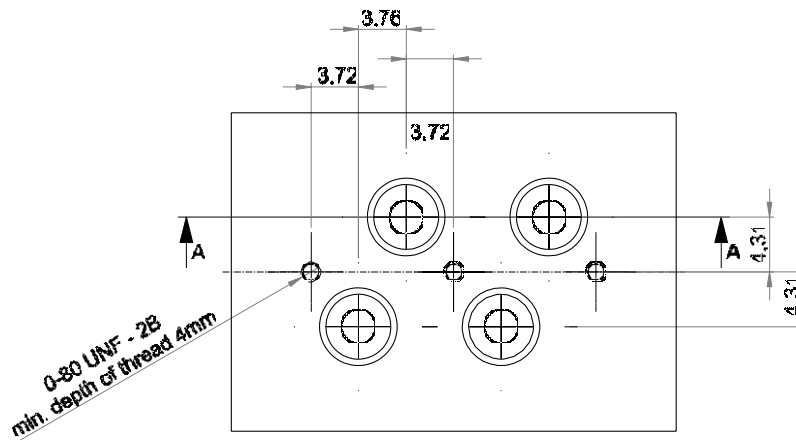

dimensions in mm and for reference only

LME SERIES – DIGITAL LOW DIFFERENTIAL PRESSURE SENSORS

Recommended manifold schematic for multiple side-by-side mounted sensors

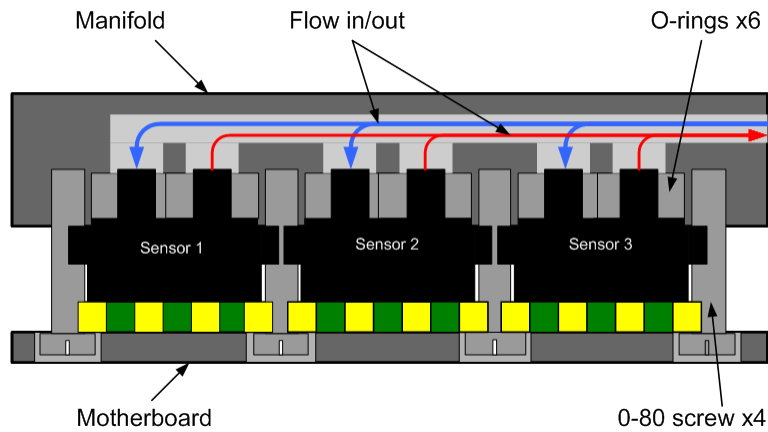

Custom adapter

The LME series pressure sensors can optionally be equipped with a custom adapter for your application-specific mounting requirements. It is designed for applications where wider port spacing and diameter are needed. Please contact First Sensor for more information.

3D views of a custom adapter for the LME pressure sensor

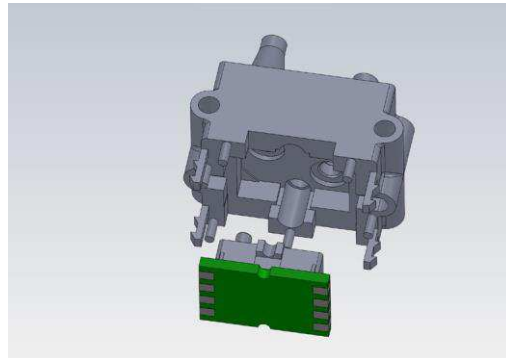
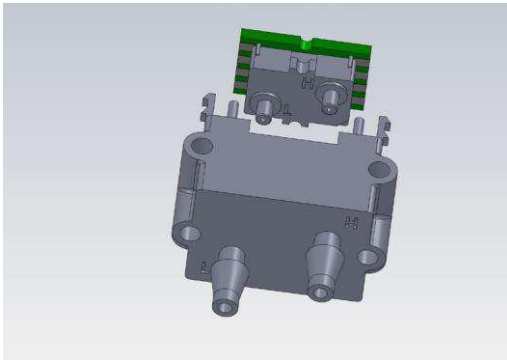

LME SERIES – DIGITAL LOW DIFFERENTIAL PRESSURE SENSORS

Dimensional drawing ZA009102 plug-in adapter

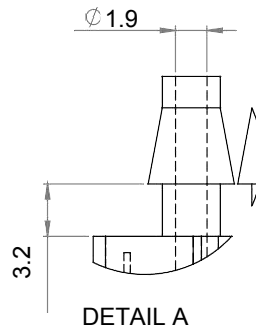
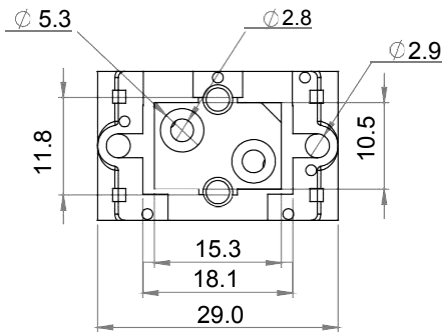
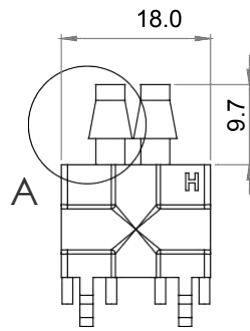
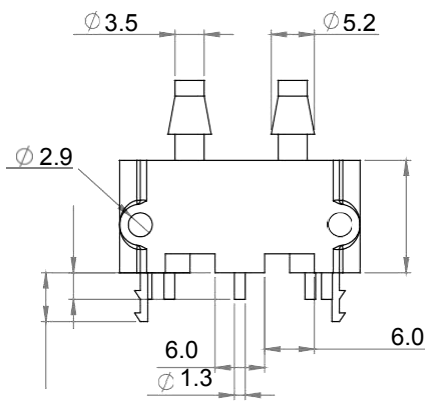

Example of PCB layout for plug-in adapter

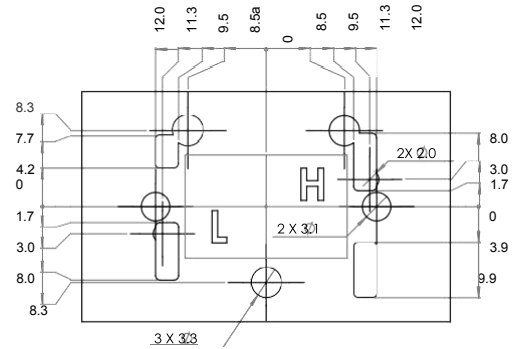

Hole pattern is provided with reference dimensions only. Please ensure that the final design allows for positioning errors of the PCB assembly process.

Dimensions in mm

Gas mixture change (purge time)

The LME series pressure sensors feature minimized internal volume, which allows for fast response to gas mixture change and high pneumatic impedance at the same time. Purge time (T_P) can be estimated by the following equation:

$$T_P = \frac{V_{INT}}{F_{Nom}} = \frac{V_{INT}}{P_{Nom} / Z_P}$$

T_P = Purge time [s]

V_{INT} = Internal volume of the LME sensor [ml]

F_{Nom} = Nominal flow [ml/s]

P_{Nom} = Nominal pressure [Pa]

Z_P = Pneumatic impedance [kPa/(ml/s)]

The typical internal volume of the LME sensor (V_{INT}) is 0.04 ml. With a pneumatic impedance (Z_P) of 15 kPa/(ml/s) and a nominal pressure (P_{Nom}) of 250 Pa, the estimated purge time (T_P) is 2.4 seconds.

LME SERIES – DIGITAL LOW DIFFERENTIAL PRESSURE SENSORS

Part numbering key

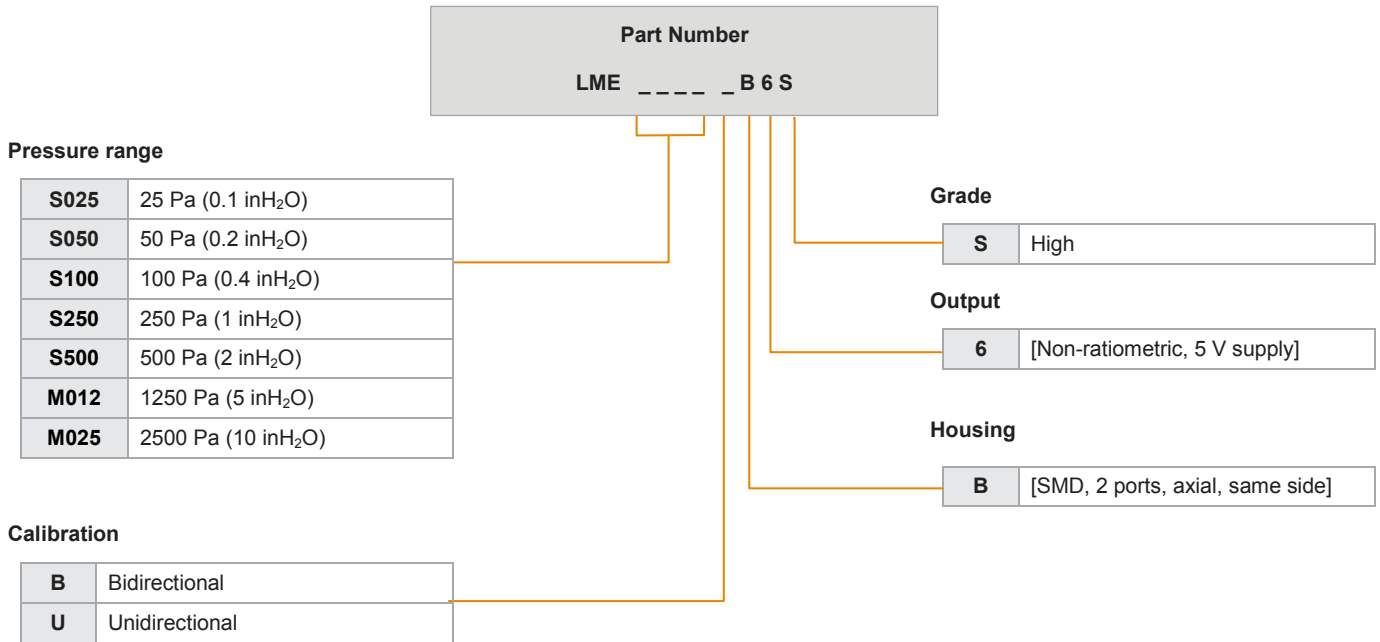

Order code example: LMES025UB6S

Accessories (order separately)

ZA009102

3004237-F (TE Part Number)

Plug-in adapter with wider port spacing and diameter

Ordering information (standard configurations)

Description	TE Part Number	Pressure Range	Calibration
LMES025UB6S	1010445-F	0 to 25 Pa	unidirectional
LMES050BB6S	1010446-F	-50 to 50 Pa	bidirectional
LMES050UB6S	1010447-F	0 to 50 Pa	unidirectional
LMES100BB6S	1010448-F	-100 to 100 Pa	bidirectional
LMES100UB6S	1010449-F	0 to 100 Pa	unidirectional
LMEM012UB6S	1010351-F	0 to 1250 Pa	unidirectional

Note:

The above product listings are examples of possible product configurations. More standard product configurations are available on request.

In addition, custom specific pressure and temperature ranges as well as mechanical or electronic sensor modifications are widely available.

Please note, not all possible sensor configurations are active products. MOQ may apply. Please contact your local sensors representative to learn more.