

LPC553x

32-bit Arm Cortex®-M33, 128 KB SRAM; 256 KB flash, FlexSPI with cache, USB FS, Flexcomm Interface, CAN FD, 32-bit counter/ timers, SCTimer/PWM, 16-bit 2.0 Msamples/sec ADC, Comparator, 12-bit DAC, OpAmp, FlexPWM Timer, QEI, Temperature Sensor, CRC

Rev. 1.0 — 04/2022

Product data sheet

1. General description

The LPC553x is an ARM Cortex-M33 based microcontroller for embedded applications. These devices include up to 256 KB on-chip flash, up to 128 KB of on-chip SRAM, FlexSPI with cache, USB Full-Speed device with crystal-less operation, USB Full-Speed Host, CAN FD, five general-purpose timers, one SCTimer/PWM, one RTC/alarm timer, one 24-bit Multi-Rate Timer (MRT), a Windowed Watchdog Timer (WWDT), Code Watchdog Timer, one OS Timer, one Micro-tick timer, eight flexible serial communication peripherals (Flexcomm Interfaces - which can be configured as a USART, SPI, high speed SPI, I2C, or I2S interface), one DMIC, one I3C interface, four 16-bit 2.0 Msamples/sec (four 12-bit 3.2 Msamples/sec) ADC capable of four simultaneous conversions, four comparators, two temperature sensors, three 12-bit 1 Msample/sec DAC, 3 OpAmps, two FlexPWM timers, and two QEIs.

2. Features and benefits

- ARM Cortex-M33 core (r0p4):
 - ◆ Running at a frequency of up to 150 MHz.
 - ◆ Integrated digital signal processing (DSP) instructions.
 - ◆ Floating Point Unit (FPU) and Memory Protection Unit (MPU).
 - ◆ ARM Cortex M33 built-in Nested Vectored Interrupt Controller (NVIC).
 - ◆ Non-maskable Interrupt (NMI) input with a selection of sources.
 - ◆ Serial Wire Debug with eight breakpoints and four watch points. Includes Serial Wire Output for enhanced debug capabilities and trace (ETM).
 - ◆ System tick timer.
- A hardware DSP accelerator for fixed and floating point DSP functions (PowerQuad). PowerQuad uses a bank of four dedicated 4 KB SRAMs
- On-chip memory:
 - ◆ Up to 256 KB on-chip flash program memory, with flash accelerator and 512 byte page erase and write, coupled with 8 KB Low Power Cache to enhance system performance.
 - ◆ Up to 128 KB total SRAM consisting of 16 KB SRAM on Code Bus, 112 KB SRAM on System Bus (112 KB is contiguous).
 - ◆ Parity support on all RAM banks except RAM1 bank. ECC support available only on RAM1 bank.
 - ◆ OTP eFuse programmable memory.



- On-chip ROM bootloader supports:
 - ◆ Booting of images from on-chip flash and external flash.
 - ◆ CRC32 image integrity checking.
 - ◆ Flash programming through In System Programming (ISP) commands over following interfaces: USB0 interfaces using HID Class device, UART interface (Flexcomm 0) with auto baud, High-Speed SPI slave interfaces (Flexcomm 8) using mode 3 (CPOL = 1 and CPHA = 1), I2C slave interface (Flexcomm 1), and CAN-FD ISP.
 - ◆ ROM API functions:
 - Flash programming API and OTP eFuse programming API.
 - ◆ Dual images (boot latest version) from on-chip flash using re-map feature.
 - ◆ Loading image to RAM from external Octal/QuadSPI device.
 - ◆ Booting Execute-in-Place (XIP) images present on Octal/QuadSPI devices.
 - ◆ Dual Execute-in-Place (XIP) images in Octal/QuadSPI flash through flash address remap feature.
 - ◆ Load-to-RAM boot mode from 1-bit SPI flash devices connected to Flexcomm (selectable by PFR) as normal boot option and recovery boot option.
 - ◆ USB Device DFU Connection (Device only).
 - ◆ Code Read protection (CRP) on non-secure devices.
 - ◆ Crystal-less USB ISP Device mode.
- Serial interfaces:
 - ◆ Flexcomm Interface contains up to eight serial peripherals (Flexcomm Interface 0-7). Each Flexcomm Interface can be selected by software to be a USART, SPI, I²C, and I²S interface. Each Flexcomm Interface includes a FIFO that supports USART, SPI, and I²S. A variety of clocking options are available to each Flexcomm Interface, including a shared fractional baud-rate generator, and time-out feature. Flexcomm interfaces 0 to 5 each provide one channel pair of I²S and Flexcomm interfaces 6 to 7 each provide four channel pairs of I²S.
 - ◆ I²C-bus interfaces support Fast-mode and Fast-mode Plus with data rates of up to 1Mbit/s and with multiple address recognition and monitor mode. Two sets of true I²C pads also support high-speed Mode (3.4 Mbit/s) as a slave.
 - ◆ High Speed SPI (Flexcomm 8, 50MHz for both master and slave).
 - ◆ A digital microphone interface supporting up to two channels with associated decimators and Voice Activation Detect. One pair of channels can be streamed directly to I²S. The DMIC supports DMA.
 - ◆ One I3C bus interface.
 - ◆ One CAN FD module with dedicated DMA controller.
 - ◆ USB 2.0 full speed host/device controller with on-chip PHY and dedicated DMA controller supporting crystal-less operation in device mode using software library example in Application Note (*AN13527, LPC55S3x/LPC553x Crystal-Less USB Solution*).
- Digital peripherals:
 - ◆ DMA0 controller with 52 channels and up to 53 programmable triggers, able to access all memories and DMA-capable peripherals.
 - ◆ DMA1 controller with 16 channels and up to 25 programmable triggers, able to access all memories and DMA-capable peripherals.

- ◆ CRC engine block can calculate a CRC on supplied data using one of three standard polynomials with DMA support. Supports programmable CRC polynomial.
- ◆ Up to 66 General-Purpose Input/Output (GPIO) pins.
- ◆ GPIO registers are located on the AHB for fast access. The DMA supports GPIO ports.
- ◆ Up to eight GPIOs can be selected as pin interrupts (PINT), triggered by rising, falling or both input edges.
- ◆ A group of up to 8 GPIO pins can be selected for boolean pattern matching, which can generate interrupts and/or drive a pattern-match output.
- ◆ Two GPIO grouped interrupts (GINT) enable an interrupt based on a logical (AND/OR) combination of input states.
- ◆ I/O pin configuration with support for up to 16 signal options.
- ◆ FlexSPI flash interface for external flash with 8 KB cache for execute-in-place and supports DMA. The FlexSPI includes 1 port: high speed channel A which supports quad or octal operation. Support dual image via address remapping.
- ◆ Two AOI (AND/OR/Invert) combinatorial logic modules with dedicated set of input and output signals. Each AOI has 4 outputs that feed to different peripheral muxes to individual peripherals.
- 128 bit unique device serial number for identification (UUID).
- Timers:
 - ◆ Five 32-bit standard general purpose asynchronous timers/counters, which support up to four capture inputs and four compare outputs, PWM mode, and external count input. Specific timer events can be selected to generate DMA requests.
 - ◆ One SCTimer/PWM with 8 input and 10 output functions (16 capture and match registers). Inputs and outputs can be routed to or from external pins and internally to or from selected peripherals. Internally, the SCTimer/PWM supports 16 captures/matches, 16 events, 32 states, and a Dither engine for improved average resolution of pulse edges.
 - ◆ 32-bit Real-time clock (RTC) with calendar feature and 1 s resolution running in the always-on power domain. Another timer in the RTC can be used for wake-up from all low power modes including deep power-down, with 1 ms resolution. The RTC is clocked by the 32 kHz FRO or 32.768 kHz external crystal.
 - ◆ Multiple-channel multi-rate 24-bit timer (MRT) for repetitive interrupt generation at up to four programmable, fixed rates.
 - ◆ Windowed Watchdog Timer (WWDT) with FRO 1 MHz as clock source.
 - ◆ The Micro-Tick Timer running from the watchdog oscillator can be used to wake-up the device from sleep and deep-sleep modes. Includes 4 capture registers with pin inputs.
 - ◆ 42-bit free running OS Timer as continuous time-base for the system, available in any reduced power modes. It has a selectable clock source. When a 32 kHz clock is selected, allows a count period of more than 4 years.
- Motor Control Subsystem: 2x FlexPWM with 4 sub-modules, providing 24 PWM outputs (it supports two 3-phase motors), and 2 Quadrature Encoder/Decoder (QEI).
- Analog peripherals:

- ◆ Four single-ended 16-bit or two differential input ADCs (selectable) with sample rate of 2.0 Msamples/sec in 16-bit mode and 3.2 Msamples/sec in 12-bit mode. Eight differential channel pairs, (or 16 single-ended channels), with multiple internal and external trigger inputs. The ADC supports four simultaneous conversions, under the control of two independent sequences.
- ◆ Integrated temperature sensor connected to both ADCs.
- ◆ One comparator in always-on domain with up to four input pins and internal reference voltage. Can be used as a wake-up source from low power modes.
- ◆ Three High Speed Comparators with up to five input pins and internal reference voltage.
- ◆ Three 12-bit DACs with sample rates of up to 1.0 MSample/sec.
- ◆ Three OpAmps with programmable VREF.
- Clock generation:
 - ◆ Internal Free Running Oscillator (FRO). This oscillator provides a selectable 96 MHz output, and a 12 MHz output (divided down from the selected higher frequency) that can be used as a system clock. The FRO is trimmed to +/- 1% accuracy over the entire voltage and 0 C to 85 C. The FRO is trimmed to +/- 2% accuracy over the entire voltage and -40 C to 105 C.
 - ◆ 32 kHz Internal Free Running Oscillator FRO. The FRO is trimmed to +/- 2% accuracy over the entire voltage and temperature range.
 - ◆ Internal low power oscillator (FRO 1 MHz) trimmed to +/- 15% accuracy over the entire voltage and temperature range.
 - ◆ Crystal oscillator with an operating frequency of 12 MHz to 32 MHz. Option for external clock input (bypass mode) for clock frequencies of up to 25 MHz.
 - ◆ Crystal oscillator with 32.768 kHz operating frequency.
 - ◆ PLL0 and PLL1 allows CPU operation up to the maximum CPU rate without the need for a high-frequency external clock. PLL0 and PLL1 can run from the internal FRO 12 MHz output, the external oscillator, internal FRO 1 MHz output, or the 32.768 kHz RTC oscillator.
 - ◆ Clock output function with divider to monitor internal clocks.
 - ◆ Frequency measurement unit for measuring the frequency of any on-chip or off-chip clock signal.
 - ◆ Each crystal oscillator has one embedded capacitor bank, where each can be used as an integrated load capacitor for the crystal oscillators. Using APIs, the capacitor banks on each crystal pin can tune the frequency for crystals with a Capacitive Load (CL) leading to conserving board space and reducing costs.
- Power-saving modes and wake-up:
 - ◆ Integrated PMU (Power Management Unit) to minimize power consumption.
 - ◆ Low power modes: Sleep, Deep-sleep with RAM retention, power-down with RAM retention and CPU retention, and deep power-down with RAM retention.
 - ◆ Configurable wake-up options from peripherals interrupts.
 - ◆ The Micro-Tick Timer running from the watchdog oscillator can be used to wake-up the device from sleep and deep-sleep modes.
 - ◆ The Real-Time Clock (RTC) running from the 32.768 kHz clock can be used to wake-up the device from sleep, deep-sleep, power-down, and deep power-down modes.
 - ◆ Power-On Reset (POR) (trip low-level of 0.705 V and trip high-level of 0.87 V).

- ◆ Brown-Out Detectors (BOD) for external VDD_MAIN and internal VDD_CORE with separate thresholds for forced reset.
- Operating from internal DC-DC converter or selectable LDO such that DC-DC converter can be bypassed.
- On-chip LDO core 1.8 V to 3.6 V.
- DC-DC power supply 1.8 V to 3.6 V.
- Two Main IO supplies (VDDIO_1: 1.8 V to 3.6 V, VDDIO_2: 1.08 v to 3.6 V).
- Separate VBAT supply 1.71 V to 3.6 V.
- JTAG boundary scan supported.
- Operating temperature range $-40\text{ }^{\circ}\text{C}$ to $+105\text{ }^{\circ}\text{C}$.
- Available in HLQFP100, HTQFP64, and HVQFN48 packages.

3. Ordering information

Table 1. Ordering information

Type number	Part Order Number ^[1]	Package		
		Name	Description	Version
LPC5536JBD100	LPC5536JBD100E LPC5536JBD100K LPC5536JBD100MP	HLQFP100	plastic low profile quad flat package; 100 leads; body 14 × 14 × 0.5mm pitch	SOT1570-3
LPC5536JBD64	LPC5536JBD64E LPC5536JBD64K LPC5536JBD64MP	HTQFP64	plastic low profile quad flat package; 64 leads; body 10 × 10 × 0.5mm pitch	SOT 855-5
LPC5534JBD100	LPC5534JBD100E LPC5534JBD100K LPC5534JBD100MP	HLQFP100	plastic low profile quad flat package; 100 leads; body 14 × 14 × 0.5mm pitch	SOT1570-3
LPC5534JBD64	LPC5534JBD64E LPC5534JBD64K LPC5534JBD64MP	HTQFP64	plastic low profile quad flat package; 64 leads; body 10 × 10 × 0.5mm pitch	SOT 855-5
LPC5534JHI48	LPC5534JHI48/00E LPC5534JHI48/00K LPC5534JHI48/00MP	HVQFN48	plastic thermal enhanced very thin quad flat package; no leads; 48 terminals; body 7 x7 x 0.85 mm	SOT619-1
LPC5536JHI48	LPC5536JHI48/00E LPC5536JHI48/00K LPC5536JHI48/00MP	HVQFN48	plastic thermal enhanced very thin quad flat package; no leads; 48 terminals; body 7 x7 x 0.85 mm	SOT619-1

- [1] E = Single Tray
K = Multi Trays (5 +1 cover tray)
MP = Tape & Reel

3.1 Ordering options

Table 2. Ordering options

Type number	Flash/KB	Total SRAM/KB	CAN FD	USB	GPIO	Flex SPI	ADC Channels	DAC Outputs	Internal DAC	Comparator	Tamper Pins	OP Amp	CRP1/2/3	DMIC
LPC5536JBD100	256	128	y	FS	66	y	23	2	1	4	4	3	y	y
LPC5536JBD64	256	128	y	-	39	y	13	1	2	4	2	3	y	y
LPC5534JBD100	128	96	y	FS	66	y	23	2	1	4	4	3	y	y
LPC5534JBD64	128	96	y	-	39	y	13	1	2	4	2	3	y	y
LPC5534JHI48	128	96	y	-	32	y	10	-	1	4	2	3	y	y
LPC5536JHI48	256	128	y	-	32	y	10	-	1	4	2	3	y	y

Remark: The last 18 pages (10 KB) are reserved on the 256 KB flash devices resulting in 246 KB internal flash memory.

4. Marking

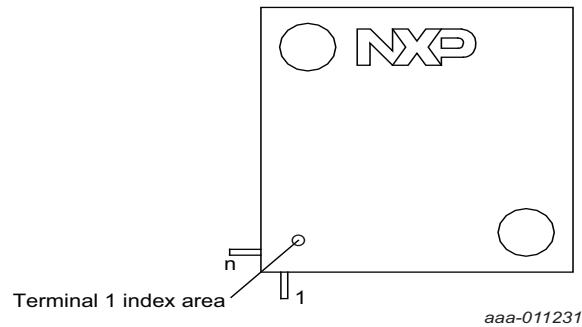

Fig 1. HLQFP100 package marking

The HLQFP100 package has the following top-side marking:

First line: LPC553x
 Second line: xxxxxx
 zzzyywwxR
 Third line: – yyww: Date code with yy = year and ww = week
 – xR: Device revision A

The HTQFP64 package has the following top-side marking:

First line: LPC553x
 Second line: JBD64
 Third line: xxxx
 Forth line: xxxx
 zzzyywwxR
 Fifth line: – yyww: Date code with yy = year and ww = week
 – xR: Device revision A

The HVQFN48 package has the following top-side marking:

First line:	LPC553x
Second line:	JHI48
Third line:	xxxxxxx
Forth line:	xxx zzzywwxR
Fifth line:	– yyww: Date code with yy = year and ww = week – xR: Device revision A

5. Block diagram

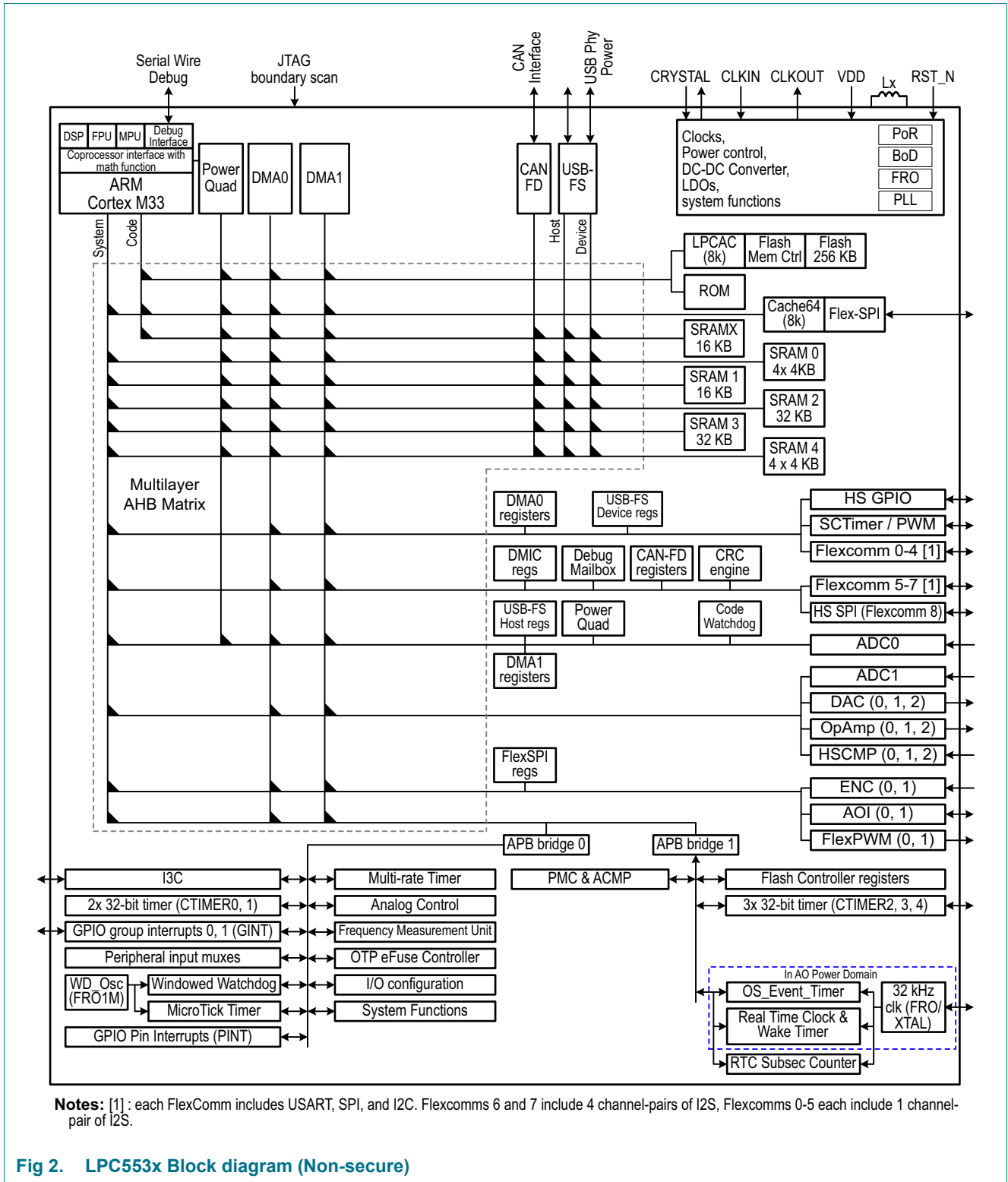

Fig 2. LPC553x Block diagram (Non-secure)

6. Pinning information

6.1 Pin description

Table 4 shows the pin functions available on each pin, and for each package. These functions are selectable using the IOCON control registers.

Some functions, such as ADC or comparator inputs, are available only on specific pins when digital functions are disabled on those pins. By default, the GPIO function is selected except on pins PIO0_0 and PIO0_9, which are the serial wire debug pins. This allows debug to operate through reset.

All pins have all pull-ups, pull-downs, and inputs turned off at reset except PIO0_0, PIO0_2, PIO0_5, PIO0_9, PIO0_13 and PIO0_14 pins. This prevents power loss through pins prior to software configuration. Due to special pin functions, some pins have a different reset configuration. PIO0_5 and PIO0_12 pins have internal pull-up enabled by default, and PIO0_0, PIO0_2, PIO0_3, and PIO0_4 have internal pull-down enabled by default. PIO0_13 and PIO0_14 are true open drain pins. Refer to pin description table for default reset configuration.

The state of port pin PIO0_5 and PIO0_7 at Reset determines the boot source of the part or if the handler is invoked.

The external reset pin or wake-up pins can trigger a wake-up from deep power-down mode. For the wake-up pins, do not assign any function to this pin if it will be used as a wake-up input when using deep power-down mode. If not in deep power-down mode, a function can be assigned to this pin. If the pin is used for wake-up, it should be pulled HIGH externally before entering deep power-down mode. A LOW-going pulse as short as 50 ns causes the chip to exit deep power-down mode wakes up the part.

The JTAG functions TRST, TCK, TMS, TDI, and TDO, are selected on pins PIO0_2 to PIO0_6 by hardware when the part is in boundary scan mode. The JTAG functions cannot be used for debug mode. To perform boundary scan testing refer to Application Note: How to Perform Boundary Scan for LPC55(S)xx.

Table 3. Pin description

Symbol	100 pin QFP100	64 pin QFP64	48 pin QFN48	Reset state [1]	Type	Function #	Description	
PIO0_0/ ACMP0_A	54	36	26	[4]	Z	I/O; AI	0	PIO0_0/ACMP0_A — General-purpose digital input/output pin. Comparator 0, input A if the DIGIMODE bit is set to 0 and ANAMODE is set to 1 in the IOCON register for this pin.
							1	R — Reserved.
						I/O	2	FC3_SCK — Flexcomm 3: USART, SPI, or I2S clock.
						O	3	CTIMER0_MAT0 — 32-bit CTimer0 match output 0.
						I	4	SCT0_GPI0 — Pin input 0 to SCTimer/PWM.

Table 3. Pin description ...continued

Symbol	100 pin QFP100	64 pin QFP64	48 pin QFN48	Reset state [1]	Type	Function #	Description
					I	5	PDM_DATA0 — PDM data input for DMIC channel 0.
						6	R — Reserved.
						7	R — Reserved.
						8	R — Reserved.
					O	9	SWCLK — Serial Wire Debug clock. This is the default function after booting. Since the internal pull-ups are disabled by default, connect external pull-up or pull-down resistor (~10 Kohm) on SWCLK pin to comply with the ARM SWD interface spec.
						10	R — Reserved.
					I/O	11	PWM1_B2 — FlexPWM1 PWMB output of SubModule2.
						12	R — Reserved.
					I	13	EXTTRIG_IN8 — Input Mux. Trigger input to selected on-chip peripherals. Please refer to INPUT MUX chapter.
						14	R — Reserved.
						15	R — Reserved.
PIO0_1/ ADC1IN2B	5	3	2	[2]	Z	I/O	PIO0_1/ADC1IN2B — General-purpose digital input/output pin. ADC1 - Analog input channel 2B. Can optionally be paired with CH2A for differential input on ADC1 channel 2.
						1	R — Reserved.
					I/O	2	FC3_CTS_SDA_SSEL0 — Flexcomm 3: USART clear-to-send, I2C data I/O, SPI Slave Select 0.
					I	3	CTIMER_INP0 — Capture input to CTIMER input muxes.
					I	4	SCT0_GPI1 — Pin input 1 to SCTimer/PWM.
					O	5	PDM_CLK0 — PDM clock output for DMIC channel 0.
						6	R — Reserved
					O	7	ACMP0_OUT — Analog comparator 0 output.
						8	R — Reserved.
						9	R — Reserved.
						10	R — Reserved.
						11	R — Reserved.
					O	12	AOIO_OUT1 — AND/OR/INVERT 0 Logic Output 1.
						13	R — Reserved.
						14	R — Reserved.
						15	R — Reserved.

Table 3. Pin description ...continued

Symbol	100 pin QFP100	64 pin QFP64	48 pin QFN48		Reset state [1]	Type	Function #	Description
PIO0_2/ TRST	81	52	38	[2]	PD	I/O	0	PIO0_2/TRST — General-purpose digital input/output pin. In boundary scan mode: TRST (Test Reset).
						I/O	1	FC3_TXD_SCL_MISO_WS — Flexcomm 3: USART transmitter, I2C clock, SPI master-in/slave-out data I/O, I2S word select/frame.
						I	2	CTIMER_INP1 — Capture input to CTIMER input multiplexers.
						O	3	SCT0_OUT0 — SCTimer/PWM output 0.
						I	4	SCT0_GPI2 — Pin input 2 to SCTimer/PWM.
						I/O	5	FLEXSPI0_DATA3 — Data bit 3 for the FlexSPI interface.
							6	R — Reserved.
							7	R — Reserved.
							8	R — Reserved.
							9	R — Reserved.
							10	R — Reserved.
						I/O	11	PWM0_A2 — FlexPWM0 PWMA output 2.
						O	12	TRIGOUT_3 — Trigger Output to pins. Please refer to IOCON chapter.
						I	13	EXTTRIG_IN4 — Input Mux. Trigger input to selected on-chip peripherals. Please refer to INPUT MUX chapter.
							14	R — Reserved.
							15	R — Reserved.
PIO0_3/TCK	84	55	40	[2]	PD	I/O	0	PIO0_3 — General-purpose digital input/output pin. In boundary scan mode: TCK (Test Clock In).
						I/O	1	FC3_RXD_SDA_MOSI_DATA — Flexcomm 3: USART receiver, I2C data I/O, SPI master-out/slave-in data, I2S data I/O.
						O	2	CTIMER0_MAT1 — 32-bit CTimer0 match output 1.
						O	3	SCT0_OUT1 — SCTimer/PWM output 1.
						I	4	SCT0_GPI3 — Pin input 3 to SCTimer/PWM.
						I/O	5	FLEXSPI0_DATA2 — Data bit 2 for the FlexSPI interface.
							6	R — Reserved.
							7	R — Reserved.
							8	R — Reserved.
							9	R — Reserved.
							10	R — Reserved.

Table 3. Pin description ...continued

Symbol	100 pin QFP100	64 pin QFP64	48 pin QFN48		Reset state [1]	Type	Function #	Description
						I/O	11	PWM1_B0 — FlexPWM1 PWMB output of SubModule0.
							12	R — Reserved.
							13	R — Reserved.
							14	R — Reserved.
							15	R — Reserved.
PIO0_4/TMS	87	57	42	[2]	PD	I/O	0	PIO0_4 — General-purpose digital input/output pin. In boundary scan mode: TMS (Test Mode Select).
						I	1	CAN0_RD — Receiver input for CAN 0.
						I/O	2	FC4_SCK — Flexcomm 4: USART, SPI, or I2S clock.
						I	3	CTIMER_INP12 — Capture input to CTIMER input multiplexers.
						I	4	SCT0_GPI4 — Pin input 4 to SCTimer/PWM.
						I/O	5	FLEXSPI0_DATA1 — Data bit 1 for the FlexSPI interface.
							6	R — Reserved.
							7	R — Reserved.
						I/O	8	FC3_CTS_SDA_SSEL0 — Flexcomm 3: USART clear-to-send, I2C data I/O, SPI Slave Select 0.
						I/O	9	FC7_TXD_SCL_MISO_WS — Flexcomm 7: USART transmitter, I2C clock, SPI master-in/slave-out data I/O, I2S word select/frame.
							10	R — Reserved.
						I/O	11	PWM0_B3 — FlexPWM0 PWMB output of SubModule3.
							12	R — Reserved.
						I	13	EXTTRIG_IN2 — Input Mux. Trigger input to selected on-chip peripherals. Please refer to INPUT MUX chapter.
							14	R — Reserved.
							15	R — Reserved.
PIO0_5/TDI	90	60	44	[2]	PU	I/O	0	PIO0_5 — General-purpose digital input/output pin. In boundary scan mode: TDI (Test Data In). Remark: The state of this pin along with PIO0_7 at Reset determines the boot source for the part of if ISP handler is invoked. See the Boot Process chapter in the Reference Manual for more details.
						O	1	CAN0_TD — Transmitter output for CAN 0.

Table 3. Pin description ...continued

Symbol	100 pin QFP100	64 pin QFP64	48 pin QFN48		Reset state [1]	Type	Function #	Description
						I/O	2	FC4_RXD_SDA_MOSI_DATA — Flexcomm 4: USART receiver, I2C data I/O, SPI master-out/slave-in data, I2S data I/O.
						O	3	CTIMER3_MAT0 — 32-bit CTimer3 match output 0.
						I	4	SCT0_GPI5 — Pin input 5 to SCTimer/PWM.
							5	R — Reserved.
							6	R — Reserved.
							7	R — Reserved.
						I/O	8	FC3_RTS_SCL_SSEL1 — Flexcomm 3: USART request-to-send, I2C clock, SPI slave select 1.
						I/O	9	MCLK — MCLK input or output for I2S.
							10	R — Reserved.
						I/O	11	PWM0_A0 — FlexPWM0 PWMA output 0.
							12	R — Reserved.
						I	13	EXTTRIG_IN5 — Input Mux. Trigger input to selected on-chip peripherals. Please refer to INPUT MUX chapter.
							14	R — Reserved.
							15	R — Reserved.
PIO0_6/TDO	89	59	43	[2]	Z	I/O	0	PIO0_6 — General-purpose digital input/output pin. In boundary scan mode: TDO (Test Data Out).
						I/O	1	FC3_SCK — Flexcomm 3: USART, SPI, or I2S clock.
						I	2	CTIMER_INP13 — Capture input to CTIMER input multiplexers.
						O	3	CTIMER4_MAT0 — 32-bit CTimer4 match output 0.
						I	4	SCT0_GPI6 — Pin input 6 to SCTimer/PWM.
						I/O	5	FLEXSPI0_DATA0 — Data bit 0 for the FlexSPI interface.
							6	R — Reserved.
							7	R — Reserved.
						O	8	SCT0_OUT6 — SCTimer/PWM output 6.
						I/O	9	FC7_RXD_SDA_MOSI_DATA — Flexcomm 7: USART receiver, I2C data I/O, SPI master-out/slave-in data, I2S data I/O.
							10	R — Reserved.
						I/O	11	PWM0_B0 — FlexPWM0 PWMB output of SubModule0.
							12	R — Reserved.

Table 3. Pin description ...continued

Symbol	100 pin QFP100	64 pin QFP64	48 pin QFN48		Reset state [1]	Type	Function #	Description
						I	13	EXTTRIG_IN1 — Input Mux. Trigger input to selected on-chip peripherals. Please refer to INPUT MUX chapter of the Reference Manual.
							14	R — Reserved.
							15	R — Reserved.
PIO0_7/ HSCMP1_IN0	42	27	20	[2]	Z	I/O	0	PIO0_7/HSCMPIN0 — General-purpose digital input/output pin. High-Speed Comparator 1, input 0. Remark: The state of this pin along with PIO0_5 at Reset determines the boot source for the part of if ISP handler is invoked. See the Boot Process chapter in the Reference Manual for more details.
						I/O	1	FC3_RTS_SCL_SSEL1 — Flexcomm 3: USART request-to-send, I2C clock, SPI slave select 1.
							2	R — Reserved.
						I/O	3	FC5_SCK — Flexcomm 5: USART, SPI, or I2S clock.
						I/O	4	FC1_SCK — Flexcomm 1: USART, SPI, or I2S clock.
						O	5	PDM_CLK0 — PDM clock output for DMIC channel 0.
							6	R — Reserved.
							7	R — Reserved.
						I	8	MCLK — MCLK input or output for I2S and/or digital microphone.
							9	R — Reserved.
							10	R — Reserved.
						I/O	11	PWM0_B0 — FlexPWM0 PWMB output of SubModule0.
						O	12	TRIGOUT_6 — Trigger Output to pins. Please refer to IOCON chapter. Input Mux.
						O	13	HSCMP2_OUT — High-Speed Comparator 2 output.
							14	R — Reserved.
							15	R — Reserved.
PIO0_8/ OPAMP0_INP	26	17	13	[2]	Z	I/O	0	PIO0_8/OPAMP_INP — General-purpose digital input/output pin. Op Amp 0 positive input.
						I/O	1	FC3_SSEL3 — Flexcomm 3: SPI slave select 3.
							2	R — Reserved.
						I/O	3	FC5_RXD_SDA_MOSI_DATA — Flexcomm 5: USART receiver, I2C data I/O, SPI master-out/slave-in data, I2S data I/O.
						O	4	SWO — Serial Wire Debug trace output.
						I/O	5	PDM_DATA1 — PDM data input for DMIC channel 1.
							6	R — Reserved.

Table 3. Pin description ...continued

Symbol	100 pin QFP100	64 pin QFP64	48 pin QFN48	Reset state [1]	Type	Function #	Description
						7	R — Reserved.
						8	R — Reserved.
						9	R — Reserved.
						10	R — Reserved.
						11	R — Reserved.
						12	R — Reserved.
						13	R — Reserved.
						14	R — Reserved.
						15	R — Reserved.
PIO0_9/ ACMP0_B	55	37	27	[4]	Z	I/O; AI	0 PIO0_9/ACMP0_B — General-purpose digital input/output pin. Comparator 0, input B if the DIGIMODE bit is set to 0 and ANAMODE is set to 1 in the IOCON register for this pin.
						I/O	1 FC3_SSEL2 — Flexcomm 3: SPI slave select 2.
							2 R — Reserved.
						I/O	3 FC5_TXD_SCL_MISO_WS — Flexcomm 5: USART transmitter, I2C clock, SPI master-in/slave-out data I/O, I2S word-select/frame.
							4 R — Reserved.
							5 R — Reserved.
							6 R — Reserved.
						I/O	7 I3C0_SCL — Clock for I3C master or slave.
							8 R — Reserved.
						I/O	9 SWDIO — Serial Wire Debug I/O. This is the default function after booting. Since the internal pull-ups are disabled by default, connect external pull-up resistor (~10 Kohm) on the SWDIO pin to comply with the ARM SWD interface spec.
							10 R — Reserved.
						O	11 PWM1_A2 — FlexPWM1 PWMA output 2.
							12 R — Reserved.
						O	13 TRIGOUT_2 — Trigger Output to pins. Please refer to IOCON chapter.Input Mux.
							14 R — Reserved.
							15 R — Reserved.
PIO0_10/ ADC0IN1A	21	14	11	[4]	Z	I/O; AI	0 PIO0_10/ADC0IN1A — General-purpose digital input/output pin. ADC0 - Analog input channel 1A.
						I/O	1 FC6_SCK — Flexcomm 6: USART, SPI, or I2S clock.

Table 3. Pin description ...continued

Symbol	100 pin QFP100	64 pin QFP64	48 pin QFN48	Reset state [1]	Type	Function #	Description
					I	2	CTIMER_INP10 — Capture input to CTIMER input multiplexers.
					O	3	CTIMER2_MAT0 — 32-bit CTimer2 match output 0.
					I/O	4	FC1_TXD_SCL_MISO_WS — Flexcomm 1: USART transmitter, I2C clock, SPI master-in/slave-out data I/O, I2S word-select/frame.
					O	5	SCT0_OUT2 — SCTimer/PWM output 2.
						6	R — Reserved.
						7	R — Reserved.
						8	R — Reserved.
						9	R — Reserved.
						10	R — Reserved.
						11	R — Reserved.
						12	R — Reserved.
						13	R — Reserved.
						14	R — Reserved.
						15	R — Reserved.
PIO0_11/ ADC1IN2A	9	7	4	[4]	PD	I/O; AI	0 PIO0_11/ADC1IN2A — General-purpose digital input/output pin. ADC1 - Analog input channel 2A. Can optionally be paired with CH2B for differential input on ADC1 channel 2.
						I/O	1 FC6_RXD_SDA_MOSI_DATA — Flexcomm 6: USART receiver, I2C data I/O, SPI master-out/slave-in data, I2S data I/O.
						O	2 CTIMER2_MAT2 — 32-bit CTimer2 match output 2.
						I	3 FREQME_GPIO_CLK_A — Frequency Measure pin clock input A.
							4 R — Reserved.
							5 R — Reserved.
							6 R — Reserved.
							7 R — Reserved.
							8 R — Reserved.
							9 R — Reserved.
							10 R — Reserved.
							11 R — Reserved.
						O	12 AOI1_OUT2 — AND/OR/INVERT 1 Logic Output 2.
							13 R — Reserved.
							14 R — Reserved.

Table 3. Pin description ...continued

Symbol	100 pin QFP100	64 pin QFP64	48 pin QFN48	Reset state [1]	Type	Function #	Description
						15	R — Reserved.
PIO0_12/ ADC1IN3A	10	-	-	[4]	PU	I/O; AI	0 PIO0_12/ADC1IN3A — ADC1 - Analog input channel 3A. Can optionally be paired with CH3B for differential input on ADC1 channel 3.
						I/O	1 FC3_TXD_SCL_MISO_WS — Flexcomm 3: USART transmitter, I2C clock, SPI master-in/slave-out data I/O, I2S word-select/frame.
							2 R — Reserved.
					I		3 FREQME_GPIO_CLK_B — Frequency Measure pin clock input B.
					I		4 SCT0_GPI7 — Pin input 7 to SCTimer/PWM.
							5 R — Reserved.
							6 R — Reserved.
					I/O		7 FC6_TXD_SCL_MISO_WS — Flexcomm 6: USART transmitter, I2C clock, SPI master-in/slave-out data I/O, I2S word-select/frame.
							8 R — Reserved.
							9 R — Reserved.
							10 R — Reserved.
							11 R — Reserved.
					O		12 AOI1_OUT1 — AND/OR/INVERT 1 Logic Output 1.
							13 R — Reserved.
							14 R — Reserved.
							15 R — Reserved.
PIO0_13	70	46	34	[3]	Z	I/O	0 PIO0_13 — General-purpose digital input/output pin. Remark: In ISP mode, this pin is set to the Flexcomm 1 I2C SDA function.
						I/O	1 FC1_CTS_SDA_SSEL0 — Flexcomm 1: USART clear-to-send, I2C data I/O, SPI Slave Select 0.
					I		2 UTICK_CAP0 — Micro-tick timer capture input 0.
					I		3 CTIMER_INP0 — Capture input to CTIMER input multiplexers.
					I		4 SCT0_GPI0 — Pin input 0 to SCTimer/PWM.
					I/O		5 FC1_RXD_SDA_MOSI_DATA — Flexcomm 1: USART receiver, I2C data I/O, SPI master-out/slave-in data, I2S data I/O.
							6 R — Reserved.
							7 R — Reserved.
							8 R — Reserved.

Table 3. Pin description ...continued

Symbol	100 pin QFP100	64 pin QFP64	48 pin QFN48		Reset state [1]	Type	Function #	Description
							9	R — Reserved.
							10	R — Reserved.
							11	R — Reserved.
							12	R — Reserved.
						I	13	EXTTRIG_IN3 — Input Mux. Trigger input to selected on-chip peripherals. Please refer to INPUT MUX chapter.
							14	R — Reserved.
							15	R — Reserved.
PIO0_14	71	47	35	[3]	Z	I/O	0	PIO0_14 — General-purpose digital input/output pin. Remark: In ISP mode, this pin is set to the Flexcomm 1 I2C SCL function.
						I/O	1	FC1_RTS_SCL_SSEL1 — Flexcomm 1: USART request-to-send, I2C clock, SPI slave select 1.
						I	2	UTICK_CAP1 — Micro-tick timer capture input 1.
						I	3	CTIMER_INP1 — Capture input to CTIMER input multiplexers.
						I	4	SCT0_GPI1 — Pin input 1 to SCTimer/PWM.
							5	R — Reserved.
						I/O	6	FC1_TXD_SCL_MISO_WS — Flexcomm 1: USART transmitter, I2C clock, SPI master-in/slave-out data I/O, I2S word-select/frame.
							7	R — Reserved.
							8	R — Reserved.
							9	R — Reserved.
							10	R — Reserved.
							11	R — Reserved.
							12	R — Reserved.
						I	13	EXTTRIG_IN2 — Input Mux. Trigger input to selected on-chip peripherals. Please refer to INPUT MUX chapter.
							14	R — Reserved.
							15	R — Reserved.
PIO0_15/ ADC0IN3A	22	15	12	[4]	Z	I/O; AI	0	PIO0_15/ADC0IN3A — General-purpose digital input/output pin. ADC0 - Analog input channel 3A. Can optionally be paired with CH3B for differential input on ADC0 channel 3.
						I/O	1	FC6_CTS_SDA_SSEL0 — Flexcomm 6: USART clear-to-send, I2C data I/O, SPI Slave Select 0.

Table 3. Pin description ...continued

Symbol	100 pin QFP100	64 pin QFP64	48 pin QFN48		Reset state [1]	Type	Function #	Description
						I	2	UTICK_CAP2 — Micro-tick timer capture input 2.
						I	3	CTIMER_INP16 — Capture input to CTIMER input multiplexers.
						O	4	SCT0_OUT2 — SCTimer/PWM output 2.
							5	R — Reserved.
							6	R — Reserved.
							7	R — Reserved.
							8	R — Reserved.
							9	R — Reserved.
							10	R — Reserved.
							11	R — Reserved.
							12	R — Reserved.
							13	R — Reserved.
							14	R — Reserved.
							15	R — Reserved.
PIO0_16/ ADC0IN3B	20	13	10	[4]	Z	I/O; AI	0	PIO0_16/ADC0IN3B — ADC0 - Analog input channel 3B. Can optionally be paired with CH3A for differential input on ADC0 channel 3.
						I/O	1	FC4_TXD_SCL_MISO_WS — Flexcomm 4: USART transmitter, I2C clock, SPI master-in/slave-out data I/O, I2S word-select/frame.
						O	2	CLKOUT — Output of the CLKOUT function.
						I	3	CTIMER_INP4 — Capture input to CTIMER input multiplexers.
							4	R — Reserved.
							5	R — Reserved.
							6	R — Reserved.
							7	R — Reserved.
							8	R — Reserved.
							9	R — Reserved.
							10	R — Reserved.
							11	R — Reserved.
						O	12	AOI0_OUT3 — AND/OR/INVERT 0 Logic Output 3.
							13	R — Reserved.
							14	R — Reserved.
							15	R — Reserved.
PIO0_17/ HSCMP2_IN0	41	26	19	[2]	Z	I/O	0	PIO0_17/HSCMP2_IN0 — General-purpose digital input/output pin. High-Speed Comparator 2, input 0.

Table 3. Pin description ...continued

Symbol	100 pin QFP100	64 pin QFP64	48 pin QFN48	Reset state [1]	Type	Function #	Description
					I/O	1	FC4_SSEL2 — Flexcomm 4: SPI slave select 2.
						2	R — Reserved.
					I	3	SCT0_GPI7 — Pin input 7 to SCTimer/PWM.
					O	4	SCT0_OUT0 — SCTimer/PWM output 0.
						5	R — Reserved.
						6	R — Reserved.
						7	R — Reserved.
					I/O	8	FC5_RXD_SDA_MOSI_DATA — Flexcomm 5: USART receiver, I2C data I/O, SPI master-out/slave-in data, I2S data I/O.
						9	R — Reserved.
						10	R — Reserved.
						11	R — Reserved.
					O	12	TRIGOUT_7 — Trigger Output to pins. Please refer to IOCON chapter.
					O	13	HSCMP1_OUT — High-Speed Comparator 1 Output.
						14	R — Reserved.
						15	R — Reserved.
PIO0_18/ ACMP0_C	56	38	28	[4]	Z	I/O; AI	0 PIO0_18/ACMP0_C — General-purpose digital input/output pin. Comparator 0, input C if the DIGIMODE bit is set to 0 and ANAMODE is set to 1 in the IOCON register for this pin.
					I/O	1	FC4_CTS_SDA_SSEL0 — Flexcomm 4: USART clear-to-send, I2C data I/O, SPI Slave Select 0.
						2	R — Reserved.
					O	3	CTIMER1_MAT0 — 32-bit CTimer1 match output 0.
					O	4	SCT0_OUT1 — SCTimer/PWM output 1.
					I/O	5	FC5_RXD_SDA_MOSI_DATA — Flexcomm 5: USART receiver, I2C data I/O, SPI master-out/slave-in data, I2S data I/O.
						6	R — Reserved.
						7	R — Reserved.
					O	8	SWO — Serial Wire Debug trace output.
						9	R — Reserved.
						10	R — Reserved.
					I/O	11	PWM1_A0 — FlexPWM1 PWMA output 0.

Table 3. Pin description ...continued

Symbol	100 pin QFP100	64 pin QFP64	48 pin QFN48		Reset state [1]	Type	Function #	Description
							12	R — Reserved.
						O	13	TRIGOUT_7 — Trigger Output to pins. Please refer to IOCON chapter.
							14	R — Reserved.
							15	R — Reserved.
PIO0_19	83	54	39	[2]	Z	I/O	0	PIO0_19 — General-purpose digital input/output pin.
						I/O	1	FC4_RTS_SCL_SSEL1 — Flexcomm 4: USART request-to-send, I2C clock, SPI slave select 1.
						I	2	UTICK_CAP0 — Micro-tick timer capture input 0.
						O	3	CTIMER0_MAT2 — 32-bit CTimer0 match output 2.
						O	4	SCT0_OUT2 — SCTimer/PWM output 2.
						O	5	FLEXSPI0_SCLK — Clock output for the FlexSPI interface.
							6	R — Reserved.
						I/O	7	FC7_TXD_SCL_MISO_WS — Flexcomm 7: USART transmitter, I2C clock, SPI master-in/slave-out data I/O, I2S word-select/frame.
							8	R — Reserved.
						I	9	FC7_SCK — Flexcomm 7: USART, SPI, or I2S clock.
							10	R — Reserved.
						I/O	11	PWM0_B1 — FlexPWM0 PWMB output of SubModule0.
						O	12	TRIGOUT_5 — Trigger Output to pins. Please refer to IOCON chapter.
						I	13	EXTTRIG_IN0 — Input Mux. Trigger input to selected on-chip peripherals. Please refer to INPUT MUX chapter.
							14	R — Reserved.
							15	R — Reserved.
PIO0_20	73	48	36	[2]	Z	I/O	0	PIO0_20 — General-purpose digital input/output pin.
						I/O	1	FC3_CTS_SDA_SSEL0 — Flexcomm 3: USART clear-to-send, I2C data I/O, SPI Slave Select 0.
						O	2	CTIMER1_MAT1 — 32-bit CTimer1 match output 1.
						I	3	CTIMER_INP15 — Capture input to CTIMER input multiplexers.
						I	4	SCT0_GPI2 — Pin input 2 to SCTimer/PWM.
							5	R — Reserved.
							6	R — Reserved.

Table 3. Pin description ...continued

Symbol	100 pin QFP100	64 pin QFP64	48 pin QFN48	Reset state [1]	Type	Function #	Description
					I/O	7	FC7_RXD_SDA_MOSI_DATA — Flexcomm 7: USART receiver, I2C data I/O, SPI master-out/slave-in data, I2S data I/O.
					I/O	8	HS_SPI_SSEL0 — Slave Select 0 for high speed SPI.
						9	R — Reserved.
						10	R — Reserved.
					I/O	11	FC4_TXD_SCL_MISO_WS — Flexcomm 4: USART transmitter, I2C clock, SPI master-in/slave-out data I/O, I2S word-select/frame.
						12	R — Reserved.
					I/O	13	PWM1_X2 — FlexPWM1 PWMX output 2.
						14	R — Reserved.
						15	R — Reserved.
PIO0_21	76	49	37	[2]	Z	0	PIO0_21 — General-purpose digital input/output pin.
					I/O	1	FC3_RTS_SCL_SSEL1 — Flexcomm 3: USART request-to-send, I2C clock, SPI slave select 1.
					I	2	UTICK_CAP3 — Micro-tick timer capture input 3.
					O	3	CTIMER3_MAT3 — 32-bit CTimer3 match output 3.
					I	4	SCT0_GPI3 — Pin input 3 to SCTimer/PWM.
					O	5	SCT0_OUT7 — SCTimer/PWM output 7.
					O	6	FLEXSPI0_SS0_N — Active low slave select 0 for the FlexSPI interface.
					I/O	7	FC7_SCK — Flexcomm 7: USART, SPI, or I2S clock.
					I/O	8	HS_SPI_SSEL3 — Slave Select 3 for high speed SPI.
					I	9	FC7_CTS_SDA_SSEL0 — Flexcomm 7: USART clear-to-send, I2C data I/O, SPI Slave Select 0.
						10	R — Reserved.
					I/O	11	PWM1_B1 — FlexPWM1 PWMB output of SubModule1.
					O	12	TRIGOUT_4 — Trigger Output to pins. Please refer to IOCON chapter.
					I	13	EXTTRIG_IN7 — Input Mux. Trigger input to selected on-chip peripherals. Please refer to INPUT MUX chapter.
						14	R — Reserved.
						15	R — Reserved.

Table 3. Pin description ...continued

Symbol	100 pin QFP100	64 pin QFP64	48 pin QFN48		Reset state [1]	Type	Function #	Description
PIO0_22	78	50	-	[2][8]	Z	I/O	0	PIO0_22 — General-purpose digital input/output pin.
						I/O	1	FC6_TXD_SCL_MISO_WS — Flexcomm 6: USART transmitter, I2C clock, SPI master-in/slave-out data I/O, I2S word-select/frame.
						I	2	UTICK_CAP1 — Micro-tick timer capture input 1.
						I	3	CTIMER_INP15 — Capture input to CTIMER input multiplexers.
						O	4	SCT0_OUT3 — SCTimer/PWM output 3.
						O	5	FLEXSPI0_SCLK_N — Inverted clock output for the FlexSPI interface.
						O	6	FLEXSPI0_SS1_N — Active low slave select 1 for the FlexSPI interface.
						I	7	USB0_VBUS — Monitors the presence of USB0 bus power.
							8	R — Reserved.
						I/O	9	FC7_RTS_SCL_SSEL1 — Flexcomm 7: USART request-to-send, I2C clock, SPI slave select 1.
							10	R — Reserved.
						I/O	11	PWM1_X0 — FlexPWM1 PWMX output 0.
							12	R — Reserved.
						I	13	EXTTRIG_IN5 — Input Mux. Trigger input to selected on-chip peripherals. Please refer to INPUT MUX chapter.
							14	R — Reserved.
							15	R — Reserved.
PIO0_23/ ADC0IN8B	19	-	-	[4]	Z	I/O; AI	0	PIO0_23/ADC0IN8B — General-purpose digital input/output pin. ADC0 - Analog input channel 8B. Can optionally be paired with CH8A for differential input on ADC0 channel 8.
						I/O	1	MCLK — MCLK input or output for I2S.
						O	2	CTIMER1_MAT2 — 32-bit CTimer1 match output 2.
						O	3	CTIMER3_MAT3 — 32-bit CTimer3 match output 3.
						O	4	SCT0_OUT4 — SCTimer/PWM output 4.
						I/O	5	FC0_CTS_SDA_SSEL0 — Flexcomm 0: USART clear-to-send, I2C data I/O, SPI Slave Select 0.
							6	R — Reserved.
							7	R — Reserved.
							8	R — Reserved.
							9	R — Reserved.

Table 3. Pin description ...continued

Symbol	100 pin QFP100	64 pin QFP64	48 pin QFN48		Reset state [1]	Type	Function #	Description
							10	R — Reserved.
							11	R — Reserved.
							12	R — Reserved.
							13	R — Reserved.
							14	R — Reserved.
							15	R — Reserved.
PIO0_24/ HSCMP0_IN0	69	45	33	[2]	Z	I/O	0	PIO0_24/HSCMP0_IN0 — General-purpose digital input/output pin. High-Speed Comparator 0, input 0.
						I/O	1	FC0_RXD_SDA_MOSI_DATA — Flexcomm 0: USART receiver, I2C data I/O, SPI master-out/slave-in data, I2S data I/O.
							2	R — Reserved.
						I	3	CTIMER_INP8 — Capture input to CTIMER input multiplexers.
						I	4	SCT0_GPI0 — Pin input 0 to SCTimer/PWM.
						I/O	5	I3C0_SDA — Data for I3C master or slave.
						O	6	TRACEDATA[0] — Trace data bit 0.
							7	R — Reserved.
							8	R — Reserved.
							9	R — Reserved.
							10	R — Reserved.
						I/O	11	PWM0_A1 — FlexPWM0 PWMA output 1.
							12	R — Reserved.
						I/O	13	PWM0_X0 — FlexPWM0 PWMX output 0.
							14	R — Reserved.
							15	R — Reserved.
PIO0_25	79	51	-	[2]	Z	I/O	0	PIO0_25 — General-purpose digital input/output pin.
						I/O	1	FC0_TXD_SCL_MISO_WS — Flexcomm 0: USART transmitter, I2C clock, SPI master-in/slave-out data I/O, I2S word-select/frame.
							2	R — Reserved.
						I	3	CTIMER_INP9 — Capture input to CTIMER input multiplexers.
						I	4	SCT0_GPI1 — Pin input 1 to SCTimer/PWM.
						O	5	R — Reserved.
						O	6	FLEXSPI0_DQS — Data strobe output for the FlexSPI interface.

Table 3. Pin description ...continued

Symbol	100 pin QFP100	64 pin QFP64	48 pin QFN48	Reset state [1]	Type	Function #	Description
					O	7	HSCMP0_OUT — High-Speed Comparator 0 Output.
						8	R — Reserved.
						9	R — Reserved.
						10	R — Reserved.
					I/O	11	PWM0_A0 — FlexPWM0 PWMA output 0.
						12	R — Reserved.
					I	13	EXTTRIG_IN6 — Input Mux. Trigger input to selected on-chip peripherals. Please refer to INPUT MUX chapter.
						14	R — Reserved.
						15	R — Reserved.
PIO0_26/ WAKEUP4/TAMPER2	60	41	30	[2][8]	Z	I/O	PIO0_26/WAKEUP4/TAMPER2 — General-purpose digital input/output pin. This pin can trigger a wake-up from deep power-down mode, can be configured as rising or falling edge. This pin can also be used to trigger Tamper Event recorder block. Remark: In ISP mode, this pin is set to the HS SPI MOSI function (Flexcomm 8).
					I/O	1	FC2_RXD_SDA_MOSI_DATA — Flexcomm 2: USART receiver, I2C data I/O, SPI master-out/slave-in data, I2S data I/O.
					O	2	CLKOUT — Output of the CLKOUT function.
					I	3	CTIMER_INP14 — Capture input to CTIMER input multiplexers.
					O	4	SCT0_OUT5 — SCTimer/PWM output 5.
					O	5	PDM_CLK0 — PDM clock output for DMIC channel 0.
						6	R — Reserved.
					I	7	USB0_IDVALUE — Indicates to the transceiver whether connected as an A-device (USB0_ID LOW) or B-device (USB0_ID HIGH).
					I/O	8	FC0_SCK — Flexcomm 0: USART, SPI, or I2S clock.
					I/O	9	HS_SPI_MOSI — Master-out/slave-in data for high speed SPI.
						10	R — Reserved.
					I/O	11	PWM0_B1 — FlexPWM0 PWMB output of SubModule1.
						12	R — Reserved.
						13	R — Reserved.
						14	R — Reserved.

Table 3. Pin description ...continued

Symbol	100 pin QFP100	64 pin QFP64	48 pin QFN48	Reset state [1]	Type	Function #	Description
						15	R — Reserved.
PIO0_27/ OPAMP1_INP	28	19	15	[2]	Z	I/O	0 PIO0_27/OPAMP1_INP — General-purpose digital input/output pin. Op Amp 1 positive input.
						I/O	1 FC2_TXD_SCL_MISO_WS — Flexcomm 2: USART transmitter, I2C clock, SPI master-in/slave-out data I/O, I2S word-select/frame.
						2	R — Reserved.
						O	3 CTIMER3_MAT2 — 32-bit CTimer3 match output 2.
						O	4 SCT0_OUT6 — SCTimer/PWM output 6.
						I	5 PDM_DATA0 — PDM data input for DMIC channel 0.
						6	R — Reserved.
						I/O	7 FC7_RXD_SDA_MOSI_DATA — Flexcomm 7: USART receiver, I2C data I/O, SPI master-out/slave-in data, I2S data I/O.
						8	R — Reserved.
						9	R — Reserved.
						10	R — Reserved.
						11	R — Reserved.
						12	R — Reserved.
						13	R — Reserved.
						14	R — Reserved.
						15	R — Reserved.
PIO0_28/ WAKEUP1/TAMPER1	66	-	-	[2][8]	Z	I/O	0 PIO0_28/WAKEUP1/TAMPER1 — General-purpose digital input/output pin. This pin can trigger a wake-up from deep power-down mode and can be configured as rising or falling edge. This pin can also be used to trigger Tamper Event recorder block.
						I/O	1 FC0_SCK — Flexcomm 0: USART, SPI, or I2S clock.
						2	R — Reserved.
						I	3 CTIMER_INP11 — Capture input to CTIMER input multiplexers.
						O	4 SCT0_OUT7 — SCTimer/PWM output 7.
						O	5 TRACEDATA[3] — Trace data bit 3.
						6	R — Reserved.
						I	7 USB0_OVERCURRENTN — USB0 bus overcurrent indicator (active low).

Table 3. Pin description ...continued

Symbol	100 pin QFP100	64 pin QFP64	48 pin QFN48		Reset state [1]	Type	Function #	Description
						O	8	I3C0_PUR — Pullup resistor control for I3C master. The I3C0_PUR function controls the SDA pull-up. It is intended to be connected to one end of an external low-value pull-up resistor (e.g., 1KOhm), with the other end connected to the SDA line. If there is no external high weak bus keeper on SDA, then add an additional external weak (e.g., 100KOhm or even 500KOhm) always-on pull-up on this line.
							9	R — Reserved.
							10	R — Reserved.
						I/O	11	PWM0_A2 — FlexPWM0 PWMA output 2.
							12	R — Reserved.
							13	R — Reserved.
							14	R — Reserved.
							15	R — Reserved.
PIO0_29	93	61	45	[2]	Z	I/O	0	PIO0_29 — General-purpose digital input/output pin. Remark: In ISP mode, this pin is set to the Flexcomm 0 USART RXD function or CAN0_RD function using ISP auto-detect.
						I/O	1	FC0_RXD_SDA_MOSI_DATA — Flexcomm 0: USART receiver, I2C data I/O, SPI master-out/slave-in data, I2S data I/O.
							2	R — Reserved.
						O	3	CTIMER2_MAT3 — 32-bit CTimer2 match output 3.
						O	4	SCT0_OUT8 — SCTimer/PWM output 8.
						O	5	TRACEDATA[2] — Trace data bit 2.
						I/O	6	FC6_RXD_SDA_MOSI_DATA — Flexcomm 6: USART receiver, I2C data I/O, SPI master-out/slave-in data, I2S data I/O.
						O	7	ACMP0_OUT — Analog comparator 0 output.
							8	R — Reserved.
							9	R — Reserved.
							10	R — Reserved.
						I/O	11	PWM0_A1 — FlexPWM0 PWMA output 1.
							12	R — Reserved.
						I	13	EXTTRIG_IN3 — Input Mux. Trigger input to selected on-chip peripherals. Please refer to INPUT MUX chapter.
							14	R — Reserved.
							15	R — Reserved.

Table 3. Pin description ...continued

Symbol	100 pin QFP100	64 pin QFP64	48 pin QFN48		Reset state [1]	Type	Function #	Description
PIO0_30	95	63	47	[2]	Z	I/O	0	PIO0_30 — General-purpose digital input/output pin. Remark: In ISP mode, this pin is set to the Flexcomm 0 USART TXD function or CAN0_TD function using ISP auto-detect.
						I/O	1	FC0_TXD_SCL_MISO_WS — Flexcomm 0: USART transmitter, I2C clock, SPI master-in/slave-out data I/O, I2S word-select/frame.
							2	R — Reserved.
						O	3	CTIMER0_MAT0 — 32-bit CTimer0 match output 0.
						O	4	SCT0_OUT9 — SCTimer/PWM output 9.
						O	5	TRACEDATA[1] — Trace data bit 1.
						O	6	CAN0_TD — Transmitter output for CAN 0.
							7	R — Reserved.
							8	R — Reserved.
						I/O	9	FC6_TXD_SCL_MISO_WS — Flexcomm 6: USART transmitter, I2C clock, SPI master-in/slave-out data I/O, I2S word-select/frame.
							10	R — Reserved.
						I/O	11	PWM1_A1 — FlexPWM1 PWMA output 1.
						O	12	AOI1_OUT0 — AND/OR/INVERT 1 Logic Output 0.
							13	R — Reserved.
							14	R — Reserved.
							15	R — Reserved.
PIO0_31/ ADC0IN8A	23	16	-	[4]	Z	I/O; AI	0	PIO0_31/ADC0IN8A — General-purpose digital input/output pin. ADC0 - Analog input channel 8A. Can optionally be paired with CH8B for differential input on ADC0 channel 8.
						I/O	1	FC0_CTS_SDA_SSEL0 — Flexcomm 0: USART clear-to-send, I2C data I/O, SPI Slave Select 0.
							2	R — Reserved.
						O	3	CTIMER0_MAT1 — 32-bit CTimer0 match output 1.
						O	4	SCT0_OUT3 — SCTimer/PWM output 3.
							5	R — Reserved.
							6	R — Reserved.
							7	R — Reserved.
							8	R — Reserved.
							9	R — Reserved.
							10	R — Reserved.
							11	R — Reserved.

Table 3. Pin description ...continued

Symbol	100 pin QFP100	64 pin QFP64	48 pin QFN48	Reset state [1]	Type	Function #	Description
					O	12	AOIO_OUT0 — AND/OR/INVERT 0 Logic Output 0.
						13	R — Reserved.
						14	R — Reserved.
						15	R — Reserved.
PIO1_0/ ADC1IN0B	6	4	3	[4]	Z	I/O; AI	PIO1_0/ADC1IN0B — General-purpose digital input/output pin. ADC1 - Analog input channel 0B. Can optionally be paired with CH0A for differential input on ADC1 channel 0.
					I/O	1	FC0_RTS_SCL_SSEL1 — Flexcomm 0: USART request-to-send, I2C clock, SPI slave select 1.
						2	R — Reserved.
					I	3	CTIMER_INP2 — Capture input to CTIMER input multiplexers.
					I	4	SCT0_GPI4 — Pin input 4 to SCTimer/PWM.
						5	R — Reserved.
						6	R — Reserved.
						7	R — Reserved.
						8	R — Reserved.
						9	R — Reserved.
						11	R — Reserved.
					O	12	AO1_OUT0 — AND/OR/INVERT 1 Logic Output 0.
						13	R — Reserved.
						14	R — Reserved.
						15	R — Reserved.
PIO1_1/ WAKEUP0/TAMPER0	59	40	29	[2]	Z	I/O	PIO1_1/WAKEUP0/TAMPER0 — General-purpose digital input/output pin. This pin can trigger a wake-up from deep power-down mode. WAKEUP pin can be configured as rising or falling edge. This pin can also be used to trigger Tamper Event recorder block. Remark: In ISP mode, this pin is set to the High Speed SPI SSEL1 function (Flexcomm 8).
					I/O	1	FC3_RXD_SDA_MOSI_DATA — Flexcomm 3: USART receiver, I2C data I/O, SPI master-out/slave-in data, I2S data I/O.
						2	R — Reserved.
					I	3	CTIMER_INP3 — Capture input to CTIMER input multiplexers.
					I	4	SCT0_GPI5 — Pin input 5 to SCTimer/PWM.
					I/O	5	HS_SPI_SSEL1 — Slave Select 1 for high speed SPI.

Table 3. Pin description ...continued

Symbol	100 pin QFP100	64 pin QFP64	48 pin QFN48	Reset state [1]	Type	Function #	Description
					O	6	TRACECLK — Trace clock.
						7	R — Reserved.
						8	R — Reserved.
						9	R — Reserved.
					O	10	RTC_ALARMOUT — RTC controlled output.
					I/O	11	PWM0_B2 — FlexPWM0 PWMB output of SubModule2.
						12	R — Reserved.
						13	R — Reserved.
						14	R — Reserved.
						15	R — Reserved.
PIO1_2	61	42	31	[2]	Z	I/O	0 PIO1_2 — General-purpose digital input/output pin. Remark: In ISP mode, this pin is set to the High Speed SPI SCK function (Flexcomm 8).
						O	1 CAN0_TD — Transmitter output for CAN 0.
							2 R — Reserved.
					O	3 CTIMER0_MAT3 — 32-bit CTimer0 match output 3.	
					I	4 SCT0_GPI6 — Pin input 6 to SCTimer/PWM.	
					O	5 PDM_CLK1 — PDM clock output for DMIC channel 1.	
					I/O	6 HS_SPI_SCK — Clock for high speed SPI.	
						7	R — Reserved.
						8	R — Reserved.
						9	R — Reserved.
						10	R — Reserved.
					I/O	11 PWM0_B0 — FlexPWM0 PWMB output of SubModule0.	
					O	12 AOIO_OUT0 — AND/OR/INVERT 0 Logic Output 0.	
						13	R — Reserved.
						14	R — Reserved.
						15	R — Reserved.
PIO1_3	62	43	32	[2]	Z	I/O	0 PIO1_3 — General-purpose digital input/output pin. Remark: In ISP mode, this pin is set to the High Speed SPI MISO function (Flexcomm 8).
					I	1 CAN0_RD — Receiver input for CAN 0.	
						2	R — Reserved.
					I/O	3 FC2_TXD_SCL_MISO_WS — Flexcomm 2: USART transmitter, I2C clock, SPI master-in/slave-out data I/O, I2S word select/frame.	

Table 3. Pin description ...continued

Symbol	100 pin QFP100	64 pin QFP64	48 pin QFN48	Reset state [1]	Type	Function #	Description
					O	4	SCT0_OUT4 — SCTimer/PWM output 4.
					I	5	PDM_DATA1 — PDM data input for DMIC channel 1.
					I/O	6	HS_SPI_MISO — Master-in/slave-out data for high speed SPI.
					O	7	USB0_PORTPWRN — USB0 VBUS drive indicator (Indicates VBUS must be driven).
						8	R — Reserved.
						9	R — Reserved.
						10	R — Reserved.
					I/O	11	PWM0_A3 — FlexPWM0 PWMA output 3.
						12	R — Reserved.
						13	R — Reserved.
						14	R — Reserved.
						15	R — Reserved.
PIO1_4	75	-	-	[2]	Z	I/O	0 PIO1_4 — General-purpose digital input/output pin.
					I/O	1	FC0_SCK — Flexcomm 0: USART, SPI, or I2S clock.
						2	R — Reserved.
					O	3	CTIMER2_MAT1 — 32-bit CTimer2 match output 1.
					O	4	SCT0_OUT0 — SCTimer/PWM output 0.
					I	5	FREQME_GPIO_CLK_A — Frequency Measure pin clock input A.
						6	R — Reserved.
					I/O	7	FC4_TXD_SCL_MISO_WS — Flexcomm 0: USART transmitter, I2C clock, SPI master-in/slave-out data I/O, I2S word select/frame.
						8	R — Reserved.
						9	R — Reserved.
						10	R — Reserved.
					O	11	PWM0_B2 — FlexPWM0 PWMB output of SubModule2.
					O	12	TRIGOUT_7 — Trigger Output to pins. Please refer to IOCON chapter.
					I	13	EXTTRIG_IN8 — Input Mux. Trigger input to selected on-chip peripherals. Please refer to INPUT MUX chapter.
						14	R — Reserved.
						15	R — Reserved.

Table 3. Pin description ...continued

Symbol	100 pin QFP100	64 pin QFP64	48 pin QFN48		Reset state [1]	Type	Function #	Description
PIO1_5/HSCMP0_IN3	35	-	-	[2]	Z	I/O	0	PIO1_5/HSCMP0_IN3 — General-purpose digital input/output pin. High-Speed Comparator 0, input 3.
						I/O	1	FC0_RXD_SDA_MOSI_DATA — Flexcomm 0: USART receiver, I2C data I/O, SPI master-out/slave-in data, I2S data I/O.
							2	R — Reserved.
						O	3	CTIMER2_MAT0 — 32-bit CTimer2 match output 0.
						I	4	SCT0_GPI0 — Pin input 0 to SCTimer/PWM.
							5	R — Reserved.
							6	R — Reserved.
							7	R — Reserved.
							8	R — Reserved.
							9	R — Reserved.
							10	R — Reserved.
						I/O	11	PWM1_A3 — FlexPWM1 PWMA output 3.
						O	12	TRIGOUT_0 — Trigger Output to pins. Please refer to IOCON chapter.
							13	R — Reserved.
							14	R — Reserved.
							15	R — Reserved.
PIO1_6	50	-	-	[2]	Z	I/O	0	PIO1_6 — General-purpose digital input/output pin.
						I/O	1	FC0_TXD_SCL_MISO_WS — Flexcomm 0: USART transmitter, I2C clock, SPI master-in/slave-out data I/O, I2S word-select/frame.
							2	R — Reserved.
						O	3	CTIMER2_MAT1 — 32-bit CTimer2 match output 1.
						I	4	SCT0_GPI3 — Pin input 3 to SCTimer/PWM.
							5	R — Reserved.
							6	R — Reserved.
							7	R — Reserved.
							8	R — Reserved.
							9	R — Reserved.
							10	R — Reserved.
						I/O	11	PWM0_A1 — FlexPWM0 PWMA output 1.
						O	12	TRIGOUT_5 — Trigger Output to pins. Please refer to IOCON chapter.
						O	13	HSCMP0_OUT — High-Speed Comparator 0 output.
							14	R — Reserved.

Table 3. Pin description ...continued

Symbol	100 pin QFP100	64 pin QFP64	48 pin QFN48		Reset state [1]	Type	Function #	Description
							15	R — Reserved.
PIO1_7/ADC1IN3B	4	-	-	[2]	Z	I/O	0	PIO1_7/ADC1IN3B — General-purpose digital input/output pin. ADC1 - Analog input channel 3B. Can optionally be paired with CH3A for differential input on ADC1 channel 3.
						I/O	1	FC0_RTS_SCL_SSEL1 — Flexcomm 0: USART request-to-send, I2C clock, SPI slave select 1.
							2	R — Reserved.
						O	3	CTIMER2_MAT2 — 32-bit CTimer2 match output 2.
						I	4	SCT0_GPI4 — Pin input 4 to SCTimer/PWM.
							5	R — Reserved.
							6	R — Reserved.
							7	R — Reserved.
							8	R — Reserved.
							9	R — Reserved.
							10	R — Reserved.
							11	R — Reserved.
						O	12	AOI1_OUT3 — AND/OR/INVERT 1 Logic Output 3.
							13	R — Reserved.
							14	R — Reserved.
							15	R — Reserved.
PIO1_8	36	-	-	[4]	Z	I/O; AI	0	PIO1_8 — General-purpose digital input/output pin.
						I/O	1	FC0_CTS_SDA_SSEL0 — Flexcomm 0: USART clear-to-send, I2C data I/O, SPI Slave Select 0.
							2	R — Reserved.
							3	R — Reserved.
						O	4	SCT0_OUT1 — SCTimer/PWM output 1.
						I/O	5	FC4_SSEL2 — Flexcomm 4: SPI slave select 2.
							6	R — Reserved.
						I/O	7	FC1_SCK — Flexcomm 1: USART, SPI, or I2S clock.
							8	R — Reserved.
							9	R — Reserved.
							10	R — Reserved.
						I/O	11	PWM0_A2 — FlexPWM0 PWMA output 2.
						O	12	AOI1_OUT2 — AND/OR/INVERT 1 Logic Output 2.

Table 3. Pin description ...continued

Symbol	100 pin QFP100	64 pin QFP64	48 pin QFN48	Reset state [1]	Type	Function #	Description
					O	13	TRIGOUT_6 — Trigger Output to pins. Please refer to IOCON chapter.
						14	R — Reserved.
						15	R — Reserved.
PIO1_9/ADC0IN0A/OPAMP0_Out//HSCMP0_IN4	25	-	-	[4]	Z	I/O; AI	PIO1_9/ADC0IN0A/OPAMP0_Out/HSCMP0_IN4 — General-purpose digital input/output pin. ADC0 - Analog input channel 0A. Can optionally be paired with CH1A for differential input on ADC0 channel 0. OpAmp 0 output. High-Speed Comparator 0, input 4.
						1	R — Reserved.
					I/O	2	FC1_SCK — Flexcomm 1: USART, SPI, or I2S clock.
					I	3	CTIMER_INP4 — Capture input to CTIMER input multiplexers.
					O	4	SCT0_OUT2 — SCTimer/PWM output 2.
					I/O	5	FC4_CTS_SDA_SSEL0 — Flexcomm 4: USART clear-to-send, I2C data I/O, SPI Slave Select 0.
						6	R — Reserved.
						7	R — Reserved.
						8	R — Reserved.
						9	R — Reserved.
						10	R — Reserved.
						11	R — Reserved.
					O	12	AOI1_OUT3 — AND/OR/INVERT 1 Logic Output 3.
						13	R — Reserved.
						14	R — Reserved.
						15	R — Reserved.
PIO1_10/HSCMP1_IN3	39	-	-	[2]	Z	I/O	PIO1_10/HSCMP1_IN3 — General-purpose digital input/output pin. High-Speed Comparator 1, input 3.
						1	R — Reserved.
					I/O	2	FC1_RXD_SDA_MOSI_DATA — Flexcomm 1: USART receiver, I2C data I/O, SPI master-out/slave-in data, I2S data I/O.
					O	3	CTIMER1_MAT0 — 32-bit CTimer1 match output 0.
					O	4	SCT0_OUT3 — SCTimer/PWM output 3.
						5	R — Reserved.
						6	R — Reserved.
						7	R — Reserved.
						8	R — Reserved.

Table 3. Pin description ...continued

Symbol	100 pin QFP100	64 pin QFP64	48 pin QFN48	Reset state [1]	Type	Function #	Description
						9	R — Reserved.
						10	R — Reserved.
					I/O	11	PWM0_X1 — FlexPWM0 PWMX output 1.
					O	12	TRIGOUT_3 — Trigger Output to pins. Please refer to the IOCON chapter.
					O	13	HSCMP2_OUT — High-Speed Comparator 2 output.
						14	R — Reserved.
						15	R — Reserved.
PIO1_11	94	62	46	[2][8] Z	I/O	0	PIO1_11 — General-purpose digital input/output pin.
						1	R — Reserved.
					I/O	2	FC1_TXD_SCL_MISO_WS — Flexcomm 1: USART transmitter, I2C clock, SPI master-in/slave-out data I/O, I2S word-select/frame.
					I	3	CTIMER_INP5 — Capture input to CTIMER input multiplexers.
					I	4	USB0_VBUS — Monitors the presence of USB0 bus power.
						5	R — Reserved.
						6	R — Reserved.
					I/O	7	HS_SPI_SSEL0 — Slave Select 0 for high speed SPI.
						8	R — Reserved.
						9	R — Reserved.
					I/O	10	FC6_SCK — Flexcomm 6: USART, SPI, or I2S clock.
					I/O	11	PWM0_A0 — FlexPWM0 PWMA output 0.
						12	R — Reserved.
					I	13	EXTTRIG_IN8 — Input Mux. Trigger input to selected on-chip peripherals. Please refer to INPUT MUX chapter.
						14	R — Reserved.
						15	R — Reserved.
PIO1_12/ HSCMP0_IN1	67	-	-	[2][8] Z	I/O	0	PIO1_12/HSCMP0_IN1 — General-purpose digital input/output pin. High-Speed Comparator 0, input 1.
						1	R — Reserved.
					I/O	2	FC6_SCK — Flexcomm 6: USART, SPI, or I2S clock.
					O	3	CTIMER1_MAT1 — 32-bit CTimer1 match output 1.
					O	4	USB0_PORTPWRN — USB0 VBUS drive indicator (Indicates VBUS must be driven).

Table 3. Pin description ...continued

Symbol	100 pin QFP100	64 pin QFP64	48 pin QFN48	Reset state [1]	Type	Function #	Description
					I/O	5	HS_SPI_SSEL2 — Slave Select 2 for high speed SPI.
						6	R — Reserved.
						7	R — Reserved.
						8	R — Reserved.
						9	R — Reserved.
						10	R — Reserved.
					I/O	11	PWM0_A3 — FlexPWM0 PWMA output 3.
					O	12	AOIO_OUT1 — AND/OR/INVERT 0 Logic Output 1.
					I	13	EXTTRIG_IN9 — Input Mux. Trigger input to selected on-chip peripherals. Please refer to INPUT MUX chapter.
						14	R — Reserved.
						15	R — Reserved.
PIO1_13/ACMP0VREF	58	39	-	[2][8] Z	I/O	0	PIO1_13/ACMP0VREF — General-purpose digital input/output pin. Alternate reference voltage for the analog comparator.
						1	R — Reserved.
					I/O	2	FC6_RXD_SDA_MOSI_DATA — Flexcomm 6: USART receiver, I2C data I/O, SPI master-out/slave-in data, I2S data I/O.
					I	3	CTIMER_INP6 — Capture input to CTIMER input multiplexers.
					I	4	USB0_OVERCURRENTN — USB0 bus overcurrent indicator (active low).
					O	5	USB0_FRAME — USB0 frame toggle signal.
						6	R — Reserved.
						7	R — Reserved.
					O	8	SCT0_OUT8 — SCTimer/PWM output 8.
						9	R — Reserved.
						10	R — Reserved.
					I/O	11	PWM1_X1 — FlexPWM1 PWMX output 1.
					O	12	AOIO_OUT2 — AND/OR/INVERT 0 Logic Output 2.
						13	R — Reserved.
						14	R — Reserved.
						15	R — Reserved.

Table 3. Pin description ...continued

Symbol	100 pin QFP100	64 pin QFP64	48 pin QFN48	Reset state [1]	Type	Function #	Description	
PIO1_14/ ACMP0_D	57	-	-	[4] [8]	Z	I/O; AI	0	PIO1_14/ACMP0_D — General-purpose digital input/output pin. Comparator 0, input D if the DIGIMODE bit is set to 0 and ANAMODE is set to 1 in the IOCON register for this pin.
							1	R — Reserved.
							2	UTICK_CAP2 — Micro-tick timer capture input 2.
							3	CTIMER1_MAT2 — 32-bit CTimer1 match output 2.
							4	FC5_CTS_SDA_SSEL0 — Flexcomm 5: USART clear-to-send, I2C data I/O, SPI Slave Select 0.
							5	USB0_LEDN — USB0-configured LED indicator (active low).
							6	R — Reserved.
							7	R — Reserved.
							8	R — Reserved.
							9	R — Reserved.
							10	R — Reserved.
							11	PWM0_B3 — FlexPWM0 PWMB output of SubModule3.
							12	R — Reserved.
							13	EXTTRIG_IN9 — Input Mux. Trigger input to selected on-chip peripherals. Please refer to INPUT MUX chapter.
							14	R — Reserved.
15	R — Reserved.							
PIO1_15	82	53	-	[2]	Z	I/O	0	PIO1_15 — General-purpose digital input/output pin.
							1	R — Reserved.
							2	UTICK_CAP3 — Micro-tick timer capture input 3.
							3	CTIMER_INP7 — Capture input to CTIMER input multiplexers.
							4	FC5_RTS_SCL_SSEL1 — Flexcomm 5: USART request-to-send, I2C clock, SPI slave select 1.
							5	FC4_RTS_SCL_SSEL1 — Flexcomm 4: USART request-to-send, I2C clock, SPI slave select 1.
							6	R — Reserved.
							7	R — Reserved.
							8	FLEXSPI0_DATA5 — Data bit 5 for the FlexSPI interface.
							9	FC1_SCK — Flexcomm 1: USART, SPI, or I2S clock.
10	R — Reserved.							

Table 3. Pin description ...continued

Symbol	100 pin QFP100	64 pin QFP64	48 pin QFN48	Reset state [1]	Type	Function #	Description
					I/O	11	PWM0_B0 — FlexPWM0 PWMB output of SubModule0.
						12	R — Reserved.
					I	13	EXTTRIG_IN8 — Input Mux. Trigger input to selected on-chip peripherals. Please refer to INPUT MUX chapter.
						14	R — Reserved.
						15	R — Reserved.
PIO1_16	88	58	-	[2]	Z	I/O	PIO1_16 — General-purpose digital input/output pin.
						1	R — Reserved.
					I/O	2	FC6_TXD_SCL_MISO_WS — Flexcomm 6: USART transmitter, I2C clock, SPI master-in/slave-out data I/O, I2S word-select/frame.
					O	3	CTIMER1_MAT3 — 32-bit CTimer1 match output 3.
						4	R — Reserved.
						5	R — Reserved.
						6	R — Reserved.
						7	R — Reserved.
					I/O	8	FLEXSPI0_DATA4 — Data bit 4 for the FlexSPI interface.
					I/O	9	FC1_RXD_SDA_MOSI_DATA — Flexcomm 1: USART receiver, I2C data I/O, SPI master-out/slave-in data, I2S data I/O.
						10	R — Reserved.
					I/O	11	PWM0_B2 — FlexPWM0 PWMB output of SubModule2.
						12	R — Reserved.
					I	13	EXTTRIG_IN7 — Input Mux. Trigger input to selected on-chip peripherals. Please refer to INPUT MUX chapter.
						14	R — Reserved.
						15	R — Reserved.
PIO1_17	91	-	-	[2]	Z	I/O	PIO1_17 — General-purpose digital input/output pin.
						1	R — Reserved.
						2	R — Reserved.
					I/O	3	FC6_RTS_SCL_SSEL1 — Flexcomm 6: USART request-to-send, I2C clock, SPI slave select 1.
					O	4	SCT0_OUT4 — SCTimer/PWM output 4.
						5	R — Reserved.

Table 3. Pin description ...continued

Symbol	100 pin QFP100	64 pin QFP64	48 pin QFN48	Reset state [1]	Type	Function #	Description
						6	R — Reserved.
						7	R — Reserved.
						8	R — Reserved.
						9	R — Reserved.
						10	R — Reserved.
					I/O	11	PWM0_B0 — FlexPWM0 PWMB output of SubModule0.
					O	12	AOI1_OUT3 — AND/OR/INVERT 1 Logic Output 3.
						13	R — Reserved.
						14	R — Reserved.
						15	R — Reserved.
PIO1_18/ WAKEUP2/TAMPER3	64	-	-	[2]	Z	I/O	0 PIO1_18/WAKEUP2/TAMPER3 — General-purpose digital input/output pin. This pin can trigger a wake-up from deep power-down mode. WAKEUP pin can be configured as rising or falling edge. This pin can also be used to trigger Tamper Event recorder block.
						1	R — Reserved.
						2	R — Reserved.
						3	R — Reserved.
					O	4	SCT0_OUT5 — SCTimer/PWM output 5.
						5	R — Reserved.
						6	R — Reserved.
						7	R — Reserved.
					O	8	RTC_ALARMOUT — RTC controlled output.
						9	R — Reserved.
						10	R — Reserved.
					I/O	11	PWM0_A2 — FlexPWM0 PWMA output 2.
						12	R — Reserved.
					O	13	HSCMP2_OUT — High-Speed Comparator 2 Output.
						14	R — Reserved.
						15	R — Reserved.
PIO1_19/DAC1_OUT/AD C0IN4B/HSCMP1_IN5	30	-	-	[4]	Z	I/O; AI	0 PIO1_19/DAC1_OUT/ADC0IN4B/HSCMP1_IN5 — General-purpose digital input/output pin. DAC1 Output. ADC0 - Analog input channel 4B. Can optionally be paired with CH4A for differential input on ADC0 channel 4. High-Speed Comparator 0, input 5.
						1	R — Reserved.
					O	2	SCT0_OUT7 — SCTimer/PWM output 7.

Table 3. Pin description ...continued

Symbol	100 pin QFP100	64 pin QFP64	48 pin QFN48	Reset state [1]	Type	Function #	Description
					O	3	CTIMER3_MAT1 — 32-bit CTimer3 match output 1.
					I	4	SCT0_GPI7 — Pin input 7 to SCTimer/PWM.
					I/O	5	FC4_SCK — Flexcomm 4: USART, SPI, or I2S clock.
						6	R — Reserved.
						7	R — Reserved.
						8	R — Reserved.
						9	R — Reserved.
						10	R — Reserved.
						11	R — Reserved.
						12	R — Reserved.
					O	13	AOI1_OUT2 — AND/OR/INVERT 1 Logic Output 2.
						14	R — Reserved.
						15	R — Reserved.
PIO1_20/ADC1IN8A	11	-	-	[2]	Z	I/O	0 PIO1_20/ADC1IN8A — General-purpose digital input/output pin. Analog input channel 8A. Can optionally be paired with CH8B for differential input on ADC1 channel 8.
						I/O	1 FC7_RTS_SCL_SSEL1 — Flexcomm 7: USART request-to-send, I2C clock, SPI slave select 1.
							2 R — Reserved.
					I	3	CTIMER_INP14 — Capture input to CTIMER input multiplexers.
							4 R — Reserved.
					I/O	5	FC4_TXD_SCL_MISO_WS — Flexcomm 4: USART transmitter, I2C clock, SPI master-in/slave-out data I/O, I2S word-select/frame.
							6 R — Reserved.
							7 R — Reserved.
							8 R — Reserved.
							9 R — Reserved.
							10 R — Reserved.
					O	11	PWM0_A0 — FlexPWM0 PWMA output 0.
					O	12	AOI0_OUT1 — AND/OR/INVERT 0 Logic Output 1.
							13 R — Reserved.
							14 R — Reserved.
							15 R — Reserved.
PIO1_21	37	-	-	[2]	Z	I/O	0 PIO1_21 — General-purpose digital input/output pin.

Table 3. Pin description ...continued

Symbol	100 pin QFP100	64 pin QFP64	48 pin QFN48	Reset state [1]	Type	Function #	Description
					I/O	1	FC7_CTS_SDA_SSEL0 — Flexcomm 7: USART clear-to-send, I2C data I/O, SPI Slave Select 0.
						2	R — Reserved.
					O	3	CTIMER3_MAT2 — 32-bit CTimer3 match output 2.
						4	R — Reserved.
					I/O	5	FC4_RXD_SDA_MOSI_DATA — Flexcomm 4: USART receiver, I2C data I/O, SPI master-out/slave-in data, I2S data I/O.
						6	R — Reserved.
						7	R — Reserved.
						8	R — Reserved.
						9	R — Reserved.
						10	R — Reserved.
					I/O	11	PWM1_A0 — FlexPWM1 PWMA output 0.
					O	12	TRIGOUT_1 — Trigger Output to pins. Please refer to IOCON chapter.
						13	R — Reserved.
						14	R — Reserved.
						15	R — Reserved.
PIO1_22/HSCMP1_IN1/DAC0_OUT	40	25	-	[2]	Z	I/O	0 PIO1_22/HSCMP1_IN1/DAC0_OUT — General-purpose digital input/output pin. High-Speed Comparator 1 input 1. DAC0 output.
						1	R — Reserved.
						2	R — Reserved.
					O	3	CTIMER2_MAT3 — 32-bit CTimer2 match output 3.
					I	4	SCT0_GPI5 — Pin input 5 to SCTimer/PWM.
					I/O	5	FC4_SSEL3 — Flexcomm 4: SPI slave select 3.
						6	R — Reserved.
						7	R — Reserved.
						8	R — Reserved.
					I	9	CAN0_RD — Receiver input for CAN 0.
						10	R — Reserved.
					I/O	11	PWM0_B1 — FlexPWM0 PWMB output of SubModule1.
					O	12	TRIGOUT_2 — Trigger Output to pins. Please refer to IOCON chapter.
						13	R — Reserved.
						14	R — Reserved.

Table 3. Pin description ...continued

Symbol	100 pin QFP100	64 pin QFP64	48 pin QFN48	Reset state [1]	Type	Function #	Description
						15	R — Reserved.
PIO1_23/HSCMP2_IN1	49	-	-	[2]	Z	I/O	0 PIO1_23/HSCMP2_IN1 — General-purpose digital input/output pin. High-Speed Comparator 2 input 1.
						I/O	1 FC2_SCK — Flexcomm 2: USART, SPI, or I2S clock.
						O	2 SCT0_OUT0 — SCTimer/PWM output 0.
							3 R — Reserved.
							4 R — Reserved.
						I/O	5 FC3_SSEL2 — Flexcomm 3: SPI slave select 2.
							6 R — Reserved.
							7 R — Reserved.
							8 R — Reserved.
							9 R — Reserved.
							10 R — Reserved.
						I/O	11 PWM1_A1 — FlexPWM1 PWMA output 1
						O	12 TRIGOUT_4 — Trigger Output to pins. Please refer to IOCON chapter.
							13 R — Reserved.
							14 R — Reserved.
							15 R — Reserved.
PIO1_24/ADC1IN8B	3	-	-	[2]	Z	I/O	0 PIO1_24/ADC1IN8B — General-purpose digital input/output pin. Analog input channel 8B. Can optionally be paired with CH8A for differential input on ADC1 channel 8.
						I/O	1 FC2_RXD_SDA_MOSI_DATA — Flexcomm 2: USART receiver, I2C data I/O, SPI master-out/slave-in data, I2S data I/O.
						O	2 SCT0_OUT1 — SCTimer/PWM output 1.
							3 R — Reserved.
							4 R — Reserved.
						I/O	5 FC3_SSEL3 — Flexcomm 3: SPI slave select 3.
							6 R — Reserved.
							7 R — Reserved.
							8 R — Reserved.
							9 R — Reserved.
							10 R — Reserved.
							11 R — Reserved.
						O	12 AOI0_OUT2 — AND/OR/INVERT 0 Logic Output 2.

Table 3. Pin description ...continued

Symbol	100 pin QFP100	64 pin QFP64	48 pin QFN48	Reset state [1]	Type	Function #	Description
						13	R — Reserved.
						14	R — Reserved.
						15	R — Reserved.
PIO1_25	77	-	-	[2]	Z	I/O 0	PIO1_25 — General-purpose digital input/output pin.
						I/O 1	FC2_TXD_SCL_MISO_WS — Flexcomm 2: USART transmitter, I2C clock, SPI master-in/slave-out data I/O, I2S word-select/frame.
						O 2	SCT0_OUT2 — SCTimer/PWM output 2.
						3	R — Reserved.
						I 4	UTICK_CAP0 — Micro-tick timer capture input 0.
						5	R — Reserved.
						6	R — Reserved.
						7	R — Reserved.
						8	R — Reserved.
						9	R — Reserved.
						10	R — Reserved.
						I/O 11	PWM1_A2 — FlexPWM1 PWMA output 2.
						12	R — Reserved.
						O 13	AOI0_OUT3 — AND/OR/INVERT 0 Logic Output 3.
						14	R — Reserved.
						15	R — Reserved.
PIO1_26	68	-	-	[2]	Z	I/O 0	PIO1_26 — General-purpose digital input/output pin.
						I/O 1	FC2_CTS_SDA_SSEL0 — Flexcomm 2: USART clear-to-send, I2C data I/O, SPI Slave Select 0.
						O 2	SCT0_OUT3 — SCTimer/PWM output 3.
						I 3	CTIMER_INP3 — Capture input to CTIMER input multiplexers.
						I 4	UTICK_CAP1 — Micro-tick timer capture input 1.
						I/O 5	HS_SPI_SSEL3 — Slave Select 3 for high speed SPI.
						6	R — Reserved.
						7	R — Reserved.
						8	R — Reserved.
						9	R — Reserved.
						10	R — Reserved.
						I/O 11	PWM0_A1 — FlexPWM0 PWMA output 1.
						12	R — Reserved.

Table 3. Pin description ...continued

Symbol	100 pin QFP100	64 pin QFP64	48 pin QFN48	Reset state [1]	Type	Function #	Description
					O	13	AOI1_OUT2 — AND/OR/INVERT 1 Logic Output 2.
						14	R — Reserved.
						15	R — Reserved.
PIO1_27	86	-	-	[2]	Z	0	PIO1_27 — General-purpose digital input/output pin.
					I/O	1	FC2_RTS_SCL_SSEL1 — Flexcomm 2: USART request-to-send, I2C clock, SPI slave select 1.
						2	R — Reserved.
					O	3	CTIMER0_MAT3 — 32-bit CTimer0 match output 3.
					O	4	CLKOUT — Output of the CLKOUT function.
						5	R — Reserved.
						6	R — Reserved.
						7	R — Reserved.
					I/O	8	FLEXSPI0_DATA6 — Data bit 6 for the FlexSPI interface.
					O	9	CAN0_TD — Transmitter output for CAN 0.
						10	R — Reserved.
					I/O	11	PWM1_B2 — FlexPWM1 PWMB output of SubModule2.
						12	R — Reserved.
						13	R — Reserved.
						14	R — Reserved.
						15	R — Reserved.
PIO1_28	72	-	-	[2]	Z	0	PIO1_28 — General-purpose digital input/output pin.
					I/O	1	FC7_SCK — Flexcomm 7: USART, SPI, or I2S clock.
					I/O	2	R — Reserved.
					I	3	CTIMER_INP2 — Capture input to CTIMER input multiplexers.
						4	R — Reserved.
						5	R — Reserved.
						6	R — Reserved.
						7	R — Reserved.
						8	R — Reserved.
						9	R — Reserved.
					O	10	TRIGOUT_4 — Trigger Output to pins. Please refer to IOCON chapter.
					I/O	11	PWM1_X3 — FlexPWM1 PWMX output 3.
						12	R — Reserved.

Table 3. Pin description ...continued

Symbol	100 pin QFP100	64 pin QFP64	48 pin QFN48	Reset state [1]	Type	Function #	Description
					O	13	HSCMP1_OUT — High-Speed Comparator 1 Output.
						14	R — Reserved.
						15	R — Reserved.
PIO1_29	80	-	-	[2][8]	Z	I/O	PIO1_29 — General-purpose digital input/output pin.
					I/O	1	FC7_RXD_SDA_MOSI_DATA — Flexcomm 7: USART receiver, I2C data I/O, SPI master-out/slave-in data, I2S data I/O.
						2	R — Reserved.
					I	3	SCT0_GPI6 — Pin input 6 to SCTimer/PWM.
						4	R — Reserved.
						5	R — Reserved.
						6	R — Reserved.
						7	R — Reserved.
					I/O	8	FLEXSPI0_DATA7 — Data bit 7 for the FlexSPI interface.
						9	R — Reserved.
						10	R — Reserved.
					I/O	11	PWM0_X2 — FlexPWM0 PWMX output 2.
						12	R — Reserved.
					I	13	EXTTRIG_IN9 — Input Mux. Trigger input to selected on-chip peripherals. Please refer to INPUT MUX chapter.
						14	R — Reserved.
						15	R — Reserved.
PIO1_30/ WAKEUP3	65	-	-	[2]	Z	I/O	PIO1_30/WAKEUP3 — General-purpose digital input/output pin. This pin can trigger a wake-up from deep power-down mode. WAKEUP pin can be configured as rising or falling edge.
					I/O	1	FC7_TXD_SCL_MISO_WS — Flexcomm 7: USART transmitter, I2C clock, SPI master-in/slave-out data I/O, I2S word-select/frame.
						2	R — Reserved.
					I	3	SCT0_GPI7 — Pin input 7 to SCTimer/PWM.
						4	R — Reserved.
						5	R — Reserved.
						6	R — Reserved.
						7	R — Reserved.
						8	R — Reserved.

Table 3. Pin description ...continued

Symbol	100 pin QFP100	64 pin QFP64	48 pin QFN48	Reset state [1]	Type	Function #	Description
						9	R — Reserved.
						10	R — Reserved.
					I/O	11	PWM0_X3 — FlexPWM0 PWMX output 3.
					O	12	AOI1_OUT3 — AND/OR/INVERT 1 Logic Output 3.
					O	13	HSCMP0_OUT — High-Speed Comparator Output 0.
						14	R — Reserved.
						15	R — Reserved.
PIO1_31	92	-	-	[2]	Z	I/O	0 PIO1_31 — General-purpose digital input/output pin.
					I/O	1	MCLK — MCLK input or output for I2S.
					O	2	R — Reserved.
					O	3	CTIMER0_MAT2 — 32-bit CTimer0 match output 2.
					O	4	SCT0_OUT6 — SCTimer/PWM output 6.
						5	R — Reserved.
						6	R — Reserved.
					I	7	USB0_VBUS — Monitors the presence of USB0 bus power.
						8	R — Reserved.
						9	R — Reserved.
						10	R — Reserved.
					I/O	11	PWM1_B2 — FlexPWM1 PWMB output of SubModule2.
						12	R — Reserved.
					I	13	EXTTRIG_IN2 — Input Mux. Trigger input to selected on-chip peripherals. Please refer to INPUT MUX chapter.
						14	R — Reserved.
						15	R — Reserved.
PIO2_0/ ADC0IN9A	24	-	-	[2]	Z	I/O	0 PIO2_0/ADC0IN9A — General-purpose digital input/output pin. Analog input channel 9A. Can optionally be paired with CH9B for differential input on ADC0 channel 9.
						1	R — Reserved.
					I/O	2	FC0_RXD_SDA_MOSI_DATA — Flexcomm 0: USART receiver, I2C data I/O, SPI master-out/slave-in data, I2S data I/O.
						3	R — Reserved.
					I	4	CTIMER_INP4 — Capture input to CTIMER input multiplexers.

Table 3. Pin description ...continued

Symbol	100 pin QFP100	64 pin QFP64	48 pin QFN48	Reset state [1]	Type	Function #	Description
					I	5	I3C0_PUR — Pullup resistor control for I3C master. The I3C0_PUR function controls the SDA pull-up. It is intended to be connected to one end of an external low-value pull-up resistor (e.g., 1KOhm), with the other end connected to the SDA line. If there is no external high weak bus keeper on SDA, then add an additional external weak (e.g., 100KR or even 500KR) always-on pull-up on this line.
						6	R — Reserved.
						7	R — Reserved.
						8	R — Reserved.
						9	R — Reserved.
						10	R — Reserved.
						11	R — Reserved.
					O	12	AOIO_OUT0 — AND/OR/INVERT 0 Logic Output 0.
						13	R — Reserved.
						14	R — Reserved.
						15	R — Reserved.
PIO2_1/ OPAMP2_INP	1	1	48	[2]	Z	I/O	PIO2_1/OPAMP2_INP — General-purpose digital input/output pin. Op Amp 2 positive input.
						1	R — Reserved.
						I/O	FC0_TXD_SCL_MISO_WS — Flexcomm 0: USART transmitter, I2C clock, SPI master-in/slave-out data I/O, I2S word select/frame.
						3	R — Reserved.
					O	4	CTIMER1_MAT0 — 32-bit CTimer1 match output 0.
					I/O	5	I3C0_SDA — Data for I3C master or slave.
						6	R — Reserved.
						7	R — Reserved.
						8	R — Reserved.
						9	R — Reserved.
						10	R — Reserved.
						11	R — Reserved.
					O	12	AOIO_OUT2 — AND/OR/INVERT 0 Logic Output 2.
						13	R — Reserved.
						14	R — Reserved.
						15	R — Reserved.
LX	46	31	23	-	-		DC-DC converter power stage output.

Table 3. Pin description ...continued

Symbol	100 pin QFP100	64 pin QFP64	48 pin QFN48		Reset state [1]	Type	Function #	Description
RESETN	34	23	17	[5]	-	I		External reset input: A LOW on this pin resets the device, causing I/O ports and peripherals to take on their default states, and the boot code to execute. Wakes up the part from deep power-down mode.
USB0_3V3	97	-	-		-	-		USB0 analog 3.3 V supply.
USB0_DM	99	-	-	[6][8]		I/O		USB0 bidirectional D- line.
USB0_DP	98	-	-	[6][8]		I/O		USB0 bidirectional D+ line.
USB0_VSS	10 0	-	-					USB0 analog 3.3 V ground.
VDD_MAIN	48	32	24	[9]	-	-		Power control system.
VDD_MAIN_PWR	47	32	24	[9]	-	-		High current/High transient current.
VBAT	53	35	25	[9]	-	-		Battery Supply.
VDDA	13	8	6		-	-		Analog supply voltage. At PCB level, has to be tied to main supply (VDD_MAIN)
VREFN/ADC1IN5B/ ADC0IN5B	16	11	9		-	-		ADC negative reference voltage. On the HVQFN48, VREFN is internally tied to the VSSA pin. Analog input channel 5B. Can optionally be paired with CH5A for differential input on ADC1 channel 5. Analog input channel 5B. Can optionally be paired with CH5A for differential input on ADC0 channel 5
VREFP	15	10	8		-	-		ADC positive reference voltage.
XTAL32K_N	52	34	-	[10]	-	-		RTC oscillator output.
XTAL32K_P	51	33	-	[10]	-	-		RTC oscillator input.
XTAL32M_N	32	21	-	[7]	-	-		Main oscillator output.
XTAL32M_P	33	22	-	[7]	-	-		Main oscillator input.
OPAMP0_INN	27	18	14					Op Amp 0 negative input.
OPAMP1_INN	29	20	16					Op Amp 1 negative input.
OPAMP2_INN	2	2	1					Op Amp 2 negative input.
DAC0_OUT/ADC1IN4A/ ADC0IN4A/HSCMP0_IN5	31		-					DAC0 output. Analog input channel 4A. Can optionally be paired with CH4B for differential input on ADC1 channel 4. Analog input channel 4A. Can optionally be paired with CH4B for differential input on ADC0 channel 4. High-Speed Comparator 0, input 5.
ADC1IN1B	7	5	-					Analog input channel 1B. Can optionally be paired with CH1A for differential input on ADC1 channel 1.
ADC1IN1A	8	6	-					Analog input channel 1A. Can optionally be paired with CH1B for differential input on ADC1 channel 1.

Table 3. Pin description ...continued

Symbol	100 pin QFP100	64 pin QFP64	48 pin QFN48	Reset state ^[1]	Type	Function #	Description
VREF_OUT/ADC1IN5A/ ADC0IN5A	14	9	7				Output of the on-chip precision voltage reference from the VREG module. Can be 1.0 to 2.1V in 100mV steps. External capacitor (220 nF) is required. Analog input channel 5A. Can optionally be paired with CH5B for differential input on ADC1 channel 5. Analog input channel 5A. Can optionally be paired with CH5B for differential input on ADC0 channel 5
VSS	exposed pad						Ground for IOs
VSSA	17, 18	12	9				Analog ground. On the HVQFN48, ADC negative reference voltage.
VSS_MAIN_PWR	44	29	22				Star ground connection is managed to PCB ground plane.
VSS_MAIN	45	30	22				Star ground connection is managed to PCB ground plane.
VDDA	13	8	6				Analog supply voltage. At PCB level, has to be tied to main supply (VDD_MAIN).
VDD_CORE	38	24	18				Supply of DC-DC output stage. DC-DC core supply (references and regulation stages).
VDDIO_1	12, 43	8, 28	21, 5				Supply of Digital/Analog I/Os. Must be equal to VDD_MAIN.
VDDIO_2	63, 74, 85, 96	44, 56, 64	41				Supply of Digital I/Os/Analog I/Os. For Digital functions, voltage can be less than or equal to VDD_MAIN. For Analog functions, voltage must be equal to VDD_MAIN.

- [1] PU = input mode, pull-up enabled (pull-up resistor pulls pin up towards V_{DD}). PD = input mode, pull-down enabled (pull-down resistor pulls pin down towards V_{SS}). Z = high impedance; pull-up, pull-down, and input disabled. AI = analog input. I = input. O = output. I/O = input/output. Reset state reflects the pin state at reset without boot code operation. For termination on unused pins, see [Section 6.1.2 "Termination of unused pins"](#).
- [2] Pad with programmable glitch filter; provides digital I/O functions with TTL levels and hysteresis; normal drive strength. Pulse width of spikes or glitches suppressed by input filter is from 3 ns to 16 ns (simulated value).
- [3] True open-drain pin. I2C-bus pins compliant with the I2C-bus specification for I2C standard mode, I2C Fast-mode, and I2C Fast-mode Plus. The pin requires an external pull-up to provide output functionality. When power is switched off, this pin is floating and does not disturb the I2C lines. Open-drain configuration applies to all functions on this pin.
- [4] Pin providing standard digital I/O functions with configurable modes, configurable hysteresis, and analog input. When configured as an analog input, the digital section of the pin is disabled.
- [5] Reset pad with glitch filter and hysteresis. Pulse width of spikes or glitches suppressed by input filter is from 3 ns to 20 ns (simulated value)
- [6] Transparent analog pad.
- [7] Optional bypass mode is supported, xtal32M_P can be driven by an external clock with restrictions in terms of drive level. See: [Section 13. "Application information"](#).
- [8] The corresponding VBUS must be connected to supply voltage when using the USB peripheral. USB0_VBUS is not 5V tolerant.
- [9] Main battery supply: Star connection at application level (PCB).

[10] Optional bypass mode is supported, xtal32K_P can be driven by an external clock with restrictions in terms of drive level See: [Section 13. "Application information"](#).

6.1.1 Power Supply for pins

[Table 4](#) shows the GPIOs belonging to the specific VDDIO groups domain. VDDIO_1 must be equal to VDD_MAIN. VDDIO_2 can be less than or equal to VDD_MAIN.

Table 4. Power Supply for pins

Pin	GPIO pins
VDDIO_1	PIO0_1 PIO0_7 to PIO0_8 PIO0_10 to PIO0_12 PIO0_15 to PIO0_17 PIO0_23 PIO0_27 PIO0_31 PIO1_0 PIO1_5 to PIO1_10 PIO1_19 to PIO1_24 PIO2_0 to PIO2_1 RESETN
VDDIO_2	P0_0 P0_2 to P0_6 P0_9 P0_13 to P0_14 P0_18 to P0_22 P0_24 to P0_26 P0_28 to P0_30 P1_1 to P1_4 P1_11 to P1_18 P1_25 to P1_31

6.1.2 Termination of unused pins

[Table 5](#) shows how to terminate pins that are **not** used in the application. In many cases, unused pins should be connected externally or configured correctly by software to minimize the overall power consumption of the part.

Unused pins with GPIO function should be configured as outputs set to LOW with their internal pull-up disabled. To configure a GPIO pin as output and drive it LOW, select the GPIO function in the IOCON register, select output in the GPIO DIR register, and write a 0 to the GPIO PORT register for that pin. Disable the pull-up in the pin's IOCON register.

In addition, it is recommended to configure all GPIO pins that are not bonded out on smaller packages as outputs driven LOW with their internal pull-up disabled.

Table 5. Termination of unused pins

Pin	Default state ^[1]	Recommended termination of unused pins
RESET	I; PU	The RESET pin can be left unconnected if the application does not use it.
all PION_m (not open-drain)	I; PU	Can be left unconnected if driven LOW and configured as GPIO output with pull-up or pull-down disabled by software.
PION_m (I2C open-drain)	IA	Can be left unconnected if driven LOW and configured as GPIO output by software.
XTAL32K_P	-	Connect to ground. When grounded, the RTC oscillator is disabled.
XTAL32K_N	-	Can be left unconnected.
XTAL32M_P	-	Connect to ground. When grounded, the RTC oscillator is disabled.
XTAL32M_N	-	Can be left unconnected.
VREFP	-	Tie to VDD_MAIN.
VREFN	-	Tie to VSS.
VDDA	-	Tie to VDD_MAIN.
VSSA	-	Tie to VSS.
USBn_DP	F	Can be left unconnected.
USBn_DM	F	Can be left unconnected.
USBn_3V3	F	Tie to VDD_MAIN. If not using USB and using 1.8 V supply, USBn_3V3 can be connected to 1.8 V.
USBn_VSS	F	Tie to VSS.
USB0_VBUS	F	Tie to VDD_MAIN.

[1] I = Input, IA = Inactive (no pull-up/pull-down enabled), PU = Pull-Up enabled

6.1.3 Using Internal DC-DC converter

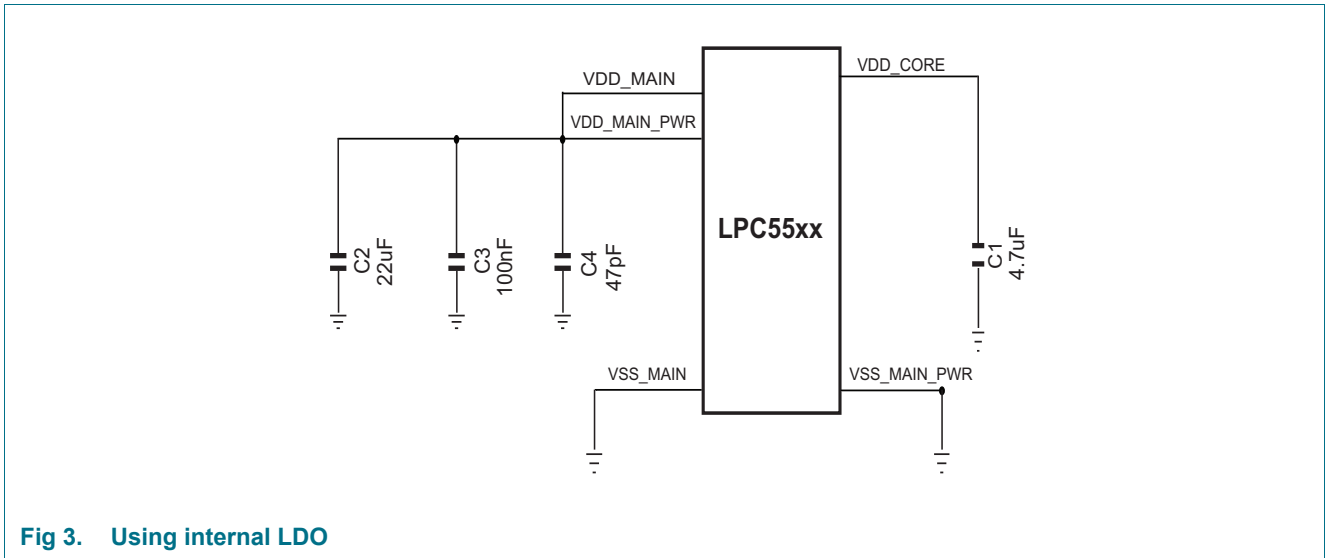

Fig 3. Using internal LDO

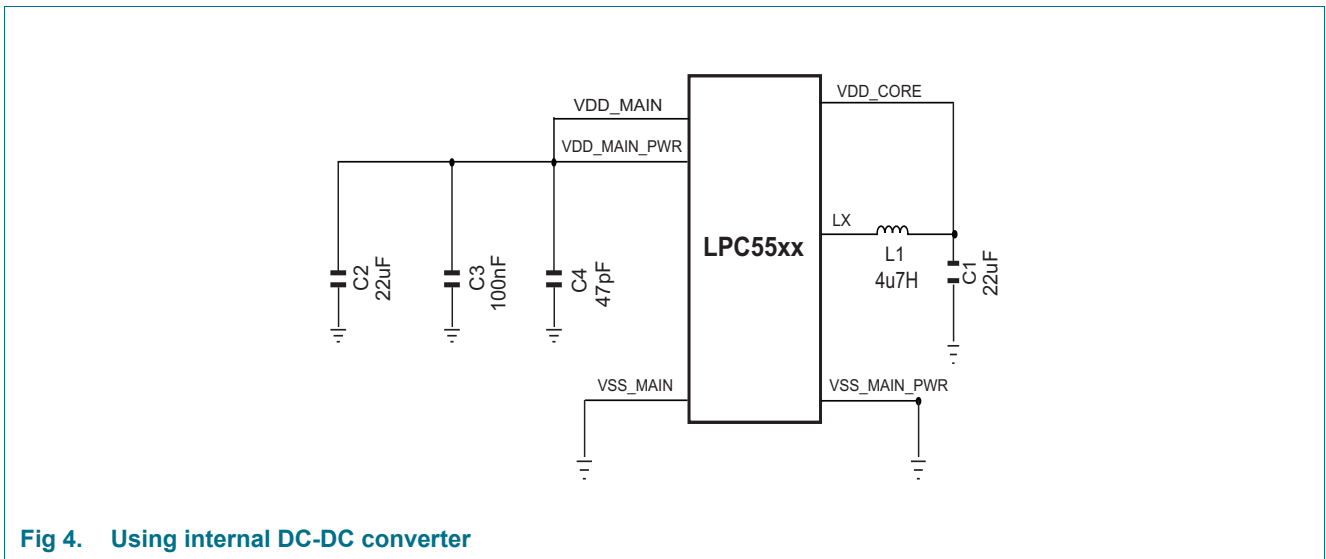

Fig 4. Using internal DC-DC converter

7. Functional description

7.1 Architectural overview

The Arm Cortex M33 includes two AHB-Lite buses, one system bus and one code bus. The Code AHB (C-AHB) interface is used for any instruction fetch and data access to the Code region of the ARMv8-M memory map ([0x00000000 - 0x1FFFFFFF]). The System AHB (S-AHB) interface is used for instruction fetch and data access to all other regions of the ARMv8-M memory map ([0x20000000 - 0xFFFFFFFF]).

The chip uses a multi-layer AHB matrix to connect the ARM Cortex-M33 buses and other bus masters to peripherals in a flexible manner that optimizes performance by allowing peripherals that are on different slave ports of the matrix to be accessed simultaneously by different bus masters. [Section 5. "Block diagram"](#) shows details of the available matrix connections.

7.2 Arm Cortex-M33 processor

The ARM Cortex-M33 is based on the ARMv8-M architecture that offers systems enhancements, such as ARM TrustZone® security, single-cycle digital signal processing, low power consumption, enhanced debug features, and a high level of support block integration. The ARM Cortex-M33 CPU employs a 3-stage instruction pipe and includes an internal prefetch unit that supports speculative branching. A hardware floating-point processor is integrated into the core. On the chip, the Cortex-M33 is augmented with two hardware co-processors providing accelerated support for additional DSP algorithms and cryptography.

The Arm Cortex M33 provides a security foundation, offering isolation to protect valuable IP and data with TrustZone technology. It simplifies the design and software development of digital signal control systems with the integrated digital signal processing (DSP) instructions.

7.3 Arm Cortex-M33 integrated Floating Point Unit (FPU)

The FPU fully supports single-precision add, subtract, multiply, divide, multiply and accumulate, and square root operations. It also provides conversions between fixed-point and floating-point data formats, and floating-point constant instructions.

The FPU provides floating-point computation functionality that is compliant with the ANSI/IEEE Std 754-2008, IEEE Standard for Binary Floating-Point Arithmetic, referred to as the IEEE 754 standard.

7.4 Memory Protection Unit (MPU)

The Cortex-M33 processor includes a Memory Protection Unit (MPU). The MPU provides fine grain memory control, enabling applications to implement security privilege levels, separating code, data, and stack on a task-by-task basis.

The MPU allows separating processing tasks by disabling access to memory regions, allowing memory regions to be defined as read-only, and detecting unexpected memory accesses.

The MPU separates the memory into distinct regions and implements protection by preventing disallowed accesses. The MPU supports up to eight regions each of which can be divided into eight subregions. Accesses to memory locations that are not defined in the MPU regions, or not permitted by the region's setting cause a Memory Management Fault exception.

The MPU register interface is located on the CPU private peripheral bus and is described in detail in Ref 1 "Cortex-M33 DEBUG".

7.5 Nested Vectored Interrupt Controller (NVIC) for Cortex-M33

The NVIC is an integral part of the Cortex-M33. The tight coupling to the CPU allows for low interrupt latency and efficient processing of late arriving interrupts.

7.5.1 Features

- Controls system exceptions and peripheral interrupts.
- 118 vectored interrupts.
- Eight programmable interrupt priority levels, with hardware priority level masking.
- Relocatable vector table using Vector Table Offset Register (VTOR).
- Non-Maskable Interrupt (NMI).
- Software interrupt generation.

7.5.2 Interrupt sources

Each peripheral device has one interrupt line connected to the NVIC but may have several interrupt flags.

7.6 System Tick timer (SysTick)

The ARM Cortex-M33 core include a system tick timer (SysTick) that is intended to generate a dedicated SYSTICK exception. The clock source for the SysTick can be the system clock or the SYSTICK clock.

7.7 PowerQuad Hardware Accelerator

The chip has a PowerQuad hardware accelerator for CMSIS DSP functions (fixed and floating point unit) with support of SDK software API faster execution of ARM CMSIS instruction set. The PowerQuad is a hardware accelerator targeting common calculations in DSP applications. With the assistance of the PowerQuad, the Cortex-M33 can be freed to perform other tasks. While the PowerQuad is executing the assigned computation task, the CM33 can prepare the next PowerQuad task, resulting in a pipeline of PowerQuad tasks.

7.8 On-chip static RAM

The chip supports up to 128 kB SRAM with separate bus master access for higher throughput and individual power control for low-power operation.

Parity support on all RAM banks except RAM1 bank. ECC support available only on RAM1 bank.

7.8.1 RAM partitions

Table 6. RAM Partition Table (Non-secure)

Type Number	Total SRAM (KB) (RAMX + RAM0 + RAM1 + RAM3 + RAM4)	RAMX (16 KB)	RAM0 (4x4 KB)	RAM1 (1x16 KB)	RAM2 (1x32 KB)	RAM3 (1x32 KB)	RAM4 (4x4 KB)
LPC5534	96	16	16	16	32	-	16
LPC5536	128	16	16	16	32	32	16

Remark:

RAM0 has 4 banks - RAM_00, RAM_01, RAM_02, RAM_03. In Power-down mode, RAM_00 is reserved for CPU state retention.

RAM_01 can be used for stack.

RAM1 has 1 bank - RAM_10.

RAM2 has 1 bank - RAM_20.

RAM3 has 1 bank - RAM_30.

RAM4 has 4 banks - RAM_40, RAM_41, RAM_42, RAM_43. RAM4 is dedicated for PowerQuad use. If PowerQuad is not used,

RAM4 can be used for general purpose.

Please refer to the Reference Manual (memory map) for further details.

7.9 On-chip flash

The chip supports up to 256 kB of on-chip flash memory.

Remark: The last 18 pages (10 KB) are reserved on the 256 KB flash devices resulting in 246 KB internal flash memory.

7.10 On-chip ROM

The on-chip ROM contains the bootloader and the following features:

- Booting of images from on-chip flash
- Supports CRC32 image integrity checking.
- Supports flash programming through In System Programming (ISP) commands over following interfaces: USB0 interfaces using HID Class device, UART interface (Flexcomm 0) with auto baud, High-speed SPI slave interfaces using mode 3 (CPOL = 1 and CPHA = 1), I2C slave interface (Flexcomm 1), and CAN-FD ISP.
- ROM API functions:
Flash programming API, Power control API, OTP eFuse programming API
- Support dual images (boot latest version) from on-chip flash using re-map feature.
- Support loading image to RAM from external Octal/QuadSPI device.
- Support booting XIP images present on Octal/QuadSPI devices.
- Support dual Execute-in-Place (XIP) images in Octal/QSPI flash through flash address remap feature.
- Support load-to-RAM boot mode from 1-bit SPI flash devices connected to Flexcomm (selectable by PFR) as normal boot option and recovery boot option.
- USB Device DFU Connection (Device only).
- Code Read protection (CRP) on non-secure devices.
- Crystal-less USB ISP mode.

7.10.1 FlexSPI Flash Interface

The Flexible Serial Peripheral Interface (FlexSPI) host controller supports one port and up to 2 external devices. FlexSPI supports Single/Dual/Quad/Octal mode data transfer (1/2/4/8 bidirectional data lines).

FlexSPI flash interface with 8 KB cache with CACHE64 controller for execute-in-place and supports DMA.

Remark: HVQFN 48 pin package devices support FlexSPI boot only in Quad mode (4 data pins) flash devices. Due to no availability of upper data pins, Hyperflash and Octal mode flash devices are not supported.

7.10.1.1 Features

- FlexSPI complies with JEDEC's JESD151 v1.0 for xSPI standard specification.
- Flexible sequence engine (LUT table) to support various vendor devices.
 - Serial NOR Flash: XccelaFlash, HyperFlash, EcoXiP Flash, Octa Flash, and all QSPI flash devices
 - Serial NAND Flash
 - Serial pSRAM: HyperRAM, Xccela RAM (IoTRAM)
 - FPGA device
- Flash access mode
 - Single/Dual/Quad/Octal mode
 - SDR/DDR mode
 - Individual/Parallel mode
- Support sampling clock mode:
 - Internal dummy read strobe looped back internally
 - Internal dummy read strobe looped back from pad
 - Flash provided read strobe
- Automatic Data Learning to select correct sample clock phase
- Memory mapped read/write access by AHB Bus
 - AHB RX Buffer implemented to reduce read latency. Total AHB RX Buffer size: 256 * 64 Bits
 - 16 AHB masters supported with priority for read access
 - 8 flexible and configurable buffers in AHB RX Buffer
 - AHB TX Buffer implemented to buffer all write data from one AHB burst. AHB TX Buffer size: 8 * 64 Bits
 - All AHB masters share this AHB TX Buffer. No AHB master number limitation for Write Access.
- Software triggered Flash read/write access by IP Bus
 - IP RX FIFO implemented to buffer all read data from External device. FIFO size: 64 * 64 Bits
 - IP TX FIFO implemented to buffer all Write data to External device. FIFO size: 128 * 64 Bits

- DMA support to fill IP TX FIFO
- DMA support to read IP RX FIFO
- SCLK stopped when reading flash data and IP RX FIFO is full
- SCLK stopped when writing flash data and IP TX FIFO is empty

7.11 Protected Flash Region (PFR)

The protected flash region is available to configure read UUID and user-defined fields available for specific data storage.

7.12 OTP eFuse

The One Time Programmable Memory (OTP) is used for device configuration. An additional 6 bytes of OTP memory is available for user application. The OTP eFuse also contains pre-programmed factory configuration data such as on-chip oscillator calibration values, among other things. It may also be used by customer applications to configure some details of device operation, and enforce ECDSA signature check aspects of device.

7.13 Memory mapping

Please refer to the Reference Manual for memory map overview and descriptions.

7.14 AHB multilayer matrix

The device uses a multi-layer AHB matrix to connect the CPU buses and other bus masters to peripherals in a flexible manner that optimizes performance by allowing peripherals that are on different slave ports of the matrix to be accessed simultaneously by different bus masters. The device block diagram in [Section 5. "Block diagram"](#) shows details of the available matrix connections.

7.15 System control

7.15.1 Clock sources

The device supports 2 external and 3 internal clock sources:

- **Internal Free Running Oscillator (FRO).** This oscillator provides a selectable 96 MHz output, and a 12 MHz output (divided down from the selected higher frequency) that can be used as a system clock. The FRO is trimmed to +/- 1% accuracy over the entire voltage and 0 C to 85 C. The FRO is trimmed to +/- 2% accuracy over the entire voltage and -40 C to 105 C. The FRO 12 MHz oscillator provides the default clock at reset and provides a clean system clock shortly after the supply pins reach operating voltage.
On power-up, the chip boots up using FRO high-speed output at 96 MHz.
- **32 kHz Internal Free Running Oscillator FRO.** The FRO is trimmed to +/- 2% accuracy over the entire voltage and temperature range.
- **Internal low power oscillator (FRO 1 MHz).** The FRO is trimmed to +/- 15% accuracy over the entire voltage and temperature range.
- **Crystal oscillator with an operating frequency of 12 MHz to 25 MHz.** Option for external clock input (bypass mode) for clock frequencies of up to 25 MHz
- **Crystal oscillator with 32.768 kHz operating frequency.**

Each crystal oscillator has one embedded capacitor bank, where each can be used as an integrated load capacitor for the crystal oscillators. Using APIs, the capacitor banks on each crystal pin can tune the frequency for crystals with a Capacitive Load (CL) leading to conserving board space and reducing costs. See: [Section 13. "Application information"](#).

7.15.2 PLL (PLL0 and PLL1)

PLL0 and PLL1 allows CPU operation up to the maximum CPU rate without the need for a high-frequency external clock. PLL0 and PLL1 can run from the internal FRO 12 MHz output, the external oscillator, internal FRO 1 MHz output, or the 32.768 kHz RTC oscillator.

The system PLL accepts an input clock frequency in the range of 2 kHz - 150 MHz. The input frequency is multiplied up to a high frequency with a Current Controlled Oscillator (CCO). The PLL can be enabled or disabled by software.

7.15.3 Clock generation

The system control block facilitates the clock generation. Many clocking variations are possible. [Figure 5](#) gives an overview of potential clock options. [Figure 7](#) describes signals on the clocking diagram. The maximum clock frequency is 150 MHz.

Remark: The indicated clock multiplexers shown in [Figure 5](#) are synchronized. In order to operate, the currently selected clock must be running, and the clock to be switched to must also be running. This is so that the multiplexer can gracefully switch between the two clocks without glitches. Other clock multiplexers are not synchronized. The output divider can be stopped and restarted gracefully during switching if a glitch-free output is needed.

The low-power oscillator provides a frequency in the range of 1 MHz. The accuracy of this clock is limited to +/- 15% over temperature, voltage, and silicon processing variations after trimming made during assembly. To determine the actual watchdog oscillator output, use the frequency measure block.

The part contains one system PLL that can be configured to use a number of clock inputs and produce an output clock in the range of 1.2 MHz up to the maximum chip frequency, and can be used to run most on-chip functions. The output of the PLL can be monitored through the CLKOUT pin.

For 1.8 V operation CLKOUT limitation is 50 MHz (SLEW rate setting = 1) and for 3.3 V operation, limitation is 90 MHz (SLEW rate setting = 1).

Table 7. Clocking diagram signal name descriptions

Name	Description
32k_osc	The 32 kHz output of the RTC oscillator. The 32 kHz clock must be enabled in the RTCOSCCTRL register.
clk_in	This is the internal clock that comes from the external oscillator.
frg_clk	The output of each Fractional Rate Generator to Flexcomm clock. Each FRG and its source selection is shown in Figure 5 .
fro_12m	12 MHz divided down from the currently selected on-chip FRO oscillator.
fro_hf	The currently selected FRO high speed output at 96 MHz.
main_clk	The main clock used by the CPU and AHB bus, and potentially many others. The main clock and its source selection are shown in Figure 5 .
mclk_in	The MCLK input function, when it is connected to a pin by selecting it in the IOCON block.
pll0_clk	The output of the PLL0. The PLL0 and its source selection is shown in Figure 5 .

Table 7. Clocking diagram signal name descriptions

Name	Description
pll1_clk	The output of the PLL1. The PLL1 and its source selection is shown in Figure 5 .
fro_1m	The output of the low power oscillator.
"none"	A tied-off source that should be selected to save power when the output of the related multiplexer is not used.

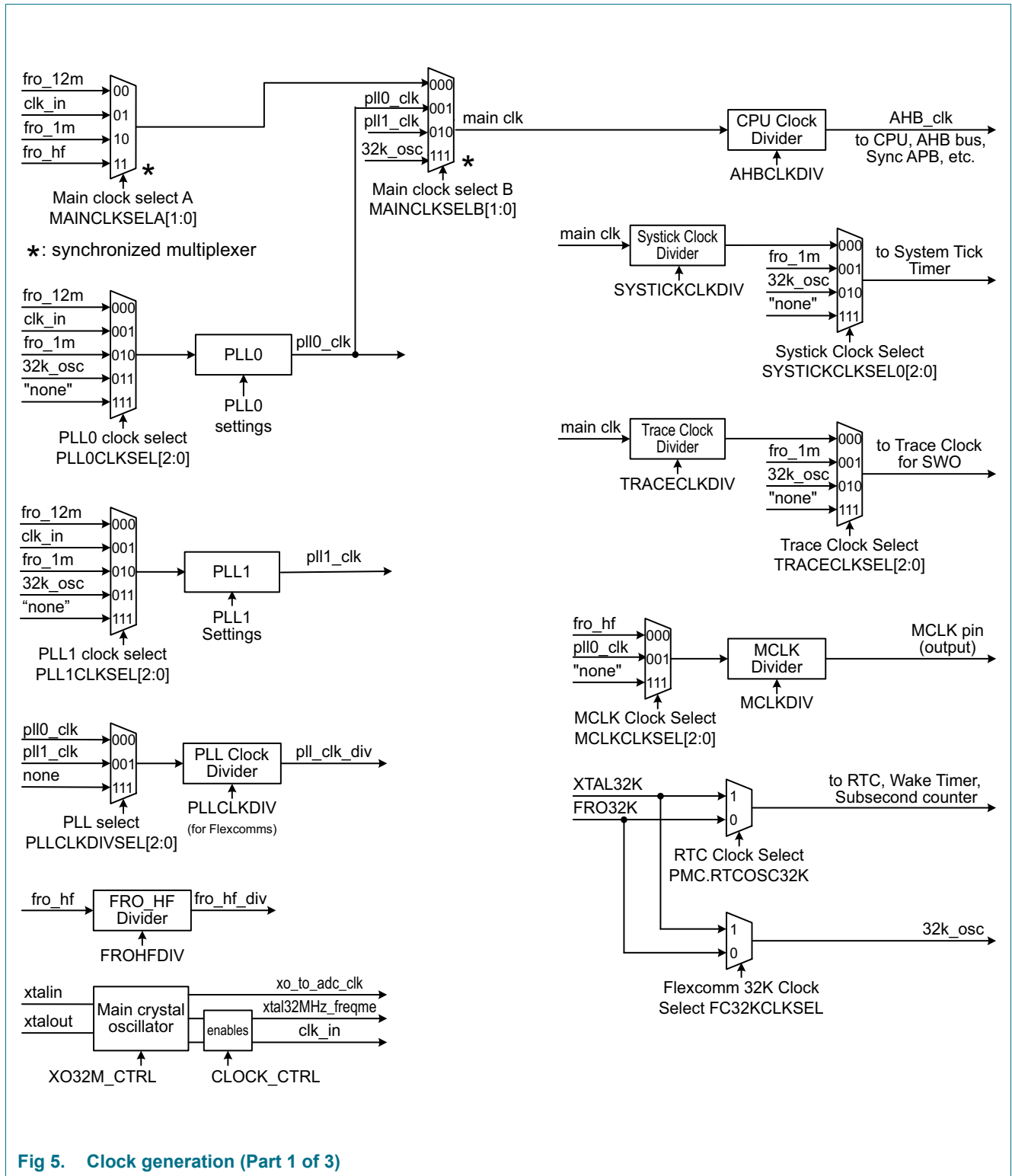

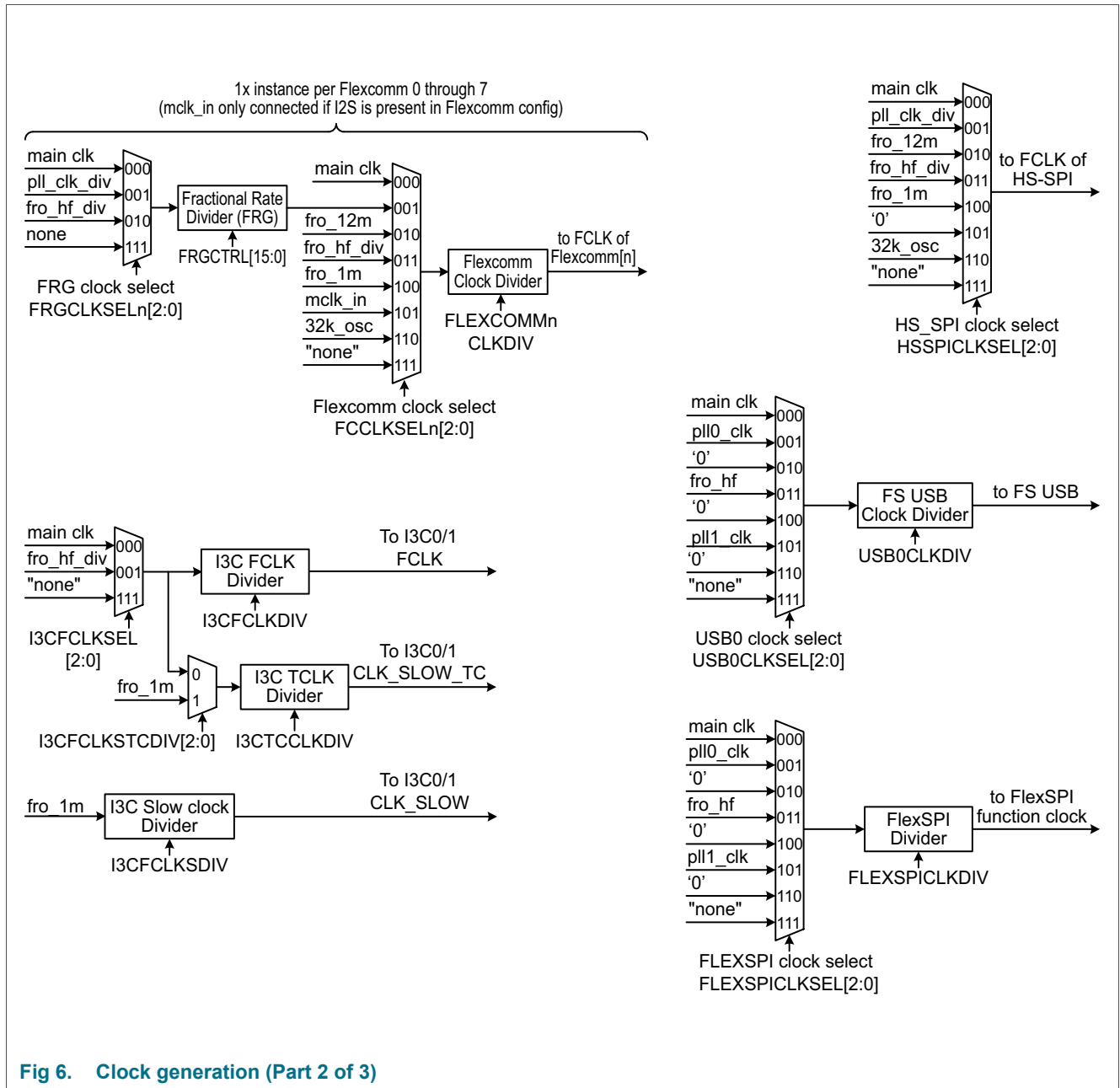

Fig 6. Clock generation (Part 2 of 3)

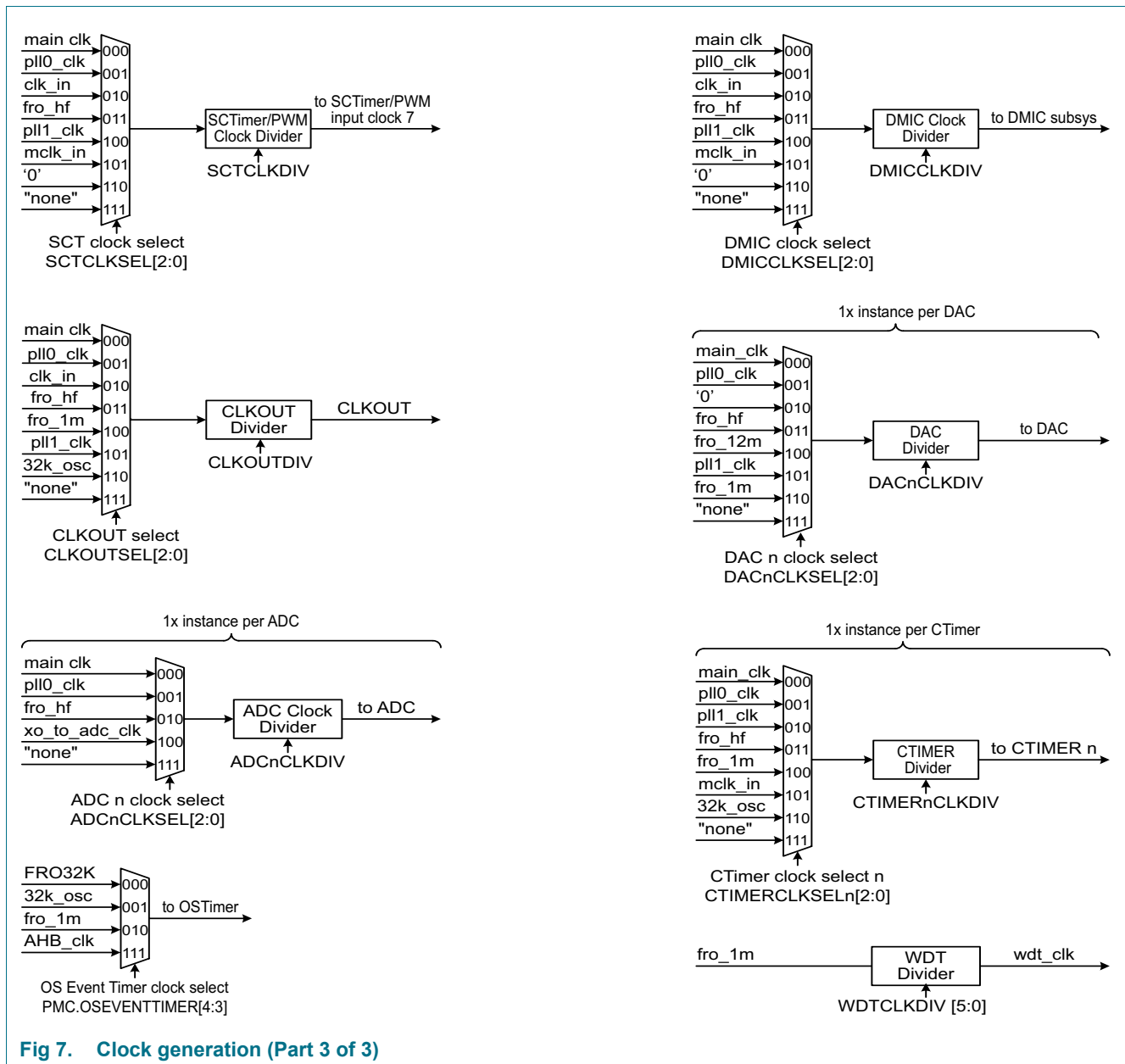

Fig 7. Clock generation (Part 3 of 3)

7.15.4 Brownout detection

The chip includes two Brown-out detectors to monitor the voltage of VDD_MAIN and VDD_CORE. If the voltage falls below one of the selected voltages, the BOD asserts an interrupt to the NVIC or issues a reset.

7.16 Power control

The chip supports a variety of power control features. In Active mode, when the chip is running, power and clocks to selected peripherals can be adjusted for power consumption. In addition, there are four special modes of processor power reduction with different peripherals running: sleep mode, deep-sleep mode, power-down mode, and deep power-down mode which can be activated by the power mode configure API.

7.16.1 DC-DC Buck Converter and Low Drop-Out (LDO)

The chip has an internal DC-DC Buck Converter and an internal Low Drop-Out (LDO) regulator where either can be selected as a supply source to the Core Logic and System Power domains. Both on-chip regulators convert input supply voltage (ranging from 1.8 V to 3.6 V via VDD_MAIN pin) to a fixed output voltage. The optimum internal output voltage is automatically set up when calling the POWER_SetVoltageForFrequency API function. To switch between the DC-DC and the LDO_CORE use the POWER_SetCorePowerSource power API function.

7.16.2 Sleep mode

In Sleep mode, the system clock to the CPU is stopped and execution of instructions is suspended until either a reset or interrupt occurs. Peripheral functions, if selected to be clocked can continue operation during Sleep mode and may generate interrupts to cause the processor to resume execution. Sleep mode eliminates dynamic power used by the processor itself, memory systems and related controllers, internal buses, and unused peripherals.

7.16.3 Deep-sleep mode

In Deep-sleep mode, the flash is powered down. The system clock to the CPU is stopped and if not configured, the peripherals receives no clocks. Through the power profiles API, selected peripherals such as USB0, Flexcomm interfaces 0 to 7 (SPI, I2C, USART, I2S), Flexcomm interface 8 (High Speed SPI), Micro-tick, WWDT, RTC, OSTimer, Standard Timers, comparator, and BOD can be left running in Deep-sleep mode. Clock sources such as FRO 12 MHz, FRO 32 kHz, FRO 1 MHz, the 32.768 kHz RTC clock, and the external oscillator can be enabled or disabled via software.

The chip can wake up from Deep-sleep mode via a reset, digital pins selected as inputs to the pin interrupt block and group interrupt block, OS Timer, Standard Timers, Micro-tick, RTC alarm, a watchdog timer interrupt/reset, BOD interrupt/reset, an interrupt from the USB0, SPI, I2C, I2S, USART, and comparator. Some peripherals can have DMA service during Deep-sleep mode without waking up entire device.

In Deep-sleep mode, all SRAM, logic state, and registers maintain their internal states. All SRAM instances that are not configured to enter in 'retention state' will stay in active state. Deep-sleep mode allows for very low quiescent power and fast wake-up options.

7.16.4 Power-down mode

In Power-down mode, nearly all on-chip power consumption is turned off by shutting down the internal DC-DC converter. The flash is powered down. The system clock to the CPU is stopped and if not configured, the peripherals receives no clocks. Through the power profiles API, selected peripherals such as Flexcomm interfaces 3 (SPI, I2C, USART, I2S), RTC, OS Timer, and comparator can be left running in power-down mode. Clock sources such as FRO 32 kHz, and the 32.768 kHz RTC clock can be enabled or disabled via software.

The chip can wake up from Power-down mode via a reset, digital pins selected as inputs to the group interrupt block, OS Timer, RTC alarm, an interrupt from the Flexcomm Interface 3 (SPI, I2C, I2S, USART), and comparator.

In Power-down mode, the CPU processor state is retained to allow resumption of code execution when a wake-up event occurs.

All SRAM, logic state, and registers maintain their internal states. All SRAM instances that are not configured to enter in 'retention state' will enter in 'shutdown' state.

7.16.5 Deep Power-down mode

In Deep Power-down mode, power is shut off to the entire chip except for the RTC power domain, the $\overline{\text{RESET}}$ pin, 4 Wake-up pins, and the OT Timer if enabled. Clock sources such as FRO 32 kHz, and the 32.768 kHz RTC clock can be enabled or disabled via software. The chip can wake up from Deep Power-down mode via the $\overline{\text{RESET}}$ pin, the RTC alarm, four special wake-up pins, or without an external signal, by using the time-out of the OS Timer. The ALARM1HZ flag in RTC control register generates an RTC wake-up interrupt request, which can wake up the part. SRAM can maintain their internal states. All SRAM instances that are not configured to enter in 'retention state' will enter in 'shutdown' state. In Deep Power-down mode all functional pins are in tri-state.

7.17 General Purpose I/O (GPIO)

The chip provides GPIO ports 0 and 1 with a total of up to 64 GPIO pins.

Device pins that are not connected to a specific peripheral function are controlled by the GPIO registers. Pins may be dynamically configured as inputs or outputs. Separate registers allow setting or clearing any number of outputs simultaneously. The current level of a port pin can be read back no matter what peripheral is selected for that pin.

See [Table 5](#) for the default state on reset.

7.17.1 Features

- Accelerated GPIO functions:
 - GPIO registers are located on the AHB so that the fastest possible I/O timing can be achieved.
 - Mask registers allow treating sets of port bits as a group, leaving other bits unchanged.
 - All GPIO registers are byte and half-word addressable.
 - Entire port value can be written in one instruction.
- Bit-level set, clear, and toggle registers allow a single instruction set, clear or toggle of any number of bits in one port.
- Direction control of individual bits.
- All I/O default to inputs after reset.
- All GPIO pins can be selected to create an edge or level-sensitive GPIO interrupt request.
- Two GPIO group interrupts can be triggered by a combination of any pin or pins to reflect two distinct interrupt patterns.
- The grouped interrupts can wake up the part from sleep, deep-sleep, and power-down modes.

7.18 Pin interrupt/pattern engine

The pin interrupt block configures up to eight pins from all digital pins for providing eight external interrupts connected to the NVIC. The pattern match engine can be used in conjunction with software to create complex state machines based on pin inputs. Any digital pin, independent of the function selected through the switch matrix can be configured through the SYSCON block as an input to the pin interrupt or pattern match engine. The registers that control the pin interrupt or pattern match engine are located on the I/O+ bus for fast single-cycle access.

7.18.1 Features

- Pin interrupts:
 - Up to eight pins can be selected from all GPIO pins on ports 0 and 1 as edge-sensitive or level-sensitive interrupt requests. Each request creates a separate interrupt in the NVIC.
 - Edge-sensitive interrupt pins can interrupt on rising or falling edges or both.
 - Level-sensitive interrupt pins can be HIGH-active or LOW-active.
 - Level-sensitive interrupt pins can be HIGH-active or LOW-active.
 - Pin interrupts can wake up the device from sleep mode, and deep-sleep mode.
- Pattern match engine:
 - Up to eight pins can be selected from all digital pins on ports 0 and 1 to contribute to a boolean expression. The boolean expression consists of specified levels and/or transitions on various combinations of these pins.
 - Each bit slice minterm (product term) comprising of the specified boolean expression can generate its own, dedicated interrupt request.
 - Any occurrence of a pattern match can also be programmed to generate an RXEV notification to the CPU. The RXEV signal can be connected to a pin.
 - Pattern match can be used in conjunction with software to create complex state machines based on pin inputs.
 - Pattern match engine facilitates wake-up only from active and sleep modes.

7.19 Communication peripherals

7.19.1 Full-speed USB Host/Device Interface (USB0)

The USB is a 4-wire bus that supports communication between a host and one or more (up to 127) peripherals. The host controller allocates the USB bandwidth to attached devices through a token-based protocol. The bus supports hot plugging and dynamic configuration of the devices. All transactions are initiated by the host controller.

7.19.1.1 USB0 device controller

The device controller enables 12 Mbit/s data exchange with a USB host controller. It consists of a register interface, serial interface engine, endpoint buffer memory. The serial interface engine decodes the USB data stream and writes data to the appropriate endpoint buffer. The status of a completed USB transfer or error condition is indicated via status registers. An interrupt is also generated if enabled.

Features

- USB2.0 full-speed device controller supporting crystal-less operation in device mode using software library example in technical note.
- Supports ten physical (five logical) endpoints including one control endpoint.
- Single and double-buffering supported.
- Each non-control endpoint supports bulk, interrupt, or isochronous endpoint types.
- Supports wake-up from Deep-sleep mode on USB activity and remote wake-up.
- Supports SoftConnect.
- Link Power Management (LPM) supported.

7.19.1.2 USB0 host controller

The host controller enables full- and low-speed data exchange with USB devices attached to the bus. It consists of register interface, serial interface engine and DMA controller. The register interface complies with the Open Host Controller Interface (OHCI) specification.

Features

- OHCI compliant.
- Two downstream ports.

7.19.2 Flexcomm Interface serial communication

Each Flexcomm Interface provides a choice of peripheral functions, one of which must be chosen by the user before the function can be configured and used.

7.19.2.1 Features

- USART with asynchronous operation or synchronous master or slave operation.
- SPI master or slave with up to 4 slave selects.
- I²C, including separate master, slave, and monitor functions.
- Flexcomm interfaces 0 to 5 each provide one channel pair of I²S and Flexcomm interfaces 6 to 7 each provide four channel pairs of I2S.
- Data for USART, SPI, and I2S traffic uses the Flexcomm FIFO. The I²C function does not use the FIFO.

7.19.2.2 SPI serial I/O (SPI0) controller

Features

Maximum supported bit rate for SPI master mode (transmit/receive) is 50 Mbit/s. The maximum supported bit rate for SPI slave receive mode is 20 Mbit/s (100 MHz ≤ CPU clock ≤ 150 MHz) / 12.5 Mbit/s (CPU clock < 100 MHz) and for SPI slave transmit mode is 50 Mbits/s.

- Master and slave operation.
- Data frames of 4 to 16 bits supported directly. Larger frames supported by software.
- The SPI function supports separate transmit and receive FIFOs with eight entries each.

- Supports DMA transfers: SPI transmit and receive functions can be operated with the system DMA controller.
- Data can be transmitted to a slave without the need to read incoming data. This can be useful while setting up an SPI memory.
- Up to Four Slave Select input/outputs with selectable polarity and flexible usage.

7.19.2.3 I²C-bus interface

The I²C-bus is bidirectional for inter-IC control using only two wires: a serial clock line (SCL) and a serial data line (SDA). Each device is recognized by a unique address and can operate as either a receiver-only device (for example, an LCD driver) or a transmitter with the capability to both receive and send information (such as memory). Transmitters and/or receivers can operate in either master or slave mode, depending on whether the chip has to initiate a data transfer or is only addressed. The I²C is a multi-master bus and can be controlled by more than one bus master connected to it.

Features

- Support standard, Fast-mode, and Fast-mode Plus (specific I²C pins) with data rates of up to 1 Mbit/s.
- Support high-speed slave mode with data rates of up to 3.4 Mbit/s (specific I²C pins).
- Independent Master, Slave, and Monitor functions.
- Supports both Multi-master and Multi-master with Slave functions.
- Multiple I²C slave addresses supported in hardware.
- One slave address can be selectively qualified with a bit mask or an address range in order to respond to multiple I²C-bus addresses.
- 10-bit addressing supported with software assist.
- Supports SMBus.
- Separate DMA requests for master, slave, and monitor functions.
- No chip clocks are required in order to receive and compare an address as a slave, so this event can wake-up the device from deep-sleep mode.
- Automatic modes optionally allow less software overhead for some use cases.

7.19.2.4 USART

Features

- Maximum bit rates of 10 Mbit/s in asynchronous mode and 12 Mbit/s in synchronous mode for USART functions.
- 7, 8, or 9 data bits and 1 or 2 stop bits.
- Synchronous mode with master or slave operation. Includes data phase selection and continuous clock option.
- Multiprocessor/multidrop (9-bit) mode with software address compare.
- RS-485 transceiver output enable.
- Autobaud mode for automatic baud rate detection
- Parity generation and checking: odd, even, or none.
- Software selectable oversampling from 5 to 16 clocks in asynchronous mode.

- One transmit and one receive data buffer.
- RTS/CTS for hardware signaling for automatic flow control. Software flow control can be performed using Delta CTS detect, Transmit Disable control, and any GPIO as an RTS output.
- Received data and status can optionally be read from a single register
- Break generation and detection.
- Receive data is 2 of 3 sample "voting". Status flag set when one sample differs.
- Built-in Baud Rate Generator with auto-baud function.
- A fractional rate divider is shared among all USARTs.
- Interrupts available for Receiver Ready, Transmitter Ready, Receiver Idle, change in receiver break detect, Framing error, Parity error, Overrun, Underrun, Delta CTS detect, and receiver sample noise detected.
- Loopback mode for testing of data and flow control.
- In synchronous slave mode, wakes up the part from deep-sleep and deep-sleep2 modes.
- Special operating mode allows operation at up to 9600 baud using the 32.768 kHz RTC oscillator as the UART clock. This mode can be used while the device is in deep-sleep and can wake-up the device when a character is received.
- USART transmit and receive functions work with the system DMA controller.
- The USART function supports separate transmit and receive FIFO with 16 entries each.

7.19.2.5 I²S-bus interface

The I²S bus provides a standard communication interface for streaming data transfer applications such as digital audio or data collection. The I²S bus specification defines a 3-wire serial bus with one data, one clock, and one word select/frame trigger signal, providing single or dual (mono or stereo) audio data transfer in addition to other configurations. Each Flexcomm Interface (0 to 5) implements one I²S channel pair and each Flexcomm Interface (6 to 7) implement four I²S channel pairs.

The I²S interface within one Flexcomm Interface provides one channel pair that can be configured as a master or a slave. Other channel pairs, if present, always operate as slaves. All of the channel pairs within one Flexcomm Interface share one set of I²S signals, and are configured together for either transmit or receive operation, using the same mode, same data configuration, and frame configuration. All such channel pairs can participate in a Time Division Multiplexing (TDM) arrangement. For cases requiring an MCLK input and/or output, this is handled outside of the I²S block in the system level clocking scheme.

Features

- A Flexcomm Interface can implement one or more I²S channel pairs, the first of which could be a master or a slave, and the rest would be slaves. All channel pairs are configured together for either transmit or receive and other shared attributes.
- Flexcomm interfaces 0 to 5 each provide one channel pair of I²S function. Other channel pairs, if present, always operate as slaves.

- Configurable data size for all channels within one Flexcomm Interface, from 4 bits to 32 bits. Each channel pair can also be configured independently to act as a single channel (mono as opposed to stereo operation).
- All channel pairs within one Flexcomm Interface share a single bit clock (SCK) and word select/frame trigger (WS), and data line (SDA).
- Data for all I²S traffic within one Flexcomm Interface uses the Flexcomm FIFO. The FIFO depth is 8 entries.
- Left justified and right justified data modes.
- DMA support using FIFO level triggering.
- TDM with a several stereo slots and/or mono slots is supported. Each channel pair can act as any data slot. Multiple channel pairs can participate as different slots on one TDM data line.
- The bit clock and WS can be selectively inverted.
- Sampling frequencies supported depends on the specific device configuration and applications constraints (For example, system clock frequency and PLL availability) but generally supports standard audio data rates.

7.19.3 High-Speed SPI serial I/O (SPIO controller)

7.19.3.1 Features

- Master and slave operation.
- Excluding delays introduced by external device and PCB, the maximum supported bit rate for SPI master mode (transmit/receive) is 50 Mbit/s.
Excluding delays introduced by external device and PCB, the maximum supported bit rate for SPI slave receive mode is 50 Mbit/s and for SPI slave transmit mode is 30 Mbit/s (100 MHz ≤ CPU clock ≤ 150 MHz) and 25 Mbit/s (CPU clock < 100 MHz).
- Data frames of 4 to 16 bits supported directly. Larger frames supported by software.
- The SPI function supports separate transmit and receive FIFOs with eight entries each.
- Supports DMA transfers: SPI transmit and receive functions can be operated with the system DMA controller.
- Data can be transmitted to a slave without the need to read incoming data. This can be useful while setting up an SPI memory.
- Up to Four Slave Select input/outputs with selectable polarity and flexible usage.

7.19.4 I3C interface

The MIPI Alliance Improved Inter-Integrated Circuit (MIPI I3C) brings major improvements in use and power over I2C, and provides an alternative to SPI for mid-speed applications. The I3C bus is designed to support future sensor interface architectures, widely expected in Internet-of-Things applications. The I3C bus is intended to be used by microcontrollers (MCU) and application processors (AP) to connect to sensors, actuators, and other MCUs (as slaves). Connecting an MCU to other MCUs and connecting an AP to an MCU are considered to be the major use cases.

7.19.4.1 Features

- In-band interrupts: interrupts can go from Slave to Master without extra wires, such that the Master knows which Slave sent the interrupt.
- In-band command codes (Common Command Codes (CCC)).
- Dynamic addressing.
- Multi-master / multi-drop.
- Hot-Join.
- I2C compatibility. Note that I2C compatibility has limitations. Please refer to Reference Manual for further details.

7.20 CAN Flexible Data (CAN FD) interface

The chip contains a CAN FD interface.

7.20.1 Features

- Conforms with CAN protocol version 2.0 part A, B and ISO 11898-1.
- CAN FD with up to 64 data bytes supported.
- CAN Error Logging.
- AUTOSAR support.
- SAE J1939 support.
- Improved acceptance filtering.

7.21 Standard counter/timers (CT32B0 to 4)

The chip includes five general-purpose 32-bit timer/counters.

The timer/counter is designed to count cycles of the system derived clock or an externally-supplied clock. It can optionally generate interrupts, generate timed DMA requests, or perform other actions at specified timer values, based on four match registers. Each timer/counter also includes two capture inputs to trap the timer value when an input signal transitions, optionally generating an interrupt.

7.21.1 Features

- A 32-bit timer/counter with a programmable 32-bit prescaler.
- Counter or timer operation.
- Up to four 32-bit capture channels per timer, that can take a snapshot of the timer value when an input signal transitions. A capture event may also generate an interrupt.
- The timer and prescaler may be configured to be cleared on a designated capture event. This feature permits easy pulse width measurement by clearing the timer on the leading edge of an input pulse and capturing the timer value on the trailing edge.
- Four 32-bit match registers that allow:
 - Continuous operation with optional interrupt generation on match.
 - Stop timer on match with optional interrupt generation.

- Reset timer on match with optional interrupt generation.
- Up to four external outputs per timer corresponding to match registers with the following capabilities:
 - Set LOW on match.
 - Set HIGH on match.
 - Toggle on match.
 - Do nothing on match.
- Up to two match registers can be used to generate timed DMA requests.
- Up to 4 match registers can be configured for PWM operation, allowing up to 3 single edged controlled PWM outputs. WM mode using up to three match channels for PWM output.

7.22 SCTimer/PWM subsystem

The SCTimer/PWM is a flexible timer module capable of creating complex PWM waveforms and performing other advanced timing and control operations with minimal or no CPU intervention.

The SCTimer/PWM can operate as a single 32-bit counter or as two independent, 16-bit counters in uni-directional or bi-directional mode. It supports a selection of match registers against which the count value can be compared, and capture registers where the current count value can be recorded when some pre-defined condition is detected.

The SCTimer/PWM module supports multiple separate events that can be defined by the user based on some combination of parameters including a match on one of the match registers, and/or a transition on one of the SCTimer/PWM inputs or outputs, the direction of count, and other factors.

Every action that the SCTimer/PWM block can perform occurs in direct response to one of these user-defined events without any software overhead. Any event can be enabled to:

- Start, stop, or halt the counter.
- Limit the counter which means to clear the counter in unidirectional mode or change its direction in bi-directional mode.
- Set, clear, or toggle any SCTimer/PWM output.
- Force a capture of the count value into any capture registers.
- Generate an interrupt or DMA request.

7.22.1 Features

- The SCTimer/PWM Supports:
 - Eight inputs.
 - Ten outputs.
 - Sixteen match/capture registers.
 - Sixteen events.
 - Thirty two states.
 - Match register 0 to 5 support a fractional component for the dither engine .

- Counter/timer features:
 - Each SCTimer/PWM is configurable as two 16-bit counters or one 32-bit counter.
 - Counters clocked by system clock or selected input.
 - Configurable number of match and capture registers. Up to sixteen match and capture registers total.
 - Sixteen events.
 - Thirty two states.
 - Upon match and/or an input or output transition create the following events: interrupt; stop, limit, halt the timer or change counting direction; toggle outputs; change the state.
 - Counter value can be loaded into capture register triggered by a match or input/output toggle.
- PWM features:
 - Counters can be used in conjunction with match registers to toggle outputs and create time-proportioned PWM signals.
 - Up to ten single-edge or eight dual-edge PWM outputs with independent duty cycle and common PWM cycle length.
- Event creation features:
 - The following conditions define an event: a counter match condition, an input (or output) condition such as an rising or falling edge or level, a combination of match and/or input/output condition.
 - Selected events can limit, halt, start, or stop a counter or change its direction.
 - Events trigger state changes, output toggles, interrupts, and DMA transactions.
 - Match register 0 can be used as an automatic limit.
 - In bi-directional mode, events can be enabled based on the count direction.
 - Match events can be held until another qualifying event occurs.
- State control features:
 - A state is defined by events that can happen in the state while the counter is running.
 - A state changes into another state as a result of an event.
 - Each event can be assigned to one or more states.
 - State variable allows sequencing across multiple counter cycles.
 - Dither engine for improved average resolution of pulse edges.

7.23 Windowed Watchdog Timer (WWDT)

The purpose of the Watchdog Timer is to reset or interrupt the microcontroller within a programmable time if it enters an erroneous state. When enabled, a watchdog reset is generated if the user program fails to feed (reload) the Watchdog within a predetermined amount of time.

7.23.1 Features

- Internally resets chip if not reloaded during the programmable time-out period.

- Optional windowed operation requires reload to occur between a minimum and maximum time period, both programmable.
- Optional warning interrupt can be generated at a programmable time prior to watchdog time-out.
- Programmable 24-bit timer with internal fixed pre-scaler.
- Selectable time period from 1,024 watchdog clocks ($TWDCLK \times 256 \times 4$) to over 67 million watchdog clocks ($TWDCLK \times 224 \times 4$) in increments of four watchdog clocks.
- “Safe” watchdog operation. Once enabled, requires a hardware reset or a Watchdog reset to be disabled.
- Incorrect feed sequence causes immediate watchdog event if enabled.
- The watchdog reload value can optionally be protected such that it can only be changed after the “warning interrupt” time is reached.
- Flag to indicate Watchdog reset.
- The watchdog clock (WDCLK) is generated from always on FRO_1MHz clock which can be divided by WDT clock divider register. The accuracy of this clock is limited to +/- 15% over temperature, voltage, and silicon processing variations.
- The Watchdog timer can be configured to run in Deep-sleep mode.
- Debug mode.

7.24 Code Watchdog Timer (CDOG)

Code Watchdog Timer for detecting code flow integrity.

7.24.1 Features

- Secure Counter (SEC_CNT) to detect altered software in the execution flow.
- Instruction Timer (INST_TIMER) which places a hard upper-limit on the interval between checks of the secure counter.

7.25 RTC timer

The RTC block can be used to count seconds and generate an alarm interrupt to the processor whenever the counter value equals the value programmed into the associated 32-bit match register.

7.25.1 Features

- The RTC resides in a separate “always-on” voltage domain with battery backup. It utilizes an independent oscillator which is also in the “always-on” domain.
- The RTC oscillator has the following clock outputs: 32.768 kHz clock (named as 32 kHz clock in rest of this chapter) 32 kHz clock, selectable for system clock and CLKOUT pin, 1 Hz clock for RTC timing, and 1024 Hz clock (named as 1 kHz clock in rest of this chapter) for high-resolution RTC timing.
- 32-bit, 1 Hz RTC counter and associated match register for alarm generation.
- 15-bit, 32kHz sub-second counter (not in always-on domain).
- Separate 16-bit high-resolution/wake-up timer clocked at 1 kHz for 1 ms resolution with a more that one minute maximum time-out period.

- RTC alarm and high-resolution/wake-up timer time-out each generate independent interrupt requests that go to one NVIC channel. Either time-out can wake up the part from any of the low power modes, including deep power-down.
- Eight 32-bit general purpose registers can retain data in deep power-down or in the event of a power failure, provided there is battery backup.
- Calendar Feature.

7.26 Multi-Rate Timer (MRT)

The Multi-Rate Timer (MRT) provides a repetitive interrupt timer with four channels. Each channel can be programmed with an independent time interval, and each channel operates independently from the other channels.

7.26.1 Features

- 24-bit interrupt timer.
- Four channels independently counting down from individually set values.
- Repeat interrupt, one-shot interrupt, and one-shot bus stall modes.

7.27 OS Timer

42-bit free running timer with individual match/capture and interrupt generation logic used as continuous time-base for the system, available in any reduced power modes. It runs on 32kHz clock source, allowing a count period of more than 4 years.

7.27.1 Features

- Central 42-bit, free-running gray-code event/timestamp timer.
- Match registers compared to the main counter to generate an interrupt and/or wake-up event.
- Capture registers triggered by CPU command, readable via the AHB/IPS bus.
- APB interface for register access.
- IRQ and wake-up.
- Reads of gray-encoded timers are accomplished with no synchronization latency.

7.28 Micro-tick timer (UTICK)

The ultra-low power Micro-tick Timer, running from the Watchdog oscillator, can be used to wake up the device from Sleep and Deep-sleep modes.

7.28.1 Features

- Ultra simple timer.
- Write once to start.
- Interrupt or software polling.
- Four capture registers that can be triggered by external pin transitions.

7.29 Motor Control Subsystem

The following motor control subsystems are provided.

7.29.1 FlexPWM

Two FlexPWMs with 4 sub-modules, providing 24 PWM outputs, supporting two 3-phase motors..

7.29.1.1 Features

- Supports Velocity and Position control of BLDC & PMSM motors.
- Implements Field Orient Control (FOC) using Back EMF to improve motor efficiency.
- Programmable supports to place PWM outputs in inactive state during Stop, Wait, Debug states.
- Enable dither support (FRAC=0).

7.29.2 QEI

Two Quadrature Encoder/Decoders (QEIs) are available.

The enhanced quadrature Encoder/ decoder module provides interfacing capability to position/speed sensors used in industrial motor control applications. It has five input signals: PHASEA, PHASEB, INDEX, TRIGGER, and HOME. This module is used to decode shaft position, revolution count and speed.

7.29.3 OpAmps

Three OpAmps with programmable VREF are available on the chip.

7.29.4 Comparators

Four analog comparators (One comparator in the always On domain and three high speed comparators in the Core domain) can compare voltage levels on external pins and internal voltages.

7.29.4.1 Features

- Selectable external inputs can be used as either the positive or negative input of the comparator.
- Voltage ladder source selectable between the supply, multiplexing between internal VDD_MAIN and ACMP0VREF.
- 32-stage voltage ladder can be used as either the positive or negative input of the comparator.
- Supports standard and low power modes
- Interrupt capability.

7.30 Digital peripherals

7.30.1 DMA controller

The DMA controller allows peripheral-to memory, memory-to-peripheral, and memory-to-memory transactions. Each DMA stream provides unidirectional DMA transfers for a single source and destination.

Two identical DMA controllers are provided on the chip.

7.30.1.1 Features

- DMA0: 52 channels, 45 of which are connected to peripheral DMA requests. These come from the Flexcomm (USART, SPI, I2C, and I2S), high-speed SPI interface, ADC, AES, and SHA interfaces. 53 trigger sources are available.
- DMA1: 16 channels, 12 of which are connected to peripheral DMA requests. These come from the Flexcomm Interfaces, high-speed SPI interface, AES, and SHA interfaces. 25 trigger sources are available.
- DMA operations can be triggered by on-chip or off-chip events.
- Priority is user selectable for each channel (up to eight priority levels).
- Continuous priority arbitration.
- Address cache with four entries.
- Efficient use of data bus.
- Supports single transfers up to 1,024 words.
- Address increment options allow packing and/or unpacking data.

7.30.2 DMIC subsystem

The DMIC subsystem, including the dual-channel digital PDM microphone interface (DMIC) and hardware voice activity detector (HWVAD), is available.

7.30.2.1 Features

- Pulse-Density Modulation (PDM) data input for 2-left and/or 2-right channels (four in total) on 1 or 2 buses (Total: 2 channels).
- Flexible decimation.
- 16 entry FIFO for each channel.
- DC blocking or unaltered DC bias can be selected.

7.30.3 CRC engine

The Cyclic Redundancy Check (CRC) generator with programmable polynomial settings supports several CRC standards commonly used. To save system power and bus bandwidth, the CRC engine supports DMA transfers.

7.30.3.1 Features

- Supports three common polynomials CRC-CCITT, CRC-16, and CRC-32.
 - CRC-CCITT: $x^{16} + x^{12} + x^5 + 1$
 - CRC-16: $x^{16} + x^{15} + x^2 + 1$
 - CRC-32: $x^{32} + x^{26} + x^{23} + x^{22} + x^{16} + x^{12} + x^{11} + x^{10} + x^8 + x^7 + x^5 + x^4 + x^2 + x + 1$
- Bit order reverse and 1's complement programmable setting for input data and CRC sum.
- Programmable seed number setting.
- Supports CPU PIO or DMA back-to-back transfer.
- Accept any size of data width per write: 8, 16 or 32-bit.
 - 8-bit write: 1-cycle operation.
 - 16-bit write: 2-cycle operation (8-bit x 2-cycle).

- 32-bit write: 4-cycle operation (8-bit x 4-cycle).
- Supports programmable CRC polynomial.

7.31 Analog peripherals

7.31.1 16-bit Analog-to-Digital Converters (ADC)

Four single-ended 16-bit or two differential input ADCs (selectable) with sample rate of 2.0 Msamples/sec in 16-bit mode and 3.2 Msamples/sec in 12-bit mode. Eight differential channel pairs, (or 16 single-ended channels), with multiple internal and external trigger inputs. The ADC supports four simultaneous conversions, under the control of two independent sequences.

7.31.1.1 Features

- 16-bit Linear successive approximation algorithm.
- Differential operation with 16-bit or 13-bit resolution.
- Single-ended operation with 16-bit or 12-bit resolution.
- Depending on the package, provides channel support for up to 23 analog input channels for conversion of external pin and from internal sources.
- Select external pin inputs paired for conversion as differential channel input.
- Measurement of on-chip analog sources such as DAC, temperature sensor or bandgap.
- Configurable analog input sample time.
- Configurable speed options to accommodate operation in low power modes of SoC.
- Trigger detect with up to 16 trigger sources with priority level configuration. Software or hardware trigger option for each.
- Fifteen command buffers allow independent options selection and channel sequence scanning.
- Automatic compare for less-than, greater-than, within range, or out-of-range with "store on true" and "repeat until true" options.
- Two independent result FIFOs each contains 16 entries. Each FIFO has configurable watermark and overflow detection.
- Interrupt, DMA, or polled operation.
- Linearity and gain offset calibration logic.

7.31.2 12-DAC Digital-to-Analog Converter (DAC)

Three 12-bit DAC with sample rates of up to 1.0 MSample/sec are available on the chip.

7.31.3 Temperature sensors

The ADC has dedicated input channels for on-chip temperature sensors that are mapped on channels 26.

7.32 Universally Unique Identifier (UUID)

Each device consists of a unique 128-bit IETF RFC4122 compliant non-sequential UUID. The UUID can be read from the device using `ffr_get_uuid` API.

7.33 Code Watchdog Timer (CDOG)

The Code Watchdog Timer (CDOG) module helps protect the integrity of software by detecting unexpected changes (faults) in code execution flow. The CDOG module can be configured to reset or interrupt the processor core when the module detects a fault. The CDOG includes the following code flow and data integrity checking:

- Faults and flags configurable to generate a system reset, interrupts, or nothing
- Counters for statistics on code behavior patterns for fault types

7.34 Code Read Protection

Code Read Protection is a mechanism that allows users to enable different levels of security in the system so they can protect both their software code and hardware. LPC553x devices have five different active security levels: CPR0, CRP1, CRP2, CRP3 and CRP4. Each mode increases the security level, with CRP4 restricting any access to the device only using Debug Mailbox command.

7.35 Emulation and debugging

Debug and trace functions are integrated into the Arm Cortex-M33 Serial wire debug and trace function (Serial Wire Output) are supported. Eight breakpoints and four watch points are supported. In addition, JTAG boundary scan mode is provided.

The Arm SYSREQ reset is supported and causes the processor to reset the peripherals, execute the boot code, restart from address 0x0000 0000, and break at the user entry point.

The SWD pins are multiplexed with other digital I/O pins. On reset, the pins assume the SWD functions by default.

ETM support is also available.

8. Limiting values

Table 8. Limiting values

In accordance with the Absolute Maximum Rating System (IEC 60134).^[1]

Symbol	Parameter	Conditions		Min	Max	Unit
V _{DD}	Main IO supply		[2]	-0.3	3.96	V
VDDIO_1	Supply of Digital/Analog I/Os. Must be equal to VDD_MAIN.		[2]	-0.3	3.96	V
VDDIO_2	Supply of Digital I/Os/Analog I/Os. For Digital functions, voltage can be less than or equal to VDD_MAIN. For Analog functions, voltage must be equal to VDD_MAIN.		[2]	-0.3	3.96	V
VDD_MAIN	Power control system.		[2]	-0.3	3.96	V
VDD_MAIN_PWR	High current/High transient current.		[2]	-0.3	3.96	V
VBAT	Battery Supply.		[2]	-0.3	3.96	V
VDD_CORE	Analog supply for Core. DC-DC output		[2]	-0.3	1.26	V
USB0_3V3	USB0 analog 3.3 V supply.		[2]	-0.3	3.96	V
V _{DDA}	Analog supply voltage for ADC		[2]	-0.3	3.96	V
V _{refp}	ADC positive reference voltage		[2]	-0.3	3.96	V
V _{BAT}	Battery supply voltage		[2]	0.3	3.96	V
V _I	input voltage	only valid when the V _{DD} ≥ 1.8 V	[5]	-0.5	V _{DD} + 0.5	V
V _I	input voltage	on I2C open-drain pins		-0.5	V _{DD} + 0.5	V
		USB_DM, USB_DP pins		-0.3	USB_3V3 + 0.5	V
V _{IA}	analog input voltage	on digital pins configured for an analog function	[6][7]	-0.3	3.96	V
I _{DD}	total supply current	per supply pin (HLQFP100, HTQFP64, HVQFN48)		-	256	mA
I _{SS}	total ground current	per ground pin (HLQFP100, HTQFP64, HVQFN48)		-	256	mA
I _{latch}	I/O latch-up current	-(0.5V _{DD}) < V _I < (1.5V _{DD}); T _j < 125 °C		-	100	mA

Table 8. Limiting values ...continued

In accordance with the Absolute Maximum Rating System (IEC 60134).[\[1\]](#)

Symbol	Parameter	Conditions		Min	Max	Unit
T _{stg}	storage temperature			-65	+150	°C
V _{ESD}	electrostatic discharge voltage	human body model; all pins	[3]		2000	V
V _{ESD}	electrostatic discharge voltage	charge device model; all pins	[3]		500	V

- [1] The following applies to the limiting values:
- This product includes circuitry specifically designed for the protection of its internal devices from the damaging effects of excessive static charge. Nonetheless, it is suggested that conventional precautions be taken to avoid applying greater than the rated maximum.
 - Parameters are valid over operating temperature range unless otherwise specified. All voltages are with respect to V_{SS} unless otherwise noted.
 - The limiting values are stress ratings only and operating the part at these values is not recommended and proper operation is not guaranteed. The conditions for functional operation are specified in [Table 20](#).
- [2] Maximum/minimum voltage above the maximum operating voltage (see [Table 20](#)) and below ground that can be applied for a short time (< 10 ms) to a device without leading to irrecoverable failure. Failure includes the loss of reliability and shorter lifetime of the device.
- [3] Human body model: equivalent to discharging a 100 pF capacitor through a 1.5 kΩ series resistor.
- [4] V_{DD} present or not present. Compliant with the I²C-bus standard. 5.5 V can be applied to this pin when V_{DD} is powered down.
- [5] Including the voltage on outputs in 3-state mode.
- [6] An ADC input voltage above 3.6 V can be applied for a short time without leading to immediate, unrecoverable failure. Accumulated exposure to elevated voltages at 4.6 V must be less than 10⁶ s total over the lifetime of the device. Applying an elevated voltage to the ADC inputs for a long time affects the reliability of the device and reduces its lifetime.
- [7] It is recommended to connect an overvoltage protection diode between the analog input pin and the voltage supply pin.

9. Thermal characteristics

The average chip junction temperature, T_j (°C), can be calculated using the following equation:

$$T_j = T_{amb} + (P_D \times R_{th(j-a)}) \quad (1)$$

- T_{amb} = ambient temperature (°C),
- $R_{th(j-a)}$ = the package junction-to-ambient thermal resistance (°C/W)
- P_D = sum of internal and I/O power dissipation

The internal power dissipation is the product of I_{DD} and V_{DD} . The I/O power dissipation of the I/O pins is often small and many times can be negligible. However it can be significant in some applications.

Table 9. Thermal resistance

Symbol	Parameter	Conditions	Max/Min	Unit
HLQFP100 Package				
$R_{th(j-a)}$	thermal resistance from junction to ambient [1]	JESD51-9, 2s2p [2]	26.7	°C/W
$R_{th(j-c)}$	thermal resistance from junction to case [3]	JESD51-9 [2]	2.4	°C/W
HTQFP 64 Package				
$R_{th(j-a)}$	thermal resistance from junction to ambient [1]	JESD51-9, 2s2p [2]	27.9	°C/W
$R_{th(j-c)}$	thermal resistance from junction to case [3]	JESD51-9 [2]	2.3	°C/W
HVQFN48 Package				
$R_{th(j-a)}$	thermal resistance from junction to ambient [1]	JESD51-9, 2s2p [2]	26.0	°C/W
$R_{th(j-c)}$	thermal resistance from junction to case [3]	JESD51-9 [2]	1.5	°C/W

Table 10. Maximum Junction Temperature

Symbol	Parameter	Conditions	Max	Unit
T_{jmax}	maximum junction temperature		+ 107	°C

- [1] Determined in accordance to JEDEC JESD51-2A natural convection environment. Thermal resistance data in this report is solely for a thermal performance comparison of one package to another in a standardized specified environment. It is not meant to predict the performance of a package in an application-specific environment
- [2] Thermal test board meets JEDEC specification for this package (JESD51-9).
- [3] Junction-to-Case thermal resistance determined using an isothermal cold plate. Case is defined as the bottom of the packages (exposed pad)

10. Static characteristics

10.1 General operating conditions

Table 11. General operating conditions

$T_{amb} = -40\text{ }^{\circ}\text{C}$ to $+105\text{ }^{\circ}\text{C}$, unless otherwise specified.

Symbol	Parameter	Conditions	Min	Typ ^[1]	Max	Unit
f_{clk}	clock frequency	internal CPU/system clock	-	-	150	MHz
f_{clk}	clock frequency	For USB full-speed device and host operations	12	-	150	MHz
VDDIO_1	Supply of Digital/Analog I/Os. Must be equal to VDD_MAIN.		1.8	-	3.6	V
VDDIO_2	Supply of Digital I/Os/Analog I/Os. For Digital functions, voltage can be less than or equal to VDD_MAIN. For Analog functions, voltage must be equal to VDD_MAIN.		1.08	-	3.6	V
VDD_MAIN	Power control system		1.8	-	3.6	V
VDD_MAIN_PWR	High current/High transient current.		1.8	-	3.6	V
VDD_CORE ^[2]	Analog supply for Core. DC-DC output		1.0	-	1.2	V
USB0_3V3	USB0 analog 3.3 V supply.		3.0	-	3.6	V
V _{DDA}	Analog supply voltage for ADC		1.8	-	3.6	V
V _{refp}	ADC positive reference voltage		0.985	-	V _{DDA}	V
V _{BAT}	Battery supply voltage		1.71	-	3.6	V

[1] Typical ratings are not guaranteed. The values listed are for room temperature (25 °C), nominal supply voltages.

[2] Power library in SDK sets the DC-DC output or LDO output based on the frequency selected. For frequencies 100 MHz or below, DC-DC output or LDO output is set between 1.025 V to 1.075 V, for frequencies between 101 MHz to 130 MHz, DC-DC output or LDO output is set between 1.1 V to 1.175 V and for frequencies above 130 MHz, DC-DC output or LDO output is set between 1.150 V to 1.2 V. Typical default DC-DC output or LDO output is 1.1 V.

[3] See: [Section 13. "Application information"](#).

10.2 CoreMark data

Table 12. CoreMark score [6]

$T_{amb} = 25^{\circ}\text{C}$, $VDD_MAIN = VDD = 3.0\text{ V}$

Parameter	Conditions		Typ [2]	Unit
ARM Cortex-M33 in active mode				
CoreMark score	CoreMark code executed from SRAMX; CCLK = 12 MHz	[1][3]	4.0	(Iterations/s) / MHz
	CCLK = 48 MHz	[1][3]	4.0	(Iterations/s) / MHz
	CCLK = 60 MHz	[1][3]	4.0	(Iterations/s) / MHz
	CCLK = 96 MHz	[1][3]	4.0	(Iterations/s) / MHz
	CCLK = 100 MHz	[3][5]	4.0	(Iterations/s) / MHz
	CCLK = 150 MHz	[3][5]	4.0	(Iterations/s) / MHz
CoreMark score	CoreMark code executed from flash; cache enabled CCLK = 12 MHz; 2 system clock flash access time.	[1][3][4]	4.0	(Iterations/s) / MHz
	CCLK = 48 MHz, 5 system clock flash access time.	[1][3][4]	4.0	(Iterations/s) / MHz
	CCLK = 96 MHz, 9 system clock flash access time.	[1][3][4]	4.0	(Iterations/s) / MHz
	CCLK = 100 MHz, 9 system clock flash access time.	[3][4][5]	4.0	(Iterations/s) / MHz
	CCLK = 150 MHz, 13 system clock flash access time.	[3][4][5]	4.0	(Iterations/s) / MHz
CoreMark score	CoreMark code executed from flash; cache disabled CCLK = 12 MHz; 2 system clock flash access time.	[1][3][4]	3.8	(Iterations/s) / MHz
	CCLK = 48 MHz, 5 system clock flash access time.	[1][3][4]	3.0	(Iterations/s) / MHz
	CCLK = 96 MHz, 9 system clock flash access time.	[1][3][4]	2.4	(Iterations/s) / MHz
	CCLK = 100 MHz, 9 system clock flash access time.	[3][4][5]	2.3	(Iterations/s) / MHz
	CCLK = 150 MHz, 13 system clock flash access time.	[3][4][5]	1.9	(Iterations/s) / MHz

[1] Clock source FRO (12 MHz/96 MHz output FRO) PLL disabled

[2] Characterized through bench measurements using typical samples.

[3] Compiler settings: IAR v9.10, optimization level 3, optimized for time on.

[4] See the FMCCR (FLASHTIM bits) in the Reference Manual for system clock flash access time settings.

[5] PLL enabled

[6] Power library in SDK sets the DC-DC output or LDO output based on the frequency selected. For frequencies 100 MHz or below, DC-DC output or LDO output is set between 1.025 V to 1.075 V, for frequencies between 101 MHz to 130 MHz, DC-DC output or LDO output is set between 1.1 V to 1.175 V and for frequencies above 130 MHz, DC-DC output or LDO output is set between 1.150 V to 1.2 V. Typical default DC-DC output or LDO output is 1.1 V.

10.3 Power consumption

Table 13. Static characteristics LDO output: Power consumption in active mode [5]

$T_{amb} = -40\text{ }^{\circ}\text{C}$ to $+105\text{ }^{\circ}\text{C}$, unless otherwise specified.

Symbol	Parameter	Conditions		Min	Typ ^[1]	Typ ^[1]	Max	Unit
					(VDD_MAIN = 1.8 V)	(VDD_MAIN = 3.0 V)		
ARM Cortex-M33 in active mode								
I _{DD}	supply current	CoreMark code executed from SRAMX; flash powered down.						
		CCLK = 12 MHz	[2][3]	-	1.6	1.8	-	mA
		CCLK = 48 MHz	[2][3]	-	5.0	5.6	-	mA
		CCLK = 96 MHz	[2][3]	-	8.0	9.0	-	mA
		CCLK = 100 MHz	[3][4]	-	8.9	10.0	-	mA
		CCLK = 150 MHz	[3][4]	-	13.0	15.0	-	mA
I _{DD}	supply current	CoreMark code executed from flash; cache enabled						
		CCLK = 12 MHz; 2 system clock flash access time.	[2][3][6]	-	1.7	1.8	-	mA
		CCLK = 48 MHz; 5 system clock flash access time.	[2][3][6]	-	5.5	5.5	-	mA
		CCLK = 96 MHz, 9 system clock flash access time.	[2][3][6]	-	9.1	9.2	-	mA
		CCLK = 100 MHz, 9 system clock flash access time.	[3][4][6]	-	10.0	10.1	-	mA
		CCLK = 150 MHz, 13 system clock flash access time.	[3][4][6]	-	14.7	15.0	-	mA

- [1] Typical ratings are not guaranteed. Typical values listed are at room temperature (25 °C). Characterized through bench measurements using typical samples.
- [2] Clock source FRO (12 MHz/96 MHz output FRO) enabled. PLL disabled
- [3] Compiler settings: IAR v9.10, optimization level 0, optimized for time off.
- [4] PLL enabled
- [5] Power library in SDK sets the internal LDO output based on the frequency selected. For frequencies 100 MHz or below, internal LDO output is set between 1.025 V to 1.075 V, for frequencies between 101 MHz to 130 MHz, internal LDO output is set between 1.1 V to 1.175 V and for frequencies above 130 MHz, internal LDO output is set between 1.150 V to 1.2 V. Typical default internal LDO output is 1.1 V.
- [6] See the FMCCR (FLASHTIM bits) in the Reference Manual for system clock flash access time settings.

Table 14. Static characteristics DC-DC output: Power consumption in active mode [5]

$T_{amb} = -40\text{ }^{\circ}\text{C}$ to $+105\text{ }^{\circ}\text{C}$, unless otherwise specified.

Symbol	Parameter	Conditions		Min	Typ ^[1]	Typ ^[1]	Max	Unit
					(VDD_MAIN = 1.8 V)	(VDD_MAIN = 3.0 V)		
ARM Cortex-M33 in active mode								
I _{DD}	supply current	CoreMark code executed from SRAMX; flash powered down.						
		CCLK = 12 MHz	[2][3]	-	1.4	1.0	-	mA
		CCLK = 48 MHz	[2][3]	-	4.4	2.8	-	mA
		CCLK = 96 MHz	[2][3]	-	7.1	4.5	-	mA
		CCLK = 100 MHz	[3][4]	-	7.8	4.9	-	mA
		CCLK = 150 MHz	[3][4]	-	15.0	10.0	-	mA

Table 14. Static characteristics DC-DC output: Power consumption in active mode [5] ...continued

$T_{amb} = -40\text{ }^{\circ}\text{C}$ to $+105\text{ }^{\circ}\text{C}$, unless otherwise specified.

Symbol	Parameter	Conditions	Min	Typ ^[1]		Max	Unit	
				(VDD_MAIN = 1.8 V)	(VDD_MAIN = 3.0 V)			
I _{DD}	supply current	CoreMark code executed from flash; cache enable						
		CCLK = 12 MHz, 2 system clock flash access time.	[2][3][6]	-	1.6	0.98	-	mA
		CCLK = 48 MHz, 5 system clock flash access time.	[2][3][6]	-	4.9	2.7	-	mA
		CCLK = 96 MHz, 9 system clock flash access time.	[2][3][6]	-	8.0	4.4	-	mA
		CCLK = 100 MHz, 9 system clock flash access time.	[3][4][6]	-	8.7	4.8	-	mA
		CCLK = 150 MHz, 13 system clock flash access time.	[3][4][6]	-	17.1	9.9	-	mA

- [1] Typical ratings are not guaranteed. Typical values listed are at room temperature (25 °C). Characterized through bench measurements using typical samples.
- [2] Clock source FRO (12 MHz/96 MHz output FRO). PLL disabled
- [3] Compiler settings: IAR v9.10, optimization level 0, optimized for time off.
- [4] PLL enabled
- [5] Power library in SDK sets the DC-DC output based on the frequency selected. For frequencies 100 MHz or below, DC-DC output is set between 1.025 V to 1.075 V, for frequencies between 101 MHz to 130 MHz, DC-DC output is set between 1.1 V to 1.175 V and for frequencies above 130 MHz, DC-DC output is set between 1.150 V to 1.2 V. Typical default DC-DC output is 1.1 V.
- [6] See the FMCCR (FLASHTIM bits) in the Reference Manual for system clock flash access time settings.

Table 15. Static characteristics: Power consumption in Sleep mode

$T_{amb} = -40\text{ }^{\circ}\text{C}$ to $+105\text{ }^{\circ}\text{C}$, unless otherwise specified. VDD_MAIN = VDD = 3.0 V

Symbol	Parameter	Conditions	Min	Typ ^[1]	Max	Unit	
ARM Cortex-M33 in Sleep mode							
I _{DD}	supply current	CCLK = 12 MHz, PLL disabled	[1][2]	-	1.3	-	mA
		CCLK = 96 MHz, PLL disabled	[2]	-	5.0	-	mA

- [1] Typical ratings are not guaranteed. Typical values listed are at room temperature (25 °C)
- [2] Clock source FRO. PLL disabled

Table 16. Static characteristics: Power consumption in Deep-sleep, Power-down, and Deep Power-down modes

$T_{amb} = -40\text{ }^{\circ}\text{C}$ to $+105\text{ }^{\circ}\text{C}$; unless otherwise specified. I_{DD} is total current from VDD_MAIN, VDDA, and VDD supply domain. VSUPPLY = VDD_MAIN + VDD_MAIN_PWR + VDDA + VDDIO_n

Symbol	Parameter	Conditions	Min	Typ ^{[1][2]}	Max ^[3]	Unit	
I _{DD}	supply current	Deep-sleep mode: all SRAM on (128 KB)					
		$T_{amb} = 25\text{ }^{\circ}\text{C}$, VSUPPLY = 3.0 V	[2]	-	100	146	μA
		$T_{amb} = 105\text{ }^{\circ}\text{C}$, VSUPPLY = 3.0 V	[2]	-	1870	3094	μA

Table 16. Static characteristics: Power consumption in Deep-sleep, Power-down, and Deep Power-down modes
...continued

$T_{amb} = -40\text{ }^{\circ}\text{C}$ to $+105\text{ }^{\circ}\text{C}$; unless otherwise specified. I_{DD} is total current from VDD_MAIN, VDDA, and VDD supply domain.

Symbol	Parameter	Conditions	Min	Typ ^{[1][2]}	Max ^[3]	Unit
I _{DD}	supply current	Power-down mode:				
		CPU state retained SRAM_00/01 powered (8 KB) $T_{amb} = 25\text{ }^{\circ}\text{C}$, VSUPPLY = 3.0 V	-	8	-	μA
		CPU state retained SRAM_00/01 powered (8 KB) $T_{amb} = 105\text{ }^{\circ}\text{C}$, VSUPPLY = 3.0 V	-	135	-	μA
		CPU state retained RAM_X0, RAM00, RAM01 retained (24 KB) $T_{amb} = 25\text{ }^{\circ}\text{C}$, VSUPPLY = 3.0 V	-	9	12	μA
		CPU state retained RAM_X0, RAM00, RAM01 retained (24 KB) $T_{amb} = 105\text{ }^{\circ}\text{C}$, VSUPPLY = 3.0 V	-	162	252	μA
		CPU state retained 128 KB full retention $T_{amb} = 25\text{ }^{\circ}\text{C}$, VSUPPLY = 3.0 V	-	13	-	μA
		CPU state retained 128 KB full retention $T_{amb} = 105\text{ }^{\circ}\text{C}$, VSUPPLY = 3.0 V	-	260	-	μA

Table 16. Static characteristics: Power consumption in Deep-sleep, Power-down, and Deep Power-down modes
...continued

$T_{amb} = -40\text{ }^{\circ}\text{C}$ to $+105\text{ }^{\circ}\text{C}$; unless otherwise specified. I_{DD} is total current from VDD_MAIN, VDDA, and VDD supply domain.

Symbol	Parameter	Conditions	Min	Typ ^{[1][2]}	Max ^[3]	Unit
I _{DD}	supply current	Deep Power-down mode:				
		RTC disabled (RTC oscillator input grounded), 4 KB, SRAM_00 disabled) T _{amb} = 25 °C, VSUPPLY = 3.0 V, VBAT = 0 V	-	2.4	3.2	μA
		RTC disabled (RTC oscillator input grounded), 4 KB, SRAM_00 disabled) T _{amb} = 105 °C, VSUPPLY = 3.0 V, VBAT = 0 V	-	24	28	μA
		RTC oscillator running with external crystal (4 KB SRAM_00 disabled) T _{amb} = 25 °C, VSUPPLY = 3.0 V, VBAT = 0 V	-	2.6	-	μA
		RTC oscillator running with external crystal (4 KB SRAM_00 enabled) T _{amb} = 25 °C, VSUPPLY = 3.0 V, VBAT = 0 V	-	2.5	-	μA
I _{bat}	Supply current	RTC disabled (RTC oscillator input grounded), 4 KB, SRAM_00 disabled T _{amb} = 25 °C, VBAT = 3.0 V, VSUPPLY = 0 V	-	2.2	3	μA
		RTC disabled (RTC oscillator input grounded), 4 KB, SRAM_00 disabled T _{amb} = 105 °C, VBAT = 3.0 V, VSUPPLY = 0 V	-	10.6	13.2	μA

- [1] Typical ratings are not guaranteed. Typical values listed are at room temperature (25 °C).
- [2] Characterized through bench measurements using typical samples.
- [3] The maximum values represent characterized results equivalent to the mean plus three times the standard deviation (mean + 3 sigma).

Table 17. Static characteristics: ADC Power consumption

$T_{amb} = -40\text{ }^{\circ}\text{C}$ to $+105\text{ }^{\circ}\text{C}$, unless otherwise specified. $0.985\text{ V} \leq V_{REFP} \leq V_{DDA}\text{ V}$; $1.8\text{ V} \leq V_{DDA} \leq 3.6\text{ V}$.

Symbol	Parameter	Conditions	Min	Typ ^[1]	Max	Unit
I _{DDA}	analog supply current	ADC in low power mode (PWRSEL = 0) Idle mode (analog blocks pre-enabled, inc ADC Bias)	-	0.2	-	mA
		ADC in low power mode (PWRSEL = 0) Sampling/ SE Conversion mode (analog blocks ON) f _{adc} = 24 MHz	-	0.7	-	mA
		ADC in high power mode (PWRSEL = 3) Idle mode (analog blocks pre-enabled)	-	0.2	-	mA
		ADC in high power mode (PWRSEL = 3) Sampling/ SE Conversion mode (analog blocks ON) f _{adc} = 48 MHz	-	1.4	-	mA
		ADC in high power mode (PWRSEL = 3) PWRSEL = 3 Sampling/ DIFF or Dual SE Conversion mode (analog blocks ON) f _{adc} = 48 MHz	-	2.1	-	mA
		Temperature sensor (inc ADC Bias)	-	60	-	μA
IDDA	Analog supply Current	Deep Sleep mode, ADC OFF	-	10	-	nA
		Power-down mode, ADC OFF	-	6	-	nA
		Deep Power-down mode, ADC OFF	-	5	-	nA
IDD(VREFP)	VREFP supply current	ADC Idle mode (analog blocks pre_enabled)	-	5	-	nA
		Sampling/ SE Conversion mode (analog blocks ON) f _{adc} = 48 MHz	-	50	-	μA
		Sampling/DIFF or Dual SE Conversion mode (analog blocks ON) f _{adc} = 48 MHz	-	100	-	μA

[1] Typical ratings are not guaranteed. Typical values listed are at room temperature (25 °C), 3.0 V.

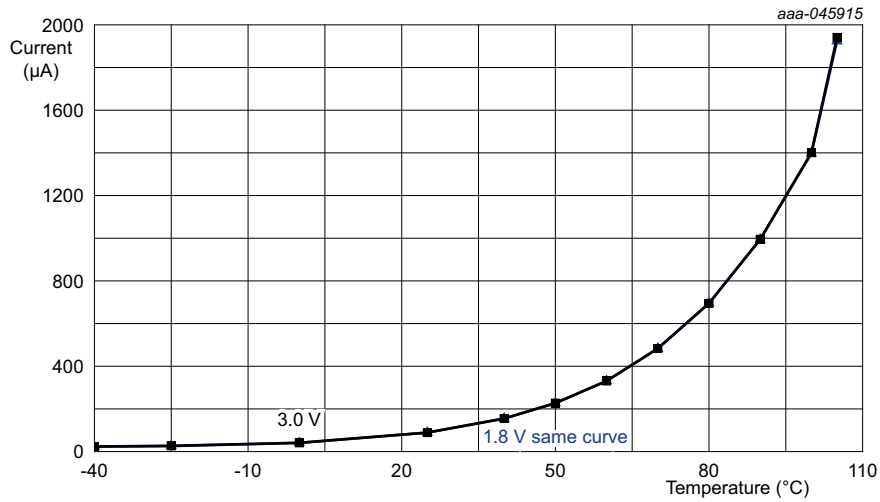

Fig 8. VDD_MAIN/VDD_MAIN_PWR power consumption in Deep-sleep mode (all SRAM on, 128 KB, 1.8 V, 3.0 V)

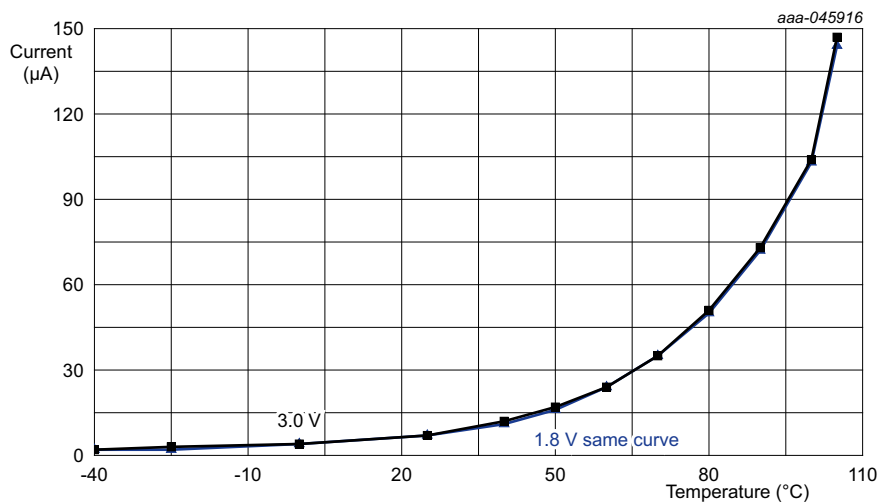

Fig 9. VDD_MAIN/VDD_MAIN_PWR power consumption in Power-down mode (CPU state retained, SRAM_00/01 powered (8 KB), 1.8V, 3.0 V)

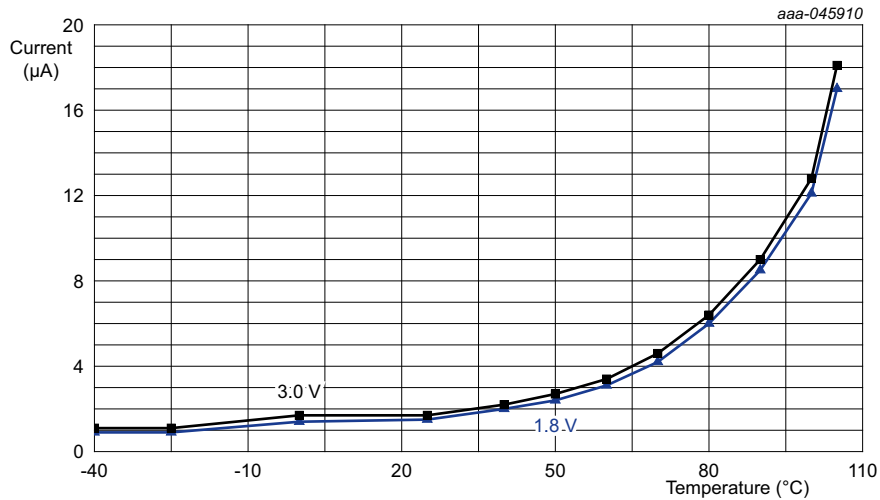

Fig 10. VDD_MAIN/VDD_MAIN_PWR power consumption in Deep-power Down mode, RTC disabled (RTC oscillator input grounded), 4 KB, SRAM_00 disabled, VDD_MAIN/VDD_MAIN_PWR = 1.8 V, 3.0 V, VBAT = 0V

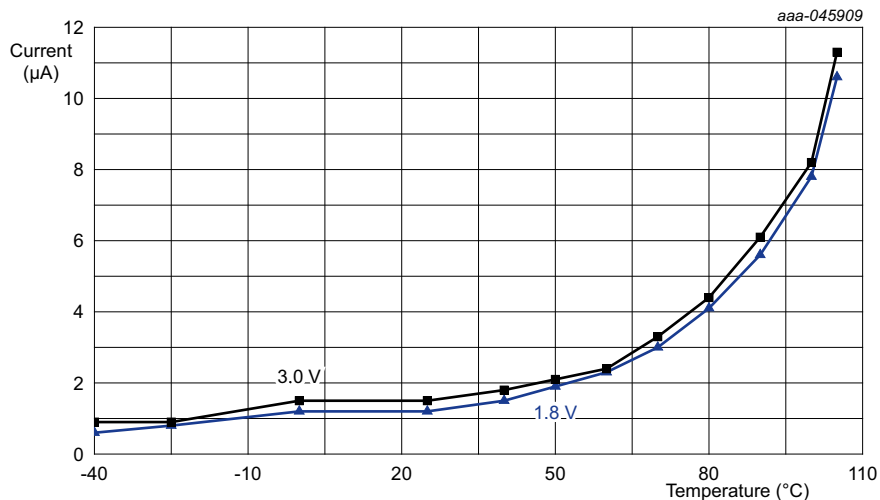

Fig 11. VBAT power consumption in Deep-power Down mode, RTC disabled (RTC oscillator input grounded), 4 KB, SRAM_00 disabled, VBAT = 1.8V, 3.0 V VDD_MAIN/VDD_MAIN_PWR = 0 V

10.3.1 Peripheral Power Consumption

Table 19 shows the typical peripheral power consumption measured on a typical sample at $T_{amb} = 25\text{ °C}$ and $VDD_MAIN = 3.3\text{ V}$. The supply current per peripheral is measured as the difference in supply current between the peripheral block enabled and the peripheral block disabled using AHB clock control and PDRUNCFG registers. All other blocks are disabled and no code accessing the peripheral is executed.

The supply currents are shown for system clock frequencies of 12 MHz, 96 MHz, and 150 MHz.

Table 18. Typical peripheral power consumption

VDD_MAIN = 3.3 V; T = 25 °C

Peripheral	I _{DD} (μA)
FRO (96 MHz)	778
FRO (12 MHz)	115
FRO (1 MHz)	45
FRO (32 kHz)	0.9
System OSC	46
32.768 kHz OSC	0.7
BOD_VDDMAIN	1.3
BOD_CORE	1.4

Table 19. Typical peripheral power consumption

VDD_MAIN = 3.3 V; T = 25 °C

Peripheral	I _{DD} in μA/MHz	I _{DD} in μA/MHz	I _{DD} in μA/MHz
	CPU: 12 MHz	CPU: 96 MHz	CPU: 150 MHz
ADC0	5.13	4.85	5.37
ADC1	5.27	4.84	5.40
Analog Comparator	0.60	0.75	0.82
AOI0	0.55	0.63	0.72
AOI1	0.55	0.69	0.72
CAN-FD	6.17	6.25	7.04
CodeWatchdog Timer	0.22	0.28	0.26
CRC	0.96	1.01	1.07
DAC0	0.11	0.82	1.01
DAC1	0.07	0.81	0.97
DAC2	0.47	0.94	1.11
DMA0	6.81	6.95	7.71
DMA1	2.87	2.99	3.28
DMIC	2.31	2.68	2.94
ENC0	1.41	1.54	1.65
ENC1	1.31	1.48	1.57
FLASH	2.71	2.71	2.97
Flexcomm Interface 0	1.70	1.79	1.98
Flexcomm Interface 1	1.64	1.89	2.89
Flexcomm Interface 2	2.89	3.25	3.65
Flexcomm Interface 3	1.57	2.19	2.48
Flexcomm Interface 4	2.74	3.23	3.65
Flexcomm Interface 5	3.13	3.64	4.10
Flexcomm Interface 6	3.37	3.83	4.28
Flexcomm Interface 7	3.03	3.38	3.79
FlexSPI	12.62	12.73	14.20

Table 19. Typical peripheral power consumption ...continued

VDD_MAIN = 3.3 V; T = 25 °C

Peripheral	I _{DD} in μ A/MHz	I _{DD} in μ A/MHz	I _{DD} in μ A/MHz
	CPU: 12 MHz	CPU: 96 MHz	CPU: 150 MHz
FMC	4.63	4.52	5.08
Frequency monitor (Freqme)	0.40	0.55	0.54
FTM0	0.22	0.31	0.29
GINT	0.53	0.62	0.67
GPIO0	1.27	1.34	1.44
GPIO1	1.21	1.32	1.43
GPIO2	1.27	1.30	1.45
High-Speed comparator0	0.35	0.42	0.44
High-Speed comparator1	0.31	0.39	0.47
High-Speed comparator2	0.33	0.40	0.48
HS SPI	0.01	1.43	1.96
I3C	2.64	2.75	3.12
INPUTMUX	3.42	3.55	3.90
IOCON	1.14	1.25	1.39
Mailbox	0.34	0.42	0.43
MRT	0.85	0.94	1.03
OPAMP0	0.22	0.27	0.34
OPAMP1	0.23	0.30	0.34
OPAMP2	0.19	0.28	0.31
OS Timer	0.84	1.01	1.09
OTP	0.42	0.55	0.54
Peripheral Input Mux 1	0.37	0.53	0.57
PINT	0.97	1.10	1.19
PowerQuad	1.98	2.13	2.29
PWM0	1.92	2.34	2.64
PWM1	2.21	2.66	2.98
ROM	2.07	2.22	2.38
RTC	1.20	1.30	1.41
SCTimer/PWM	3.70	4.10	4.61
Timer0	2.42	2.88	3.22
Timer1	2.30	2.69	3.04
Timer2	2.29	2.80	3.16
Timer3	2.33	2.66	3.04
Timer4	2.32	2.70	3.01
USB0 FS Device	5.86	6.50	7.23
USB FS Host Slave	4.71	5.38	5.90
USB FS Host Master	5.06	5.76	6.34

Table 19. Typical peripheral power consumption ...continued $VDD_MAIN = 3.3\text{ V}; T = 25\text{ }^{\circ}\text{C}$

Peripheral	I_{DD} in $\mu\text{A}/\text{MHz}$		I_{DD} in $\mu\text{A}/\text{MHz}$
	CPU: 12 MHz	CPU: 96 MHz	CPU: 150 MHz
UTICK	0.42	0.58	0.55
VREF	0.24	0.41	0.39
WWDT	0.52	0.68	0.69

[1] Turn off the peripheral when the configuration is done.

10.4 Pin characteristics

Table 20. Static characteristics: pin characteristics

$T_{amb} = -40\text{ }^{\circ}\text{C}$ to $+105\text{ }^{\circ}\text{C}$, unless otherwise specified. $1.8\text{ V} \leq VDDIO_1 \leq 3.6\text{ V}$; $1.8\text{ V} \leq VDDIO_2 \leq 3.6\text{ V}$; V unless otherwise specified. Values tested in production unless otherwise specified.

Symbol	Parameter	Conditions	Min	Typ [1]	Max	Unit
Standard I/O pins, RESET pin						
Input characteristics						
I_{IL}	LOW-level input current	$V_I = 0\text{ V}$; on-chip pull-up resistor disabled	-	2	200	nA
I_{IH}	HIGH-level input current	$V_I = V_{DD}$; on-chip pull-down resistor disabled	-	2	200	nA
V_I	input voltage	pin configured to provide a digital function; $VDDIO_x \geq 1.8\text{ V}$	[2] 0	-	3.6	V
V_{IH}	HIGH-level input voltage		$0.7 \times VDDIO_x$	-	$VDDIO_x$	V
V_{IL}	LOW-level input voltage		- 0.3	-	$0.3 \times VDDIO_x$	V
V_{hys}	hysteresis voltage		-	0.4	-	V
Output characteristics						
V_{OH}	HIGH-level output voltage	$I_{OH} = -4\text{ mA}$; $1.8\text{ V} \leq VDDIO_x < 2.7\text{ V}$	$VDDIO_x - 0.5$	-	-	V
		$I_{OH} = -4\text{ mA}$; $2.7\text{ V} \leq VDDIO_x \leq 3.6\text{ V}$	$VDDIO_x - 0.4$	-	-	V
V_{OL}	LOW-level output voltage	$I_{OL} = 4\text{ mA}$; $1.8\text{ V} \leq VDDIO_x < 2.7\text{ V}$	-	-	0.4	V
		$I_{OL} = 4\text{ mA}$; $2.7\text{ V} \leq VDDIO_x \leq 3.6\text{ V}$	-	-	0.4	V
Weak input pull-up/pull-down characteristics						
R_{pd}	pull-down resistance	$V_I = 0$	40	50	62	k Ω
R_{pu}	pull-up resistance	$V_I = VDDIO_x$	40	50	62	k Ω

Table 20. Static characteristics: pin characteristics ...continued

$T_{amb} = -40\text{ }^{\circ}\text{C}$ to $+105\text{ }^{\circ}\text{C}$, unless otherwise specified. $1.8\text{ V} \leq VDDIO_1 \leq 3.6\text{ V}$; $1.8\text{ V} \leq VDDIO_2 \leq 3.6\text{ V}$; V unless otherwise specified. Values tested in production unless otherwise specified.

Symbol	Parameter	Conditions	Min	Typ [1]	Max	Unit
Pin capacitance						
C_{io}	input/output capacitance	I ² C-bus pins	[3]	-	4.5	pF
		pins with digital functions only	[4]	-	2.5	pF
		Pins with digital and analog functions	[4]	-	3.0	pF

[1] Typical ratings are not guaranteed. The values listed are at room temperature (25 °C), 3.0 V.

[2] With respect to ground.

[3] The value specified is a simulated value, excluding package/bondwire capacitance.

[4] The values specified are simulated and absolute values, including package/bondwire capacitance.

Table 21. Static characteristics: pin characteristics

Based on simulation, typical silicon, 25 °C, $VDDIO_2 = 1.2\text{ V}$, not tested in production.

Symbol	Parameter	Conditions	Min	Typ [1]	Max	Unit
Standard I/O pins, RESET pin						
Input characteristics						
I_{IL}	LOW-level input current	$V_I = 0\text{ V}$; on-chip pull-up resistor disabled	-	2	200	nA
I_{IH}	HIGH-level input current	$V_I = V_{DD}$; on-chip pull-down resistor disabled	-	2	200	nA
V_I	input voltage	pin configured to provide a digital function; $VDDIO_2 \geq 1.08\text{ V}$	[2] 0	-	3.6	V
V_{IH}	HIGH-level input voltage		$0.7 \times VDDIO_2$	-	$VDDIO_2$	V
V_{IL}	LOW-level input voltage		- 0.3	-	$0.3 \times VDDIO_2$	V
V_{hys}	hysteresis voltage		-	0.4	-	V
Output characteristics						
V_{OH}	HIGH-level output voltage	$I_{OH} = -2\text{ mA}$	$VDDIO_2 - 0.5$	-	-	V
V_{OL}	LOW-level output voltage	$I_{OL} = 2\text{ mA}$	-	-	0.4	V
Weak input pull-up/pull-down characteristics						
R_{pd}	pull-down resistance	$V_I = 0$	40	50	62	kΩ
R_{pu}	pull-up resistance	$V_I = VDDIO_2$	40	50	62	kΩ

Table 21. Static characteristics: pin characteristics ...continued

Based on simulation, typical silicon, 25 °C, VDDIO_2 = 1.2 V, not tested in production.

Symbol	Parameter	Conditions	Min	Typ ^[1]	Max	Unit
Pin capacitance						
C _{io}	input/output capacitance	I ² C-bus pins	[3]	-	4.5	pF
		pins with digital functions only	[4]	-	2.5	pF
		Pins with digital and analog functions	[4]	-	3.0	pF

- [1] Typical ratings are not guaranteed. The values listed are at room temperature (25 °C), 1.2 V.
- [2] With respect to ground.
- [3] The value specified is a simulated value, excluding package/bondwire capacitance.
- [4] The values specified are simulated and absolute values, including package/bondwire capacitance.

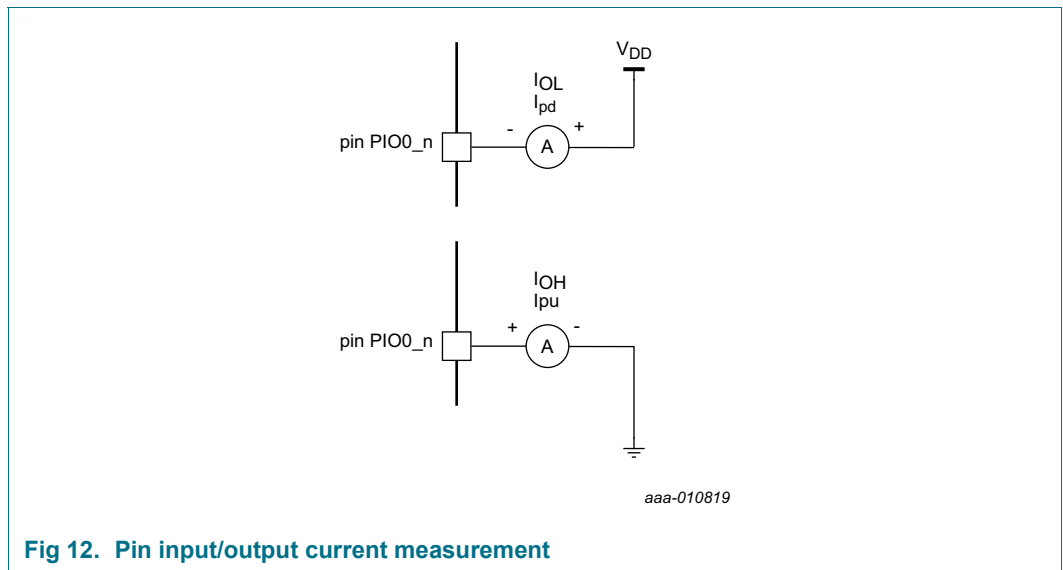

Fig 12. Pin input/output current measurement

11. Dynamic characteristics

11.1 Flash memory

Table 22. Flash characteristics

$T_{amb} = -40\text{ °C to }+105\text{ °C}$

Symbol	Parameter	Conditions	Min	Typ [2]	Max	Unit
N _{endu}	endurance	Page erase/program, $T_{amb} = -40\text{ °C to }+85\text{ °C}$	[1] 100000	-	-	cycles
		Mass erase/program, $T_{amb} = -40\text{ °C to }+85\text{ °C}$	100000	-	-	cycles
		Page erase/program $T_{amb} = -40\text{ °C to }+105\text{ °C}$,	100000	-	-	cycles
		Mass erase/program $T_{amb} = -40\text{ °C to }+105\text{ °C}$,	100000	-	-	cycles
t _{ret}	retention time	< 1k erase/program cycles	25	-	-	years
		≥ 1k erase/program cycles	15	-	-	years
t _{er}	erase time	1 page or multiple pages	-	2.0	-	ms
t _{prog}	programming time		-	1.09	-	ms
N _{updates}	number of page updates	1 page or multiple pages	-	-	50	million

[1] Number of erase/program cycles.

[2] Temperature = 25°C.

11.2 I/O pins

Table 23. Dynamic characteristic: I/O pins[1]

$T_{amb} = -40\text{ °C to }+105\text{ °C}$; $1.8\text{ V} \leq V_{DDIO_X} \leq 3.6\text{ V}$

Symbol	Parameter	Conditions	Min	Typ	Max	Unit
Standard I/O pins - normal drive strength						
t _r	rise time	pin configured as output; SLEW = 1	[2][3] 3	-	8	ns
t _f	fall time	pin configured as output; SLEW = 1	[2][3] 3	-	9	ns
t _r	rise time	pin configured as output; SLEW = 0	[2][3] 7	-	15	ns
t _f	fall time	pin configured as output; SLEW = 0	[2][3] 7	-	14	ns
I2C I/O pins - normal drive strength						
t _r	rise time	pin configured as output; SLEW = 1	[2][3] 3.0	-	11.0	ns
t _f	fall time	pin configured as output; SLEW = 1	[2][3] 3.0	-	7.0	ns
t _r	rise time	pin configured as output; SLEW = 0	[2][3] 21.5	-	39.0	ns
t _f	fall time	pin configured as output; SLEW = 0	[2][3] 29.8	-	36.0	ns

[1] Based on characterized, not tested in production

[2] Rise and fall times measured between 90% and 10% of the full input signal level.

[3] The slew rate is configured in the IOCON block the SLEW bit. See the Reference Manual.

Table 24. Dynamic characteristic: I/O pins

Based on simulation, typical silicon, 25 °C, $V_{DDIO_2} = 1.2 V$, not tested in production.

Symbol	Parameter	Conditions		Min	Typ	Max	Unit
Standard I/O pins - normal drive strength							
t_r	rise time	pin configured as output; SLEW = 1	[4][5]	3.1	-	8.2	ns
t_f	fall time	pin configured as output; SLEW = 1	[4][5]	3.1	-	8.6	ns
t_r	rise time	pin configured as output; SLEW = 0	[4][5]	7.1	-	14.6	ns
t_f	fall time	pin configured as output; SLEW = 0	[4][5]	6.5	-	13.7	ns

[4] Rise and fall times measured between 90% and 10% of the full input signal level.

[5] The slew rate is configured in the IOCON block the SLEW bit. See Reference Manual.

11.3 Wake-up process

Table 25. Dynamic characteristic: Typical wake-up times from low power modes

$V_{DD_MAIN} = V_{DD} = 3.3 V$; $T_{amb} = 25 °C$; using FRO as the system clock.

Symbol	Parameter	Conditions		Min	Typ ^{[1][2]}	Max	Unit
t_{wake}	wake-up time	from Sleep mode, 96 MHz, No PRIMASK backup and restore	[2][3]	-	3.2	-	μs
		from Deep-sleep mode with full SRAM retention (128 KB)	[2]	-	76	-	μs
		from Power-down mode with CPU retention and 8KB/24KB/128KB retained	[2]	-	405	-	μs
		from deep power-down mode; 0KB/4KB retained, RTC disabled; using RESET or WAKEUP pins.	[2]	-	2.9	-	μs

[1] Typical ratings are not guaranteed. The values listed are at room temperature (25 °C), nominal supply voltages.

[2] The wake-up time measured is the time between when a GPIO input pin is triggered to wake the device up from the low power modes and from when a GPIO output pin is set in the interrupt service routine (ISR) wake-up handler.

[3] FRO enabled, all peripherals off.

[4] RTC disabled. Wake-up from deep power-down causes the part to go through entire reset process. The wake-up time measured is the time between when the RESET pin is triggered to wake the device up and when a GPIO output pin is set in the reset handler. Wake-up time for non-secure mode.

[5] Compiler settings: IAR v8.40, High optimization

11.4 FRO (12 MHz/96 MHz) (extended temperature)

Table 26. Dynamic characteristic: FRO

$T_{amb} = -40 °C$ to $+105 °C$; $1.8 V \leq V_{DD_MAIN} \leq 3.6 V$.

Symbol	Parameter	Conditions	Min	Typ ^[1]	Max	Unit
$f_{osc(RC)}$	FRO clock frequency	-	11.76	12	12.24	MHz
$f_{osc(RC)}$	FRO clock frequency	-	94.08	96	97.92	MHz

[1] Typical ratings are not guaranteed. The values listed are at room temperature (25 °C), nominal supply voltages.

11.5 FRO (12 MHz/96 MHz)

Table 27. Dynamic characteristic: FRO

$T_{amb} = 0\text{ }^{\circ}\text{C to }+85\text{ }^{\circ}\text{C}; 1.8\text{ V} \leq VDD_MAIN \leq 3.6\text{ V}.$

Symbol	Parameter	Conditions	Min	Typ ^[1]	Max	Unit
$f_{osc(RC)}$	FRO clock frequency	-	11.88	12	12.12	MHz
$f_{osc(RC)}$	FRO clock frequency	-	95.04	96	96.96	MHz

[1] Typical ratings are not guaranteed. The values listed are at room temperature (25 °C), nominal supply voltages.

11.6 FRO (1 MHz)

Table 28. Dynamic characteristic: FRO

$T_{amb} = -40\text{ }^{\circ}\text{C to }+105\text{ }^{\circ}\text{C}; 1.8\text{ V} \leq VDD_MAIN \leq 3.6\text{ V}.$

Symbol	Parameter	Conditions	Min	Typ ^[1]	Max	Unit
$f_{osc(RC)}$	FRO clock frequency	-	0.85	1	1.15	MHz

[1] Typical ratings are not guaranteed. The values listed are at room temperature (25 °C), nominal supply voltages.

11.7 FRO (32 kHz)

Table 29. Dynamic characteristic: FRO

$T_{amb} = -40\text{ }^{\circ}\text{C to }+105\text{ }^{\circ}\text{C}; 1.8\text{ V} \leq VDD_MAIN \leq 3.6\text{ V}.$

Symbol	Parameter	Conditions	Min	Typ ^[1]	Max	Unit
$f_{osc(RC)}$	FRO clock frequency	-	32.11	32.768	33.42	kHz

[1] Typical ratings are not guaranteed. The values listed are at room temperature (25 °C), nominal supply voltages.

11.8 RTC oscillator

See [Section 13.3 "RTC oscillator"](#) for connecting the RTC oscillator to an external clock source.

Table 30. Dynamic characteristic: RTC oscillator

$T_{amb} = -40\text{ }^{\circ}\text{C to }+105\text{ }^{\circ}\text{C}; 1.8 \leq VDD_MAIN \leq 3.6\text{ V}$ ^[1]

Symbol	Parameter	Conditions	Min	Typ ^[1]	Max	Unit
f_i	input frequency	-	-	32.768		kHz

[1] Parameters are valid over operating temperature range unless otherwise specified.

11.9 I²C-bus

Table 31. Dynamic characteristic: I²C-bus pins^[1]

$T_{amb} = -40\text{ }^{\circ}\text{C to }+105\text{ }^{\circ}\text{C}; 1.8\text{ V} \leq VDD_MAIN \leq 3.6\text{ V}; 1.8\text{ V} \leq VDDIO_1 \leq 3.6\text{ V}$ ^[2]

Symbol	Parameter	Conditions	Min	Max	Unit
f_{SCL}	SCL clock frequency	Standard-mode	0	100	kHz
		Fast-mode	0	400	kHz
		Fast-mode Plus	0	1	MHz

Table 31. Dynamic characteristic: I²C-bus pins^[1]
 $T_{amb} = -40\text{ }^{\circ}\text{C to } +105\text{ }^{\circ}\text{C}; 1.8\text{ V} \leq VDD_MAIN \leq 3.6\text{ V}; 1.8\text{ V} \leq VDDIO_1 \leq 3.6\text{ V}$ ^[2]

Symbol	Parameter		Conditions	Min	Max	Unit
t _f	fall time	[4] [5] [6] [7]	of both SDA and SCL signals	-	300	ns
			Standard-mode	-	300	ns
			Fast-mode	-	120	ns
t _{LOW}	LOW period of the SCL clock		Standard-mode	4.7	-	μs
			Fast-mode	1.3	-	μs
			Fast-mode Plus	0.5	-	μs
t _{HIGH}	HIGH period of the SCL clock		Standard-mode	4.0	-	μs
			Fast-mode	0.6	-	μs
			Fast-mode Plus	0.26	-	μs
t _{HD;DAT}	data hold time	[3] [4] [8]	Standard-mode	0	-	μs
			Fast-mode	0	-	μs
			Fast-mode Plus	0	-	μs
t _{SU;DAT}	data set-up time	[9] [10]	Standard-mode	250	-	ns
			Fast-mode	100	-	ns
			Fast-mode Plus	50	-	ns

- [1] Guaranteed by design. No tested in production.
- [2] Parameters are valid over operating temperature range unless otherwise specified. See the I²C-bus specification *UM10204* for details.
- [3] t_{HD;DAT} is the data hold time that is measured from the falling edge of SCL; applies to data in transmission and the acknowledge.
- [4] A device must internally provide a hold time of at least 300 ns for the SDA signal (with respect to the V_{IH(min)} of the SCL signal) to bridge the undefined region of the falling edge of SCL.
- [5] C_b = total capacitance of one bus line in pF. If mixed with Hs-mode devices, faster fall times are allowed.
- [6] The maximum t_f for the SDA and SCL bus lines is specified at 300 ns. The maximum fall time for the SDA output stage t_f is specified at 250 ns. This allows series protection resistors to be connected in between the SDA and the SCL pins and the SDA/SCL bus lines without exceeding the maximum specified t_f.
- [7] In Fast-mode Plus, fall time is specified the same for both output stage and bus timing. If series resistors are used, designers should allow for this when considering bus timing.
- [8] The maximum t_{HD;DAT} could be 3.45 μs and 0.9 μs for Standard-mode and Fast-mode but must be less than the maximum of t_{VD;DAT} or t_{VD;ACK} by a transition time. This maximum must only be met if the device does not stretch the LOW period (t_{LOW}) of the SCL signal. If the clock stretches the SCL, the data must be valid by the set-up time before it releases the clock.
- [9] t_{SU;DAT} is the data set-up time that is measured with respect to the rising edge of SCL; applies to data in transmission and the acknowledge.
- [10] A Fast-mode I²C-bus device can be used in a Standard-mode I²C-bus system but the requirement t_{SU;DAT} = 250 ns must then be met. This will automatically be the case if the device does not stretch the LOW period of the SCL signal. If such a device does stretch the LOW period of the SCL signal, it must output the next data bit to the SDA line t_{r(max)} + t_{SU;DAT} = 1000 + 250 = 1250 ns (according to the Standard-mode I²C-bus specification) before the SCL line is released. Also the acknowledge timing must meet this set-up time.

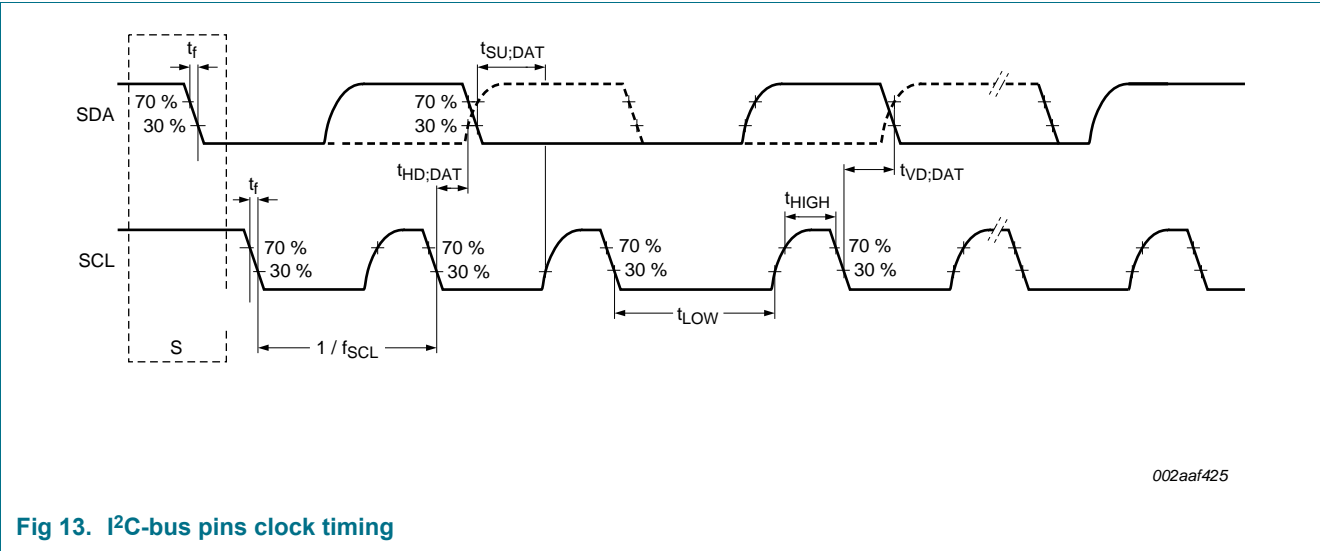

Fig 13. I²C-bus pins clock timing

11.10 MIPI I³C interface

Unless otherwise specified, MIPI I³C specifications are timed to/from the V_{IH} and /or V_{IL} signal points.

Table 32. MIPI I³C specifications when communication with legacy I²C devices

Symbol	Characteristic	400 kHz/Fast mode		1 MHz/ Fast+ mode		Unit
		Min	Max	Min	Max	
f _{SCL}	SCL Clock Frequency	0	0.4	0	1	MHz
t _{SU_STA}	Set-up time for a repeated START condition	600	-	260	-	ns
Hold time (repeated) START condition	t _{HD} ; STA	600	-	260	-	ns
t _{LOW}	LOW period of the SCL clock	1300	-	500	-	ns
t _{HIGH}	HIGH period of the SCL clock	600	-	260	-	ns
t _{SU_DAT}	Data set-up time	100	-	50	-	ns
t _{HD_DAT}	Data hold time for I ² C bus devices	-	-	-	-	ns
t _f	Fall time of SDA and SCL signals	20*(V _{dd} /5.5 v)	300	20*(V _{dd} /5.5 v)	120	ns
t _r	Rise time of SDA and SCL signals	20	300	-	120	ns
t _{SU_STO}	Set-up time for STOP condition	600	-	260	-	ns
t _{BUF}	Bus free time between STOP and START condition	1.3	-	0.5	-	μs
t _{SP}	Pulse width of spikes that must be suppressed by the input filter	0	50	0	50	ns

Table 33. MIPI I³C open drain mode specifications

Symbol	Characteristic	Min	Max	Unit	Notes	
t _{LOW_OD}	LOW period of the SCL clock	200	-	ns		
t _{DIG_OD_L}		t _{LOW_OD} + t _{rDA_OD} (min)	-	ns		
t _{HIGH}	HIGH period of the SCL clock	-	41	ns		
t _{rDA_OD}	Fall time of SDA signal	t _{CF}	12	ns	[1]	
t _{SU_OD}	Data set-up time during open drain mode	3	-	ns		
t _{CAS}	Clock after START (S) Condition	ENTAS0	38.4 n	1 μ	s	
		ENTAS1		100 μ	s	
		ENTAS2		2 m	s	
		ENTAS3		50 m	s	
t _{CBP}	Clock before STOP (P) condition	t _{CAS} (min)/2	-	s		
t _{MMO} overlap	Current master to secondary master overlap time during hand off	t _{DIG_OD_L}	-	ns		
t _{AVAIL}	Bus available condition	1	-	μs		
t _{IDLE}	Bus idle condition	1	-	ms		
t _{MMLock}	Time interval where new master not driving SDA low	t _{AVAIL}	-	μs		

[1] C_b = total capacitance of the one bus line in pF.

Table 34. MIPI I³C push-pull specifications for SDR and HDR-DDR modes

Symbol	Characteristic	Min	Typ	Max	Unit	Notes	
f _{SCL}	SCL Clock Frequency	0.01	12.5	13	MHz		
t _{LOW}	LOW period of the SCL clock	24	-	-	ns		
t _{DIG_L}		32	-	-	ns		
t _{HIGH_MIXED}	High period of the SCL clock for a mixed bus	24	-	-	ns		
t _{DIG_H_MIXED}		32	-	45	ns	[1]	
t _{HIGH}	HIGH period of the SCL clock	24	-	-	ns		
t _{DIG_H}		32	-	-	ns		
t _{SCO}	Clock in to data out for a slave	-	-	12	ns		
t _{CR}	SCL clock rise time	-	-	150 * 1/ f _{SCL} (capped at 60)	ns		
t _{CF}	SCL clock fall time	-	-	150 * 1/ f _{SCL} (capped at 60)	ns		
t _{HD_PP}	SDA signal data hold						
		Master mode	t _{CR} + 3 and t _{CF} + 3	-	-	ns	
		Slave mode	0	-	-	ns	
t _{SU_PP}	SDA signal setup	3	-	-	ns		
t _{CASr}	Clock after repeated START (Sr)	t _{CAS(min)}	-	-	ns		
t _{CBSr}	Clock before repeated START (Sr)	t _{CAS(min)} /2	-	-	ns		
C _b	Capacitive load per bus line	-	-	50	pF		

[1] When communication with an I³C Device on a mixed Bus, the t_{DIG_H} period must be constrained in order to make sure that I²C devices do not interpret I³C signaling as valid I²C signaling.

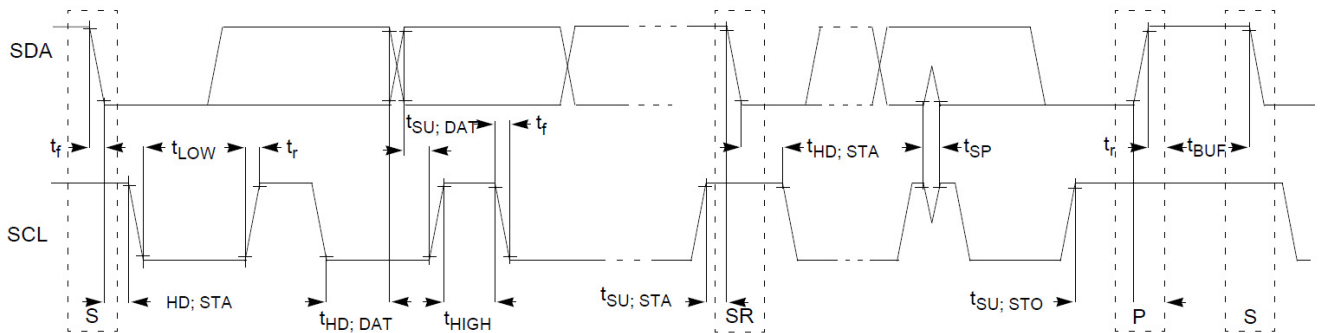

Fig 14. Timing definition for devices on the I²C bus

11.11 I²S-bus interface

Excluding delays introduced by external device and PCB, the maximum supported bit rate for I2S master mode (transmit/receive) is 24.58 Mbit/s (100 MHz ≤ CPU clock ≤ 150 MHz) and the maximum supported bit rate for I2S slave mode (transmit/receive) is 24.58 Mbit/s (100 MHz ≤ CPU clock ≤ 150 MHz).

Excluding delays introduced by external device and PCB, the maximum supported bit rate for I2S master transmit mode is 20 Mbit/s (CPU clock < 100 MHz) and I2S master receive mode is 15 Mbit/s (CPU clock < 100 MHz). The maximum supported bit rate for I2S slave receive mode is 20 Mbit/s (CPU clock < 100 MHz) and I2S slave receive mode is 15 Mbit/s (CPU clock < 100 MHz).

Table 35. Dynamic characteristics: I²S-bus interface pins [1][3]

T_{amb} = -40 °C to 105 °C; 1.8 V ≤ VDD_MAIN ≤ 3.6 V; 1.8 V ≤ VDDIO_1 ≤ 3.6 V; 1.08 V ≤ VDDIO_2 ≤ 3.6 V; C_L = 10 pF balanced loading on all pins; Input slew = 1.0 ns, SLEW setting = fast mode for all pins; Parameters sampled at the 50% level of the rising or falling edge.

Symbol	Parameter	Conditions	Min	Typ	Max	Unit	
Common to master and slave							
t _{WH}	pulse width HIGH	on pins I2Sx_TX_SCK and I2Sx_RX_SCK ^[4]	45%	-	55%	T _{cyc}	
t _{WL}	pulse width LOW	on pins I2Sx_TX_SCK and I2Sx_RX_SCK ^[4]	45%	-	55%	T _{cyc}	
Master							
t _{v(Q)}	data output valid time	on pin I2Sx_TX_SDA					
		CPU clock < 100 MHz ^[2]	0	-	20	ns	
		100 MHz ≤ CPU clock ≤ 150 MHz ^[2]	0	-	15	ns	
		on pin I2Sx_WS					
		CPU clock < 100 MHz ^[2]	0	-	20	ns	
		100 MHz ≤ CPU clock ≤ 150 MHz ^[2]	0	-	15	ns	
t _{su(D)}	data input set-up time	on pin I2Sx_RX_SDA					
		CPU clock < 100 MHz ^[2]	30	-	-	ns	
		100 MHz ≤ CPU clock ≤ 150 MHz ^[2]	16	-	-	ns	
t _{h(D)}	data input hold time	on pin I2Sx_RX_SDA					
			^[2] 0	-	-	ns	
Slave							
t _{v(Q)}	data output valid time	on pin I2Sx_TX_SDA ^[2]					
		CPU clock < 100 MHz	0	-	20	ns	
		100 MHz ≤ CPU clock ≤ 150 MHz	0	-	15	ns	
t _{su(D)}	data input set-up time	on pin I2Sx_RX_SDA ^[2]					
		CPU clock < 100 MHz	30	-	-	ns	
		100 MHz ≤ CPU clock ≤ 150 MHz	16	-	-	ns	
		on pin I2Sx_WS					
		CPU clock < 100 MHz	15	-	-	ns	
		100 MHz ≤ CPU clock ≤ 150 MHz	10	-	-	ns	

Table 35. Dynamic characteristics: I²S-bus interface pins [1][3]

$T_{amb} = -40\text{ }^{\circ}\text{C}$ to $105\text{ }^{\circ}\text{C}$; $1.8\text{ V} \leq VDD_MAIN \leq 3.6\text{ V}$; $1.8\text{ V} \leq VDDIO_1 \leq 3.6\text{ V}$; $1.08\text{ V} \leq VDDIO_2 \leq 3.6\text{ V}$; $C_L = 10\text{ pF}$ balanced loading on all pins; Input slew = 1.0 ns, SLEW setting = fast mode for all pins; Parameters sampled at the 50% level of the rising or falling edge.

Symbol	Parameter	Conditions	Min	Typ	Max	Unit
$t_{h(D)}$	data input hold time	on pin I2Sx_RX_SDA [2]	0	-	-	ns
		on pin I2Sx_WS	0	-	-	ns

- [1] Based on simulation; not tested in production.
- [2] Clock Divider register (DIV) = 0x0.
- [3] The Flexcomm Interface function clock frequency should not be above 48 MHz. See the data rates section in the I²S chapter of the Reference Manual to calculate clock and sample rates.
- [4] Based on simulation. Not tested in production.

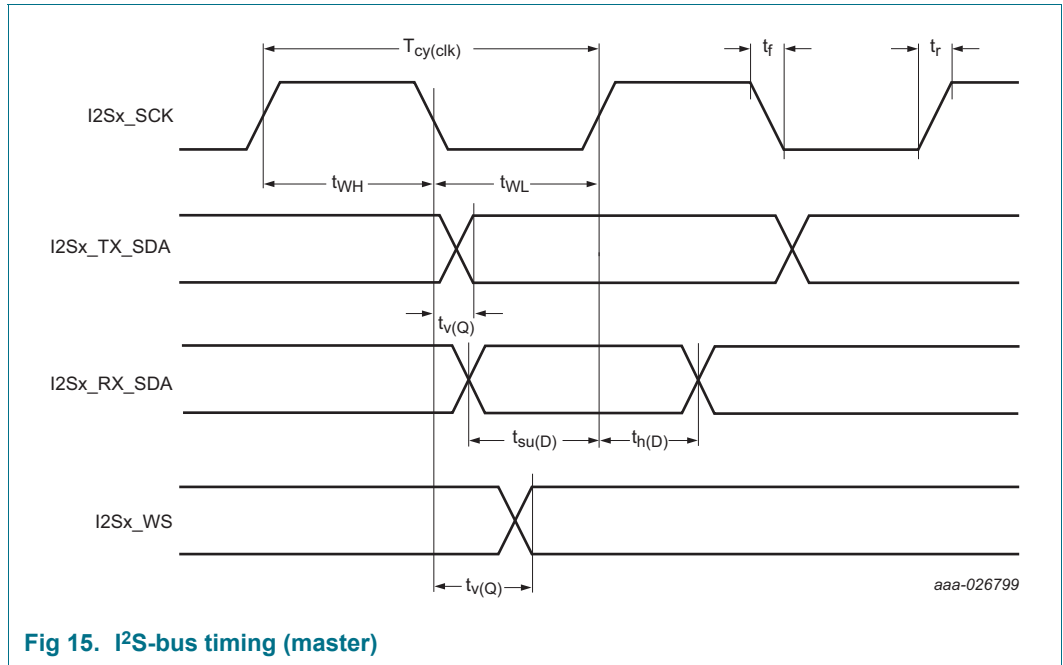

Fig 15. I²S-bus timing (master)

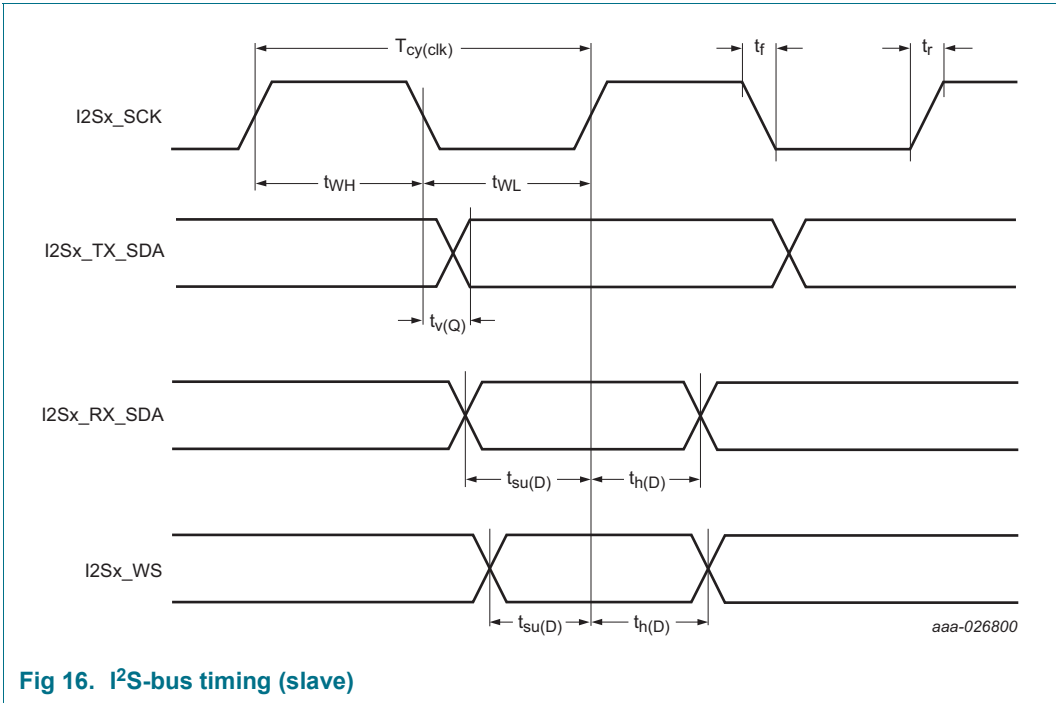

Fig 16. I²S-bus timing (slave)

11.12 SPI interface (Flexcomm Interfaces 0 - 7)

The actual SPI bit rate depends on the delays introduced by the external trace, the external device, system clock (CCLK), and capacitive loading.

Excluding delays introduced by external device and PCB, the maximum supported bit rate for SPI master mode (transmit/receive) is 50 Mbit/s.

Excluding delays introduced by external device and PCB, the maximum supported bit rate for SPI slave receive mode is 50 Mbit/s and for slave transmit mode is 20 Mbit/s (100 MHz \leq CPU clock \leq 150 MHz) and 12.5 Mbit/s (CPU clock < 100 MHz).

Table 36. SPI dynamic characteristics^[1]

$T_{amb} = -40\text{ }^{\circ}\text{C}$ to $105\text{ }^{\circ}\text{C}$; $1.8\text{ V} \leq VDD_MAIN \leq 3.6\text{ V}$; $1.8\text{ V} \leq VDDIO_1 \leq 3.6\text{ V}$; $1.08\text{ V} \leq VDDIO_2 \leq 3.6\text{ V}$; $C_L = 10\text{ pF}$ balanced loading on all pins; Input slew = 1 ns, SLEW setting = fast mode for all pins;. Parameters sampled at the 50% level of the rising or falling edge.

Symbol	Parameter	Conditions	Min	Typ	Max	Unit
SPI master						
t_{DS}	data set-up time		4	-	-	ns
t_{DH}	data hold time		0	-	-	ns
$t_{V(Q)}$	data output valid time		0	-	8	ns
SPI slave						
t_{DS}	data set-up time		5	-	-	ns
t_{DH}	data hold time		0	-	-	ns
$t_{V(Q)}$	data output valid time	CPU clock < 100 MHz	0	-	30	ns
		100 MHz \leq CPU clock \leq 150 MHz	0	-	20	ns

[1] Based on simulated values. Not tested in production

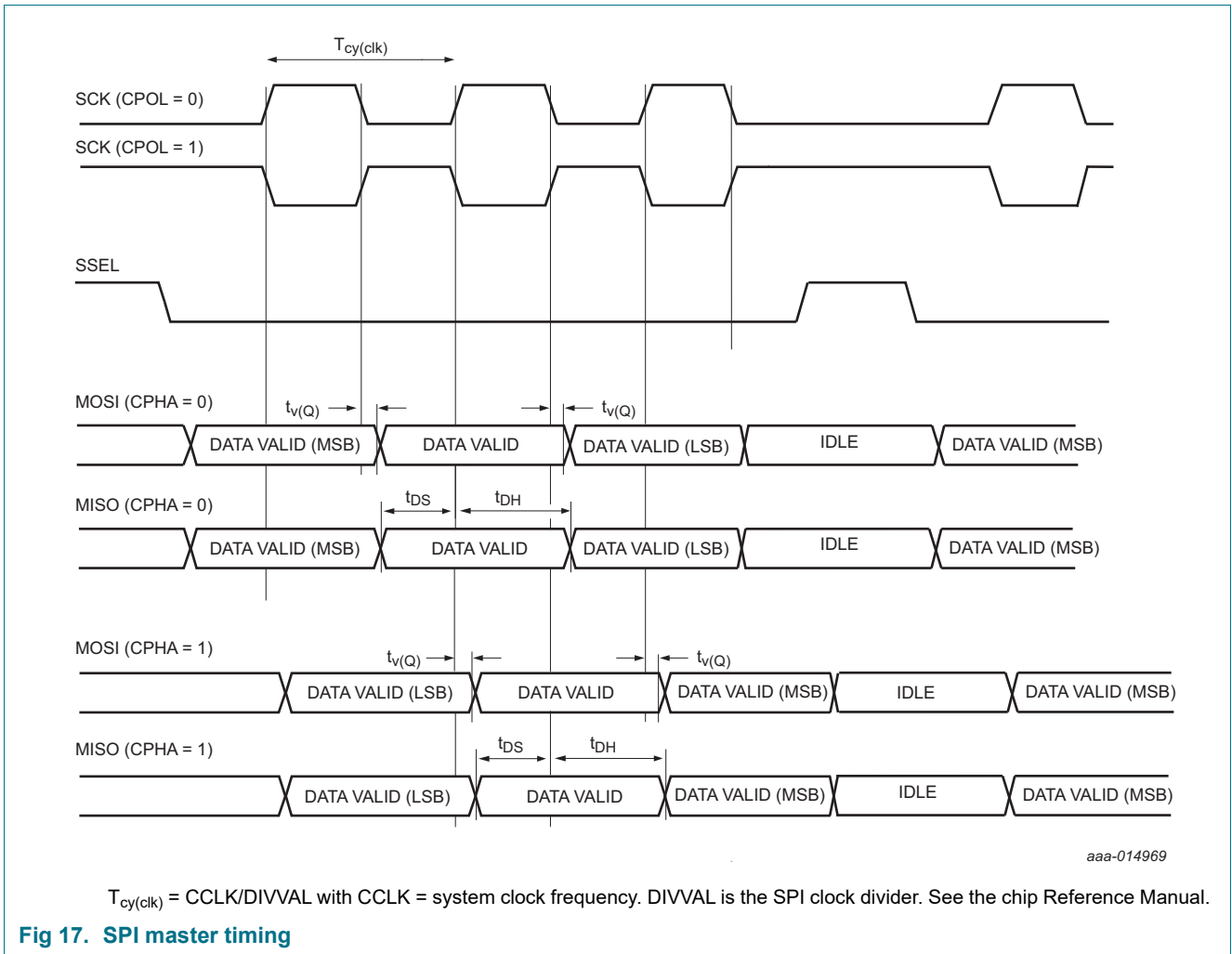

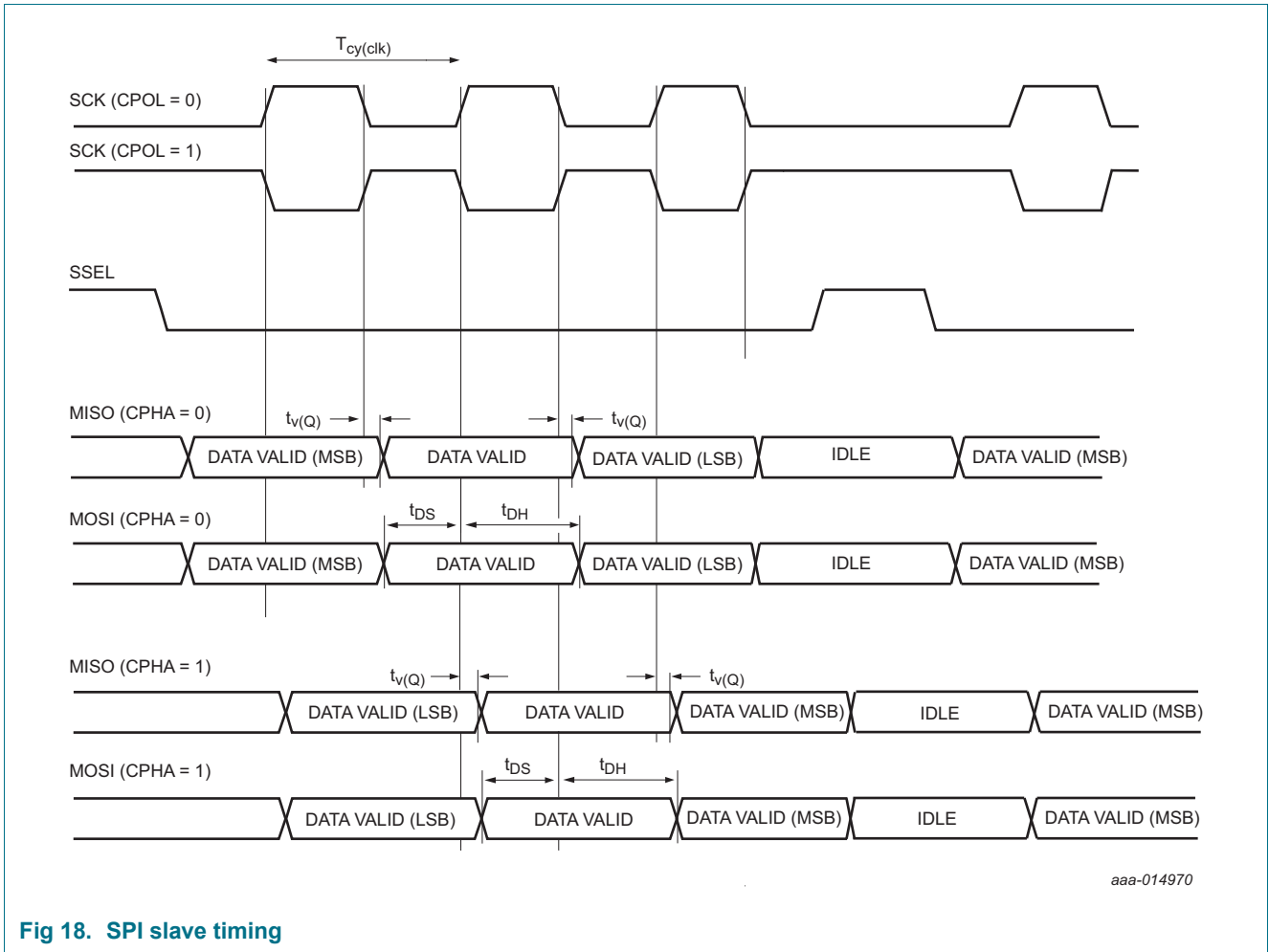

Fig 18. SPI slave timing

11.13 High-Speed SPI interface (Flexcomm Interface 8)

The actual SPI bit rate depends on the delays introduced by the external trace, the external device, system clock (CCLK), and capacitive loading. Excluding delays introduced by external device and PCB, the maximum supported bit rate for SPI master mode (transmit/receive) is 50 Mbit/s. Excluding delays introduced by external device and PCB, the maximum supported bit rate for SPI slave receive mode is 50 Mbit/s and for SPI slave transmit mode is 30 Mbit/s (100 MHz ≤ CPU clock ≤ 150 MHz) and 25 Mbit/s (CPU clock < 100 MHz).

Table 37. SPI dynamic characteristics^[1]

$T_{amb} = -40\text{ °C to }105\text{ °C}$; $T_{amb} = -40\text{ °C to }105\text{ °C}$; $1.8\text{ V} \leq VDD_MAIN \leq 3.6\text{ V}$; $1.8\text{ V} \leq VDDIO_1 \leq 3.6\text{ V}$; $1.08\text{ V} \leq VDDIO_2 \leq 3.6\text{ V}$; $C_L = 10\text{ pF}$ balanced loading on all pins; Input slew = 1 ns, SLEW setting = fast mode for all pins;. Parameters sampled at the 50% level of the rising or falling edge.

Symbol	Parameter	Conditions	Min	Typ	Max	Unit
SPI master						
t _{DS}	data set-up time		3	-	-	ns
t _{DH}	data hold time		0	-	-	ns
t _{V(Q)}	data output valid time		0	-	4	ns
SPI slave						
t _{DS}	data set-up time		3	-	-	ns
t _{DH}	data hold time		0	-	-	ns
t _{V(Q)}	data output valid time	CPU clock < 100 MHz	0	-	16	ns
		100 MHz ≤ CPU clock ≤ 150 MHz	0	-	10	ns

[1] Based on simulated values. Not tested in production.

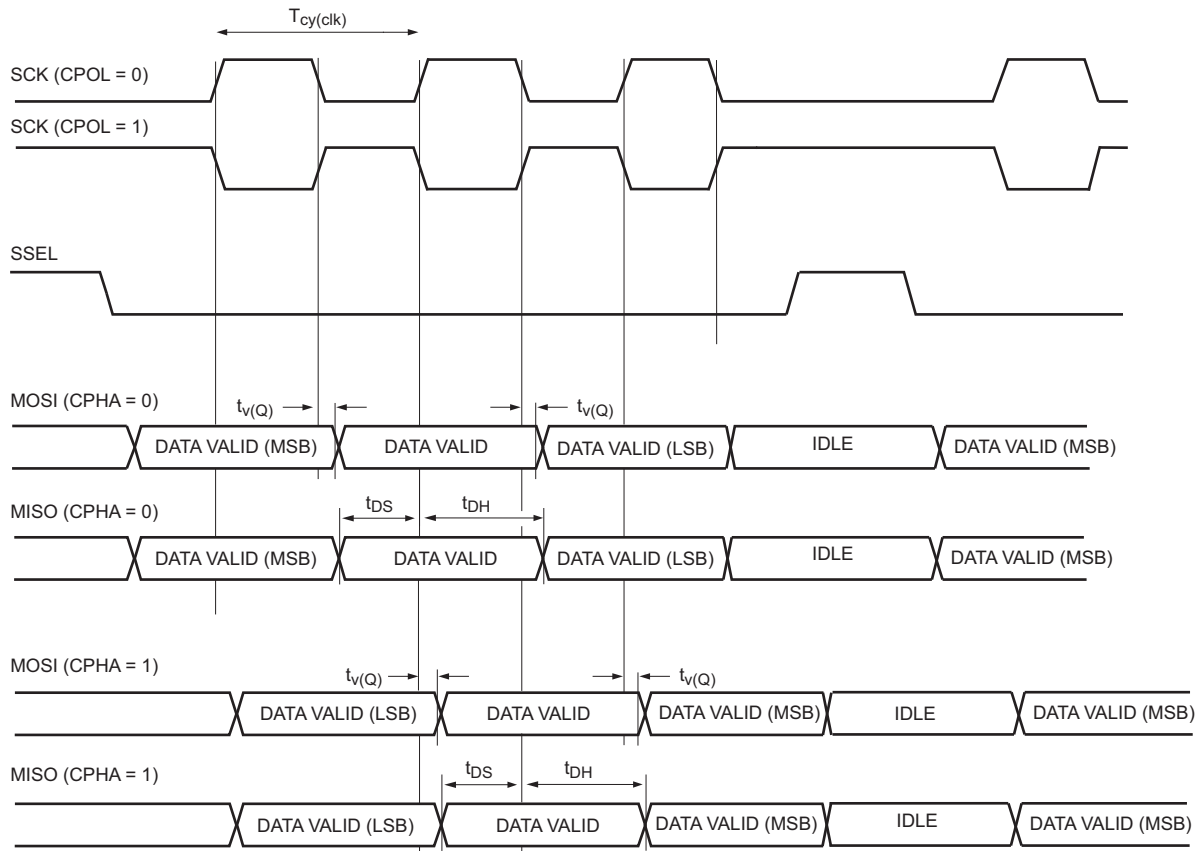

aaa-014969

$T_{cy}(clk) = CCLK/DIVVAL$ with CCLK = system clock frequency. DIVVAL is the SPI clock divider. See the chip Reference Manual.

Fig 19. SPI master timing

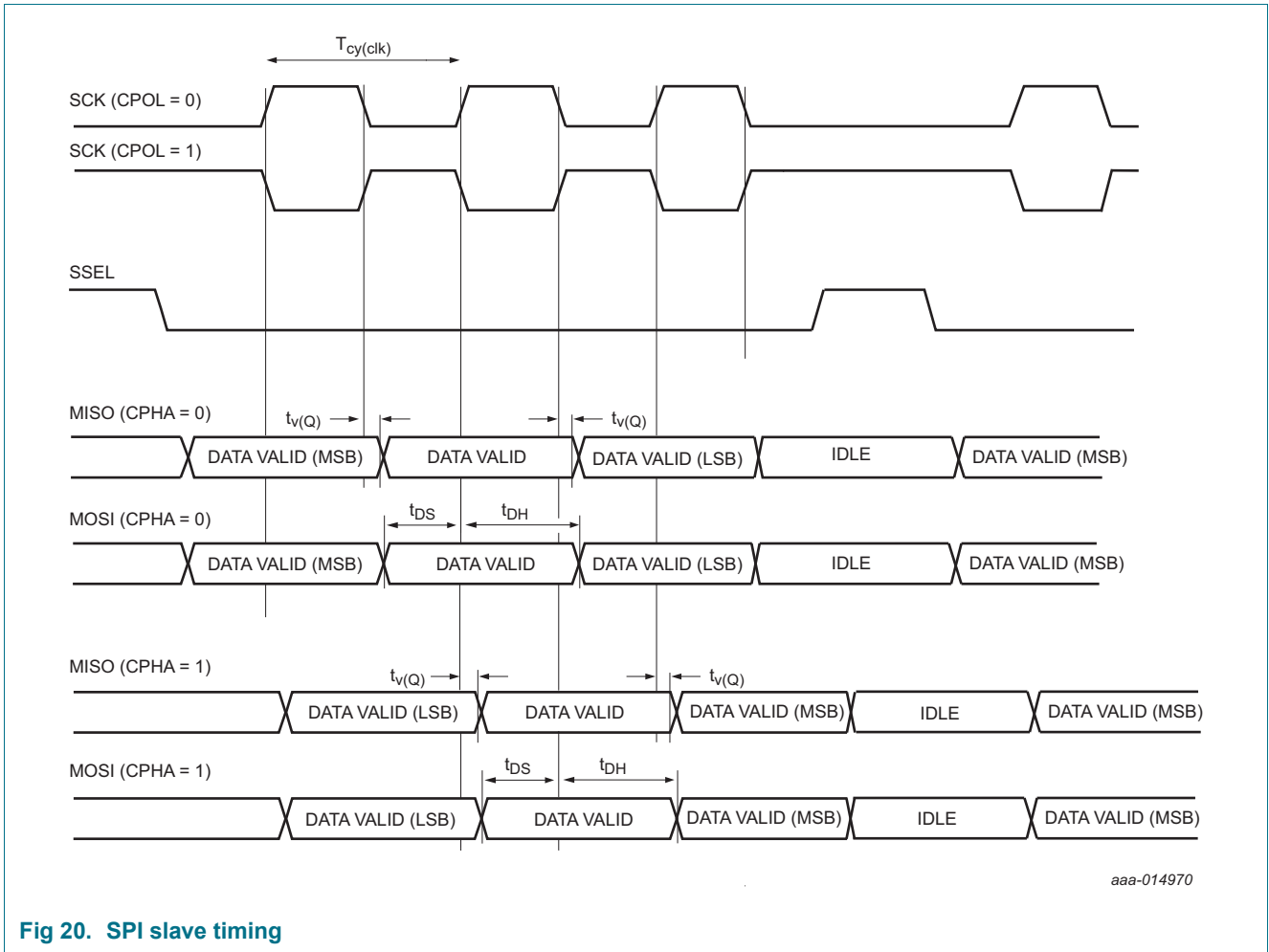

Fig 20. SPI slave timing

11.14 USART interface

The actual USART bit rate depends on the delays introduced by the external trace, the external device, system clock (CCLK), and capacitive loading. Excluding delays introduced by external device and PCB, the maximum supported bit rate for USART master and slave synchronous mode is 12 Mbit/s. Excluding delays introduced by external device and PCB, the maximum supported bit rate for USART master and slave asynchronous mode is 10 Mbit/s.

Table 38. USART dynamic characteristics^[1]

$T_{amb} = -40\text{ }^{\circ}\text{C to }105\text{ }^{\circ}\text{C}$; $T_{amb} = -40\text{ }^{\circ}\text{C to }105\text{ }^{\circ}\text{C}$; $1.8\text{ V} \leq VDD_MAIN \leq 3.6\text{ V}$; $1.8\text{ V} \leq VDDIO_1 \leq 3.6\text{ V}$; $1.08\text{ V} \leq VDDIO_2 \leq 3.6\text{ V}$; $C_L = 10\text{ pF}$ balanced loading on all pins; Input slew = 1 ns, SLEW setting = fast-mode for all pins; Parameters sampled at the 50% level of the rising or falling edge.

Symbol	Parameter	Conditions	Min	Typ	Max	Unit
USART master (in synchronous mode)						
$t_{su(D)}$	data input set-up time	CPU clock < 100 MHz	30	-	-	ns
		100 MHz ≤ CPU clock ≤ 150 MHz	20	-	-	ns
$t_{h(D)}$	data input hold time		0	-	-	ns
$t_{v(Q)}$	data output valid time		0	-	10	ns
USART slave (in synchronous mode)						
$t_{su(D)}$	data input set-up time		10	-	-	ns
$t_{h(D)}$	data input hold time		0	-	-	ns
$t_{v(Q)}$	data output valid time	CPU clock < 100 MHz	0	-	35	ns
		100 MHz ≤ CPU clock ≤ 150 MHz	0	-	20	ns

[1] Based on simulated values. Not tested in production.

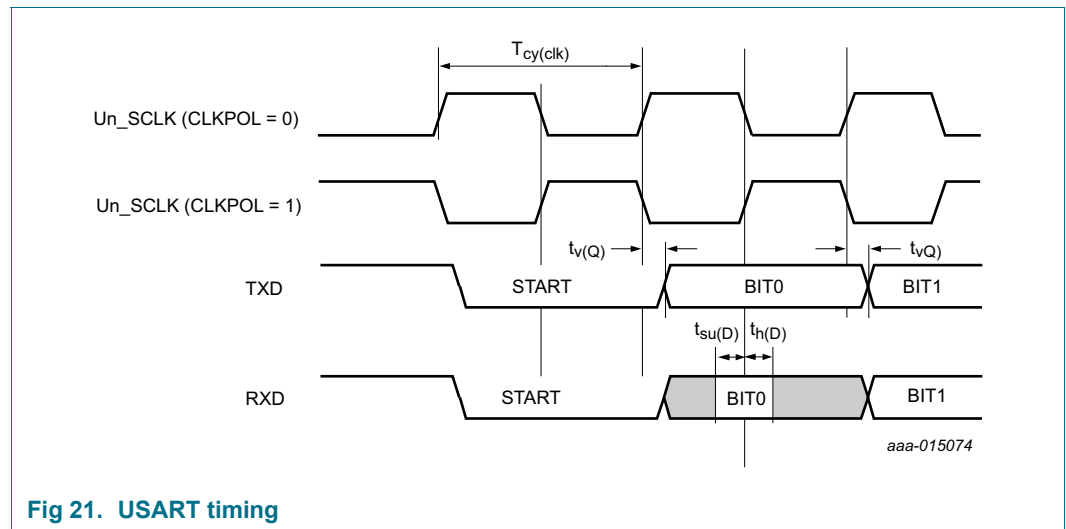

Fig 21. USART timing

11.15 FlexSPI flash interface

Table 39. Dynamic characteristics: FlexSPI flash interface [1]

$T_{amb} = -40\text{ }^{\circ}\text{C}$ to $+105\text{ }^{\circ}\text{C}$, $1.8\text{ V} \leq VDD_MAIN \leq 3.6\text{ V}$; $1.8\text{ V} \leq VDDIO_1 \leq 3.6\text{ V}$; $1.08\text{ V} \leq VDDIO_2 \leq 3.6\text{ V}$; $C_L = 10\text{ pF}$ balanced loading on all pins; Full Drive Mode on all pins, Input slew = 1 ns, SLEW setting = standard mode for all pins; Parameters sampled at the 50% level of the rising or falling edge.

Symbol	Parameter	Conditions	Min	Typ	Max	Unit
SDR Mode						
f_{clk}	clock frequency	Transmit	-	-	100	MHz
		RX clock source = 0	-	-	100	MHz
		RX clock source = 3	-	-	100	MHz
t_{DS}	data set-up time	RX clock source = 0 (internal dummy read strobe and loopbacked internally)	6	-	-	ns
		source = 3 (external DQS, Flash provides read strobe)	2	-	-	ns
t_{DH}	data hold time	RX clock source = 0 (internal dummy read strobe and loopbacked internally)	0	-	-	ns
		source = 3 (external DQS, Flash provides read strobe)	0	-	-	ns
$t_{V(Q)}$	data output valid time		0	-	4	ns
DDR Mode (with and without DQS)						
f_{clk}	clock frequency	Transmit	-	-	75[2]	MHz
		RX clock source = 0	-	-	50	MHz
		RX clock source = 3, with external DQS.	-	-	50	MHz
t_{DS}	data set-up time	RX clock source = 0 (internal dummy read strobe and loopbacked internally)	12	-	-	ns
		source = 3 (external DQS, Flash provides read strobe)	3	-	-	ns
t_{DH}	data hold time	RX clock source = 0 (internal dummy read strobe and loopbacked internally)	0	-	-	ns
		source = 3 (external DQS, Flash provides read strobe)	0	-	-	ns
$t_{V(Q)}$	data output valid time		0	-	4	ns

[1] Based on simulation; not tested in production.

[2] DLLACR register [6:3] = 8, MISCCR2 register [1:0] = 2.

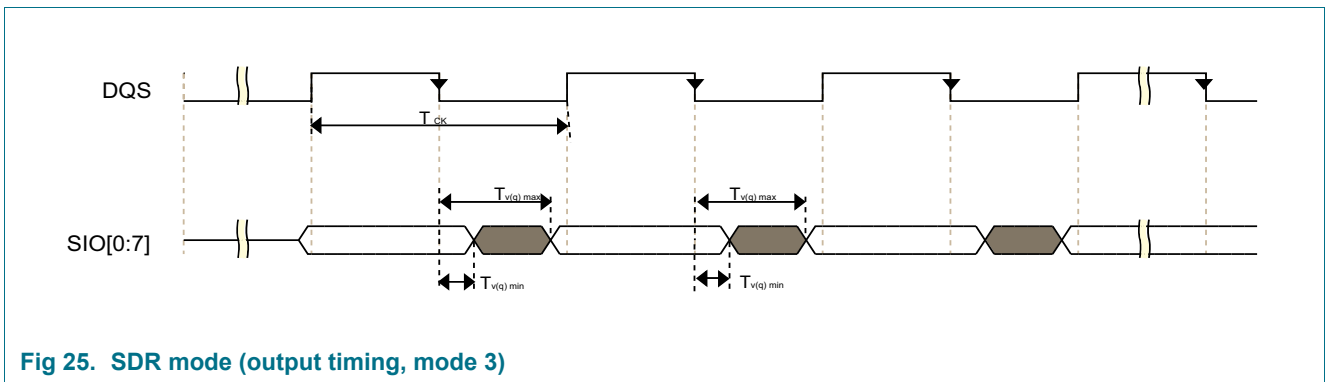
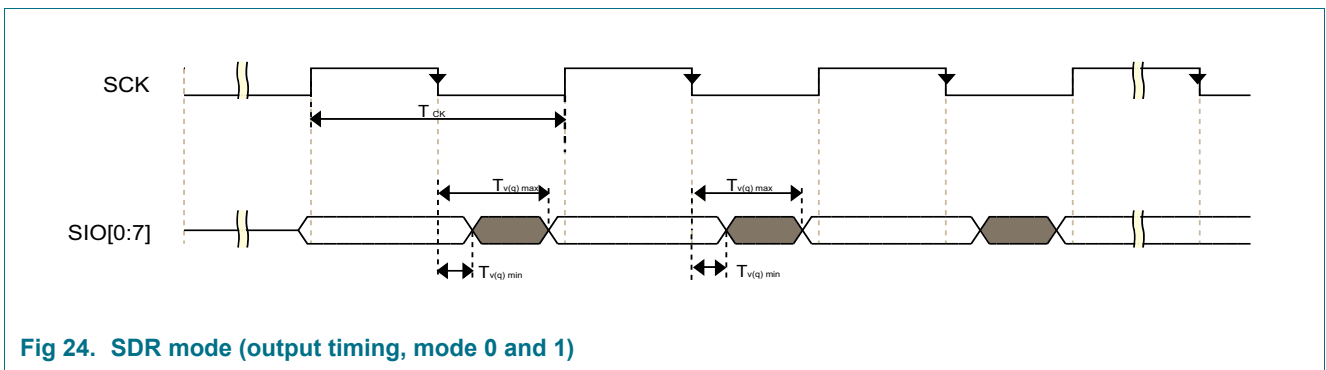
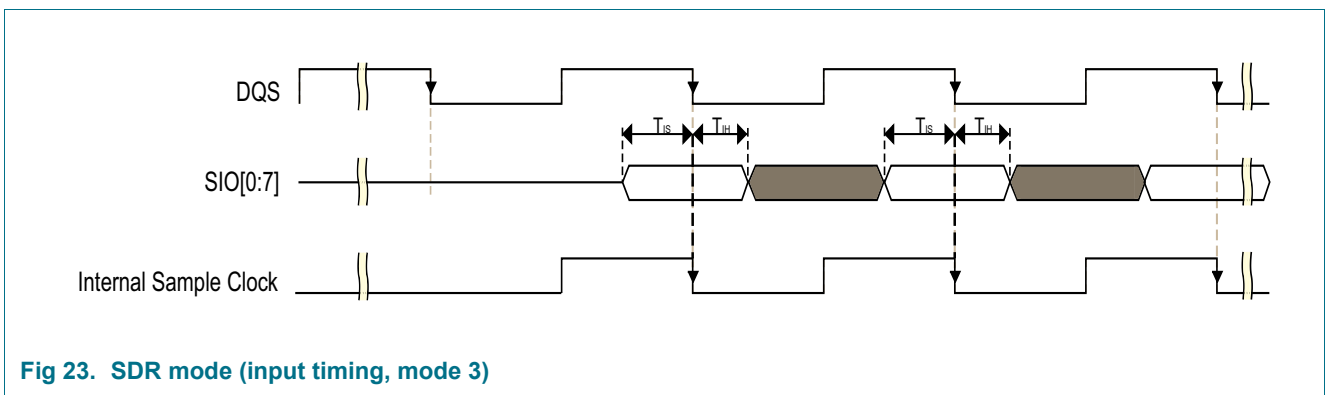
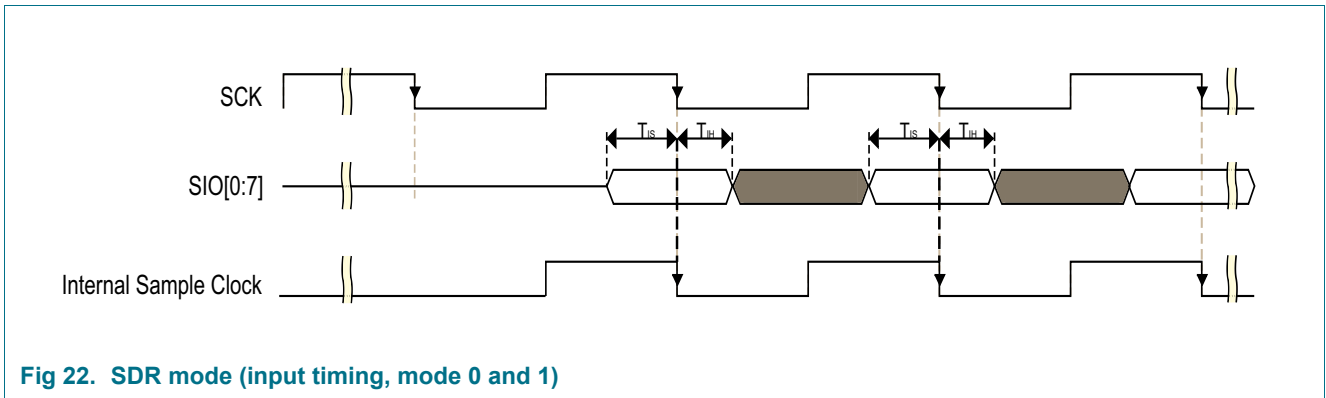

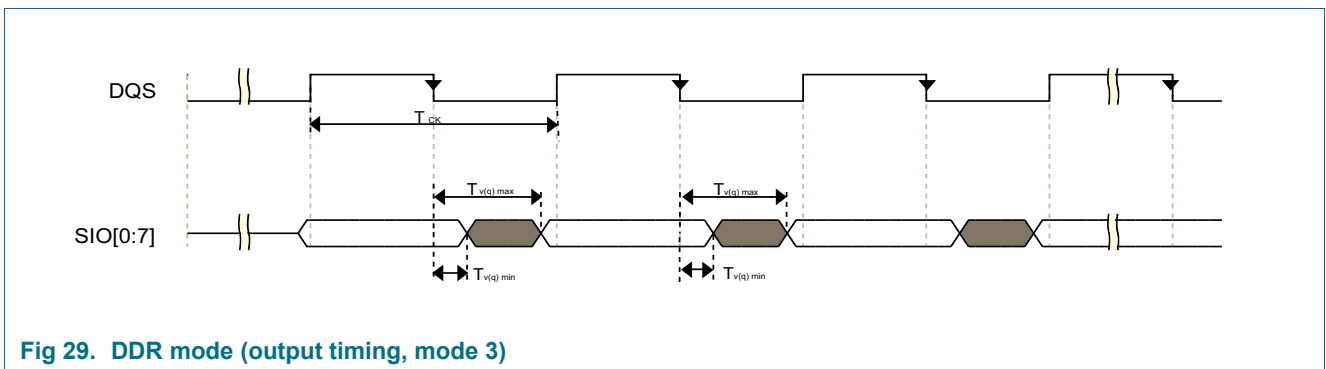
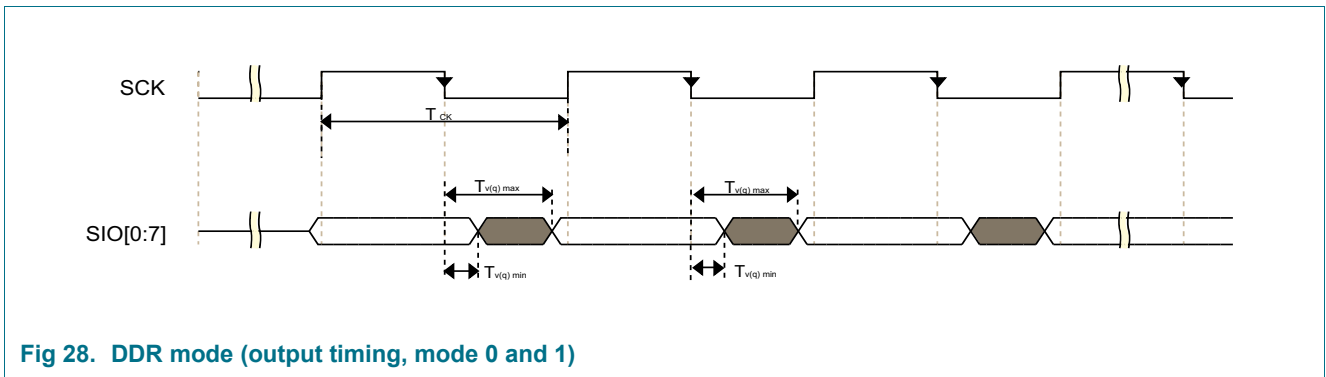
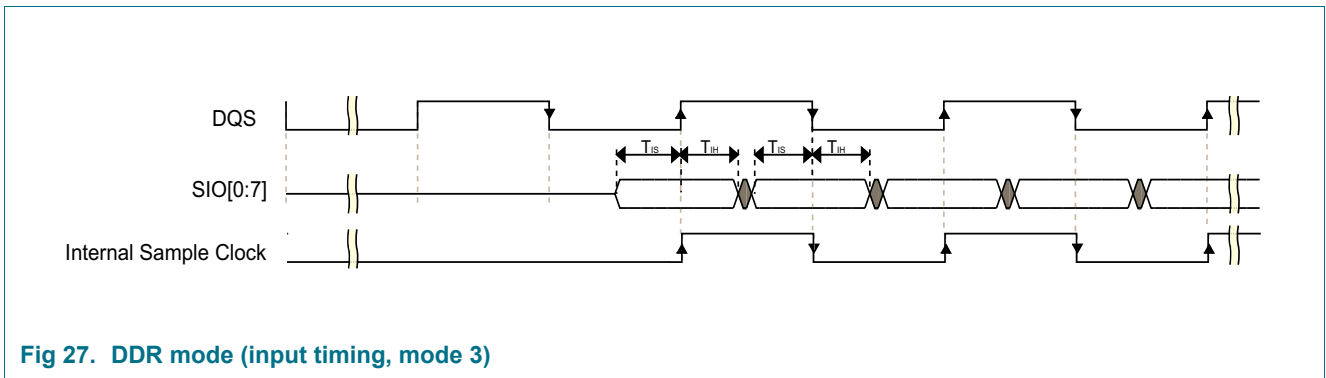
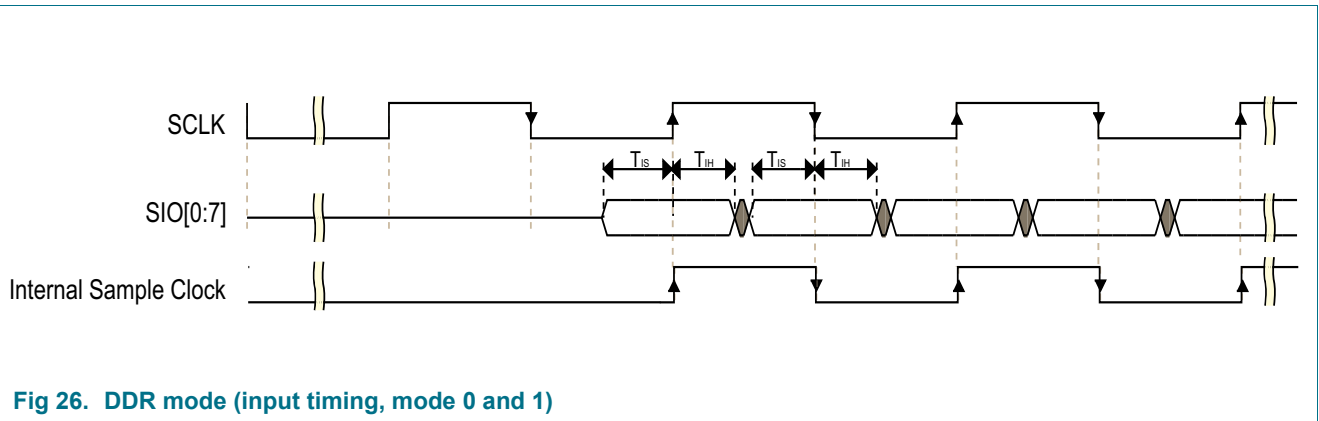

11.16 DMIC subsystem

Table 40. Dynamic characteristics^[1]

$T_{amb} = -40^{\circ}\text{C}$ to 105°C ; $1.8\text{ V} \leq VDD_MAIN \leq 3.6\text{ V}$; $1.8\text{ V} \leq VDDIO_1 \leq 3.6\text{ V}$; $1.08\text{ V} \leq VDDIO_2 \leq 3.6\text{ V}$; $C_L = 10\text{ pF}$ balanced loading on all pins; Input slew = 1 ns , SLEW set to standard mode for all pins; Bypass bit = 0 (PDM data in bypass mode); Parameters sampled at the 50% level of the rising or falling edge

Symbol	Parameter	Conditions	Min	Typ	Max	Unit
t_{DS}	data set-up time	CPU clock < 100 MHz	40	-	-	ns
		$100\text{ MHz} \leq \text{CPU clock} \leq 150\text{ MHz}$	25	-	-	ns
t_{DH}	data hold time		0	-	-	ns

[1] Based on simulated values. Not tested in production.

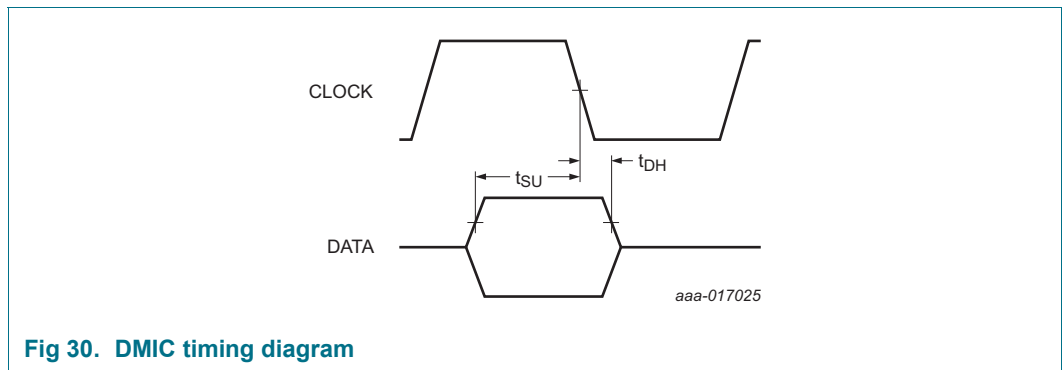

Fig 30. DMIC timing diagram

11.17 SCTimer/PWM output timing

Table 41. SCTimer/PWM output dynamic characteristics

$T_{amb} = -40^{\circ}\text{C}$ to $+105^{\circ}\text{C}$, $1.8\text{ V} \leq VDD_MAIN \leq 3.6\text{ V}$; $1.8\text{ V} \leq VDDIO_1 \leq 3.6\text{ V}$; $1.08\text{ V} \leq VDDIO_2 \leq 3.6\text{ V}$; $C_L = 10\text{ pF}$. Simulated skew (over process, voltage, and temperature) of any two SCT fixed-pin output signals; sampled at the 50% level of the rising or falling edge; based on simulated values. Not tested in production.

Symbol	Parameter	Conditions	Min	Typ	Max	Unit
$t_{sk(o)}$	output skew time	CPU clock < 100 MHz	0	-	15	ns
		$100\text{ MHz} \leq \text{CPU clock} \leq 150\text{ MHz}$	0	-	11	ns

11.18 FlexPWM output timing

Table 42. FlexPWM output dynamic characteristics

$T_{amb} = -40\text{ C}$ to $105\text{ C }^{\circ}\text{C}$, $1.8\text{ V} \leq VDD_MAIN \leq 3.6\text{ V}$; $1.8\text{ V} \leq VDDIO_1 \leq 3.6\text{ V}$; $1.08\text{ V} \leq VDDIO_2 \leq 3.6\text{ V}$.

Symbol	Parameter	Conditions	Min	Typ	Max	Unit
pwmp	resolution	FlexPWM Freq = 150 MHz (6.7 ns), Dithering (5-bit resolution)	-	208	-	ns

12. Analog characteristics

12.1 BOD

Brown-out detector to monitor the voltage of VDD_MAIN/VDD_MAIN_PWR and VDD_CORE. If the voltage falls below one of the selected voltages, the BOD asserts an interrupt to the NVIC or issues a reset. Single low threshold detection level (programmable trip low level) is used for either BOD interrupt or BOD reset. Hysteresis control on the BOD is programmable. Please refer to chip Reference Manual for further details on how to program the desired BOD trigger level.

Table 43. BOD static characteristics (VDD_MAIN/VDD_MAIN_PWR)

$T_{amb} = 25\text{ }^{\circ}\text{C}$; based on characterization; not tested in production.

Symbol	Parameter	Conditions	Min	Typ	Max	Unit
V _{th}	threshold voltage (TRIGLVL)		-	1.75	-	V
			-	1.80	-	V
			-	1.90	-	V
			-	2.00	-	V
			-	2.10	-	V
			-	2.20	-	V
			-	2.30	-	V
			-	2.40	-	V
			-	2.50	-	V
			-	2.60	-	V
			-	2.70	-	V
			-	2.80	-	V
			-	2.90	-	V
			-	3.00	-	V
			-	3.10	-	V
	-	3.20	-	V		
	-	3.30	-	V		

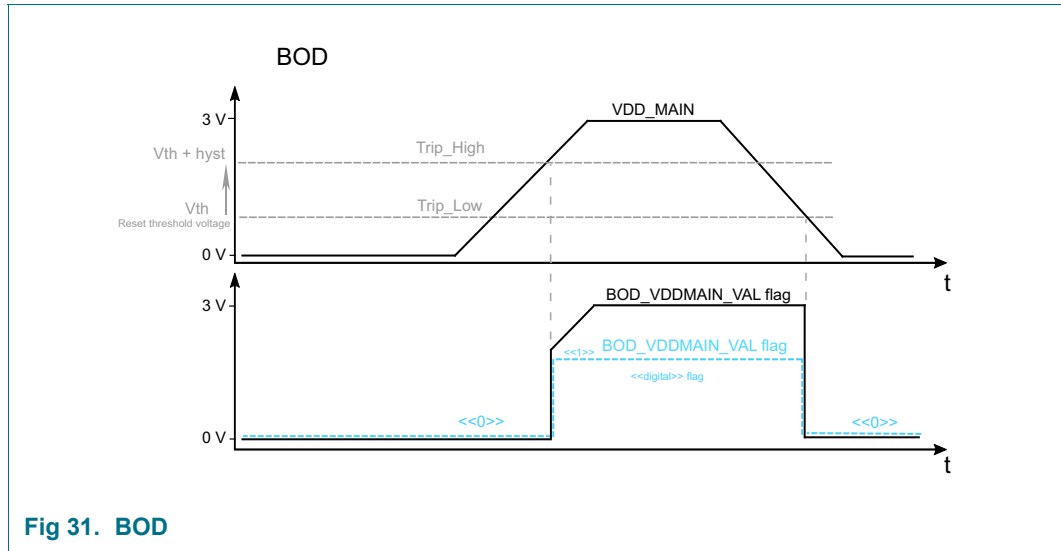

Fig 31. BOD

Table 44. BOD static characteristics (VDD_CORE)

T_{amb} = 25 °C; based on characterization; not tested in production.

Symbol	Parameter	Conditions	Min	Typ	Max	Unit
V _{th}	threshold voltage (TRIGLVL)		-	0.90	-	V
			-	0.95	-	V

12.2 16-bit ADC characteristics

Table 45. 16-bit ADC static characteristics^[9]

T_{amb} = -40 °C to +105 °C; V_{DDA} = 1.8 V to 3.6 V; ADC calibrated at T = 25 °C.

Symbol	Parameter	Conditions	Min ^[2]	Typ ^[2]	Max ^[2]	Unit
V _{IA}	analog input voltage		0	-	V _{DDA}	V
C _{ia}	input capacitance		-	4	-	pF
f _{clk(ADC)}	ADC input clock frequency	Low Power Mode (PWRSEL=00)	4		24	MHz
		High Speed Mode (PWRSEL=11)	4		60	MHz
f _s	sampling frequency	12-bit, MODE=0. ADCK =60MHz, AVG=1,STS=3,PWRSEL=3	-	-	3.2	Msamples/s
		16-bit, MODE=1. ADCK =48MHz, AVG=1,STS=3,PWRSEL=3	-	-	2.0	Msamples/s
E _D	differential linearity error	16-bit differential mode, CTYPE = 2	[1][2][3] -0.94	-0.5/+0.6	5.58	LSB
		16-bit single ended mode, CTYPE = 0	[1][2][3] -2.23	-1/+2.6	4.82	LSB
E _{L(adj)}	integral non-linearity	16-bit differential mode, CTYPE = 2	[1][2][4] -20.96	+/-2.0	17.01	LSB
		16-bit single ended mode, CTYPE = 0	[1][2][4] -7.51	+/-2.8	8.96	LSB
E _O	offset error	Calibrated, 16-bit single ended mode VDDA = VREFP = 3 V	[1][5] -	1	-	LSB
V _{err(FS)}	full-scale error voltage	Calibrated, 16-bit single ended mode VDDA = VREFP = 3 V	[1][6] -	11	-	LSB
E _D	differential linearity error	12-bit differential mode, CTYPE = 2	[1][2][3] -1	-1/+2	3.01	LSB
		12-bit single ended mode, CTYPE = 0	[1][2][3] -1	-1/+0.6	1.6	LSB

Table 45. 16-bit ADC static characteristics^[9] ...continued

$T_{amb} = -40\text{ °C to }+105\text{ °C}$; $V_{DDA} = 1.8\text{ V to }3.6\text{ V}$; ADC calibrated at $T = 25\text{ °C}$.

Symbol	Parameter	Conditions	Min ^[2]	Typ ^[2]	Max ^[2]	Unit	
E _{L(adj)}	integral non-linearity	12-bit differential mode, CTYPE = 2	^{[1][2][4]}	-2.93	+/-2.0	2.48	LSB
		12-bit single ended mode, CTYPE = 0	^{[1][2][4]}	-1.01	-1/+0.6	1.13	LSB
E _O	offset error	Calibrated, 12-bit single ended mode VDDA = VREFP = 3 V	^{[1][5]}	-	0.065	-	LSB
V _{err(FS)}	full-scale error voltage	Calibrated, 12-bit single ended mode VDDA = VREFP = 3 V	^{[1][6]}	-	0.5	-	LSB
ENOB	[L:] Effective number of bits	16-bit differential mode, CTYPE = 2	^[7]	-	13.2	-	bits
		16-bit single ended mode, CTYPE = 0,1	^[7]	-	12.5	-	bits
		16-bit differential mode, CTYPE = 2	^[8]	-	12.4	-	bits
		16-bit single ended mode, CTYPE = 0,1	^[8]	-	11.8	-	bits
		12-bit differential mode, CTYPE = 2	^[7]	-	11.87	-	bits
		12-bit single ended mode, CTYPE = 0,1	^[7]	-	11.28	-	bits
		12-bit differential mode, CTYPE = 2	^[8]	-	10.12	-	bits
		12-bit single ended mode, CTYPE = 0,1	^[8]	-	10.01	-	bits
THD	[L:] Total Harmonic Distortion	16-bit differential mode, CTYPE = 2	^[7]	-	92	-	dB
		16-bit single ended mode, CTYPE = 0,1	^[7]	-	88.1	-	dB
		16-bit differential mode, CTYPE = 2	^[8]	-	88.8	-	dB
		16-bit single ended mode, CTYPE = 0,1	^[8]	-	80.8	-	dB
		12-bit differential mode, CTYPE = 2	^[7]	-	87.4	-	dB
		12-bit single ended mode, CTYPE = 0,1	^[7]	-	80.4	-	dB
		12-bit differential mode, CTYPE = 2	^[8]	-	87.3	-	dB
		12-bit single ended mode, CTYPE = 0,1	^[8]	-	81.5	-	dB
SFDR	[L:] Spurious Free Dynamic Range	16-bit differential mode, CTYPE = 2	^[7]	-	94.6	-	dB
		16-bit single ended mode, CTYPE = 0,1	^[7]	-	89.9	-	dB
		16-bit differential mode, CTYPE = 2	^[8]	-	93.7	-	dB
		16-bit single ended mode, CTYPE = 0,1	^[8]	-	88.4	-	dB
		12-bit differential mode, CTYPE = 2	^[7]	-	62.2	-	dB
		12-bit single ended mode, CTYPE = 0,1	^[7]	-	62.2	-	dB
		12-bit differential mode, CTYPE = 2	^[8]	-	68.2	-	dB
		12-bit single ended mode, CTYPE = 0,1	^[8]	-	68.2	-	dB

Table 45. 16-bit ADC static characteristics^[9] ...continued

$T_{amb} = -40\text{ }^{\circ}\text{C}$ to $+105\text{ }^{\circ}\text{C}$; $V_{DDA} = 1.8\text{ V}$ to 3.6 V ; ADC calibrated at $T = 25\text{ }^{\circ}\text{C}$.

Symbol	Parameter	Conditions	Min ^[2]	Typ ^[2]	Max ^[2]	Unit	
SNR	Signal to Noise Ratio	16-bit differential mode, CTYPE = 2	[7]	-	81.5	-	dB
		16-bit single ended mode, CTYPE = 0,1	[7]	-	77.6	-	dB
		16-bit differential mode, CTYPE = 2	[8]	-	76.2	-	dB
		16-bit single ended mode, CTYPE = 0,1	[8]	-	73.1	-	dB
		12-bit differential mode, CTYPE = 2	[7]	-	57.1	-	dB
		12-bit single ended mode, CTYPE = 0,1	[7]	-	56.9	-	dB
		12-bit differential mode, CTYPE = 2	[8]	-	62.8	-	dB
		12-bit single ended mode, CTYPE = 0,1	[8]	-	62.1	-	dB

- [1] Linear data collected using a linear histogram technique.
- [2] The values listed are typical values ($V_{DDA} = V_{REFP} = 3.0\text{ V}$) and are not guaranteed. Based on characterization. Not tested in production. If V_{REFP} is less than V_{DDA} , then voltage inputs greater than V_{REFP} but less than V_{DDA} are allowed but result in a full scale conversion result.
- [3] The differential linearity error (E_D) is the difference between the actual step width and the ideal step width.
- [4] The integral non-linearity ($E_{L(adj)}$) is the peak difference between the center of the steps of the actual and the ideal transfer curve after appropriate adjustment of gain and offset errors.
- [5] The offset error (E_O) is the absolute difference between the straight line which fits the actual curve and the straight line which fits the ideal curve $V_{DDA} = V_{REFP} = 3.0\text{ V}$.
- [6] The full-scale error voltage or gain error (E_G) is the difference between the straight-line fitting the actual transfer curve after removing offset error, and the straight line which fits the ideal transfer curve.
- [7] Input data is 1kHz sine wave, ADC conversion clock 24 MHz, Power Select = 3, Average setting = 1, STS = 3.
- [8] Input data is 1kHz sine wave, ADC conversion clock 48 MHz, Power Select = 3, Average setting = 1, STS = 3.
- [9] **For 16-bit mode:**
 Sampling frequency = $48\text{ MHz} / (20.5\text{ (conversion cycles)} + \text{sample cycles (STS bit in CMDH register)})$.
 So for minimum sample time of 3 ADCK cycles, the ADC conversion time = $\text{fclk (ADC)} / (20.5 + \text{sample_cycles}) = 48\text{ MHz} / (20.5 + 3.5) = 2.0\text{ Msamples/s}$.
- For 12-bit mode:**
 Sampling frequency = $60\text{ MHz} / (15.5\text{ (conversion cycles)} + \text{sample cycles (STS bit in CMDH register)})$. So for minimum sample time of 3 ADCK cycles, the ADC conversion time = $60 / (15.5 + 3.5) = 3.2\text{ Msamples/s}$.

12.2.1 ADC input resistance

Table 46. ADC input resistance^[1]

$T_{amb} = -40\text{ °C to }+105\text{ °C}$ (Please refer to ADC Inputs Selection & ADC programming table in the Reference Manual).

Symbol	Parameter	Conditions	Min	Typ	Max	Unit
R _i	input resistance	Fast/Muxed ADC Input Channels (PIO0_1, PIO0_10, PIO0_11, PIO0_12, PIO0_15, PIO0_16, PIO01_0, PIO1_7)				
		VDDA = 1.8 V	-	-	1.6	kΩ
		VDDA = 3.0 V	-	-	1.1	kΩ
		Fast/Muxed/Internal ADC Input Channels (PIO1_9)				
		VDDA = 1.8 V	-	-	1.87	kΩ
		VDDA = 3.0 V	-	-	1.1	kΩ
		Standard/Muxed ADC Input Channels (PIO0_23, PIO0_31, PIO1_19, PIO1_20, PIO1_24, PIO2_0)				
		VDDA = 1.8 V	-	-	3.2	kΩ
		VDDA = 3.0 V	-	-	1.8	kΩ
		Fast/Dedicated ADC Input Channels (ADC1IN1A, ADC1IN1B)				
		VDDA = 1.8 V	-	-	0.3	kΩ
		VDDA = 3.0 V	-	-	0.3	kΩ
		Standard/Dedicated ADC Input Channels (ADC0IN4A, ADC0IN5A, ADC0IN5B, ADC1IN4A, ADC1IN5A, ADC1IN5B)				
		VDDA = 1.8 V	-	-	0.3	kΩ
VDDA = 3.0 V	-	-	0.3	kΩ		

[1] Based on simulation, not tested, characterized, or tested in production.

12.3 Temperature sensors

Table 47. Temperature sensors static and dynamic characteristics ^[3]

$1.8\text{ V} \leq VDD_MAIN \leq 3.6\text{ V}$; $1.8\text{ V} \leq VDDIO_1 \leq 3.6\text{ V}$; $1.08\text{ V} \leq VDDIO_2 \leq 3.6\text{ V}$

Symbol	Parameter	Conditions	Min	Typ	Max	Unit
DT _{sen}	sensor temperature accuracy	$T_{amb} = -40\text{ °C to }+105\text{ °C}$ ^[1]	-	+/- 2	+/- 2.5	°C
t _{s(pu)}	power-up settling time	^[2]	-	5	-	μs

[1] Absolute temperature accuracy. Based on characterization, not tested in production.

[2] Typical values are derived from nominal simulation.

[3] To use temperature sensors, the maximum fclk(ADC) frequency is 6 MHz.

12.4 Comparators

Table 48. Comparator characteristics (in always-on domain)

$T_{amb} = -40\text{ }^{\circ}\text{C}$ to $+105\text{ }^{\circ}\text{C}$ unless noted otherwise; $VDDA = ACMP0VREF = 1.8\text{ V}$ to 3.6 V .

Symbol	Parameter	Conditions	Min	Typ ^[1]	Max	Unit
Static characteristics						
I _{DD}	supply current	Low Power Mode	-	2.5	-	μA
		Fast Mode	-	5	-	μA
V _{IC}	common-mode input voltage	Propagation delay; V _{cm_min} = 0.1 V to VDD_MAIN-0.1 V	0	-	VDD_MAIN	V
V _{offset}	offset voltage	Common mode input voltage < VDD_MAIN - 0.2 V	0	-	10	mV
V _{offset}	offset voltage	Common mode input voltage (Range: VDD_MAIN - 0.2 V:VDD_MAIN - 0.1 V)	0	-	20	mV
Dynamic characteristics						
t _{startup}	start-up time	nominal process; VDD_MAIN = 3.3 V; T _{amb} = 25 °C, Max overdrive with reference at mid-supply	-	3.3	-	μs
t _{delay}	propagation delay time Low Power Mode negative input = VDD_MAIN/2	V _{overdrive} = 50 mV	-	3100	-	ns
		V _{overdrive} = max ^[2]	-	900	3000	ns
	propagation delay time Low Power Mode negative input = VDD_MAIN - 0.1 V	V _{overdrive} = 50 mV	-	6000	-	ns
		V _{overdrive} = max ^[2]	-	4400	-	ns
	propagation delay time Low Power Mode negative input = 0.1 V	V _{overdrive} = 50 mV	-	2300	-	ns
		V _{overdrive} = max ^[2]	-	50	200	ns
	propagation delay time High Speed Mode negative input = VDD_MAIN/2	V _{overdrive} = 50 mV	-	520	-	ns
		V _{overdrive} = max ^[2]	-	210	300	ns
	propagation delay time High Speed Mode negative input = VDD_MAIN - 0.1 V	V _{overdrive} = 50 mV	-	1150	-	ns
		V _{overdrive} = max ^[2]	-	790	-	ns
	propagation delay time High Speed Mode negative input = 0.1 V	V _{overdrive} = 50 mV	-	405	-	ns
		V _{overdrive} = max ^[2]	-	40	100	ns

Table 48. Comparator characteristics (in always-on domain) ...continued

$T_{amb} = -40\text{ }^{\circ}\text{C}$ to $+105\text{ }^{\circ}\text{C}$ unless noted otherwise; $VDDA = ACMP0VREF = 1.8\text{ V}$ to 3.6 V .

Symbol	Parameter	Conditions	Min	Typ ^[1]	Max	Unit
V_{hys}	hysteresis voltage (VHYST_P - VHSYT_N)	Common Mode Input Voltages in [VDD_MAIN-300 mV: VDD_MAIN-200 mV] range (See Vin_N in Figure 32)	-	150	300	mV
		Common Mode Input Voltages in [200 mV: Vbat - 300mV] range (See Vin_N in Figure 32)	-	100	200	mV
R_{lad}	ladder resistance	Resistive ladder, Divider ratio programmed with 5-bit control word. Entry point is either PIO1_19 or internal VDD_MAIN	-	1.27	-	M Ω

[1] Characterized on typical samples, not tested in production; $T_{amb} = 25\text{ }^{\circ}\text{C}$

[2] Max is the difference between VDD_MAIN and negative voltage level

Table 49. High-speed comparator and 8-bit DAC characteristics

$T_{amb} = -40\text{ }^{\circ}\text{C}$ to $+105\text{ }^{\circ}\text{C}$ unless noted otherwise; $VDDA = ACMP0VREF = 1.8\text{ V}$ to 3.6 V .

Symbol	Parameter	Conditions	Min	Typ ^[1]	Max	Unit
Static characteristics						
I_{DD}	supply current	Low Power Mode	-	10	-	μA
		Fast Mode	-	200	-	μA
V_{IC}	common-mode input voltage	Propagation delay; $V_{cm_min} = 0.1\text{ V}$ to $VDD_MAIN - 0.1\text{ V}$	0.1	-	$VDD_MAIN - 0.1$	V
V_{offset}	offset voltage	Normal and High Speed mode	-	-	20	mV
Dynamic characteristics						
$t_{startup}$	start-up time	nominal process; $VDD_MAIN = 3.3\text{ V}$; $T_{amb} = 25\text{ }^{\circ}\text{C}$, Max overdrive with reference at mid-supply	-	40	-	μs

Table 49. High-speed comparator and 8-bit DAC characteristics ...continued

$T_{amb} = -40\text{ }^{\circ}\text{C}$ to $+105\text{ }^{\circ}\text{C}$ unless noted otherwise; $V_{DDA} = ACMP0VREF = 1.8\text{ V}$ to 3.6 V .

Symbol	Parameter	Conditions	Min	Typ ^[1]	Max	Unit
t_{delay}	propagation delay time Low Power Mode negative input = VDD_MAIN/2	V_overdrive = 30 mV	-	-	300	ns
		V_overdrive = 30 mV	-	-	400	ns
		V_overdrive = 30 mV	-	-	400	ns
	propagation delay time High Speed Mode negative input = VDD_MAIN/2	V_overdrive = 30 mV	-	-	50	ns
		V_overdrive = 100 mV	-	-	25	ns
	propagation delay time High Speed Mode negative input = VDD_MAIN-0.1 V	V_overdrive = 30 mV	-	-	50	ns
		V_overdrive = 100 mV	-	-	25	ns
	propagation delay time High Speed Mode negative input = 0.1 V	V_overdrive = 30 mV	-	-	50	ns
		V_overdrive = 100 mV	-	-	25	ns
	V_{hys}	hysteresis voltage	(See Vin_N in Figure 32)			
[HYSTCTR] = 1			-	10	-	mV
[HYSTCTR] = 2			-	20	-	mV
[HYSTCTR] = 3				30	-	mV
R_{ladder}	ladder resistance	Resistive ladder				
		Low Power mode		3.6		MΩ
		High Speed mode		0.45		MΩ
I_{DAC8b}	8-bit DAC current	Low Power mode		1		μA
		High Speed mode		10		μA
INL	Integral Non-linearity	Low Power mode	-1		+1	LSB
		High Speed mode	-1		+1	LSB
DNL	Differential Non-linearity	Low Power mode	-1		+1	LSB
		High Speed mode	-1		+1	LSB

[1] Characterized on typical samples, not tested in production; $T_{amb} = 25\text{ }^{\circ}\text{C}$

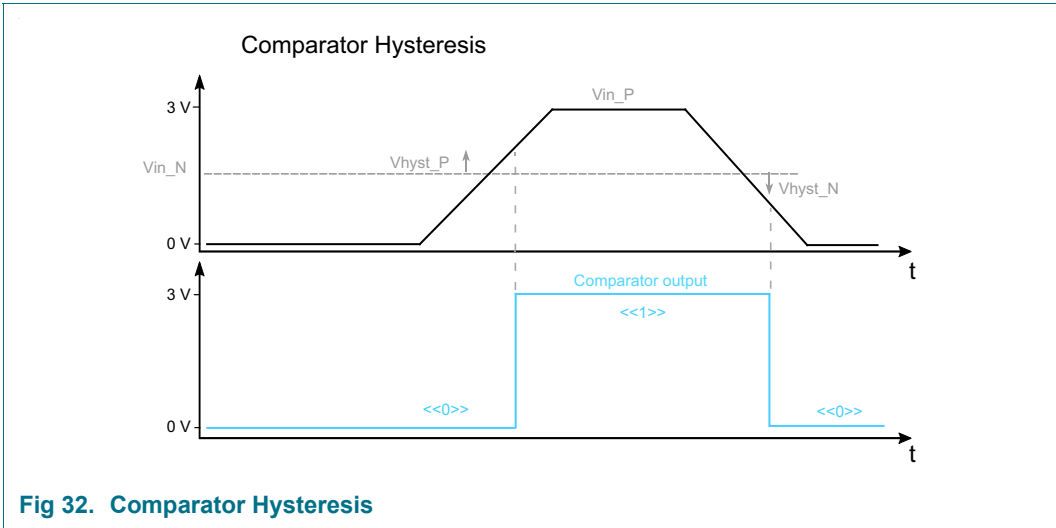

Fig 32. Comparator Hysteresis

12.5 Voltage reference electrical specifications

Table 50. VREF operating requirements

Symbol	Description	Min	Typ	Max	Unit
VDDA	Supply voltage	1.8	3.0	3.6	V
C _L ^[1]	Output load capacitance	130	220	1000	nF

[1] C_L must be connected to VREF_OUT if the VREF_OUT functionality is being used for either an internal or external reference.

Table 51. VREF operating behaviors^[6]

T_{amb} = -40 °C to +105 °C and VDDA = 1.8 V to 3.6 V unless noted otherwise.

Symbol	Description	Min	Typ ^[7]	Max	Unit
Low power bandgap					
V _{vrefo_lpbg} ^{[1] [2]}	Voltage reference output - LP bandgap	0.95	1.0	1.05	V
I _{q_lpbg}	Quiescent current - LP bandgap	-	1.6	-	μA
I _{out_lpbg}	Output current - LP bandgap	-	±10	-	μA
t _{st_lpbg}	Start-up time - LP bandgap	-	6	20	μs
Voltage reference					
V _{vrefo}	Voltage reference output	1.0		2.1 ^[2]	V
V _{step}	Fine trim step	-	0.5 x V _{vrefo} (V)	-	mV
I _q	Quiescent current (active mode)	-	750	-	μA
I _{out}	Output current	±1	-	-	mA
ΔV _{LOAD} ^[4]	Load regulation I _{out} of +/-1mA min	-	100	200	μV/mA
V _{acc} ^[3]	Absolute voltage accuracy (25°C)	-	±1.5	±5	mV
V _{dev} ^[5]	Voltage deviation over temperature (-40°C → 105°C)	-	0.22	0.3	%
V _{dev} ^[5]	Voltage deviation over temperature (-20°C → 70°C)	-	0.15	0.2	%
t _{st}	Start-up time	-		400	μs

[1] See the chip's Reference Manual for the appropriate settings of the VREF Status and Control registers.

[2] V_{vrefo} max is also ≤ VDDA - 0.6 V.

[3] Trimmed value in default configuration (1.2 V).

[4] Load regulation voltage is the difference between the VREF_OUT voltage with no load v.s. voltage with defined load.

[5] (V_{max}-V_{min})/V_{min} for all step of 100mV.

[6] Based on characterization, not tested in production.

[7] Typical silicon, 25°C, VDDA = 3.0 V.

12.6 DAC specifications

Table 52. DAC specifications^[1]

$T_{amb} = -40\text{ }^{\circ}\text{C}$ to $+105\text{ }^{\circ}\text{C}$ and $V_{DDA} = 1.8\text{ V}$ to 3.6 V unless noted otherwise.

Symbol	Description	Min	Typ ^[2]	Max	Unit	Footnotes
V_{DACR}	DAC reference voltage	0.97	-	V_{DDA}	V	The DAC reference can be selected to be V_{DDA} or V_{REFH}
C_L	Output load capacitance	-	50	100	pF	
I_L	Output load current	-1		1	mA	
I_{dd_dac}	DAC operating current - Low-power mode	-	150	200	μA	DAC Enable, LOW POWER MODE. INPUT CODE: 800h no loading
	DAC operating current - Normal mode	-	500	700	μA	DAC Enable, NORMAL POWER MODE. INPUT CODE: 800h no loading
I_{DIS}	DAC disabled current	-	10	-	nA	
DNL	Differential non-linearity	-	± 0.5	± 1	LSB	Calculated through the difference between two successive analog outputs given by two successive digital inputs in a ramp. DAC enable, BUFFER MODE ON, INPUT CODE: 100h to F00h
INL	Integral non-linearity	-	± 1.5	± 3.0	LSB	Calculated non linearity through the difference between the measured output value and the ideal one DAC enable, BUFFER MODE ON, INPUT CODE: 100h to F00h
E_{OFFSET}	OFFSET Error / Temperature OFFSET Error	-	± 0.15	± 0.5	%	DAC enable, BUFFER MODE ON, INPUT CODE: 100h
E_{GAIN}	GAIN Error / Temperature GAIN Error for $V_{ref} < 1.8\text{V}$	-	± 0.6	-	%FSR	DAC enable, BUFFER MODE ON, INPUT CODE: F00h
	GAIN Error / Temperature GAIN Error for $V_{ref} > 1.8\text{V}$	-	± 0.3	-	%FSR	DAC enable, BUFFER MODE ON, INPUT CODE: F00h
T_{CO}	Temperature coefficient offset voltage	-	± 10	-	$\mu\text{V}/^{\circ}\text{C}$	
T_{GE}	Temperature coefficient gain error	-	10	-	ppm of FSR/ $^{\circ}\text{C}$	
SR_{LP}	Slew Rate - Low-power mode	-	0.5	-	$\text{V}/\mu\text{s}$	Slope measurement during an output code switch in LOW POWER MODE. DAC enable, BUFFER MODE ON, LOW POWER MODE ON, INPUT CODE: 100h to F00h or F00h to 100h.
SR_{HP}	Slew Rate - Normal mode	-	3.0	-	$\text{V}/\mu\text{s}$	Slope measurement during an output code switch in NORMAL POWER MODE. DAC enable, BUFFER MODE ON, NORMAL POWER MODE ON, INPUT CODE: 100h to F00h or F00h to 100h.

Table 52. DAC specifications^[1] ...continued

$T_{amb} = -40\text{ °C to }+105\text{ °C}$ and $V_{DDA} = 1.8\text{ V to }3.6\text{ V}$ unless noted otherwise.

Symbol	Description	Min	Typ ^[2]	Max	Unit	Footnotes
$T_{CCDACLP}$	Code-to-code settling time (low power mode).	-	2	4	μs	DAC Enable, BUFFER MODE ON, LOW POWER MODE. INPUT CODE: BF8h to C08h.
$T_{CCDACHP}$	Code-to-code settling time, (Normal mode).	-	1	2	μs	DAC Enable, BUFFER MODE ON, NORMAL POWER MODE. INPUT CODE: BF8h to C08h
T_{fsLP}	FULL SCALE rising / falling settling time in LOW power mode	-	5	8	μs	Measure the time takes by the DAC to reach and remain in a given band error whose center coincide with the final value in LOW POWER MODE. DAC enable, BUFFER MODE ON, LOW POWER MODE ON, INPUT CODE: 100h to F00h
T_{fsHP}	FULL SCALE rising / falling settling time in NORMAL mode	-	2.5	3	μs	Measure the time takes by the DAC to reach and remain in a given band error whose center coincide with the final value in NORMAL POWER MODE. DAC enable, BUFFER MODE ON, NORMAL POWER MODE ON, INPUT CODE: 100h to F00h
PSRR	Power supply rejection ratio	30	70	-	dB	ΔV_{out} resulting in a ΔV_{in} of 30mV. DAC enable, INPUT CODE: 800h no loading
CT	Cross Talk	-	-	-80	dB	Between DACs, if two DACs are used and share the same VREFH.

[1] Based on characterization, not tested in production.

[2] Typical silicon, 25°C, $V_{DDA} = 3.0\text{ V}$.

12.7 Op-Amp specifications

Table 53. Op-Amp specifications

Characteristic	Min	Typ	Max	Unit	Footnotes
Operating temperature	-40	-	105	C	
Operating voltage	1.8	-	3.6	V	
Supply Current (IOUT=0mA, CL=50pF, low noise)	-	250	-	μA	[1]
Supply Current (IOUT=0mA, CL=0pF, highspeed)	-	450	-	μA	Only connect to SAR ADC internally [1]
Input offset voltage	-5	-	5	mV	[1]
Input offset voltage Temperature Coefficient	-	5	-	$\mu\text{V/C}$	[1]
Input Common Mode Voltage Low	0	-	-	V	
Input Common Mode Voltage High	-	-	V_{DDA}	V	
Input Common Mode Rejection Ratio (Open Loop)	-	80	-	dB	[1]

Table 53. Op-Amp specifications ...continued

Characteristic	Min	Typ	Max	Unit	Footnotes
Power Supply Rejection Ration @ DC	-	80	-	dB	[1]
Slew Rate ($\Delta V_{IN}=1V$, low noise mode)	-	2	-	V/ μ s	50P//10Kohm [1]
Slew Rate ($\Delta V_{IN}=1V$, high speed mode)	-	5.5	-	V/ μ s	Connect to ADC, no load on output [1]
Unity Gain Bandwidth (low noise mode)	-	3	-	MHz	[2]
Unity Gain Bandwidth (high speed mode) CL=0pF	-	15	-	MHz	[2]
DC Open Loop Voltage Gain	-	110	-	dB	[2]
Load Capacitance Driving Capability (Low noise mode)	-	-	50	pF	[2]
Load Capacitance Driving Capability (High speed mode)	-	-	5	pF	[2]
Load resistance	2K	-	-	ohm	[2]
Phase Margin	45	60	-	deg	[1]
Voltage noise density @1kHz input = VDDA/2	-	50	-	nv/sqrt Hz	Low noise mode
Voltage output swing from supply rails (RL = 10 k Ω)	-	150	-	mV	[2]
Settling time (low noise mode)	-	900	-	ns	Setup: Invert gain = 4, input = 10mV, with +/- 150mV settling accuracy. [2]
Settling time (high speed mode)	-	650	-	ns	Setup: Invert gain = 4, input = 10mV, with +/- 150 μ V settling accuracy.[2]
Input Capacitance	-	5	-	pF	[2]
Startup Time (buffer with input 1V)	-	5	-	μ s	[1]

[1] Based on characterization, not tested in production.

[2] Based on simulation, not tested in production.

Table 54. Op-Amp specifications with PGA characteristics

Symbol	Description	Conditions	Min	Typ ^[2]	Max	Unit	Notes
G	Gain ^[3]						
		PGAG = 1	0.95	1	1.05		+/- 5% variation R _{AS} <100 [1]
		PGAG = 2	1.9	2	2.1		
		PGAG = 3	3.8	4	4.2		
		PGAG = 4	7.6	8	8.4		
		PGAG = 5	15.2	16	16.6		
		PGAG = 6	31.2	32.9	34.5		
PGAG = 7	60.6	63.8	67.0				
BW	Input signal bandwidth	low noise mode	-	3/Gain	-	MHz	[1]
		high speed mode	-	15/Gain	-	MHz	[1]

Table 54. Op-Amp specifications with PGA characteristics ...continued

Symbol	Description	Conditions	Min	Typ ^[2]	Max	Unit	Notes
PSRR	Power supply rejection ratio	Gain = 1	-	80	-	dB	V _{DDA} = 3V ±100mV, f _{VDDA} = 50Hz, 60Hz ^[2] , ^[5]
CMRR	Common mode rejection ratio	Gain = 1	-	78.31	-	dB	V _{CM} = 500mVpp
		Gain = 64	-	87.58	-	dB	f _{CM} = 50Hz, 100Hz ^[2] , ^[5]
V _{PP, DIFF}	Maximum differential input signal swing	$\frac{[\min(V_{ref}, V_{DDA} - V_{ref}) - 0.2 - offset] \times Gain}{Gain}$				V	^[4]

[1] Based on characterization, not tested in production.

[2] Typical values assume V_{DDA} = 3.0V, Temp = 25 °C, f_{ADCK} = 12MHz unless otherwise stated.

[3] Gain = 2^{PGAG}

[4] Limit the input signal swing so that the PGA does not saturate during operation. Input signal swing is dependent on the PGA reference voltage and gain setting.

[5] Based on simulation, not tested in production.

13. Application information

13.1 I/O power consumption

I/O pins are contributing to the overall dynamic and static power consumption of the part. If pins are configured as digital inputs, a static current can flow depending on the voltage level at the pin and the setting of the internal pull-up and pull-down resistors. This current can be calculated using the parameters R_{pu} and R_{pd} given in [Table 20](#) for a given input voltage V_I . For pins set to output, the current drive strength is given by parameters I_{OH} and I_{OL} in [Table 20](#), but for calculating the total static current, you also need to consider any external loads connected to the pin.

I/O pins also contribute to the dynamic power consumption when the pins are switching because the V_{DD} supply provides the current to charge and discharge all internal and external capacitive loads connected to the pin in addition to powering the I/O circuitry.

The contribution from the I/O switching current I_{sw} can be calculated as follows for any given switching frequency f_{sw} if the external capacitive load (C_{ext}) is known (see [Table 20](#) for the internal I/O capacitance):

$$I_{sw} = V_{DD} \times f_{sw} \times (C_{io} + C_{ext})$$

13.2 Crystal oscillator

The crystal oscillator has an embedded capacitor bank that can be used as an integrated load capacitor for the crystal oscillators. The capacitor banks on each crystal pin can tune the frequency for crystals with a Capacitive Load (CL) between 6 to 10pF (IEC equivalent). Simple APIs can be used to configure the capacitor banks based on the crystal Capacitive Load (CL) and measured PCB parasitic capacitances on the XIN and XOUT pins.

In the crystal oscillator circuit, only the crystal (XTAL) needs to be connected while the CX1 and CX2 on XTAL32M_P and XTAL32M_N pins can also optionally be connected. No additional capacitance needs to be added to the PCB unless the computation of the required Capacitance Load is less than 20 pF (10 pF equivalent IEC) and greater than 20 pF (10 pF equivalent IEC), in which case, additional capacitance is required. Please refer to the Cap Bank API chapter in the Reference Manual.

In bypass mode, an external clock (maximum frequency of up to 25 MHz) can also be connected to XTAL32M_P if XTAL32M_N is left open. External [0 – VH] square signal can be applied on the XTAL32M_P pin from 0 V to 850 mV.

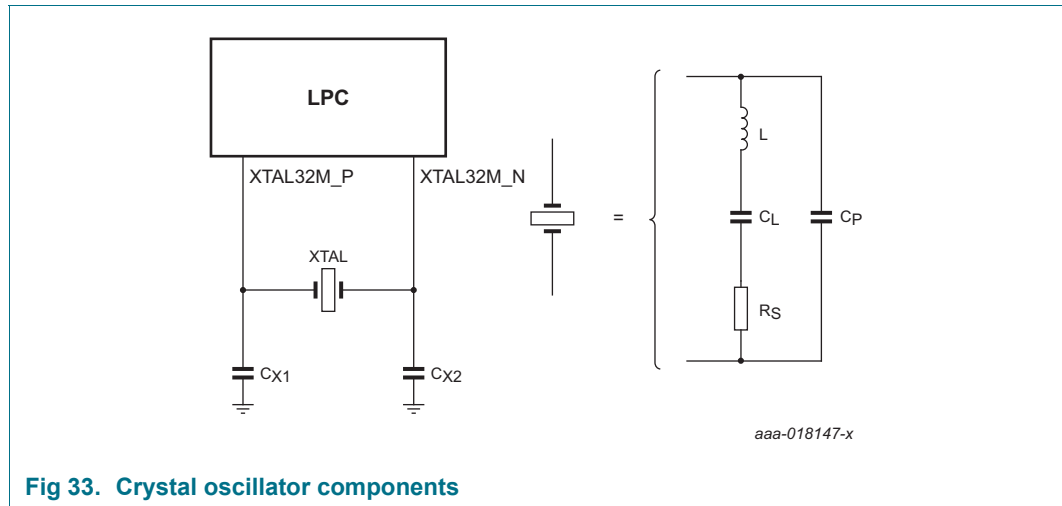

Fig 33. Crystal oscillator components

For best results, it is very critical to select a matching crystal for the on-chip oscillator. Load capacitance (CL), series resistance (RS), and drive level (DL) are important parameters to consider while choosing the crystal.

13.2.1 Crystal Printed Circuit Board (PCB) design guidelines

- Connect the crystal and external load capacitors on the PCB as close as possible to the oscillator input and output pins of the chip.
- The length of traces in the oscillation circuit should be as short as possible and must not cross other signal lines.
- Ensure that the load capacitors have a common ground plane.
- Loops must be made as small as possible to minimize the noise coupled in through the PCB and to keep the parasitics as small as possible.
- Lay out the ground (GND) pattern under crystal unit.
- Do not lay out other signal lines under crystal unit for multi-layered PCB.

13.3 RTC oscillator

The crystal oscillator has an embedded capacitor bank that can be used as an integrated load capacitor for the crystal oscillators. The capacitor banks on each crystal pin can tune the frequency for crystals with a Capacitive Load (CL) between 6 to 10pF (IEC equivalent). Simple APIs can be used to configure the capacitor banks based on the crystal Capacitive Load (CL) and measured PCB parasitic capacitances on the XIN and XOUT pins.

In the crystal oscillator circuit, only the crystal (XTAL) needs to be connected while the CX1 and CX2 on XTAL32K_P and XTAL32K_N pins can also optionally be connected. No additional capacitance needs to be added to the PCB unless the computation of the required Capacitance Load is less than 20 pF (10 pF equivalent IEC) and greater than 20 pF (10 pF equivalent IEC), in which case, additional capacitance is required. Please refer to the Cap Bank API chapter in the Reference Manual.

In bypass mode, an external clock (maximum frequency of up to 100 kHz) can also be connected to XTAL32K_P if XTAL32K_N which is left open. An external [0 – VH] square wave signal can be applied on the XTAL32K_P pin with 1.1 V +/-10%.

A external signal below 1.0 V or above 1.2 V cannot be applied.

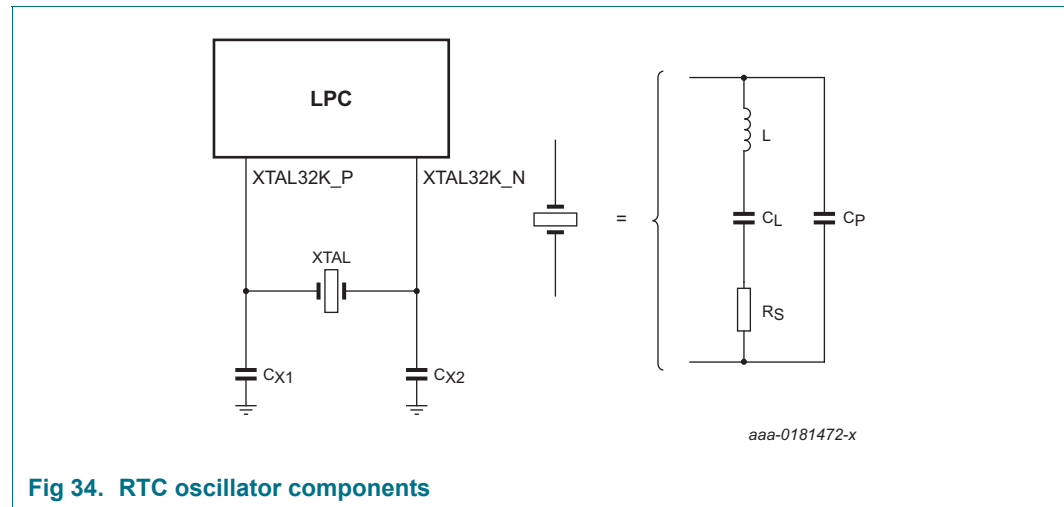

Fig 34. RTC oscillator components

For best results, it is very critical to select a matching crystal for the on-chip oscillator. Load capacitance (CL), series resistance (RS), and drive level (DL) are important parameters to consider while choosing the crystal.

13.3.1 RTC Printed Circuit Board (PCB) design guidelines

- Connect the crystal and external load capacitors on the PCB as close as possible to the oscillator input and output pins of the chip.
- The length of traces in the oscillation circuit should be as short as possible and must not cross other signal lines.
- Ensure that the load capacitors CX1, CX2, and CX3, in case of third overtone crystal usage, have a common ground plane.
- Loops must be made as small as possible to minimize the noise coupled in through the PCB and to keep the parasitics as small as possible.
- Lay out the ground (GND) pattern under crystal unit.
- Do not lay out other signal lines under crystal unit for multi-layered PCB.

13.4 Suggested USB Full-speed interface solutions

The USB device can be connected to the USB as self-powered device (see [Figure 35](#)) or bus-powered device (see [Figure 36](#)).

The USB_VBUS pin is 5 V tolerant only when VDD is applied and at operating voltage level. Therefore, if the USB_VBUS function is connected to the USB connector and the device is self-powered, the USB_VBUS pin must be protected for situations when VDD = 0 V.

If VDD is always at operating level while VBUS = 5 V, the USB_VBUS pin can be connected directly to the VBUS pin on the USB connector. For such USB applications, the internal pull-down on the GPIO/VBUS pad must be enabled on pins P0_22, P1_31, or P1_11 when attaching/de-attaching in the USB application. Enable the internal pull-downs with user software. For USB ISP mode, the internal resistor pull-down is not enabled on the P0_22 or P1_31 pins where the VBUS pin can be floating. USB enumeration may still occur when VBUS is not connected.

For systems where VDD can be 0 V and VBUS is directly applied to the VBUS pin, precautions must be taken to reduce the voltage to below 3.6 V, which is the maximum allowable voltage on the USB_VBUS pin in this case.

One method is to use a voltage divider to connect the USB_VBUS pin to the VBUS on the USB connector. The voltage divider ratio should be such that the USB_VBUS pin is greater than 0.7 VDD to indicate a logic HIGH while below the 3.6 V allowable maximum voltage.

For the following operating conditions:

$$VBUS_{max} = 5.25 \text{ V}$$

$$V_{DD} = 3.6 \text{ V}$$

the voltage divider should provide a reduction of $3.6 \text{ V} / 5.25 \text{ V}$ or $\sim 0.686 \text{ V}$.

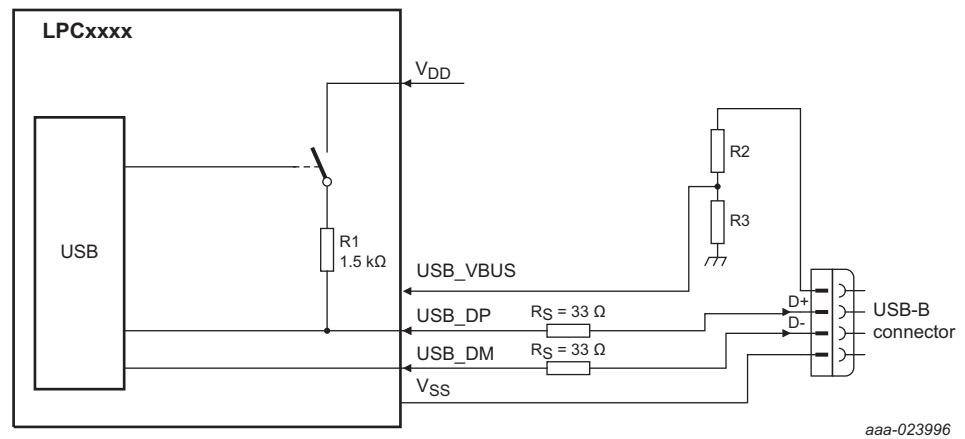
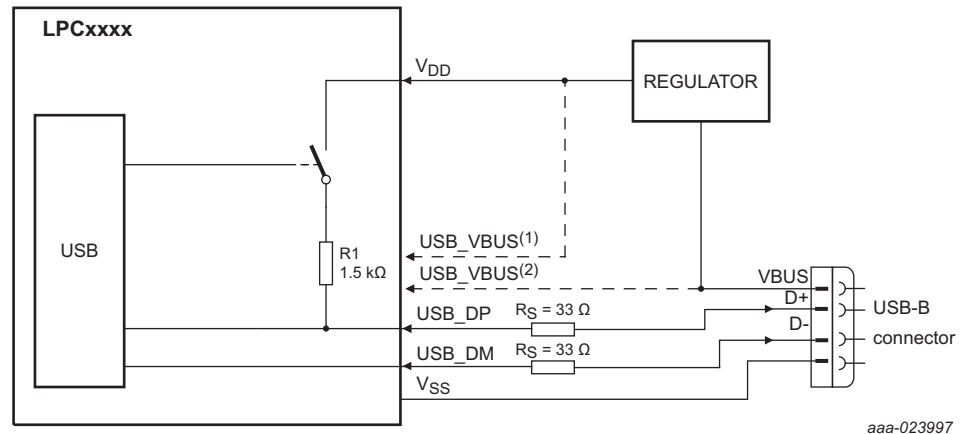

Fig 35. USB interface on a self-powered device where USB_VBUS = 5 V

The internal pull-up ($1.5 \text{ k}\Omega$) can be enabled by setting the DCON bit in the DEVCMDSTAT register to prevent the USB from timing out when there is a significant delay between power-up and handling USB traffic. External circuitry is not required.



Two options exist for connecting VBUS to the USB_VBUS pin:

(1) Connect the regulator output to USB_VBUS. In this case, the USB_VBUS signal is HIGH whenever the part is powered.

(2) Connect the VBUS signal directly from the connector to the USB_VBUS pin. In this case, 5 V are applied to the USB_VBUS pin while the regulator is ramping up to supply VDD. Since the USB_VBUS pin is only 5 V tolerant when VDD is at operating level, this connection can degrade the performance of the part over its lifetime. Simulation shows that lifetime is reduced to 15 years at $T_{amb} = 45\text{ }^{\circ}\text{C}$ and 8 years at $T_{amb} = 55\text{ }^{\circ}\text{C}$ assuming that $USB_VBUS = 5\text{ V}$ is applied continuously while $VDD = 0\text{ V}$.

Fig 36. USB interface on a bus-powered device

14. Package outline

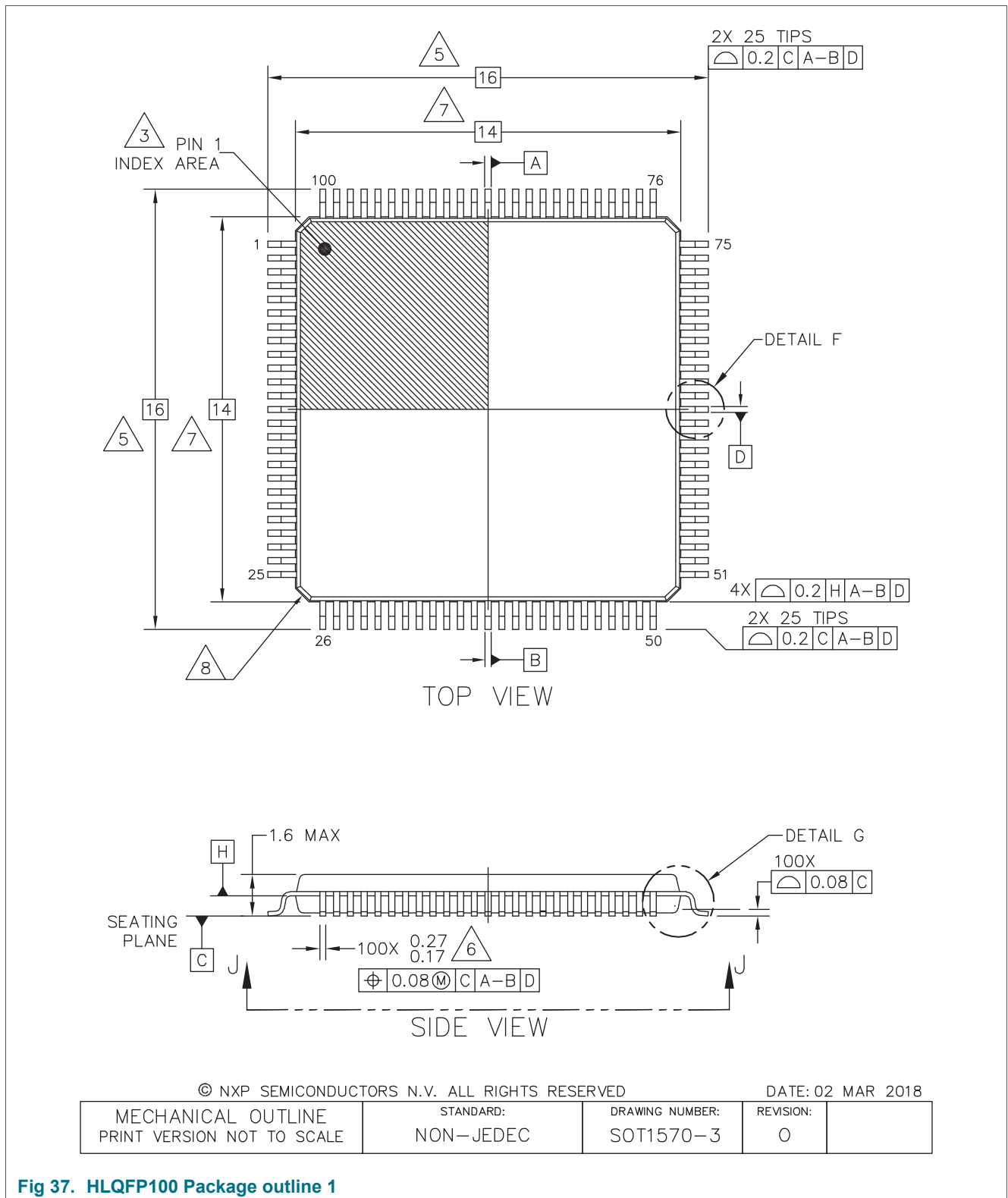
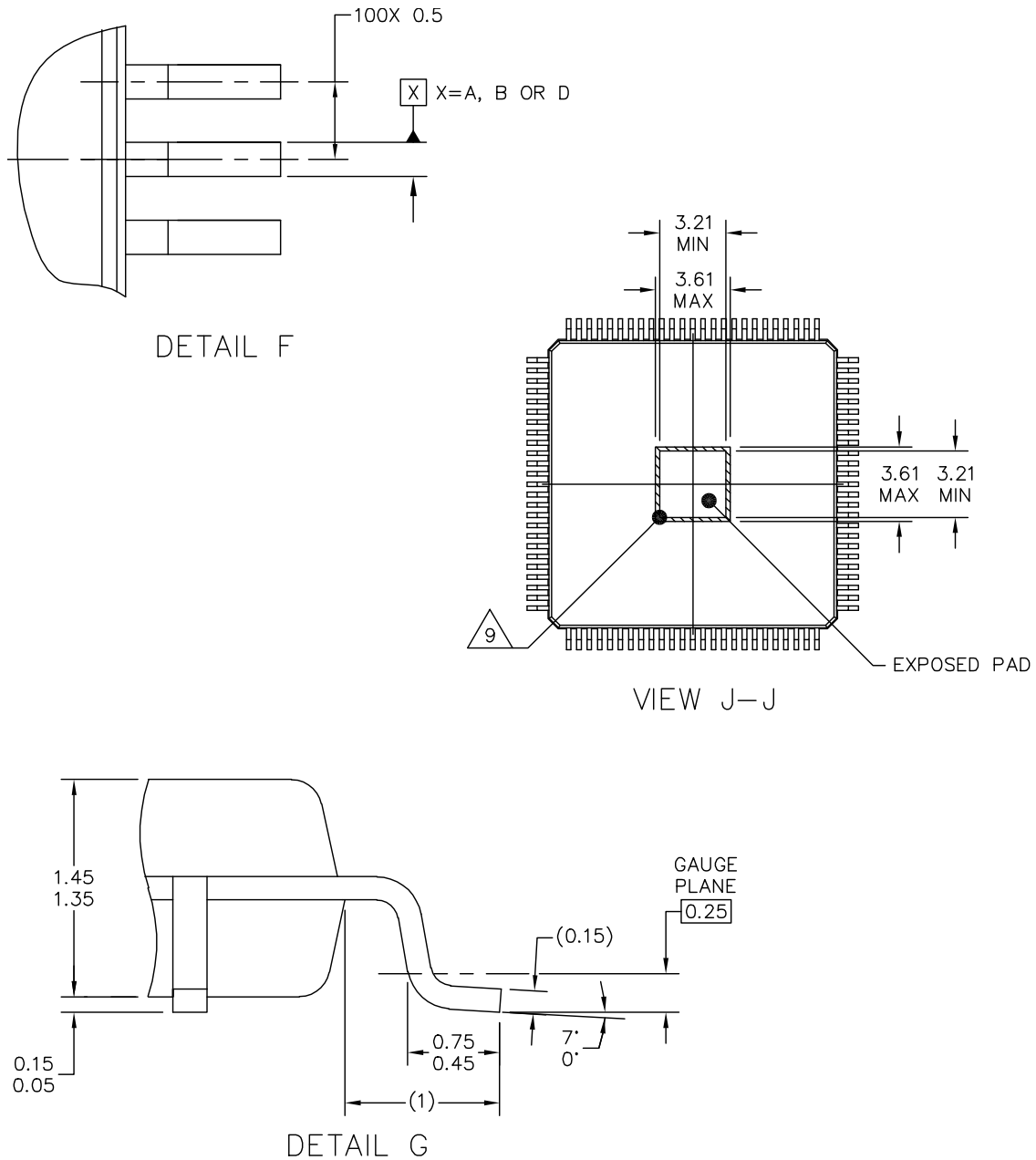

Fig 37. HLQFP100 Package outline 1



© NXP SEMICONDUCTORS N.V. ALL RIGHTS RESERVED

DATE: 02 MAR 2018

MECHANICAL OUTLINE PRINT VERSION NOT TO SCALE	STANDARD: NON-JEDEC	DRAWING NUMBER: SOT1570-3	REVISION: 0	
--	------------------------	------------------------------	----------------	--

Fig 38. HLQFP100 Package outline 2

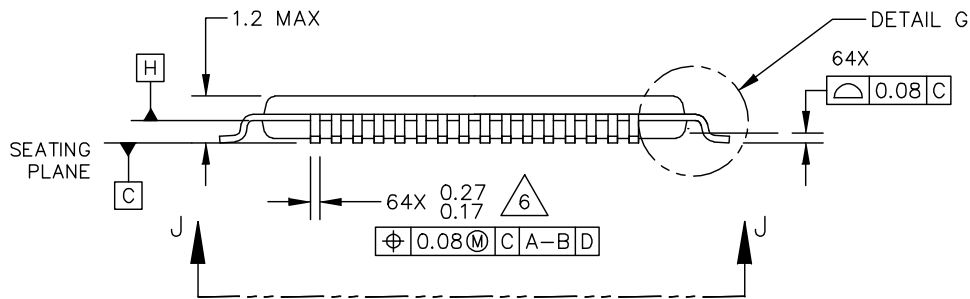
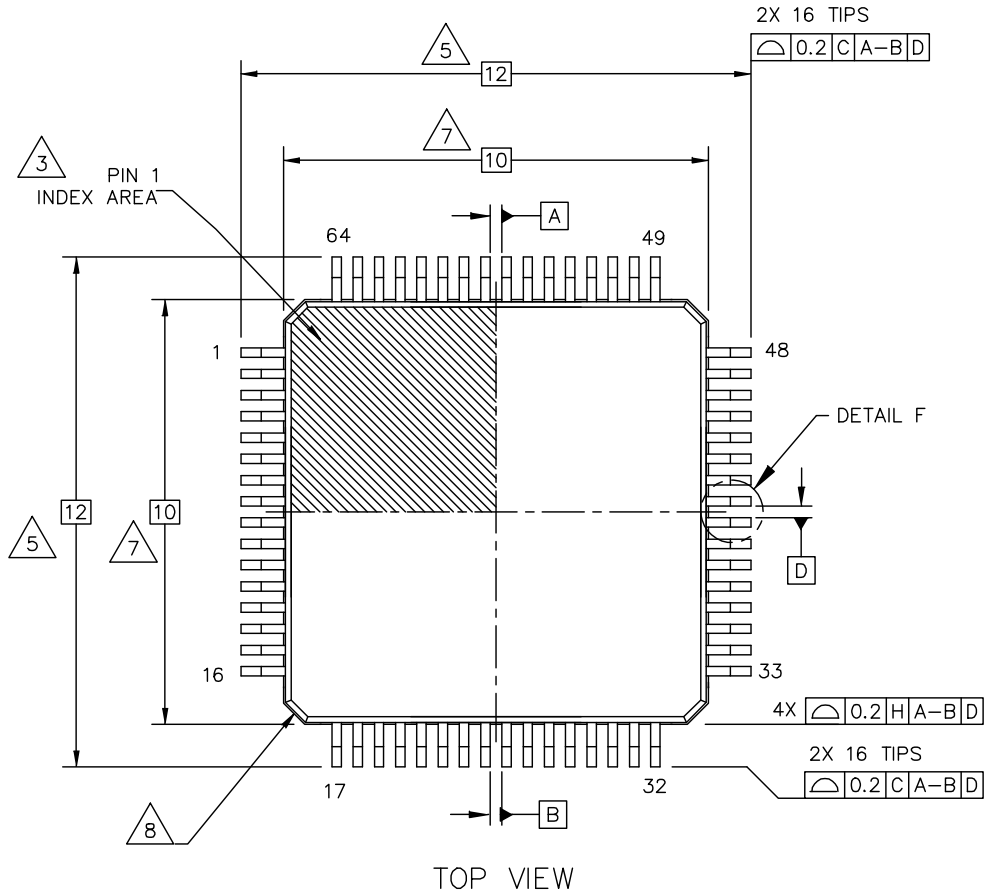

© NXP B.V. ALL RIGHTS RESERVED

DATE: 18 DEC 2018

MECHANICAL OUTLINE PRINT VERSION NOT TO SCALE	STANDARD: NON JEDEC	DRAWING NUMBER: 98ASA01376D	REVISION: 0	
--	------------------------	--------------------------------	----------------	--

Fig 39. HTQFP64 Package outline 1

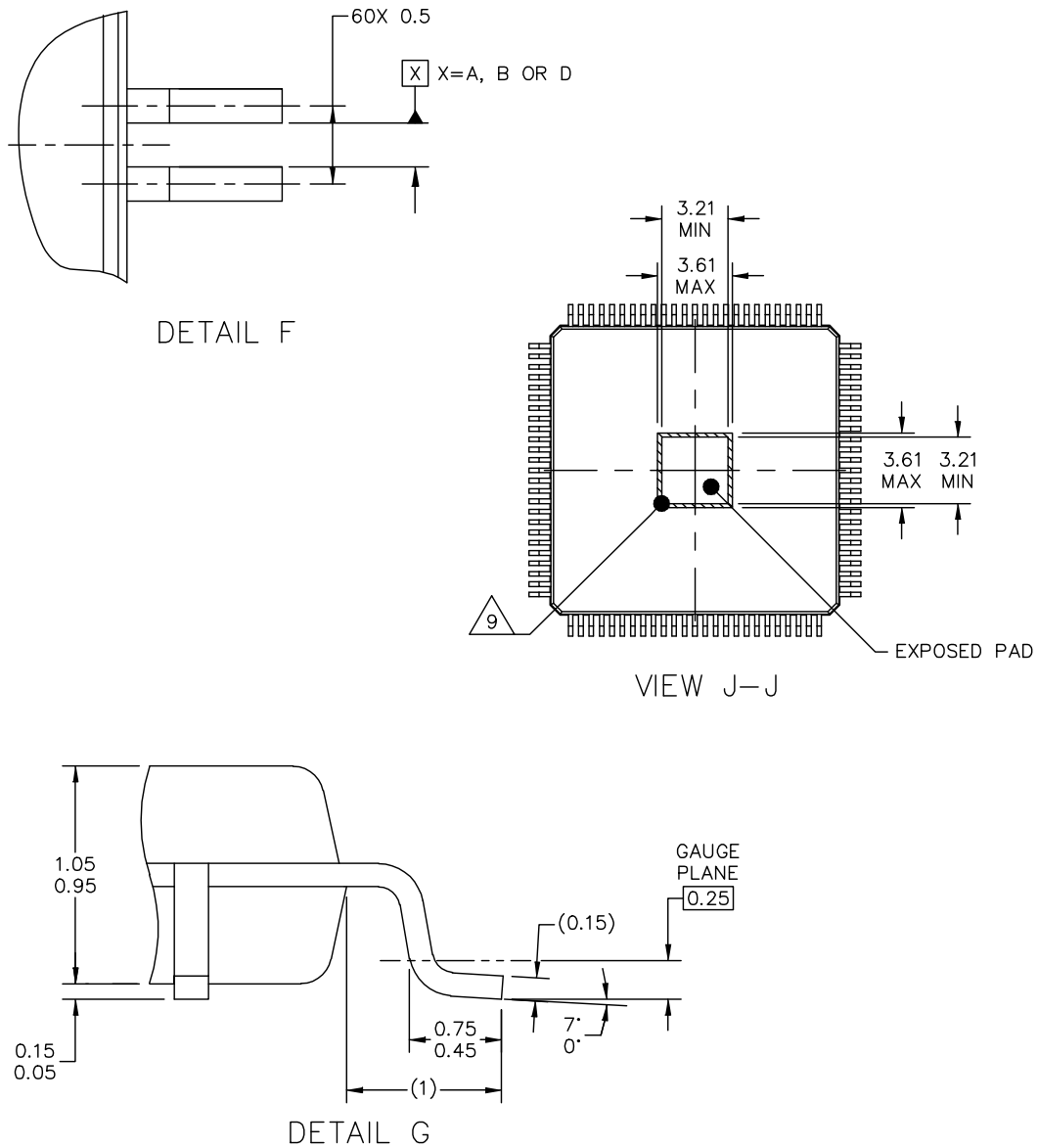

© NXP B.V. ALL RIGHTS RESERVED

DATE: 18 DEC 2018

MECHANICAL OUTLINE PRINT VERSION NOT TO SCALE	STANDARD: NON JEDEC	DRAWING NUMBER: 98ASA01376D	REVISION: 0	
--	------------------------	--------------------------------	----------------	--

Fig 40. HTQFP64 Package outline 2

HVQFN48: plastic thermal enhanced very thin quad flat package; no leads; 48 terminals; body 7 x 7 x 0.85 mm

SOT619-1

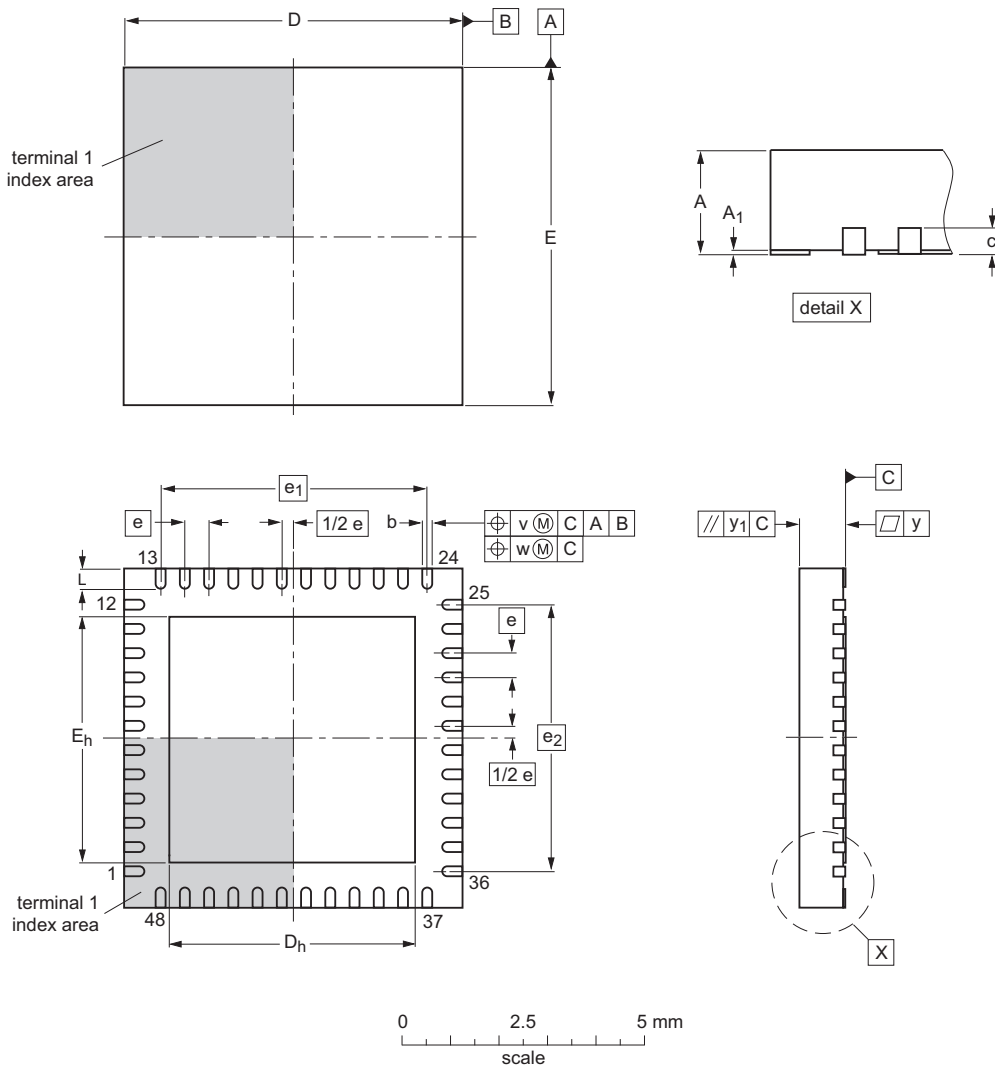

Dimensions (mm are the original dimensions)

Unit ⁽¹⁾	A	A ₁	b	C	D	D _h	E	E _h	e	e ₁	e ₂	L	v	w	y	y ₁
max	1.00	0.05	0.30		7.1	5.25	7.1	5.25				0.5				
mm nom	0.85	0.02	0.21	0.2	7.0	5.10	7.0	5.10	0.5	5.5	5.5	0.4	0.1	0.05	0.05	0.1
min	0.80	0.00	0.18		6.9	4.95	6.9	4.95				0.3				

Note

1. Plastic or metal protrusions of 0.075 mm maximum per side are not included

sot619-1_po

Outline version	References			European projection	Issue date
	IEC	JEDEC	JEITA		
SOT619-1		MO-220			-02-10-18- 12-11-22

Fig 41. HVQFN48 Package outline

15. Soldering

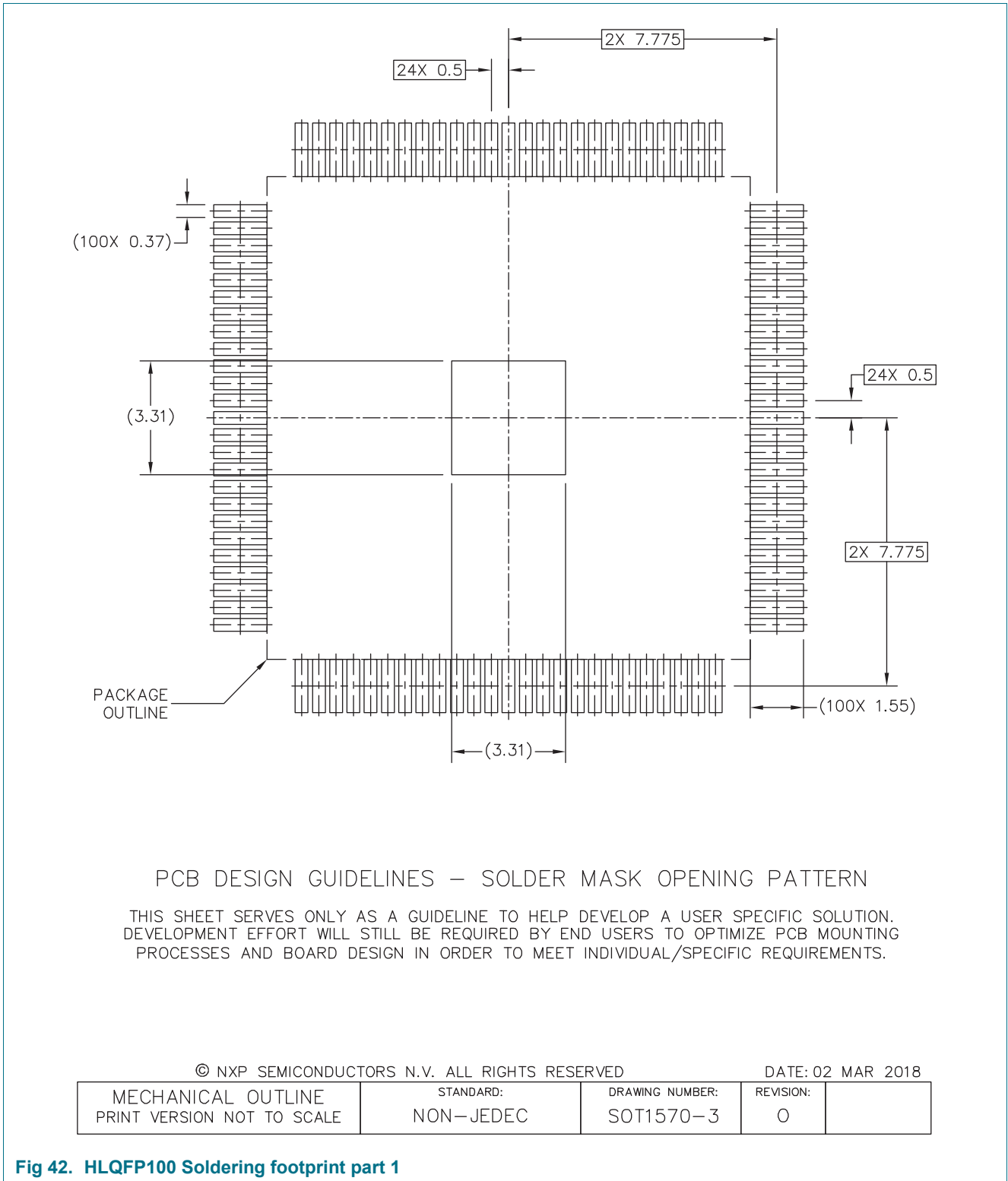
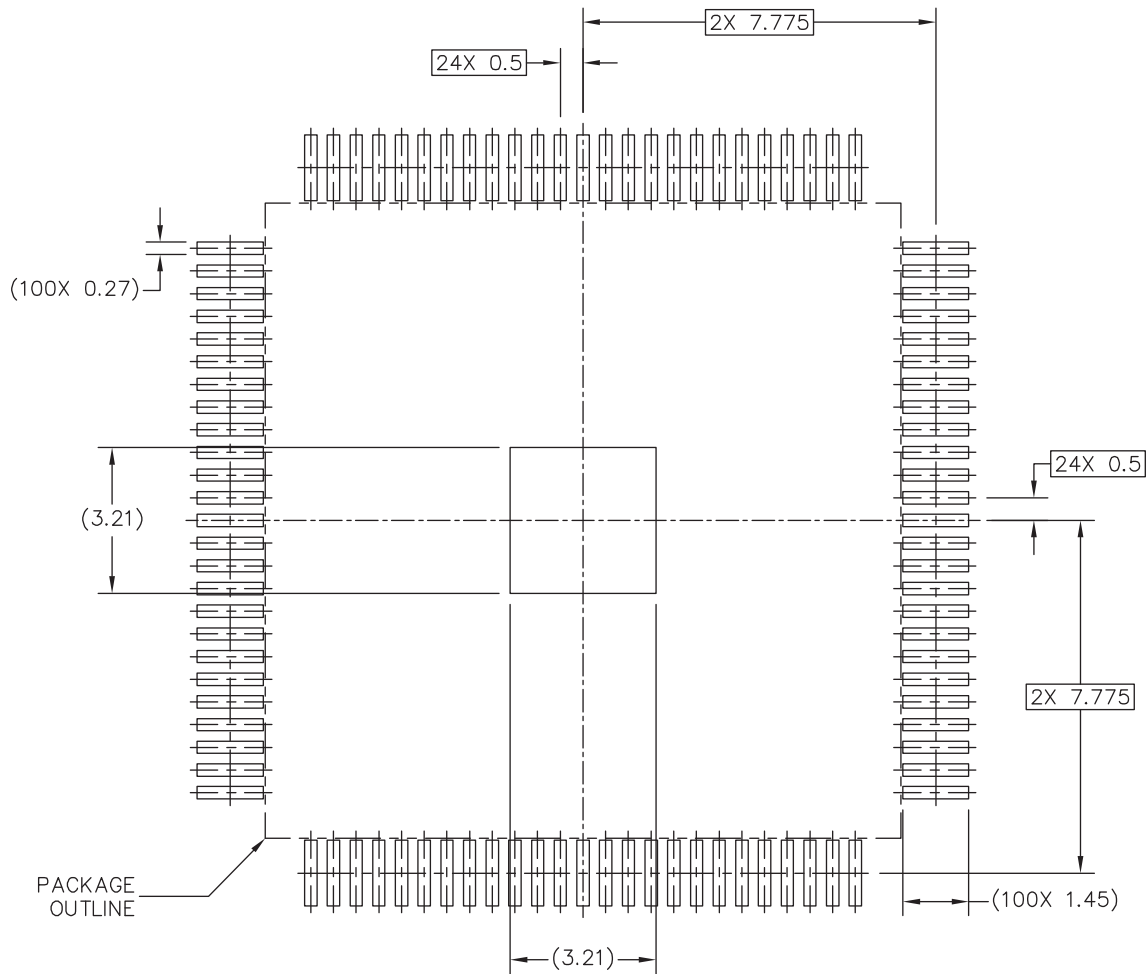

Fig 42. HLQFP100 Soldering footprint part 1



PCB DESIGN GUIDELINES – I/O PADS AND SOLDERABLE AREA

THIS SHEET SERVES ONLY AS A GUIDELINE TO HELP DEVELOP A USER SPECIFIC SOLUTION. DEVELOPMENT EFFORT WILL STILL BE REQUIRED BY END USERS TO OPTIMIZE PCB MOUNTING PROCESSES AND BOARD DESIGN IN ORDER TO MEET INDIVIDUAL/SPECIFIC REQUIREMENTS.

© NXP SEMICONDUCTORS N.V. ALL RIGHTS RESERVED

DATE: 02 MAR 2018

MECHANICAL OUTLINE PRINT VERSION NOT TO SCALE	STANDARD: NON-JEDEC	DRAWING NUMBER: SOT1570-3	REVISION: 0	
--	------------------------	------------------------------	----------------	--

Fig 43. HLQFP100 Soldering footprint part 2

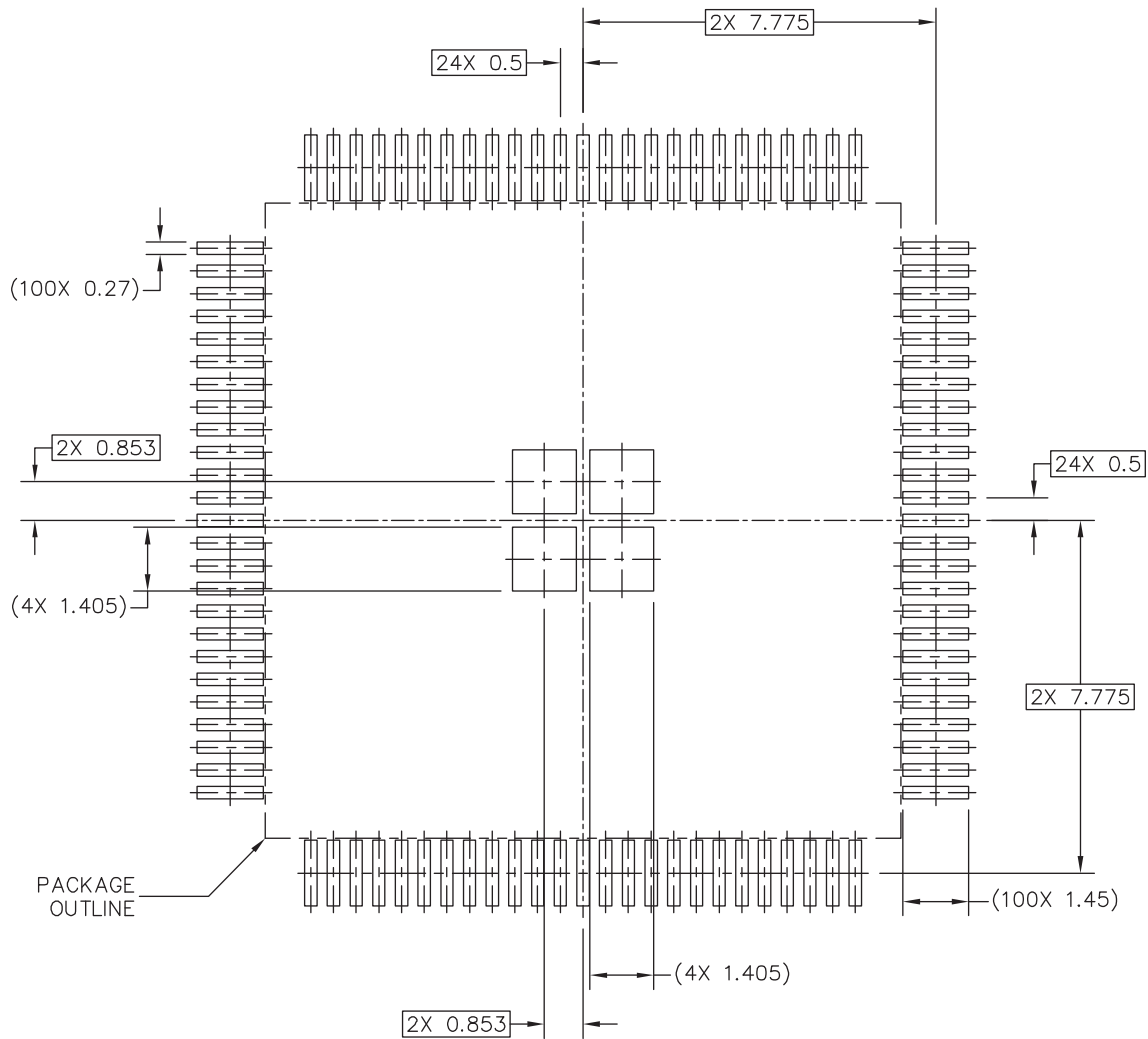

RECOMMENDED STENCIL THICKNESS 0.125 OR 0.15

PCB DESIGN GUIDELINES – SOLDER PASTE STENCIL

THIS SHEET SERVES ONLY AS A GUIDELINE TO HELP DEVELOP A USER SPECIFIC SOLUTION. DEVELOPMENT EFFORT WILL STILL BE REQUIRED BY END USERS TO OPTIMIZE PCB MOUNTING PROCESSES AND BOARD DESIGN IN ORDER TO MEET INDIVIDUAL/SPECIFIC REQUIREMENTS.

© NXP SEMICONDUCTORS N.V. ALL RIGHTS RESERVED

DATE: 02 MAR 2018

MECHANICAL OUTLINE PRINT VERSION NOT TO SCALE	STANDARD: NON-JEDEC	DRAWING NUMBER: SOT1570-3	REVISION: 0	
--	------------------------	------------------------------	----------------	--

Fig 44. HLQFP100 Soldering footprint part 3

NOTES:

1. DIMENSIONS ARE IN MILLIMETERS.

2. DIMENSIONING AND TOLERANCING PER ASME Y14.5M-1994.

3. PIN 1 FEATURE SHAPE, SIZE AND LOCATION MAY VARY.

4. DATUMS A, B AND D TO BE DETERMINED AT DATUM PLANE H.

5. DIMENSION TO BE DETERMINED AT SEATING PLANE C.

6. THIS DIMENSION DOES NOT INCLUDE DAMBAR PROTRUSION. ALLOWABLE DAMBAR PROTRUSION SHALL NOT CAUSE THE LEAD WIDTH TO EXCEED THE UPPER LIMIT BY MORE THAN 0.08MM AT MAXIMUM MATERIAL CONDITION. DAMBAR CANNOT BE LOCATED ON THE LOWER RADIUS OR THE FOOT. MINIMUM SPACE BETWEEN PROTRUSION AND ADJACENT LEAD SHALL NOT BE LESS THAN 0.07MM.

7. THIS DIMENSION DOES NOT INCLUDE MOLD PROTRUSION. ALLOWABLE PROTRUSION IS 0.25MM PER SIDE. THIS DIMENSION IS MAXIMUM PLASTIC BODY SIZE DIMENSION INCLUDING MOLD MISMATCH.

8. EXACT SHAPE OF EACH CORNER IS OPTIONAL.

9. HATCHED AREA TO BE KEEP OUT ZONE FOR PCB ROUTING.

© NXP SEMICONDUCTORS N.V. ALL RIGHTS RESERVED

DATE: 02 MAR 2018

MECHANICAL OUTLINE PRINT VERSION NOT TO SCALE	STANDARD: NON-JEDEC	DRAWING NUMBER: SOT1570-3	REVISION: 0	
--	------------------------	------------------------------	----------------	--

Fig 45. HLQFP100 Soldering footprint 4

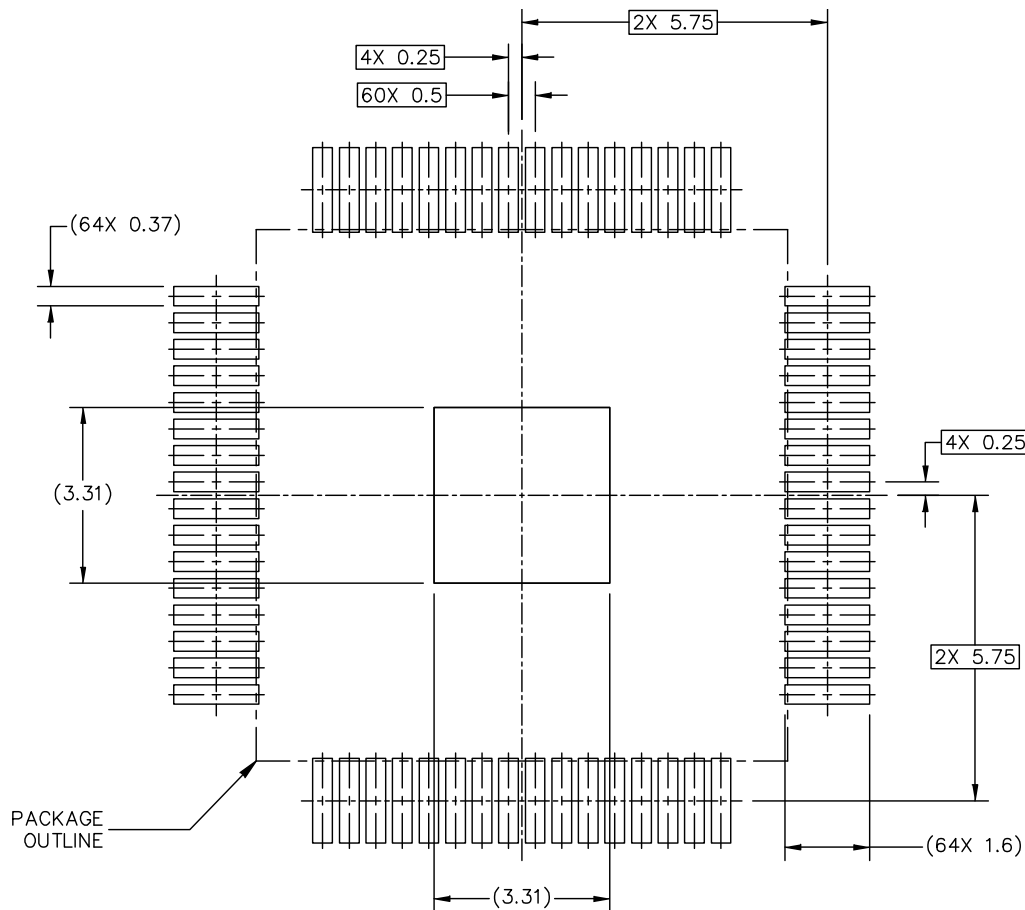

PCB DESIGN GUIDELINES – SOLDER MASK OPENING PATTERN

THIS SHEET SERVES ONLY AS A GUIDELINE TO HELP DEVELOP A USER SPECIFIC SOLUTION. DEVELOPMENT EFFORT WILL STILL BE REQUIRED BY END USERS TO OPTIMIZE PCB MOUNTING PROCESSES AND BOARD DESIGN IN ORDER TO MEET INDIVIDUAL/SPECIFIC REQUIREMENTS.

© NXP B.V. ALL RIGHTS RESERVED

DATE: 18 DEC 2018

MECHANICAL OUTLINE PRINT VERSION NOT TO SCALE	STANDARD: NON JEDEC	DRAWING NUMBER: 98ASA01376D	REVISION: 0	
--	------------------------	--------------------------------	----------------	--

Fig 46. HTQFP64 Soldering footprint part 1

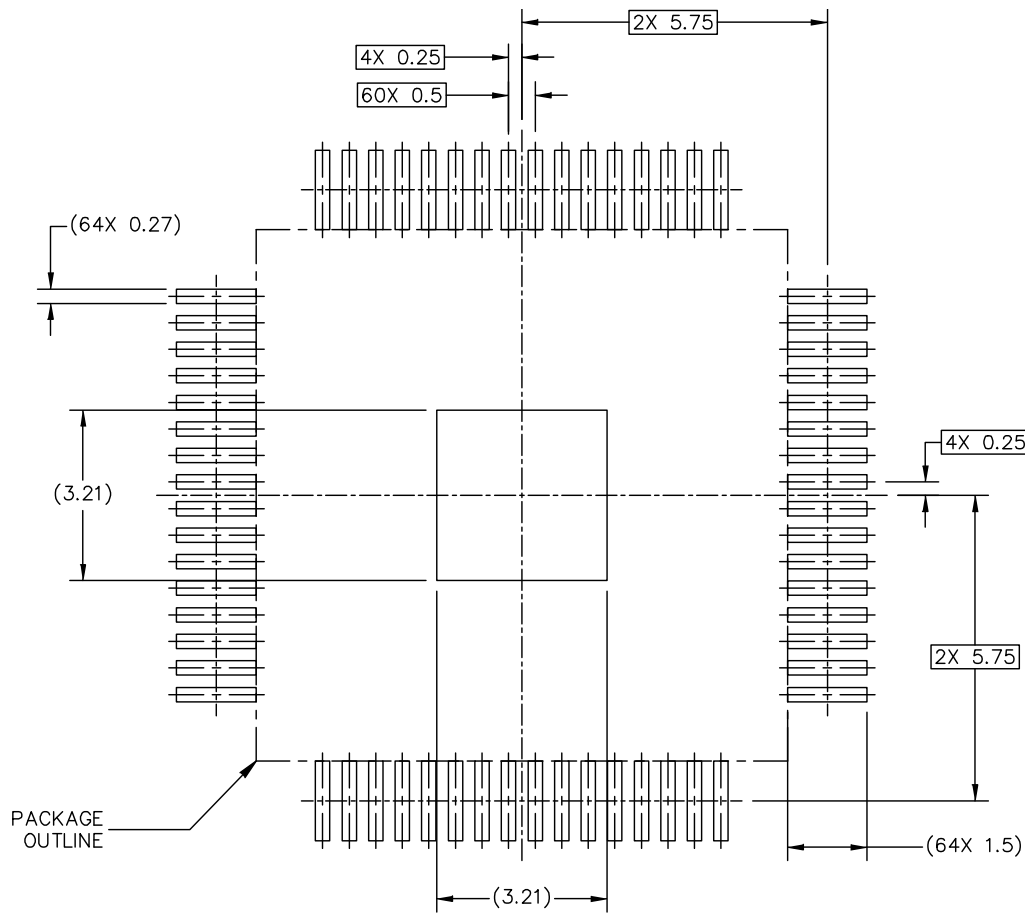

PCB DESIGN GUIDELINES – I/O PADS AND SOLDERABLE AREA

THIS SHEET SERVES ONLY AS A GUIDELINE TO HELP DEVELOP A USER SPECIFIC SOLUTION. DEVELOPMENT EFFORT WILL STILL BE REQUIRED BY END USERS TO OPTIMIZE PCB MOUNTING PROCESSES AND BOARD DESIGN IN ORDER TO MEET INDIVIDUAL/SPECIFIC REQUIREMENTS.

© NXP B.V. ALL RIGHTS RESERVED

DATE: 18 DEC 2018

MECHANICAL OUTLINE PRINT VERSION NOT TO SCALE	STANDARD: NON JEDEC	DRAWING NUMBER: 98ASA01376D	REVISION: 0	
--	------------------------	--------------------------------	----------------	--

Fig 47. HTQFP64 Soldering footprint part 2

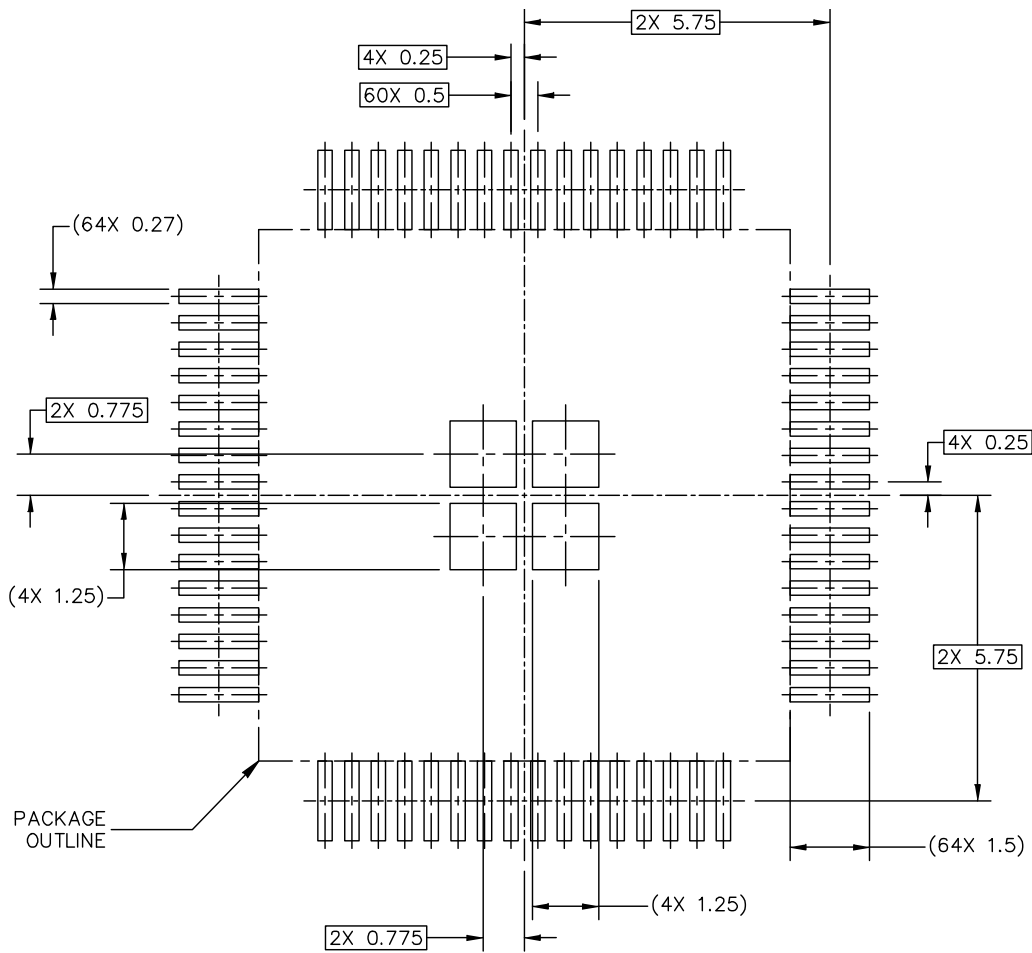

RECOMMENDED STENCIL THICKNESS 0.125 OR 0.15

PCB DESIGN GUIDELINES – SOLDER PASTE STENCIL

THIS SHEET SERVES ONLY AS A GUIDELINE TO HELP DEVELOP A USER SPECIFIC SOLUTION. DEVELOPMENT EFFORT WILL STILL BE REQUIRED BY END USERS TO OPTIMIZE PCB MOUNTING PROCESSES AND BOARD DESIGN IN ORDER TO MEET INDIVIDUAL/SPECIFIC REQUIREMENTS.

© NXP B.V. ALL RIGHTS RESERVED

DATE: 18 DEC 2018

MECHANICAL OUTLINE PRINT VERSION NOT TO SCALE	STANDARD: NON JEDEC	DRAWING NUMBER: 98ASA01376D	REVISION: 0	
--	------------------------	--------------------------------	----------------	--

Fig 48. HTQFP64 Soldering footprint part 3

NOTES:

1. DIMENSIONS ARE IN MILLIMETERS.

2. DIMENSIONING AND TOLERANCING PER ASME Y14.5M-1994.

3. PIN 1 FEATURE SHAPE, SIZE AND LOCATION MAY VARY.

4. DATUMS A, B AND D TO BE DETERMINED AT DATUM PLANE H.

5. DIMENSION TO BE DETERMINED AT SEATING PLANE C.

6. THIS DIMENSION DOES NOT INCLUDE DAMBAR PROTRUSION. ALLOWABLE DAMBAR PROTRUSION SHALL NOT CAUSE THE LEAD WIDTH TO EXCEED THE UPPER LIMIT BY MORE THAN 0.08MM AT MAXIMUM MATERIAL CONDITION. DAMBAR CANNOT BE LOCATED ON THE LOWER RADIUS OR THE FOOT. MINIMUM SPACE BETWEEN PROTRUSION AND ADJACENT LEAD SHALL NOT BE LESS THAN 0.07MM.

7. THIS DIMENSION DOES NOT INCLUDE MOLD PROTRUSION. ALLOWABLE PROTRUSION IS 0.25MM PER SIDE. THIS DIMENSION IS MAXIMUM PLASTIC BODY SIZE DIMENSION INCLUDING MOLD MISMATCH.

8. EXACT SHAPE OF EACH CORNER IS OPTIONAL.

9. HATCHED AREA TO BE KEEP OUT ZONE FOR PCB ROUTING.

© NXP B.V. ALL RIGHTS RESERVED

DATE: 18 DEC 2018

MECHANICAL OUTLINE PRINT VERSION NOT TO SCALE	STANDARD: NON JEDEC	DRAWING NUMBER: 98ASA01376D	REVISION: 0	
--	------------------------	--------------------------------	----------------	--

Fig 49. HTQFP64 Soldering footprint 4

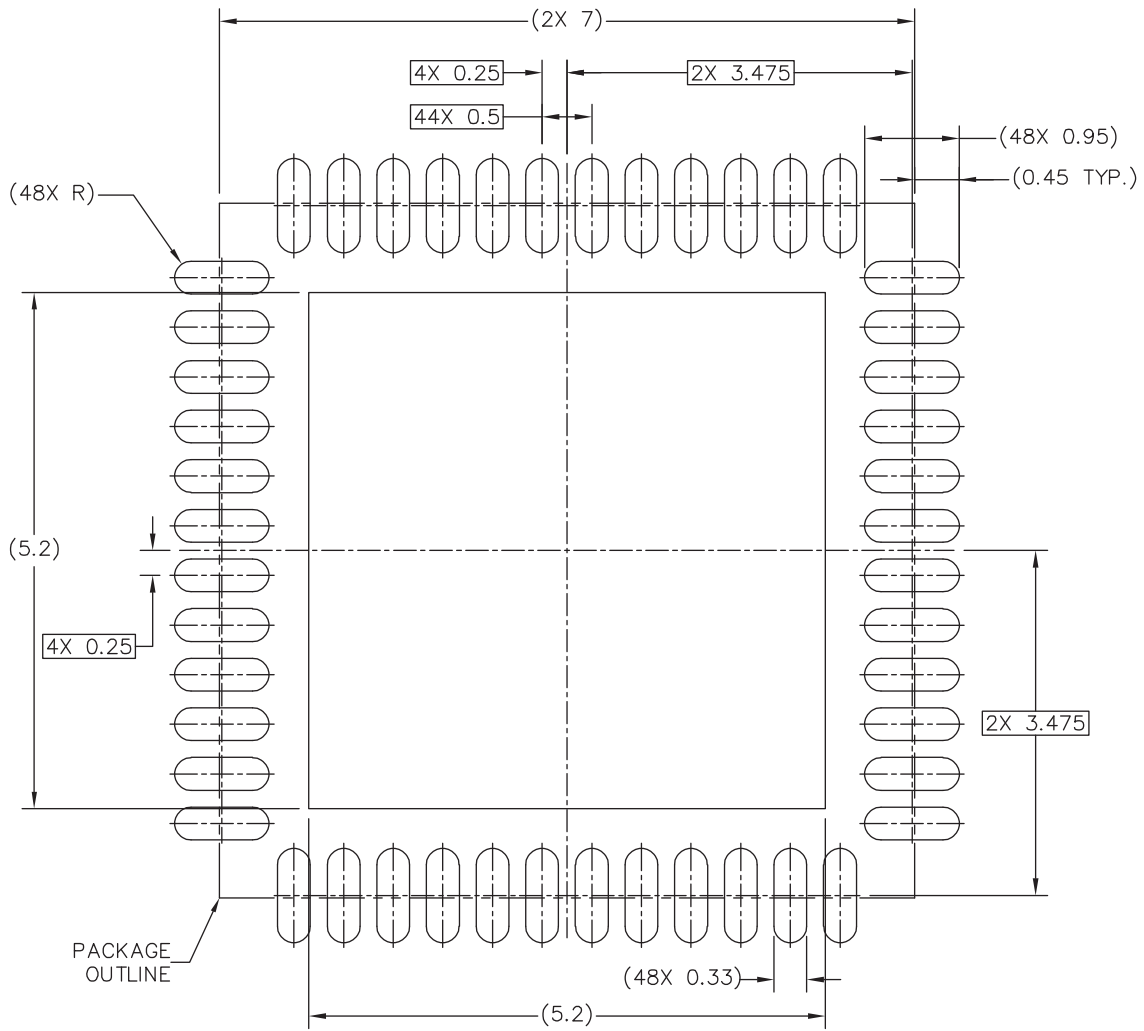

PCB DESIGN GUIDELINES – SOLDER MASK OPENING PATTERN

THIS SHEET SERVES ONLY AS A GUIDELINE TO HELP DEVELOP A USER SPECIFIC SOLUTION. DEVELOPMENT EFFORT WILL STILL BE REQUIRED BY END USERS TO OPTIMIZE PCB MOUNTING PROCESSES AND BOARD DESIGN IN ORDER TO MEET INDIVIDUAL/SPECIFIC REQUIREMENTS.

© NXP SEMICONDUCTORS N.V. ALL RIGHTS RESERVED

DATE: 13 DEC 2017

MECHANICAL OUTLINE PRINT VERSION NOT TO SCALE	STANDARD: NON JEDEC	DRAWING NUMBER: SOT619-1	REVISION: 0	
--	------------------------	-----------------------------	----------------	--

Fig 50. Reflow soldering of the HVQFN48 package (7 x7) 1 of 3

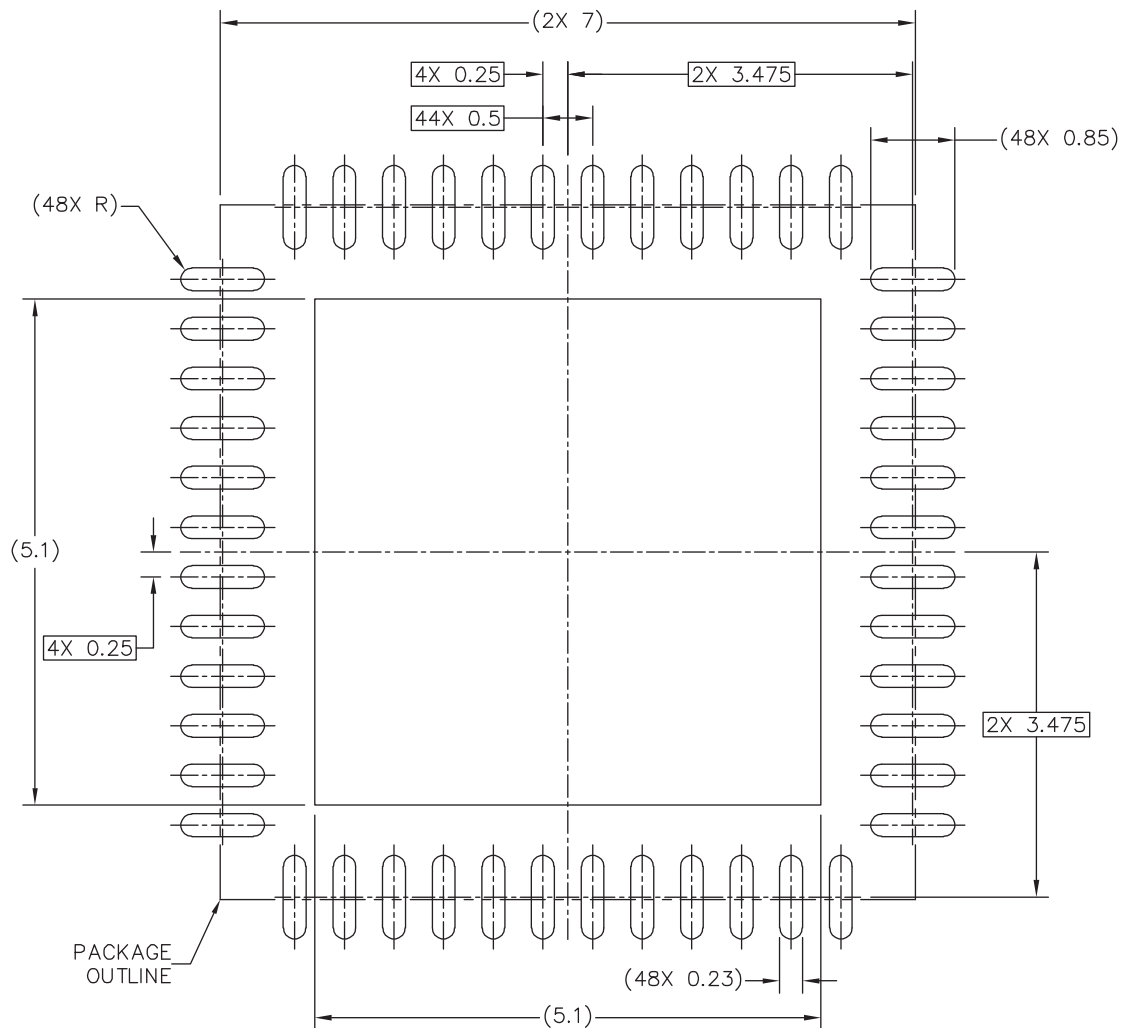

PCB DESIGN GUIDELINES – I/O PADS AND SOLDERABLE AREA

THIS SHEET SERVES ONLY AS A GUIDELINE TO HELP DEVELOP A USER SPECIFIC SOLUTION. DEVELOPMENT EFFORT WILL STILL BE REQUIRED BY END USERS TO OPTIMIZE PCB MOUNTING PROCESSES AND BOARD DESIGN IN ORDER TO MEET INDIVIDUAL/SPECIFIC REQUIREMENTS.

© NXP SEMICONDUCTORS N.V. ALL RIGHTS RESERVED

DATE: 13 DEC 2017

MECHANICAL OUTLINE PRINT VERSION NOT TO SCALE	STANDARD: NON JEDEC	DRAWING NUMBER: SOT619-1	REVISION: 0	
--	------------------------	-----------------------------	----------------	--

Fig 51. Reflow soldering of the HVQFN48 package (7 x7) 2 of 3

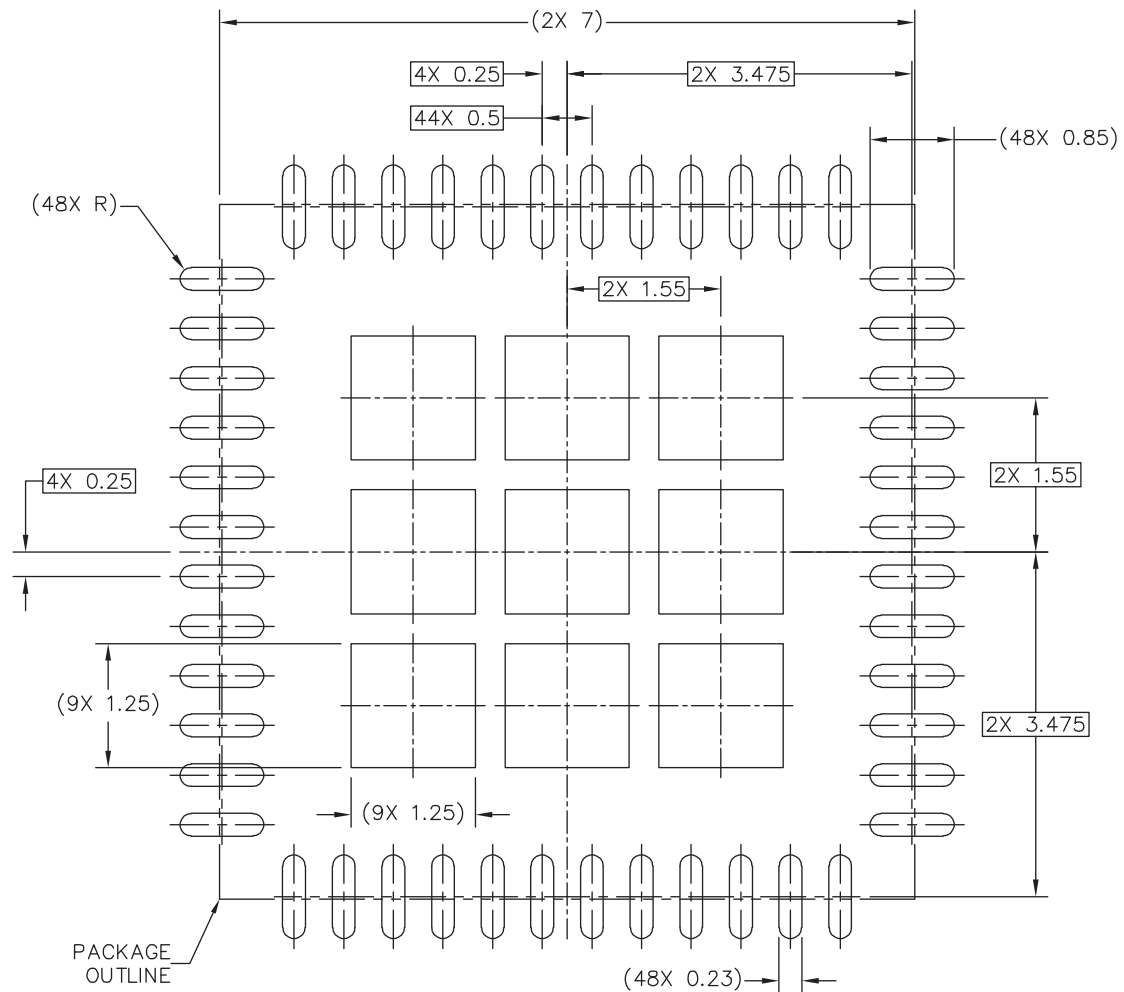

RECOMMENDED STENCIL THICKNESS 0.125

PCB DESIGN GUIDELINES – SOLDER PASTE STENCIL

THIS SHEET SERVES ONLY AS A GUIDELINE TO HELP DEVELOP A USER SPECIFIC SOLUTION. DEVELOPMENT EFFORT WILL STILL BE REQUIRED BY END USERS TO OPTIMIZE PCB MOUNTING PROCESSES AND BOARD DESIGN IN ORDER TO MEET INDIVIDUAL/SPECIFIC REQUIREMENTS.

© NXP SEMICONDUCTORS N.V. ALL RIGHTS RESERVED

DATE: 13 DEC 2017

MECHANICAL OUTLINE PRINT VERSION NOT TO SCALE	STANDARD: NON JEDEC	DRAWING NUMBER: SOT619-1	REVISION: 0	
--	------------------------	-----------------------------	----------------	--

Fig 52. Reflow soldering of the HVQFN48 package (7 x7) 3 of 3

16. Abbreviations

Table 55. Abbreviations

Acronym	Description
AHB	Advanced High-performance Bus
APB	Advanced Peripheral Bus
API	Application Programming Interface
DMA	Direct Memory Access
FRO oscillator	Internal Free-Running Oscillator, tuned to the factory specified frequency
GPIO	General Purpose Input/Output
FRO	Free Running Oscillator
LSB	Least Significant Bit
MCU	MicroController Unit
PDM	Pulse Density Modulation
PLL	Phase-Locked Loop
SPI	Serial Peripheral Interface
TCP/IP	Transmission Control Protocol/Internet Protocol
TTL	Transistor-Transistor Logic
USART	Universal Asynchronous Receiver/Transmitter

17. Revision history

Table 56. Revision History

Revision	Release date	
1.0	2022-04-04	Initial release

18. Contents

1.	General description	1	7.18	Pin interrupt/pattern engine	67
2.	Features and benefits	1	7.18.1	Features	67
3.	Ordering information	6	7.19	Communication peripherals	67
3.1	Ordering options	6	7.19.1	Full-speed USB Host/Device Interface (USB0)	67
4.	Marking	7	7.19.1.1	USB0 device controller	67
5.	Block diagram	9	7.19.1.2	USB0 host controller	68
6.	Pinning information	10	7.19.2	Flexcomm Interface serial communication	68
6.1	Pin description	10	7.19.2.1	Features	68
6.1.1	Power Supply for pins	52	7.19.2.2	SPI serial I/O (SPI0) controller	68
6.1.2	Termination of unused pins	53	7.19.2.3	I ² C-bus interface	69
6.1.3	Using Internal DC-DC converter	54	7.19.2.4	USART	69
7.	Functional description	55	7.19.2.5	I ² S-bus interface	70
7.1	Architectural overview	55	7.19.3	High-Speed SPI serial I/O (SPI0 controller)	71
7.2	Arm Cortex-M33 processor	55	7.19.3.1	Features	71
7.3	Arm Cortex-M33 integrated Floating Point Unit (FPU)	55	7.19.4	I3C interface	71
7.4	Memory Protection Unit (MPU)	55	7.19.4.1	Features	72
7.5	Nested Vectored Interrupt Controller (NVIC) for Cortex-M33	56	7.20	CAN Flexible Data (CAN FD) interface	72
7.5.1	Features	56	7.20.1	Features	72
7.5.2	Interrupt sources	56	7.21	Standard counter/timers (CT32B0 to 4)	72
7.6	System Tick timer (SysTick)	56	7.21.1	Features	72
7.7	PowerQuad Hardware Accelerator	56	7.22	SCTimer/PWM subsystem	73
7.8	On-chip static RAM	56	7.22.1	Features	73
7.8.1	RAM partitions	57	7.23	Windowed Watchdog Timer (WWDT)	74
7.9	On-chip flash	57	7.23.1	Features	74
7.10	On-chip ROM	57	7.24	Code Watchdog Timer (CDOG)	75
7.10.1	FlexSPI Flash Interface	58	7.24.1	Features	75
7.10.1.1	Features	58	7.25	RTC timer	75
7.11	Protected Flash Region (PFR)	59	7.25.1	Features	75
7.12	OTP eFuse	59	7.26	Multi-Rate Timer (MRT)	76
7.13	Memory mapping	59	7.26.1	Features	76
7.14	AHB multilayer matrix	59	7.27	OS Timer	76
7.15	System control	59	7.27.1	Features	76
7.15.1	Clock sources	59	7.28	Micro-tick timer (UTICK)	76
7.15.2	PLL (PLL0 and PLL1)	60	7.28.1	Features	76
7.15.3	Clock generation	60	7.29	Motor Control Subsystem	76
7.15.4	Brownout detection	64	7.29.1	FlexPWM	77
7.16	Power control	64	7.29.1.1	Features	77
7.16.1	DC-DC Buck Converter and Low Drop-Out (LDO)	65	7.29.2	QEI	77
7.16.2	Sleep mode	65	7.29.3	OpAmps	77
7.16.3	Deep-sleep mode	65	7.29.4	Comparators	77
7.16.4	Power-down mode	65	7.29.4.1	Features	77
7.16.5	Deep Power-down mode	66	7.30	Digital peripherals	77
7.17	General Purpose I/O (GPIO)	66	7.30.1	DMA controller	77
7.17.1	Features	66	7.30.1.1	Features	78
			7.30.2	DMIC subsystem	78
			7.30.2.1	Features	78
			7.30.3	CRC engine	78
			7.30.3.1	Features	78

continued >>

7.31	Analog peripherals	79	16.	Abbreviations	155
7.31.1	16-bit Analog-to-Digital Converters (ADC)	79	17.	Revision history	156
7.31.1.1	Features	79	18.	Contents	157
7.31.2	12-DAC Digital-to-Analog Converter (DAC)	79			
7.31.3	Temperature sensors	79			
7.32	Universally Unique Identifier (UUID)	79			
7.33	Code Watchdog Timer (CDOG)	80			
7.34	Code Read Protection	80			
7.35	Emulation and debugging	80			
8.	Limiting values	81			
9.	Thermal characteristics	83			
10.	Static characteristics	84			
10.1	General operating conditions	84			
10.2	CoreMark data	85			
10.3	Power consumption	86			
10.3.1	Peripheral Power Consumption	92			
10.4	Pin characteristics	96			
11.	Dynamic characteristics	99			
11.1	Flash memory	99			
11.2	I/O pins	99			
11.3	Wake-up process	100			
11.4	FRO (12 MHz/96 MHz) (extended temperature)	100			
11.5	FRO (12 MHz/96 MHz)	101			
11.6	FRO (1 MHz)	101			
11.7	FRO (32 kHz)	101			
11.8	RTC oscillator	101			
11.9	I ² C-bus	101			
11.11	I ² S-bus interface	106			
11.12	SPI interface (Flexcomm Interfaces 0 - 7)	109			
11.13	High-Speed SPI interface (Flexcomm Interface 8)	112			
11.14	USART interface	115			
11.15	FlexSPI flash interface	116			
11.16	DMIC subsystem	119			
11.17	SCTimer/PWM output timing	119			
11.18	FlexPWM output timing	119			
12.	Analog characteristics	120			
12.1	BOD	120			
12.2	16-bit ADC characteristics	121			
12.2.1	ADC input resistance	124			
12.3	Temperature sensors	124			
12.4	Comparators	125			
12.5	Voltage reference electrical specifications	129			
12.6	DAC specifications	130			
12.7	Op-Amp specifications	131			
13.	Application information	134			
13.1	I/O power consumption	134			
13.2	Crystal oscillator	134			
13.2.1	Crystal Printed Circuit Board (PCB) design guidelines	135			
13.3	RTC oscillator	135			
13.3.1	RTC Printed Circuit Board (PCB) design guidelines	136			
14.	Package outline	139			
15.	Soldering	144			

Legal information

Data sheet status

Document status ^{[1][2]}	Product status ^[3]	Definition
Objective [short] data sheet	Development	This document contains data from the objective specification for product development.
Preliminary [short] data sheet	Qualification	This document contains data from the preliminary specification.
Product [short] data sheet	Production	This document contains the product specification.

[1] Please consult the most recently issued document before initiating or completing a design.

[2] The term 'short data sheet' is explained in section "Definitions".

[3] The product status of device(s) described in this document may have changed since this document was published and may differ in case of multiple devices. The latest product status information is available on the Internet at URL <http://www.nxp.com>.

Definitions

Draft — A draft status on a document indicates that the content is still under internal review and subject to formal approval, which may result in modifications or additions. NXP Semiconductors does not give any representations or warranties as to the accuracy or completeness of information included in a draft version of a document and shall have no liability for the consequences of use of such information.

Short data sheet — A short data sheet is an extract from a full data sheet with the same product type number(s) and title. A short data sheet is intended for quick reference only and should not be relied upon to contain detailed and full information. For detailed and full information see the relevant full data sheet, which is available on request via the local NXP Semiconductors sales office. In case of any inconsistency or conflict with the short data sheet, the full data sheet shall prevail.

Product specification — The information and data provided in a Product data sheet shall define the specification of the product as agreed between NXP Semiconductors and its customer, unless NXP Semiconductors and customer have explicitly agreed otherwise in writing. In no event however, shall an agreement be valid in which the NXP Semiconductors product is deemed to offer functions and qualities beyond those described in the Product data sheet.

Disclaimers

Limited warranty and liability — Information in this document is believed to be accurate and reliable. However, NXP Semiconductors does not give any representations or warranties, expressed or implied, as to the accuracy or completeness of such information and shall have no liability for the consequences of use of such information. NXP Semiconductors takes no responsibility for the content in this document if provided by an information source outside of NXP Semiconductors.

In no event shall NXP Semiconductors be liable for any indirect, incidental, punitive, special or consequential damages (including - without limitation - lost profits, lost savings, business interruption, costs related to the removal or replacement of any products or rework charges) whether or not such damages are based on tort (including negligence), warranty, breach of contract or any other legal theory.

Notwithstanding any damages that customer might incur for any reason whatsoever, NXP Semiconductors' aggregate and cumulative liability towards customer for the products described herein shall be limited in accordance with the Terms and conditions of commercial sale of NXP Semiconductors.

Right to make changes — NXP Semiconductors reserves the right to make changes to information published in this document, including without limitation specifications and product descriptions, at any time and without notice. This document supersedes and replaces all information supplied prior to the publication hereof.

Suitability for use — NXP Semiconductors products are not designed, authorized or warranted to be suitable for use in life support, life-critical or safety-critical systems or equipment, nor in applications where failure or malfunction of an NXP Semiconductors product can reasonably be expected to result in personal injury, death or severe property or environmental damage. NXP Semiconductors and its suppliers accept no liability for inclusion and/or use of NXP Semiconductors products in such equipment or applications and therefore such inclusion and/or use is at the customer's own risk.

Applications — Applications that are described herein for any of these products are for illustrative purposes only. NXP Semiconductors makes no representation or warranty that such applications will be suitable for the specified use without further testing or modification.

Customers are responsible for the design and operation of their applications and products using NXP Semiconductors products, and NXP Semiconductors accepts no liability for any assistance with applications or customer product design. It is customer's sole responsibility to determine whether the NXP Semiconductors product is suitable and fit for the customer's applications and products planned, as well as for the planned application and use of customer's third party customer(s). Customers should provide appropriate design and operating safeguards to minimize the risks associated with their applications and products.

NXP Semiconductors does not accept any liability related to any default, damage, costs or problem which is based on any weakness or default in the customer's applications or products, or the application or use by customer's third party customer(s). Customer is responsible for doing all necessary testing for the customer's applications and products using NXP Semiconductors products in order to avoid a default of the applications and the products or of the application or use by customer's third party customer(s). NXP does not accept any liability in this respect.

Limiting values — Stress above one or more limiting values (as defined in the Absolute Maximum Ratings System of IEC 60134) will cause permanent damage to the device. Limiting values are stress ratings only and (proper) operation of the device at these or any other conditions above those given in the Recommended operating conditions section (if present) or the Characteristics sections of this document is not warranted. Constant or repeated exposure to limiting values will permanently and irreversibly affect the quality and reliability of the device.

Terms and conditions of commercial sale — NXP Semiconductors products are sold subject to the general terms and conditions of commercial sale, as published at <http://www.nxp.com/profile/terms>, unless otherwise agreed in a valid written individual agreement. In case an individual agreement is concluded only the terms and conditions of the respective agreement shall apply. NXP Semiconductors hereby expressly objects to applying the customer's general terms and conditions with regard to the purchase of NXP Semiconductors products by customer.

No offer to sell or license — Nothing in this document may be interpreted or construed as an offer to sell products that is open for acceptance or the grant, conveyance or implication of any license under any copyrights, patents or other industrial or intellectual property rights.

Export control — This document as well as the item(s) described herein may be subject to export control regulations. Export might require a prior authorization from competent authorities.

Suitability for use in non-automotive qualified products — Unless this data sheet expressly states that this specific NXP Semiconductors product is automotive qualified, the product is not suitable for automotive use. It is neither qualified nor tested in accordance with automotive testing or application requirements. NXP Semiconductors accepts no liability for inclusion and/or use of non-automotive qualified products in automotive equipment or applications.

In the event that customer uses the product for design-in and use in automotive applications to automotive specifications and standards, customer (a) shall use the product without NXP Semiconductors' warranty of the product for such automotive applications, use and specifications, and (b) whenever customer uses the product for automotive applications beyond NXP Semiconductors' specifications such use shall be solely at customer's own risk, and (c) customer fully indemnifies NXP Semiconductors for any liability, damages or failed product claims resulting from customer design and use of the product for automotive applications beyond NXP Semiconductors' standard warranty and NXP Semiconductors' product specifications.

Security — Customer understands that all NXP products may be subject to unidentified vulnerabilities or may support established security standards or specifications with known limitations. Customer is responsible for the design and operation of its applications and products throughout their lifecycles to reduce the effect of these vulnerabilities on customer's applications and products. Customer's responsibility also extends to other open and/or proprietary technologies supported by NXP products for use in customer's applications. NXP accepts no liability for any vulnerability. Customer should regularly check security updates from NXP and follow up appropriately.

Customer shall select products with security features that best meet rules, regulations, and standards of the intended application and make the ultimate design decisions regarding its products and is solely responsible for compliance with all legal, regulatory, and security related requirements concerning its products, regardless of any information or support that may be provided by NXP.

NXP has a Product Security Incident Response Team (PSIRT) (reachable at PSIRT@nxp.com) that manages the investigation, reporting, and solution release to security vulnerabilities of NXP products.

Trademarks

Notice: All referenced brands, product names, service names, and trademarks are the property of their respective owners.

NXP — wordmark and logo are trademarks of NXP B.V.

AMBA, Arm, Arm7, Arm7TDMI, Arm9, Arm11, Artisan, big.LITTLE, Cordio, CoreLink, CoreSight, Cortex, DesignStart, DynamIQ, Jazelle, Keil, Mail, Mbed, Mbed Enabled, NEON, POP, RealView, SecurCore, Socrates, Thumb, TrustZone, ULINK, ULINK2, ULINK-ME, ULINK-PLUS, ULINKpro, μ Vision, Versatile — are trademarks or registered trademarks of Arm Limited (or its subsidiaries) in the US and/or elsewhere. The related technology may be protected by any or all of patents, copyrights, designs and trade secrets. All rights reserved.

I2C-bus — logo is a trademark of NXP B.V.