

LS1020A

QorIQ LS1020A Data Sheet

Features

- ARM® Cortex®-A7 MPCore compliant with ARMv7-A™ architecture
- LS1020A contains a dual-core Cortex-A7. Each core includes:
 - 32 KB L1 Instruction Cache (ECC protection)
 - 32 KB L1 Data Cache (ECC protection)
 - NEON Co-processor
 - Floating Point (FPU)
 - QorIQ Trust Architecture and ARM TrustZone®
- Snoop Control Unit (SCU)
- 512 KB unified I/D L2 Cache (ECC protection)
- Hierarchical interconnect fabric
 - The platform has a single 128-bit AMBA 4 AXI Coherency Extensions (ACE) master port, which connects to CCI-400 Interconnect.
- One 8/16/32-bit DDR3L/DDR4 SDRAM memory controllers
 - ECC and interleaving support
- VeTSEC Ethernet complex
 - Up to 3x Gigabit Ethernet
 - MII, RMII, RGMII, and SGMII support
 - QoS, lossless flow control, and IEEE® 1588
- Up to 4 SerDes lanes for high-speed peripheral interfaces
 - Two PCI Express Gen2 controllers
 - One Serial ATA 3.0 (SATA 1.5, 3.0, 6.0 Gbps) controller
 - Two SGMII interfaces supporting 1000 Mbps
- Integrated audio block
 - Four synchronous audio interfaces (SAI)
 - I2S, AC97, and Codec/DSP interfaces
 - Sony/Philips Digital Interconnect Format (S/PDIF)
 - Asynchronous Sample Rate Converter (ASRC)
- Additional peripheral interfaces
 - One high-speed USB 3.0 controller with integrated PHY
 - One high-speed USB 2.0 controller with ULPI
 - Enhanced secure digital host controller (eSDHC/MMC/eMMC)
 - Three I2C controllers
 - FlexTimer/PWM
 - SPI interface
 - QuadSPI controller
 - Two DUARTs
 - Six LPUART interfaces
 - Integrated flash controller supporting NAND and NOR flash
 - TDM interface
 - Four GPIO controllers supporting up to 109 general purpose I/O signals
 - One 4-channel qDMA controller and one eDMA controller
 - Global interrupt controller (GIC)
 - Thermal monitor unit (TMU)
- QUICC Engine ULite block
 - 32-bit RISC controller for flexible support of the communications peripherals
 - Serial DMA channel for receive and transmit on all serial channels
 - Two universal communication controllers (TDM and HDLC) supporting 64 multichannels, each running at 64 Kbps
- 525 FC-PBGA package, 19 mm x 19 mm

NXP reserves the right to change the production detail specifications as may be required to permit improvements in the design of its products.



Table of Contents

1	Introduction.....	3	3.20	SPI interface.....	127	
2	Pin assignments.....	4	3.21	QuadSPI interface.....	133	
	2.1	LS1020A Ball Map and Pin List.....	4	3.22	Enhanced secure digital host controller (eSDHC).....	135
3	Electrical characteristics.....	48	3.23	JTAG controller.....	144	
	3.1	Overall DC electrical characteristics.....	48	3.24	I2C interface.....	147
	3.2	Power sequencing.....	54	3.25	GPIO interface.....	150
	3.3	Power-down requirements.....	58	3.26	GIC interface.....	152
	3.4	Power characteristics.....	58	3.27	High-speed serial interfaces (HSSI).....	154
	3.5	I/O DC power supply recommendation.....	60	4	Hardware design considerations.....	175
	3.6	Power-on ramp rate.....	63	4.1	Power supply design.....	175
	3.7	Input clocks.....	63	4.2	Decoupling recommendations.....	180
	3.8	RESET initialization.....	70	4.3	SerDes block power supply decoupling recommendations.....	181
	3.9	DDR3L and DDR4 SDRAM controller.....	71	4.4	Connection recommendations.....	181
	3.10	DUART interface.....	77	4.5	Thermal.....	186
	3.11	Ethernet interface, Ethernet management interface, IEEE Std 1588.....	79	4.6	Recommended thermal model.....	186
	3.12	QUICC engine specifications.....	96	4.7	Thermal management information.....	187
	3.13	USB 2.0 interface.....	102	5	Package information.....	189
	3.14	USB 3.0 interface.....	105	5.1	Mechanical dimensions of the FC-PBGA.....	189
	3.15	Integrated flash controller (IFC).....	109	6	Security fuse processor.....	191
	3.16	LPUART interface.....	118	7	Ordering information.....	191
	3.17	Flextimer interface.....	120	7.1	Part numbering nomenclature.....	191
	3.18	SAI/I2S interface.....	122	7.2	Orderable part numbers addressed by this document.....	192
	3.19	SPDIF interface.....	125	8	Revision history.....	193

1 Introduction

A member of the Layerscape (LS1) series, the LS102xA family is a cost-effective, power-efficient, and highly integrated system-on-chip (SoC) design that extends the reach of the NXP value-performance line of QorIQ communications processors. Featuring a pair of extremely power-efficient 32-bit ARM® Cortex®-A7 cores with ECC-protected L1 and L2 cache memories for high reliability, running up to 1 GHz, and providing pre-silicon CoreMark® performance of over 5,000, the LS102xA family delivers greater performance than any previous sub-4W communication processor.

This chip can be used for networking and wireless access points, industrial gateways, industrial automation, printing, imaging, and M2M for enterprise and consumer networking and router applications.

This figure shows the block diagram of the LS1020A chip.

QorIQ LS1020A Processor Block Diagram

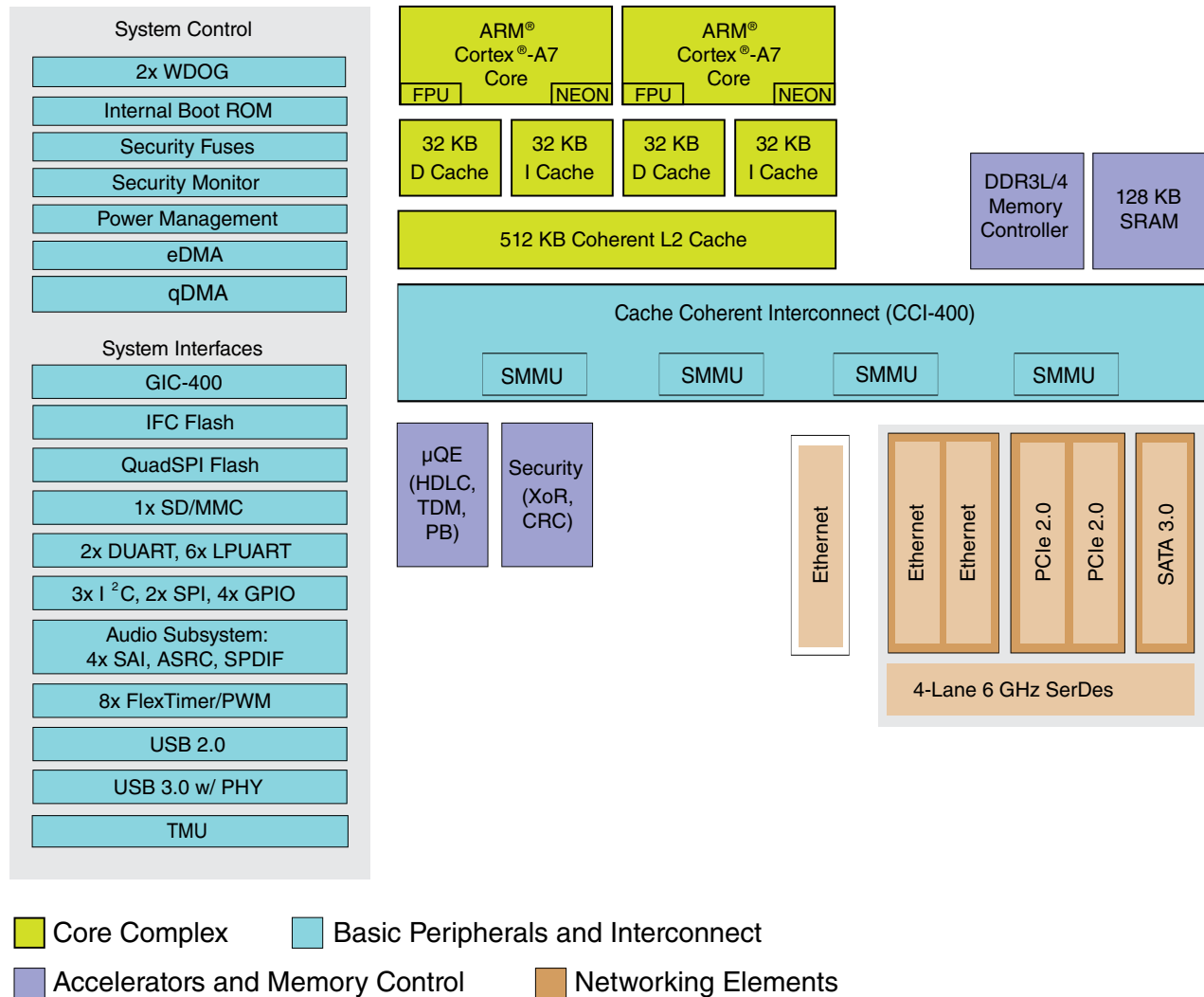

Figure 1. LS1020A block diagram

2 Pin assignments

2.1 LS1020A Ball Map and Pin List

2.1.1 525 ball layout diagrams

This figure shows the complete view of the LS1020A ball map diagram. [Figure 3](#), [Figure 4](#), [Figure 5](#), and [Figure 6](#) show quadrant views.

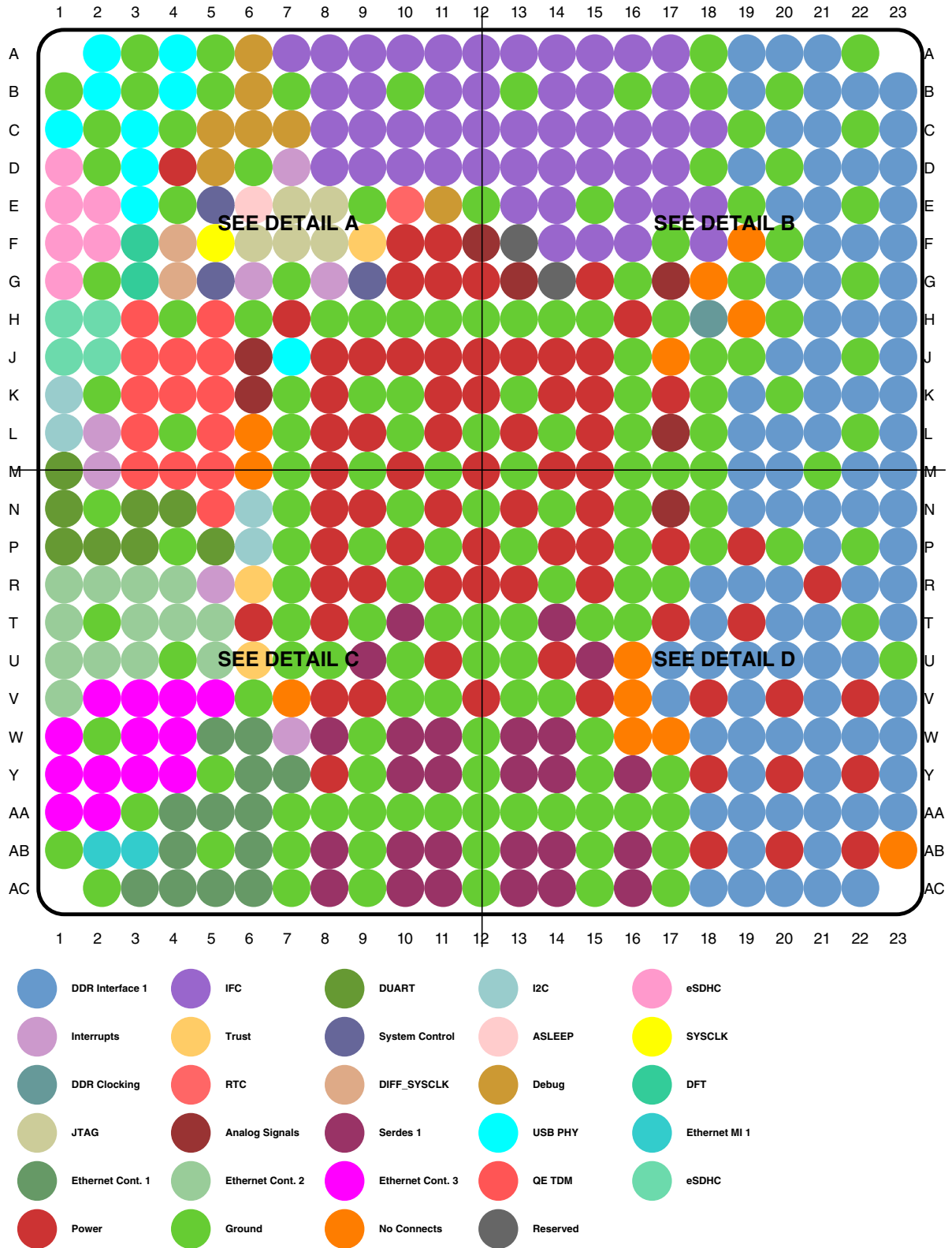

Figure 2. Complete BGA Map for the LS1020A

LS1020A Ball Map and Pin List



Figure 3. Detail A



Figure 4. Detail B

LS1020A Ball Map and Pin List

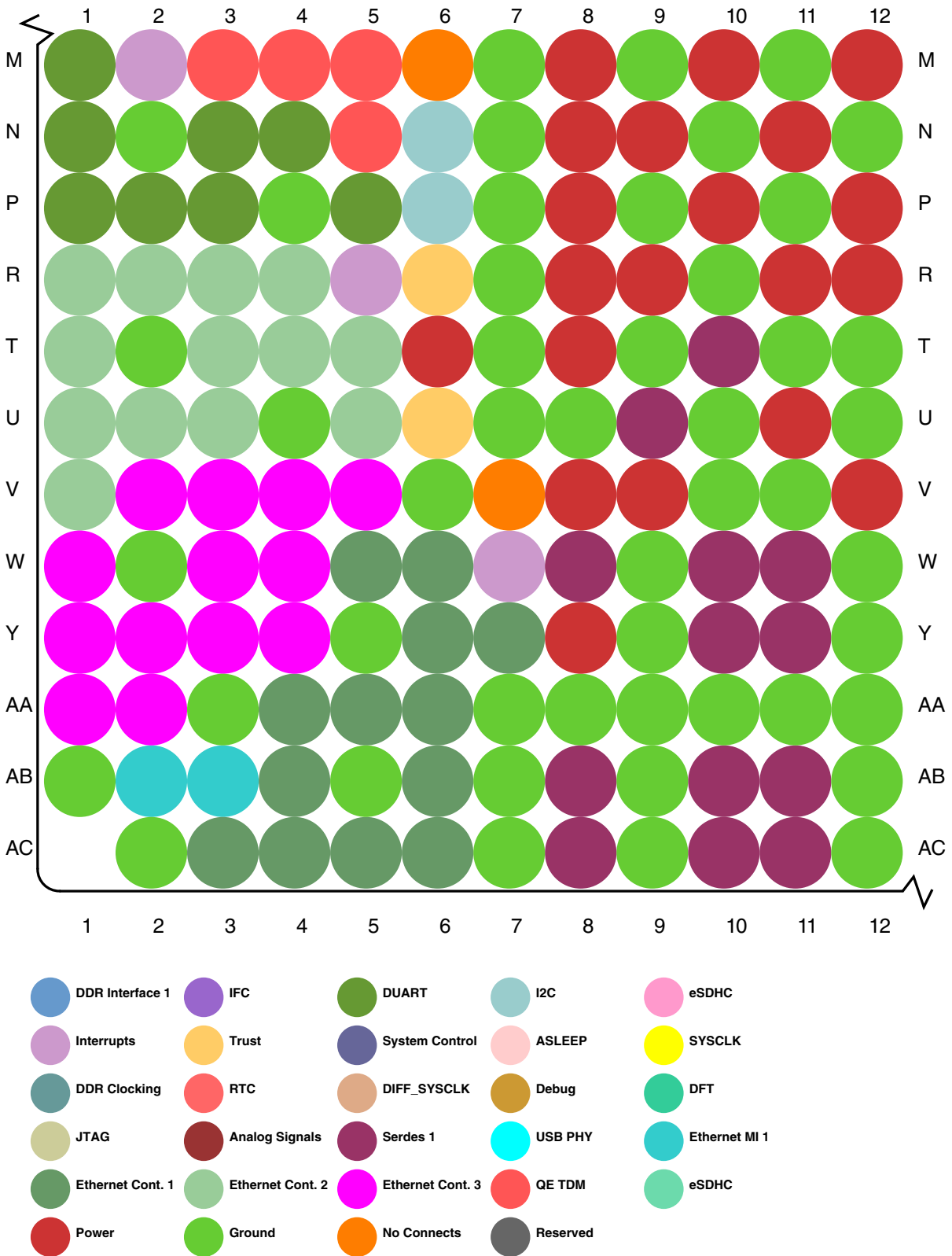

Figure 5. Detail C

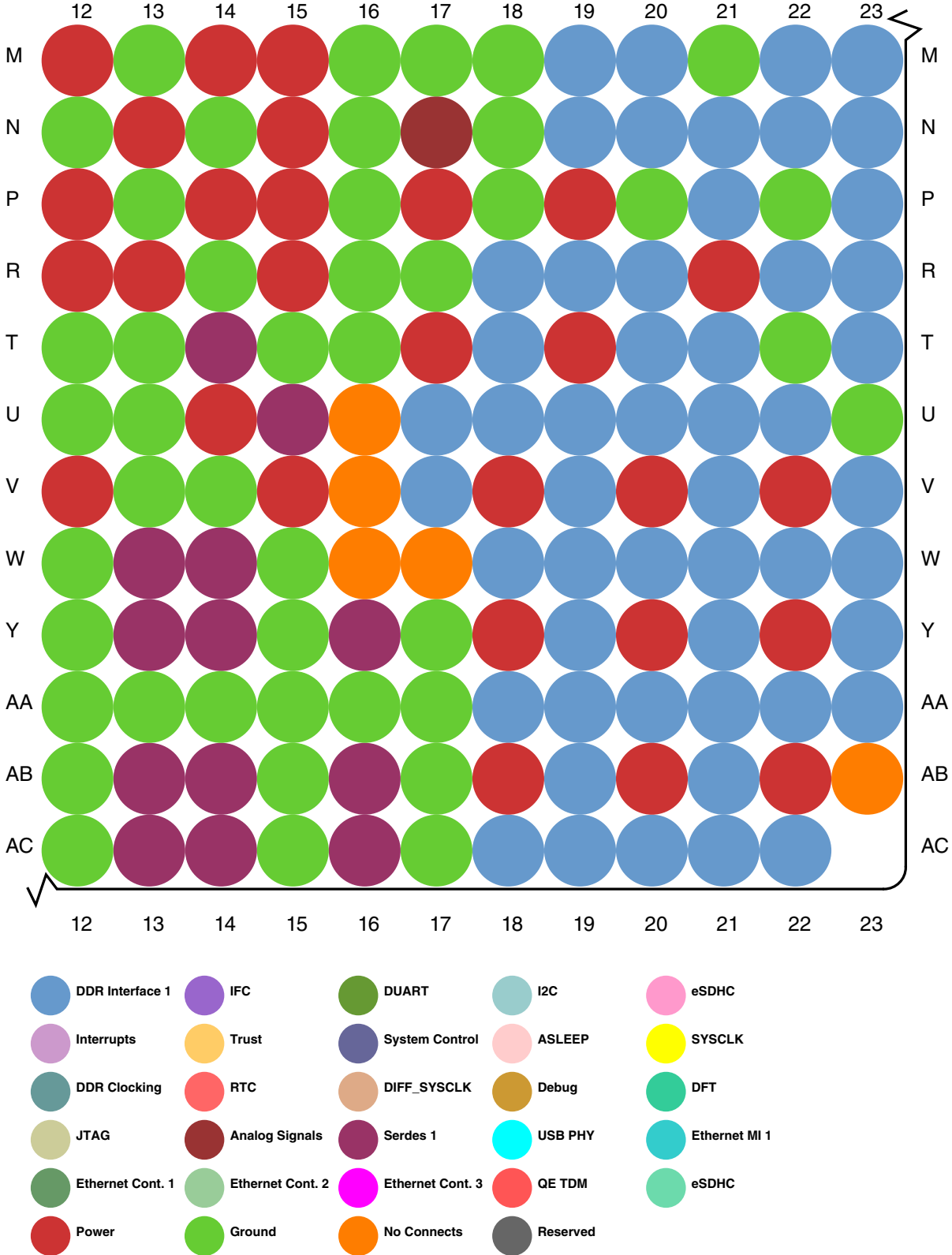

Figure 6. Detail D

2.1.2 Pinout list

This table provides the pinout listing for the LS1020A by bus. Primary functions are **bolded** in the table.

Table 1. Pinout list by bus

Signal	Signal description	Package pin number	Pin type	Power supply	Notes
DDR SDRAM Memory Interface 1					
D1_MA00	Address	AC22	O	G1V _{DD}	---
D1_MA01	Address	Y19	O	G1V _{DD}	---
D1_MA02	Address	V21	O	G1V _{DD}	---
D1_MA03	Address	AC20	O	G1V _{DD}	---
D1_MA04	Address	AA20	O	G1V _{DD}	---
D1_MA05	Address	W20	O	G1V _{DD}	---
D1_MA06	Address	AB21	O	G1V _{DD}	---
D1_MA07	Address	U20	O	G1V _{DD}	---
D1_MA08	Address	T20	O	G1V _{DD}	---
D1_MA09	Address	Y21	O	G1V _{DD}	---
D1_MA10	Address	AA19	O	G1V _{DD}	---
D1_MA11	Address	U21	O	G1V _{DD}	---
D1_MA12	Address	AA18	O	G1V _{DD}	---
D1_MA13	Address	T21	O	G1V _{DD}	---
D1_MA14	Address	AC19	O	G1V _{DD}	---
D1_MA15	Address	R18	O	G1V _{DD}	---
D1_MAPAR_ERR_B	Address Parity Error	W21	I	G1V _{DD}	1, 6
D1_MAPAR_OUT	Address Parity Out	U22	O	G1V _{DD}	---
D1_MBA0	Bank Select	AC21	O	G1V _{DD}	---
D1_MBA1	Bank Select	AA21	O	G1V _{DD}	---
D1_MBA2	Bank Select	AB19	O	G1V _{DD}	---
D1_MCAS_B	Column Address Strobe	W18	O	G1V _{DD}	---
D1_MCK0	Clock	AA22	O	G1V _{DD}	---
D1_MCK0_B	Clock Complement	AA23	O	G1V _{DD}	---
D1_MCK1	Clock	W22	O	G1V _{DD}	---
D1_MCK1_B	Clock Complement	W23	O	G1V _{DD}	---
D1_MCKE0	Clock Enable	V19	O	G1V _{DD}	2
D1_MCKE1	Clock Enable	U18	O	G1V _{DD}	2
D1_MCS0_B	Chip Select	U19	O	G1V _{DD}	---
D1_MCS1_B	Chip Select	T18	O	G1V _{DD}	---
D1_MCS2_B	Chip Select	V17	O	G1V _{DD}	---

Table continues on the next page...

Table 1. Pinout list by bus (continued)

Signal	Signal description	Package pin number	Pin type	Power supply	Notes
D1_MCS3_B	Chip Select	U17	O	G1V _{DD}	---
D1_MDIC0	Driver Impedance Calibration	V23	IO	G1V _{DD}	3
D1_MDIC1	Driver Impedance Calibration	Y23	IO	G1V _{DD}	3
D1_MDM0	Data Mask	M23	O	G1V _{DD}	1
D1_MDM1	Data Mask	L20	O	G1V _{DD}	1
D1_MDM2	Data Mask	E23	O	G1V _{DD}	1
D1_MDM3	Data Mask	E21	O	G1V _{DD}	1
D1_MDM8	Data Mask	B21	O	G1V _{DD}	1
D1_MDQ00	Data	K23	IO	G1V _{DD}	---
D1_MDQ01	Data	M22	IO	G1V _{DD}	---
D1_MDQ02	Data	R23	IO	G1V _{DD}	---
D1_MDQ03	Data	T23	IO	G1V _{DD}	---
D1_MDQ04	Data	K22	IO	G1V _{DD}	---
D1_MDQ05	Data	L23	IO	G1V _{DD}	---
D1_MDQ06	Data	P23	IO	G1V _{DD}	---
D1_MDQ07	Data	R22	IO	G1V _{DD}	---
D1_MDQ08	Data	K21	IO	G1V _{DD}	---
D1_MDQ09	Data	L21	IO	G1V _{DD}	---
D1_MDQ10	Data	N21	IO	G1V _{DD}	---
D1_MDQ11	Data	P21	IO	G1V _{DD}	---
D1_MDQ12	Data	K19	IO	G1V _{DD}	---
D1_MDQ13	Data	L19	IO	G1V _{DD}	---
D1_MDQ14	Data	N20	IO	G1V _{DD}	---
D1_MDQ15	Data	N19	IO	G1V _{DD}	---
D1_MDQ16	Data	C23	IO	G1V _{DD}	---
D1_MDQ17	Data	D23	IO	G1V _{DD}	---
D1_MDQ18	Data	H22	IO	G1V _{DD}	---
D1_MDQ19	Data	J23	IO	G1V _{DD}	---
D1_MDQ20	Data	B23	IO	G1V _{DD}	---
D1_MDQ21	Data	D22	IO	G1V _{DD}	---
D1_MDQ22	Data	G23	IO	G1V _{DD}	---
D1_MDQ23	Data	H23	IO	G1V _{DD}	---
D1_MDQ24	Data	D19	IO	G1V _{DD}	---
D1_MDQ25	Data	E20	IO	G1V _{DD}	---
D1_MDQ26	Data	H21	IO	G1V _{DD}	---
D1_MDQ27	Data	J21	IO	G1V _{DD}	---
D1_MDQ28	Data	C20	IO	G1V _{DD}	---
D1_MDQ29	Data	D21	IO	G1V _{DD}	---

Table continues on the next page...

Table 1. Pinout list by bus (continued)

Signal	Signal description	Package pin number	Pin type	Power supply	Notes
D1_MDQ30	Data	G20	IO	G1V _{DD}	---
D1_MDQ31	Data	J20	IO	G1V _{DD}	---
D1_MDQS0	Data Strobe	N23	IO	G1V _{DD}	---
D1_MDQS0_B	Data Strobe	N22	IO	G1V _{DD}	---
D1_MDQS1	Data Strobe	M19	IO	G1V _{DD}	---
D1_MDQS1_B	Data Strobe	M20	IO	G1V _{DD}	---
D1_MDQS2	Data Strobe	F23	IO	G1V _{DD}	---
D1_MDQS2_B	Data Strobe	F22	IO	G1V _{DD}	---
D1_MDQS3	Data Strobe	G21	IO	G1V _{DD}	---
D1_MDQS3_B	Data Strobe	F21	IO	G1V _{DD}	---
D1_MDQS8	Data Strobe	A21	IO	G1V _{DD}	---
D1_MDQS8_B	Data Strobe	A20	IO	G1V _{DD}	---
D1_MECC0	Error Correcting Code	B19	IO	G1V _{DD}	27
D1_MECC1	Error Correcting Code	A19	IO	G1V _{DD}	27
D1_MECC2	Error Correcting Code	C21	IO	G1V _{DD}	27
D1_MECC3	Error Correcting Code	B22	IO	G1V _{DD}	27
D1_MODT0	On Die Termination	R20	O	G1V _{DD}	2
D1_MODT1	On Die Termination	R19	O	G1V _{DD}	2
D1_MRAS_B	Row Address Strobe	AC18	O	G1V _{DD}	---
D1_MWE_B	Write Enable	W19	O	G1V _{DD}	---
Integrated Flash Controller					
IFC_A16/QSPI_CS_A0	IFC Address	C8	O	BV _{DD}	1, 5
IFC_A17/QSPI_CS_A1	IFC Address	D8	O	BV _{DD}	1, 5
IFC_A18/QSPI_CK_A	IFC Address	C9	O	BV _{DD}	1, 5
IFC_A19/QSPI_CS_B0	IFC Address	D9	O	BV _{DD}	1, 5
IFC_A20/QSPI_CS_B1	IFC Address	C10	O	BV _{DD}	1, 5
IFC_A21/QSPI_CK_B/ cfg_dram_type	IFC Address	D10	O	BV _{DD}	1, 4
IFC_A22/QSPI_DIO_A0/ IFC_WP1_B	IFC Address	C11	O	BV _{DD}	1
IFC_A23/QSPI_DIO_A1/ IFC_WP2_B	IFC Address	D11	O	BV _{DD}	1
IFC_A24/QSPI_DIO_A2/ IFC_WP3_B	IFC Address	C12	O	BV _{DD}	1
IFC_A25/GPIO2_25/ QSPI_DIO_A3/FTM5_CH0/ IFC_RB2_B/IFC_CS4_B	IFC Address	D12	O	BV _{DD}	1, 6
IFC_A26/GPIO2_26/ FTM5_CH1/IFC_RB3_B/ IFC_CS5_B	IFC Address	C13	O	BV _{DD}	1, 6

Table continues on the next page...

Table 1. Pinout list by bus (continued)

Signal	Signal description	Package pin number	Pin type	Power supply	Notes
IFC_A27/GPIO2_27/ FTM5_EXTCLK/IFC_CS6_B	IFC Address	D13	O	BV _{DD}	1, 6
IFC_AD00/cfg_gpinp0	IFC Address / Data	A7	IO	BV _{DD}	4
IFC_AD01/cfg_gpinp1	IFC Address / Data	B8	IO	BV _{DD}	4
IFC_AD02/cfg_gpinp2	IFC Address / Data	A8	IO	BV _{DD}	4
IFC_AD03/cfg_gpinp3	IFC Address / Data	B9	IO	BV _{DD}	4
IFC_AD04/cfg_gpinp4	IFC Address / Data	A9	IO	BV _{DD}	4
IFC_AD05/cfg_gpinp5	IFC Address / Data	A10	IO	BV _{DD}	4
IFC_AD06/cfg_gpinp6	IFC Address / Data	B11	IO	BV _{DD}	4
IFC_AD07/cfg_gpinp7	IFC Address / Data	A11	IO	BV _{DD}	4
IFC_AD08/cfg_rcw_src0/ SPI1_PCS1	IFC Address / Data	B12	IO	BV _{DD}	4
IFC_AD09/cfg_rcw_src1/ SPI1_PCS2	IFC Address / Data	A12	IO	BV _{DD}	4
IFC_AD10/cfg_rcw_src2/ SPI1_PCS3	IFC Address / Data	A13	IO	BV _{DD}	4
IFC_AD11/cfg_rcw_src3/ SPI1_PCS4	IFC Address / Data	B14	IO	BV _{DD}	4
IFC_AD12/cfg_rcw_src4/ SPI1_PCS5	IFC Address / Data	A14	IO	BV _{DD}	4
IFC_AD13/cfg_rcw_src5/ SPI1_SOUT	IFC Address / Data	B15	IO	BV _{DD}	4
IFC_AD14/cfg_rcw_src6	IFC Address / Data	A15	IO	BV _{DD}	4
IFC_AD15/cfg_rcw_src7	IFC Address / Data	A16	IO	BV _{DD}	4
IFC_AVD	IFC Address Valid	C16	O	BV _{DD}	1, 5
IFC_BCTL	IFC Buffer control	E14	O	BV _{DD}	2
IFC_CLE/cfg_rcw_src8	IFC Command Latch Enable / Write Enable	E17	O	BV _{DD}	1, 4
IFC_CLK0	IFC Clock	A17	O	BV _{DD}	1
IFC_CLK1	IFC Clock	B17	O	BV _{DD}	1
IFC_CS0_B	IFC Chip Select	C17	O	BV _{DD}	1, 6
IFC_CS1_B/GPIO2_10/ SPI1_PCS0/FTM7_CH0	IFC Chip Select	D17	O	BV _{DD}	1, 6
IFC_CS2_B/GPIO2_11/ SPI1_SCK/FTM7_CH1/ IIC3_SCL	IFC Chip Select	C18	O	BV _{DD}	1, 6
IFC_CS3_B/GPIO2_12/ QSPI_DIO_B3/IIC3_SDA/ FTM7_EXTCLK	IFC Chip Select	F18	O	BV _{DD}	1, 6
IFC_CS4_B/IFC_A25/ GPIO2_25/QSPI_DIO_A3/ FTM5_CH0/IFC_RB2_B	IFC Chip Select	D12	O	BV _{DD}	1

Table continues on the next page...

Table 1. Pinout list by bus (continued)

Signal	Signal description	Package pin number	Pin type	Power supply	Notes
IFC_CS5_B/IFC_A26/ GPIO2_26/FTM5_CH1/ IFC_RB3_B	IFC Chip Select	C13	O	BV _{DD}	1
IFC_CS6_B/IFC_A27/ GPIO2_27/FTM5_EXTCLK	IFC Chip Select	D13	O	BV _{DD}	1
IFC_NDDDR_CLK	IFC NAND DDR Clock	C14	O	BV _{DD}	1
IFC_NDDQS	IFC DQS Strobe	D16	IO	BV _{DD}	---
IFC_OE_B /cfg_eng_use1	IFC Output Enable	E16	O	BV _{DD}	1, 4, 5
IFC_PAR0 /GPIO2_13/ QSPI_DIO_B0/FTM6_CH0	IFC Address & Data Parity	D15	IO	BV _{DD}	---
IFC_PAR1 /GPIO2_14/ QSPI_DIO_B1/FTM6_CH1	IFC Address & Data Parity	E13	IO	BV _{DD}	---
IFC_PERR_B /GPIO2_15/ QSPI_DIO_B2/FTM6_EXTCLK	IFC Parity Error	C15	I	BV _{DD}	1, 6
IFC_RB0_B	IFC Ready / Busy CS0	F16	I	BV _{DD}	6
IFC_RB1_B /SPI1_SIN	IFC Ready / Busy CS1	F15	I	BV _{DD}	6
IFC_RB2_B/IFC_A25/ GPIO2_25/QSPI_DIO_A3/ FTM5_CH0/IFC_CS4_B	IFC Ready / Busy CS 2	D12	I	BV _{DD}	1
IFC_RB3_B/IFC_A26/ GPIO2_26/FTM5_CH1/ IFC_CS5_B	IFC Ready / Busy CS 3	C13	I	BV _{DD}	1
IFC_TE /cfg_ifc_te	IFC External Transceiver Enable	D14	O	BV _{DD}	1, 4
IFC_WE0_B /cfg_eng_use0	IFC Write Enable	F14	O	BV _{DD}	1, 22
IFC_WP0_B /cfg_eng_use2	IFC Write Protect	E18	O	BV _{DD}	1, 4, 5
IFC_WP1_B/IFC_A22/ QSPI_DIO_A0	IFC Write Protect	C11	O	BV _{DD}	1
IFC_WP2_B/IFC_A23/ QSPI_DIO_A1	IFC Write Protect	D11	O	BV _{DD}	1
IFC_WP3_B/IFC_A24/ QSPI_DIO_A2	IFC Write Protect	C12	O	BV _{DD}	1
DUART					
UART1_CTS_B /GPIO1_21/ UART3_SIN/LPUART2_SIN/ SPI2_SIN	Clear To Send	N4	I	DV _{DD}	1
UART1_RTS_B /GPIO1_19/ UART3_SOUT/ LPUART2_SOUT/SPI2_SOUT	Ready to Send	N3	O	DV _{DD}	1
UART1_SIN /GPIO1_17	Receive Data	M1	I	DV _{DD}	1
UART1_SOUT /GPIO1_15	Transmit Data	N1	O	DV _{DD}	1
UART2_CTS_B /GPIO1_22/ UART4_SIN/SPI2_SCK/	Clear To Send	P5	I	D1V _{DD}	1

Table continues on the next page...

Table 1. Pinout list by bus (continued)

Signal	Signal description	Package pin number	Pin type	Power supply	Notes
LPUART1_CTS_B/ LPUART4_SIN					
UART2_RTS_B /GPIO1_20/ UART4_SOUT/ LPUART1_RTS_B/ LPUART4_SOUT/SPI2_PCS2	Ready to Send	P3	O	D1V _{DD}	1
UART2_SIN /GPIO1_18/ LPUART1_SIN/SPI2_PCS1	Receive Data	P2	I	D1V _{DD}	1
UART2_SOUT /GPIO1_16/ SPI2_PCS0/LPUART1_SOUT	Transmit Data	P1	O	D1V _{DD}	1
UART3_SIN/ UART1_CTS_B / GPIO1_21/LPUART2_SIN/ SPI2_SIN	Receive Data	N4	I	DV _{DD}	1
UART3_SOUT/ UART1_RTS_B /GPIO1_19/ LPUART2_SOUT/SPI2_SOUT	Transmit Data	N3	O	DV _{DD}	1
UART4_SIN/ UART2_CTS_B / GPIO1_22/SPI2_SCK/ LPUART1_CTS_B/ LPUART4_SIN	Receive Data	P5	I	D1V _{DD}	1
UART4_SOUT/ UART2_RTS_B /GPIO1_20/ LPUART1_RTS_B/ LPUART4_SOUT/SPI2_PCS2	Transmit Data	P3	O	D1V _{DD}	1
LPUART					
LPUART1_CTS_B/ UART2_CTS_B /GPIO1_22/ UART4_SIN/SPI2_SCK/ LPUART4_SIN	Clear To Send	P5	I	D1V _{DD}	1
LPUART1_RTS_B/ UART2_RTS_B /GPIO1_20/ UART4_SOUT/ LPUART4_SOUT/SPI2_PCS2	Ready to Send	P3	O	D1V _{DD}	1
LPUART1_SIN/ UART2_SIN / GPIO1_18/SPI2_PCS1	Receive Data	P2	I	D1V _{DD}	1
LPUART1_SOUT/ UART2_SOUT /GPIO1_16/ SPI2_PCS0	Transmit Data	P1	O	D1V _{DD}	1
LPUART2_CTS_B/ SDHC_DAT2 /GPIO2_07/ LPUART5_SIN	Clear to Send	F1	I	EV _{DD}	1
LPUART2_RTS_B/ SDHC_DAT1 /GPIO2_06/ LPUART5_SOUT	Ready to Send	F2	O	EV _{DD}	1
LPUART2_SIN/ UART1_CTS_B /GPIO1_21/ UART3_SIN/SPI2_SIN	Receive Data	N4	I	DV _{DD}	1

Table continues on the next page...

Table 1. Pinout list by bus (continued)

Signal	Signal description	Package pin number	Pin type	Power supply	Notes
LPUART2_SOUT/ UART1_RTS_B/GPIO1_19/ UART3_SOUT/SPI2_SOUT	Transmit Data	N3	O	DV _{DD}	1
LPUART3_CTS_B/ SDHC_CLK/GPIO2_09/ LPUART6_SIN	Clear to Send	D1	I	EV _{DD}	1
LPUART3_RTS_B/ SDHC_DAT3/GPIO2_08/ LPUART6_SOUT	Ready to Send	G1	O	EV _{DD}	1
LPUART3_SIN/SDHC_DAT0/ GPIO2_05	Receive Data	E1	I	EV _{DD}	1
LPUART3_SOUT/ SDHC_CMD/GPIO2_04	Transmit Data	E2	O	EV _{DD}	1
LPUART4_SIN/ UART2_CTS_B/GPIO1_22/ UART4_SIN/SPI2_SCK/ LPUART1_CTS_B	Receive Data	P5	I	D1V _{DD}	1
LPUART4_SOUT/ UART2_RTS_B/GPIO1_20/ UART4_SOUT/ LPUART1_RTS_B/SPI2_PCS2	Transmit Data	P3	O	D1V _{DD}	1
LPUART5_SIN/SDHC_DAT2/ GPIO2_07/LPUART2_CTS_B	Receive Data	F1	I	EV _{DD}	1
LPUART5_SOUT/ SDHC_DAT1/GPIO2_06/ LPUART2_RTS_B	Transmit Data	F2	O	EV _{DD}	1
LPUART6_SIN/SDHC_CLK/ GPIO2_09/LPUART3_CTS_B	Receive Data	D1	I	EV _{DD}	1
LPUART6_SOUT/ SDHC_DAT3/GPIO2_08/ LPUART3_RTS_B	Transmit Data	G1	O	EV _{DD}	1
I2C					
IIC1_SCL	Serial Clock	N6	IO	D1V _{DD}	7, 8
IIC1_SDA	Serial Data	P6	IO	D1V _{DD}	7, 8
IIC2_SCL/GPIO4_27/ SDHC_CD_B/SPI2_PCS3	Serial Clock	K1	IO	DV _{DD}	7, 8
IIC2_SDA/GPIO4_28/ SDHC_WP/SPI2_PCS4	Serial Data	L1	IO	DV _{DD}	7, 8
IIC3_SCL/IFC_CS2_B/ GPIO2_11/SPI1_SCK/ FTM7_CH1	Serial Clock	C18	IO	BV _{DD}	---
IIC3_SDA/IFC_CS3_B/ GPIO2_12/QSPI_DIO_B3/ FTM7_EXTCLK	Serial Data	F18	IO	BV _{DD}	---
eSDHC					

Table continues on the next page...

Table 1. Pinout list by bus (continued)

Signal	Signal description	Package pin number	Pin type	Power supply	Notes
SDHC_CD_B/IIC2_SCL/ GPIO4_27/SPI2_PCS3	Command/Response	K1	I	DV _{DD}	1
SDHC_CLK/GPIO2_09/ LPUART3_CTS_B/ LPUART6_SIN	Host to Card Clock	D1	IO	EV _{DD}	---
SDHC_CMD/GPIO2_04/ LPUART3_SOUT	Command/Response	E2	IO	EV _{DD}	---
SDHC_DAT0/GPIO2_05/ LPUART3_SIN	Data	E1	IO	EV _{DD}	---
SDHC_DAT1/GPIO2_06/ LPUART2_RTS_B/ LPUART5_SOUT	Data	F2	IO	EV _{DD}	---
SDHC_DAT2/GPIO2_07/ LPUART2_CTS_B/ LPUART5_SIN	Data	F1	IO	EV _{DD}	---
SDHC_DAT3/GPIO2_08/ LPUART3_RTS_B/ LPUART6_SOUT	Data	G1	IO	EV _{DD}	---
SDHC_WP/IIC2_SDA/ GPIO4_28/SPI2_PCS4	Write Protect	L1	I	DV _{DD}	1
Programmable Interrupt Controller					
EVT9_B/GPIO2_24	Event 9	D7	IO	O1V _{DD}	6, 7
IRQ0	External Interrupt	G6	I	O1V _{DD}	1
IRQ1	External Interrupt	G8	I	OV _{DD}	1
IRQ2	External Interrupt	W7	I	L1V _{DD}	1
IRQ3/GPIO1_23	External Interrupt	R5	I	LV _{DD}	1
IRQ4/GPIO1_24/SDHC_VS	External Interrupt	L2	I	DV _{DD}	1
IRQ5/GPIO1_25/ SDHC_CLK_SYNC_IN/ SPI2_PCS5	External Interrupt	M2	I	DV _{DD}	1
Battery Backed Trust					
TA_BB_RTC	Reserved	R6	I	TA_BB_V _{DD}	1, 15
TA_BB_TMP_DETECT_B	Battery Backed Tamper Detect	U6	I	TA_BB_V _{DD}	---
TA_TMP_DETECT_B	Tamper Detect	F9	I	OV _{DD}	1
System Control					
HRESET_B	Hard Reset	E5	IO	O1V _{DD}	6, 7
PORESET_B	Power On Reset	G9	I	O1V _{DD}	24
RESET_REQ_B	Reset Request (POR or Hard)	G5	O	O1V _{DD}	1, 5
Power Management					
ASLEEP/GPIO1_13	Asleep	E6	O	O1V _{DD}	1, 5
SYSCLK					
SYSCLK	System Clock	F5	I	O1V _{DD}	---

Table continues on the next page...

Table 1. Pinout list by bus (continued)

Signal	Signal description	Package pin number	Pin type	Power supply	Notes
DDR Clocking					
DDRCLK	DDR Controller Clock	H18	I	OV _{DD}	---
RTC					
RTC/GPIO1_14	Real Time Clock	E10	I	OV _{DD}	1
DSYSCLK					
DIFF_SYSCLK	Single Source System Clock Differential (positive)	F4	I	O1V _{DD}	---
DIFF_SYSCLK_B	Single Source System Clock Differential (negative)	G4	I	O1V _{DD}	---
Debug					
CKSTP_OUT_B	Reserved	E11	O	OV _{DD}	1, 6, 7
CLK_OUT	Clock Out	C6	O	O1V _{DD}	2
EVT0_B	Event 0	C5	IO	O1V _{DD}	9
EVT1_B	Event 1	D5	IO	O1V _{DD}	---
EVT2_B	Event 2	A6	IO	O1V _{DD}	24
EVT3_B	Event 3	B6	IO	O1V _{DD}	---
EVT4_B	Event 4	C7	IO	O1V _{DD}	---
DFT					
SCAN_MODE_B	Reserved	G3	I	O1V _{DD}	10, 24
TEST_SEL_B	Reserved	F3	I	O1V _{DD}	24
JTAG					
TCK	Test Clock	E8	I	OV _{DD}	---
TDI	Test Data In	E7	I	OV _{DD}	9
TDO	Test Data Out	F7	O	OV _{DD}	2
TMS	Test Mode Select	F8	I	OV _{DD}	9
TRST_B	Test Reset	F6	I	OV _{DD}	9
Analog Signals					
D1_MVREF	SSTL Reference Voltage	L17	IO	G1V _{DD} /2	---
D1_TPA	DDR Controller 1 Test Point Analog	N17	IO	-	12
FA_ANALOG_G_V	Reserved	G13	IO	-	15
FA_ANALOG_PIN	Reserved	F12	IO	-	15
TD1_ANODE	Reserved	J6	IO	-	19
TD1_CATHODE	Reserved	K6	IO	-	19
TH_TPA	Thermal Test Point Analog	G17	-	-	12
Serdes 1					
SD1_IMP_CAL_RX	SerDes Receive Impedance Calibration	U9	I	S1V _{DD}	11

Table continues on the next page...

Table 1. Pinout list by bus (continued)

Signal	Signal description	Package pin number	Pin type	Power supply	Notes
SD1_IMP_CAL_TX	SerDes Transmit Impedance Calibration	T14	I	X1V _{DD}	16
SD1_PLL1_TPA	SerDes PLL 1 Test Point Analog	T10	O	AVDD_SD1_PLL1	12
SD1_PLL1_TPD	SerDes Test Point Digital	W8	O	X1V _{DD}	12
SD1_PLL2_TPA	SerDes PLL 2 Test Point Analog	U15	O	AVDD_SD1_PLL2	12
SD1_PLL2_TPD	SerDes Test Point Digital	Y16	O	X1V _{DD}	12
SD1_REF_CLK1_N	SerDes PLL 1 Reference Clock Complement	AB8	I	S1V _{DD}	20
SD1_REF_CLK1_P	SerDes PLL 1 Reference Clock	AC8	I	S1V _{DD}	20
SD1_REF_CLK2_N	SerDes PLL 2 Reference Clock Complement	AB16	I	S1V _{DD}	20
SD1_REF_CLK2_P	SerDes PLL 2 Reference Clock	AC16	I	S1V _{DD}	20
SD1_RX0_N	SerDes Receive Data (negative)	AB10	I	S1V _{DD}	20
SD1_RX0_P	SerDes Receive Data (positive)	AC10	I	S1V _{DD}	20
SD1_RX1_N	SerDes Receive Data (negative)	AB11	I	S1V _{DD}	20
SD1_RX1_P	SerDes Receive Data (positive)	AC11	I	S1V _{DD}	20
SD1_RX2_N	SerDes Receive Data (negative)	AB13	I	S1V _{DD}	20
SD1_RX2_P	SerDes Receive Data (positive)	AC13	I	S1V _{DD}	20
SD1_RX3_N	SerDes Receive Data (negative)	AB14	I	S1V _{DD}	20
SD1_RX3_P	SerDes Receive Data (positive)	AC14	I	S1V _{DD}	20
SD1_TX0_N	SerDes Transmit Data (negative)	Y10	O	X1V _{DD}	---
SD1_TX0_P	SerDes Transmit Data (positive)	W10	O	X1V _{DD}	---
SD1_TX1_N	SerDes Transmit Data (negative)	Y11	O	X1V _{DD}	---
SD1_TX1_P	SerDes Transmit Data (positive)	W11	O	X1V _{DD}	---
SD1_TX2_N	SerDes Transmit Data (negative)	Y13	O	X1V _{DD}	---
SD1_TX2_P	SerDes Transmit Data (positive)	W13	O	X1V _{DD}	---
SD1_TX3_N	SerDes Transmit Data (negative)	Y14	O	X1V _{DD}	---

Table continues on the next page...

Table 1. Pinout list by bus (continued)

Signal	Signal description	Package pin number	Pin type	Power supply	Notes
SD1_TX3_P	SerDes Transmit Data (positive)	W14	O	X1V _{DD}	---
USB PHY					
USB1_D_M	USB PHY Data Minus	C3	IO	-	---
USB1_D_P	USB PHY Data Plus	D3	IO	-	---
USB1_ID	USB PHY ID Detect	E3	I	-	---
USB1_RESREF	USB PHY Impedance Calibration	J7	IO	-	---
USB1_RX_M	USB PHY 3.0 Receive Data (negative)	A4	I	-	---
USB1_RX_P	USB PHY 3.0 Receive Data (positive)	B4	I	-	---
USB1_TX_M	USB PHY 3.0 Transmit Data (negative)	A2	O	-	---
USB1_TX_P	USB PHY 3.0 Transmit Data (positive)	B2	O	-	---
USB1_VBUS	USB PHY VBUS	C1	I	-	31
Ethernet Management Interface 1					
EMI1_MDC/GPIO3_00	Management Data Clock	AB2	O	L1V _{DD}	1
EMI1_MDIO/GPIO3_01	Management Data In/Out	AB3	IO	L1V _{DD}	---
Ethernet Controller 1					
EC1_GTX_CLK/GPIO3_07/ EC1_TX_CLK/ SAI2_TX_BCLK/ FTM1_EXTCLK	Transmit Clock Out	Y7	O	L1V _{DD}	1
EC1_GTX_CLK125/ GPIO3_08/EC1_RX_ER/ EXT_AUDIO_MCLK2	Reference Clock	AA4	I	L1V _{DD}	1
EC1_RXD0/GPIO3_12/ SAI2_RX_SYNC/FTM1_CH0	Receive Data	AB6	I	L1V _{DD}	1
EC1_RXD1/GPIO3_11/ SAI1_RX_SYNC/FTM1_CH1	Receive Data	AC5	I	L1V _{DD}	1
EC1_RXD2/GPIO3_10/ SAI2_RX_DATA/FTM1_CH6	Receive Data	AC4	I	L1V _{DD}	1
EC1_RXD3/GPIO3_09/ SAI1_RX_DATA/FTM1_CH4	Receive Data	AB4	I	L1V _{DD}	1
EC1_RX_CLK/GPIO3_13/ SAI1_RX_BCLK/ FTM1_QD_PHA	Receive Clock	AC3	I	L1V _{DD}	1
EC1_RX_DV/GPIO3_14/ SAI2_RX_BCLK/ FTM1_QD_PHB	Receive Data Valid	AC6	I	L1V _{DD}	1
EC1_TXD0/GPIO3_05/ SAI2_TX_SYNC/FTM1_CH2	Transmit Data	AA6	O	L1V _{DD}	1

Table continues on the next page...

Table 1. Pinout list by bus (continued)

Signal	Signal description	Package pin number	Pin type	Power supply	Notes
EC1_TXD1 /GPIO3_04/ SAI1_TX_SYNC/FTM1_CH3	Transmit Data	Y6	O	L1V _{DD}	1
EC1_TXD2 /GPIO3_03/ SAI2_TX_DATA/FTM1_CH7	Transmit Data	AA5	O	L1V _{DD}	1
EC1_TXD3 /GPIO3_02/ SAI1_TX_DATA/FTM1_CH5	Transmit Data	W5	O	L1V _{DD}	1
EC1_TX_EN /GPIO3_06/ SAI1_TX_BCLK/FTM1_FAULT	Transmit Enable	W6	O	L1V _{DD}	1, 14
Ethernet Controller 2					
EC2_GTX_CLK /GPIO3_20/ EC2_TX_CLK/USB2_CLK/ FTM2_EXTCLK	Transmit Clock Out	U3	O	LV _{DD}	1
EC2_GTX_CLK125 / GPIO3_21/EC2_RX_ER/ USB2_PWRFAULT	Reference Clock	U5	I	LV _{DD}	1
EC2_RXD0 /GPIO3_25/ USB2_D0/FTM2_CH0	Receive Data	U2	I	LV _{DD}	1
EC2_RXD1 /GPIO3_24/ USB2_D1/FTM2_CH1	Receive Data	U1	I	LV _{DD}	1
EC2_RXD2 /GPIO3_23/ USB2_D2/FTM2_CH6	Receive Data	T1	I	LV _{DD}	1
EC2_RXD3 /GPIO3_22/ USB2_D3/FTM2_CH4	Receive Data	R2	I	LV _{DD}	1
EC2_RX_CLK /GPIO3_26/ USB2_DIR/FTM2_QD_PHA	Receive Clock	R1	I	LV _{DD}	1
EC2_RX_DV /GPIO3_27/ USB2_NXT/FTM2_QD_PHB	Receive Data Valid	V1	I	LV _{DD}	1
EC2_TXD0 /GPIO3_18/ USB2_D4/FTM2_CH2	Transmit Data	T3	O	LV _{DD}	1
EC2_TXD1 /GPIO3_17/ USB2_D5/FTM2_CH3	Transmit Data	T4	O	LV _{DD}	1
EC2_TXD2 /GPIO3_16/ USB2_D6/FTM2_CH7	Transmit Data	R3	O	LV _{DD}	1
EC2_TXD3 /GPIO3_15/ USB2_D7/FTM2_CH5	Transmit Data	R4	O	LV _{DD}	1
EC2_TX_EN /GPIO3_19/ USB2_STP/FTM2_FAULT	Transmit Enable	T5	O	LV _{DD}	1, 14
Ethernet Controller 3					
EC3_GTX_CLK /GPIO4_01/ EC2_TX_ER/FTM3_CH0/ EC3_TX_CLK	Transmit Clock Out	V5	O	LV _{DD}	1
EC3_GTX_CLK125 / GPIO4_02/EC2_COL/ USB2_DRVVBUS/ EC3_RX_ER	Reference Clock	Y4	I	LV _{DD}	1

Table continues on the next page...

Table 1. Pinout list by bus (continued)

Signal	Signal description	Package pin number	Pin type	Power supply	Notes
EC3_RXD0 /GPIO4_06/ TSEC_1588_TRIG_IN2/ EC2_CRS/FTM3_CH2	Receive Data	AA1	I	LV _{DD}	1
EC3_RXD1 /GPIO4_05/ TSEC_1588_PULSE_OUT1/ FTM3_CH3	Receive Data	Y2	I	LV _{DD}	1
EC3_RXD2 /GPIO4_04/ EC1_COL/FTM3_EXTCLK	Receive Data	Y1	I	LV _{DD}	1
EC3_RXD3 /GPIO4_03/ EC1_CRS/FTM3_FAULT	Receive Data	W1	I	LV _{DD}	1
EC3_RX_CLK /GPIO4_07/ TSEC_1588_CLK_IN/ FTM3_QD_PHA	Receive Clock	V2	I	LV _{DD}	1
EC3_RX_DV /GPIO4_08/ TSEC_1588_TRIG_IN1/ FTM3_QD_PHB	Receive Data Valid	AA2	I	LV _{DD}	1
EC3_TXD0 /GPIO3_31/ TSEC_1588_PULSE_OUT2/ FTM3_CH4	Transmit Data	W4	O	LV _{DD}	1
EC3_TXD1 /GPIO3_30/ TSEC_1588_CLK_OUT/ FTM3_CH5	Transmit Data	W3	O	LV _{DD}	1
EC3_TXD2 /GPIO3_29/ TSEC_1588_ALARM_OUT1/ FTM3_CH6	Transmit Data	V4	O	LV _{DD}	1
EC3_TXD3 /GPIO3_28/ TSEC_1588_ALARM_OUT2/ FTM3_CH7	Transmit Data	V3	O	LV _{DD}	1
EC3_TX_EN /GPIO4_00/ EC1_TX_ER/FTM3_CH1	Transmit Enable	Y3	O	LV _{DD}	1, 14
TDM					
CLK09 /GPIO4_19/BRGO2/ SAI3_RX_BCLK/ FTM4_QD_PHA	External Clock	K5	I	DV _{DD}	1
CLK10 /GPIO4_20/BRGO3/ SAI3_RX_SYNC/ FTM4_QD_PHB	External Clock	L5	I	DV _{DD}	1
CLK11 /GPIO4_21/BRGO4/ SAI4_RX_SYNC/FTM8_CH0	External Clock	M5	I	DV _{DD}	1
CLK12 /GPIO4_22/BRGO1/ FTM8_CH1	External Clock	N5	I	DV _{DD}	1, 17
TDMA_RQ /GPIO4_13/ UC1_CDB_RXER/ EXT_AUDIO_MCLK1/ FTM4_CH3	Request	H5	O	DV _{DD}	1

Table continues on the next page...

Table 1. Pinout list by bus (continued)

Signal	Signal description	Package pin number	Pin type	Power supply	Notes
TDMA_RSINC /GPIO4_10/ UC1_CTSB_RXDV/ SAI3_TX_BCLK/FTM4_CH6	Receive Sync	J3	I	DV _{DD}	1
TDMA_RXD /GPIO4_09/ UC1_RXD7/SAI3_RX_DATA/ FTM4_CH7	Receive Data	H3	I	DV _{DD}	1
TDMA_TSYNC /GPIO4_12/ UC1_RTSB_TXEN/ SAI3_TX_SYNC/FTM4_CH4	Transmit Sync	J5	I	DV _{DD}	1
TDMA_TXD /GPIO4_11/ UC1_TXD7/SAI3_TX_DATA/ FTM4_CH5	Transmit Data	J4	O	DV _{DD}	1
TDMB_RQ /GPIO4_18/ UC3_CDB_RXER/ SPDIF_EXTCLK/ SAI4_RX_BCLK/ FTM4_EXTCLK	Request	K4	O	DV _{DD}	1
TDMB_RSINC /GPIO4_15/ UC3_CTSB_RXDV/ SPDIF_PLOCK/ SAI4_TX_BCLK/FTM4_CH1	Receive Sync	L3	I	DV _{DD}	1
TDMB_RXD /GPIO4_14/ UC3_RXD7/SPDIF_IN/ SAI4_RX_DATA/FTM4_CH2	Receive Data	K3	I	DV _{DD}	1
TDMB_TSYNC /GPIO4_17/ UC3_RTSB_TXEN/ SPDIF_SRCLK/ SAI4_TX_SYNC/ FTM4_FAULT	Transmit Sync	M4	I	DV _{DD}	1
TDMB_TXD /GPIO4_16/ UC3_TXD7/SPDIF_OUT/ SAI4_TX_DATA/FTM4_CH0	Transmit Data	M3	O	DV _{DD}	1
eSDHC					
SDHC_CLK_SYNC_IN /IRQ5/ GPIO1_25/SPI2_PCS5	Clock Synchronizer Input	M2	I	DV _{DD}	1
SDHC_CLK_SYNC_OUT / SDHC_DAT4 /GPIO4_23	Clock Synchronous Output	H2	O	DV _{DD}	1
SDHC_CMD_DIR / SDHC_DAT5 /GPIO4_24	Command Direction	H1	O	DV _{DD}	1
SDHC_DAT0_DIR / SDHC_DAT6 /GPIO4_25/ USB1_DRVVBUS	Data Direction	J2	O	DV _{DD}	1
SDHC_DAT123_DIR / SDHC_DAT7 /GPIO4_26/ USB1_PWRFAULT	Data Direction	J1	O	DV _{DD}	1
SDHC_DAT4 /GPIO4_23/ SDHC_CLK_SYNC_OUT	Data	H2	IO	DV _{DD}	---

Table continues on the next page...

Table 1. Pinout list by bus (continued)

Signal	Signal description	Package pin number	Pin type	Power supply	Notes
SDHC_DAT5/GPIO4_24/ SDHC_CMD_DIR	Data	H1	IO	DV _{DD}	---
SDHC_DAT6/GPIO4_25/ USB1_DRVVBUS/ SDHC_DAT0_DIR	Data	J2	IO	DV _{DD}	---
SDHC_DAT7/GPIO4_26/ USB1_PWRFAULT/ SDHC_DAT123_DIR	Data	J1	IO	DV _{DD}	---
SDHC_VS/IRQ4/GPIO1_24	VS	L2	O	DV _{DD}	1
Power-On-Reset Configuration					
cfg_dram_type/IFC_A21/ QSPI_CK_B	Power-On-Reset Configuration Signal	D10	I	BV _{DD}	1, 4
cfg_eng_use0/IFC_WE0_B	Power-On-Reset Configuration Signal	F14	I	BV _{DD}	1
cfg_gpininput0/IFC_AD00	Power-On-Reset Configuration Signal	A7	I	BV _{DD}	1, 4
cfg_gpininput1/IFC_AD01	Power-On-Reset Configuration Signal	B8	I	BV _{DD}	1, 4
cfg_gpininput2/IFC_AD02	Power-On-Reset Configuration Signal	A8	I	BV _{DD}	1, 4
cfg_gpininput3/IFC_AD03	Power-On-Reset Configuration Signal	B9	I	BV _{DD}	1, 4
cfg_gpininput4/IFC_AD04	Power-On-Reset Configuration Signal	A9	I	BV _{DD}	1, 4
cfg_gpininput5/IFC_AD05	Power-On-Reset Configuration Signal	A10	I	BV _{DD}	1, 4
cfg_gpininput6/IFC_AD06	Power-On-Reset Configuration Signal	B11	I	BV _{DD}	1, 4
cfg_gpininput7/IFC_AD07	Power-On-Reset Configuration Signal	A11	I	BV _{DD}	1, 4
cfg_ifc_te/IFC_TE	Power-On-Reset Configuration Signal	D14	I	BV _{DD}	1, 4
cfg_rcw_src0/IFC_AD08/ SPI1_PCS1	Power-On-Reset Configuration Signal	B12	I	BV _{DD}	1, 4
cfg_rcw_src1/IFC_AD09/ SPI1_PCS2	Power-On-Reset Configuration Signal	A12	I	BV _{DD}	1, 4
cfg_rcw_src2/IFC_AD10/ SPI1_PCS3	Power-On-Reset Configuration Signal	A13	I	BV _{DD}	1, 4
cfg_rcw_src3/IFC_AD11/ SPI1_PCS4	Power-On-Reset Configuration Signal	B14	I	BV _{DD}	1, 4
cfg_rcw_src4/IFC_AD12/ SPI1_PCS5	Power-On-Reset Configuration Signal	A14	I	BV _{DD}	1, 4
cfg_rcw_src5/IFC_AD13/ SPI1_SOUT	Power-On-Reset Configuration Signal	B15	I	BV _{DD}	1, 4

Table continues on the next page...

Table 1. Pinout list by bus (continued)

Signal	Signal description	Package pin number	Pin type	Power supply	Notes
cfg_rcw_src6/ IFC_AD14	Power-On-Reset Configuration Signal	A15	I	BV _{DD}	1, 4
cfg_rcw_src7/ IFC_AD15	Power-On-Reset Configuration Signal	A16	I	BV _{DD}	1, 4
cfg_rcw_src8/ IFC_CLE	Power-On-Reset Configuration Signal	E17	I	BV _{DD}	1, 4
QSPI					
QSPI_CK_A/IFC_A18	Channel A Clock	C9	O	BV _{DD}	1, 5
QSPI_CK_B/IFC_A21/ cfg_dram_type	Channel B Clock	D10	O	BV _{DD}	1, 4
QSPI_CS_A0/IFC_A16	Channel A Chip Select 0	C8	O	BV _{DD}	1, 5
QSPI_CS_A1/IFC_A17	Channel A Chip Select 1	D8	O	BV _{DD}	1, 5
QSPI_CS_B0/IFC_A19	Channel B Chip Select 0	D9	O	BV _{DD}	1, 5
QSPI_CS_B1/IFC_A20	Channel B Chip Select 1	C10	O	BV _{DD}	1, 5
QSPI_DIO_A0/IFC_A22/ IFC_WP1_B	Channel A Data I/O 0	C11	IO	BV _{DD}	---
QSPI_DIO_A1/IFC_A23/ IFC_WP2_B	Channel A Data I/O 1	D11	IO	BV _{DD}	---
QSPI_DIO_A2/IFC_A24/ IFC_WP3_B	Channel A Data I/O 2	C12	IO	BV _{DD}	---
QSPI_DIO_A3/IFC_A25/ GPIO2_25/FTM5_CH0/ IFC_RB2_B/IFC_CS4_B	Channel A Data I/O 3	D12	IO	BV _{DD}	---
QSPI_DIO_B0/IFC_PAR0/ GPIO2_13/FTM6_CH0	Channel B Data I/O 0	D15	IO	BV _{DD}	---
QSPI_DIO_B1/IFC_PAR1/ GPIO2_14/FTM6_CH1	Channel B Data I/O 1	E13	IO	BV _{DD}	---
QSPI_DIO_B2/IFC_PERR_B/ GPIO2_15/FTM6_EXTCLK	Channel B Data I/O 2	C15	IO	BV _{DD}	---
QSPI_DIO_B3/IFC_CS3_B/ GPIO2_12/IIC3_SDA/ FTM7_EXTCLK	Channel B Data I/O 3	F18	IO	BV _{DD}	---
General Purpose Input/Output					
GPIO1_13/ASLEEP	General Purpose Input/Output	E6	O	O1V _{DD}	1, 5
GPIO1_14/RTC	General Purpose Input/Output	E10	IO	OV _{DD}	---
GPIO1_15/UART1_SOUT	General Purpose Input/Output	N1	IO	DV _{DD}	---
GPIO1_16/UART2_SOUT/ SPI2_PCS0/LPUART1_SOUT	General Purpose Input/Output	P1	IO	D1V _{DD}	---
GPIO1_17/UART1_SIN	General Purpose Input/Output	M1	IO	DV _{DD}	---
GPIO1_18/UART2_SIN/ LPUART1_SIN/SPI2_PCS1	General Purpose Input/Output	P2	IO	D1V _{DD}	---

Table continues on the next page...

Table 1. Pinout list by bus (continued)

Signal	Signal description	Package pin number	Pin type	Power supply	Notes
GPIO1_19/ UART1_RTS_B / UART3_SOUT/ LPUART2_SOUT/SPI2_SOUT	General Purpose Input/Output	N3	IO	DV _{DD}	---
GPIO1_20/ UART2_RTS_B / UART4_SOUT/ LPUART1_RTS_B/ LPUART4_SOUT/SPI2_PCS2	General Purpose Input/Output	P3	IO	D1V _{DD}	---
GPIO1_21/ UART1_CTS_B / UART3_SIN/LPUART2_SIN/ SPI2_SIN	General Purpose Input/Output	N4	IO	DV _{DD}	---
GPIO1_22/ UART2_CTS_B / UART4_SIN/SPI2_SCK/ LPUART1_CTS_B/ LPUART4_SIN	General Purpose Input/Output	P5	IO	D1V _{DD}	---
GPIO1_23/ IRQ3	General Purpose Input/Output	R5	IO	LV _{DD}	---
GPIO1_24/ IRQ4 /SDHC_VS	General Purpose Input/Output	L2	IO	DV _{DD}	---
GPIO1_25/ IRQ5 / SDHC_CLK_SYNC_IN/ SPI2_PCS5	General Purpose Input/Output	M2	IO	DV _{DD}	---
GPIO2_04/ SDHC_CMD / LPUART3_SOUT	General Purpose Input/Output	E2	IO	EV _{DD}	---
GPIO2_05/ SDHC_DAT0 / LPUART3_SIN	General Purpose Input/Output	E1	IO	EV _{DD}	---
GPIO2_06/ SDHC_DAT1 / LPUART2_RTS_B/ LPUART5_SOUT	General Purpose Input/Output	F2	IO	EV _{DD}	---
GPIO2_07/ SDHC_DAT2 / LPUART2_CTS_B/ LPUART5_SIN	General Purpose Input/Output	F1	IO	EV _{DD}	---
GPIO2_08/ SDHC_DAT3 / LPUART3_RTS_B/ LPUART6_SOUT	General Purpose Input/Output	G1	IO	EV _{DD}	---
GPIO2_09/ SDHC_CLK / LPUART3_CTS_B/ LPUART6_SIN	General Purpose Input/Output	D1	IO	EV _{DD}	---
GPIO2_10/ IFC_CS1_B / SPI1_PCS0/FTM7_CH0	General Purpose Input/Output	D17	IO	BV _{DD}	---
GPIO2_11/ IFC_CS2_B / SPI1_SCK/FTM7_CH1/ IIC3_SCL	General Purpose Input/Output	C18	IO	BV _{DD}	---
GPIO2_12/ IFC_CS3_B / QSPI_DIO_B3/IIC3_SDA/ FTM7_EXTCLK	General Purpose Input/Output	F18	IO	BV _{DD}	---
GPIO2_13/ IFC_PAR0 / QSPI_DIO_B0/FTM6_CH0	General Purpose Input/Output	D15	IO	BV _{DD}	---

Table continues on the next page...

Table 1. Pinout list by bus (continued)

Signal	Signal description	Package pin number	Pin type	Power supply	Notes
GPIO2_14/ IFC_PAR1 / QSPI_DIO_B1/FTM6_CH1	General Purpose Input/Output	E13	IO	BV _{DD}	---
GPIO2_15/ IFC_PERR_B / QSPI_DIO_B2/FTM6_EXTCLK	General Purpose Input/Output	C15	IO	BV _{DD}	---
GPIO2_24/ EVT9_B	General Purpose Input/Output	D7	IO	O1V _{DD}	---
GPIO2_25/ IFC_A25 / QSPI_DIO_A3/FTM5_CH0/ IFC_RB2_B/IFC_CS4_B	General Purpose Input/Output	D12	IO	BV _{DD}	---
GPIO2_26/ IFC_A26 / FTM5_CH1/IFC_RB3_B/ IFC_CS5_B	General Purpose Input/Output	C13	IO	BV _{DD}	---
GPIO2_27/ IFC_A27 / FTM5_EXTCLK/IFC_CS6_B	General Purpose Input/Output	D13	IO	BV _{DD}	---
GPIO3_00/ EMI1_MDC	General Purpose Input/Output	AB2	IO	L1V _{DD}	---
GPIO3_01/ EMI1_MDIO	General Purpose Input/Output	AB3	IO	L1V _{DD}	---
GPIO3_02/ EC1_TXD3 / SAI1_TX_DATA/FTM1_CH5	General Purpose Input/Output	W5	IO	L1V _{DD}	---
GPIO3_03/ EC1_TXD2 / SAI2_TX_DATA/FTM1_CH7	General Purpose Input/Output	AA5	IO	L1V _{DD}	---
GPIO3_04/ EC1_TXD1 / SAI1_TX_SYNC/FTM1_CH3	General Purpose Input/Output	Y6	IO	L1V _{DD}	---
GPIO3_05/ EC1_TXD0 / SAI2_TX_SYNC/FTM1_CH2	General Purpose Input/Output	AA6	IO	L1V _{DD}	---
GPIO3_06/ EC1_TX_EN / SAI1_TX_BCLK/FTM1_FAULT	General Purpose Input/Output	W6	IO	L1V _{DD}	---
GPIO3_07/ EC1_GTX_CLK / EC1_TX_CLK/ SAI2_TX_BCLK/ FTM1_EXTCLK	General Purpose Input/Output	Y7	IO	L1V _{DD}	---
GPIO3_08/ EC1_GTX_CLK125 / EC1_RX_ER/ EXT_AUDIO_MCLK2	General Purpose Input/Output	AA4	IO	L1V _{DD}	---
GPIO3_09/ EC1_RXD3 / SAI1_RX_DATA/FTM1_CH4	General Purpose Input/Output	AB4	IO	L1V _{DD}	---
GPIO3_10/ EC1_RXD2 / SAI2_RX_DATA/FTM1_CH6	General Purpose Input/Output	AC4	IO	L1V _{DD}	---
GPIO3_11/ EC1_RXD1 / SAI1_RX_SYNC/FTM1_CH1	General Purpose Input/Output	AC5	IO	L1V _{DD}	---
GPIO3_12/ EC1_RXD0 / SAI2_RX_SYNC/FTM1_CH0	General Purpose Input/Output	AB6	IO	L1V _{DD}	---
GPIO3_13/ EC1_RX_CLK / SAI1_RX_BCLK/ FTM1_QD_PHA	General Purpose Input/Output	AC3	IO	L1V _{DD}	---

Table continues on the next page...

Table 1. Pinout list by bus (continued)

Signal	Signal description	Package pin number	Pin type	Power supply	Notes
GPIO3_14/ EC1_RX_DV / SAI2_RX_BCLK/ FTM1_QD_PHB	General Purpose Input/Output	AC6	IO	L1V _{DD}	---
GPIO3_15/ EC2_TXD3 / USB2_D7/FTM2_CH5	General Purpose Input/Output	R4	IO	LV _{DD}	---
GPIO3_16/ EC2_TXD2 / USB2_D6/FTM2_CH7	General Purpose Input/Output	R3	IO	LV _{DD}	---
GPIO3_17/ EC2_TXD1 / USB2_D5/FTM2_CH3	General Purpose Input/Output	T4	IO	LV _{DD}	---
GPIO3_18/ EC2_TXD0 / USB2_D4/FTM2_CH2	General Purpose Input/Output	T3	IO	LV _{DD}	---
GPIO3_19/ EC2_TX_EN / USB2_STP/FTM2_FAULT	General Purpose Input/Output	T5	IO	LV _{DD}	---
GPIO3_20/ EC2_GTX_CLK / EC2_TX_CLK/USB2_CLK/ FTM2_EXTCLK	General Purpose Input/Output	U3	IO	LV _{DD}	---
GPIO3_21/ EC2_GTX_CLK125 / EC2_RX_ER/ USB2_PWRFAULT	General Purpose Input/Output	U5	IO	LV _{DD}	---
GPIO3_22/ EC2_RXD3 / USB2_D3/FTM2_CH4	General Purpose Input/Output	R2	IO	LV _{DD}	---
GPIO3_23/ EC2_RXD2 / USB2_D2/FTM2_CH6	General Purpose Input/Output	T1	IO	LV _{DD}	---
GPIO3_24/ EC2_RXD1 / USB2_D1/FTM2_CH1	General Purpose Input/Output	U1	IO	LV _{DD}	---
GPIO3_25/ EC2_RXD0 / USB2_D0/FTM2_CH0	General Purpose Input/Output	U2	IO	LV _{DD}	---
GPIO3_26/ EC2_RX_CLK / USB2_DIR/FTM2_QD_PHA	General Purpose Input/Output	R1	IO	LV _{DD}	---
GPIO3_27/ EC2_RX_DV / USB2_NXT/FTM2_QD_PHB	General Purpose Input/Output	V1	IO	LV _{DD}	---
GPIO3_28/ EC3_TXD3 / TSEC_1588_ALARM_OUT2/ FTM3_CH7	General Purpose Input/Output	V3	IO	LV _{DD}	---
GPIO3_29/ EC3_TXD2 / TSEC_1588_ALARM_OUT1/ FTM3_CH6	General Purpose Input/Output	V4	IO	LV _{DD}	---
GPIO3_30/ EC3_TXD1 / TSEC_1588_CLK_OUT/ FTM3_CH5	General Purpose Input/Output	W3	IO	LV _{DD}	---
GPIO3_31/ EC3_TXD0 / TSEC_1588_PULSE_OUT2/ FTM3_CH4	General Purpose Input/Output	W4	IO	LV _{DD}	---
GPIO4_00/ EC3_TX_EN / EC1_TX_ER/FTM3_CH1	General Purpose Input/Output	Y3	IO	LV _{DD}	---

Table continues on the next page...

Table 1. Pinout list by bus (continued)

Signal	Signal description	Package pin number	Pin type	Power supply	Notes
GPIO4_01/ EC3_GTX_CLK / EC2_TX_ER/FTM3_CH0/ EC3_TX_CLK	General Purpose Input/Output	V5	IO	LV _{DD}	---
GPIO4_02/ EC3_GTX_CLK125 / EC2_COL/USB2_DRVVBUS/ EC3_RX_ER	General Purpose Input/Output	Y4	IO	LV _{DD}	---
GPIO4_03/ EC3_RXD3 / EC1_CRS/FTM3_FAULT	General Purpose Input/Output	W1	IO	LV _{DD}	---
GPIO4_04/ EC3_RXD2 / EC1_COL/FTM3_EXTCLK	General Purpose Input/Output	Y1	IO	LV _{DD}	---
GPIO4_05/ EC3_RXD1 / TSEC_1588_PULSE_OUT1/ FTM3_CH3	General Purpose Input/Output	Y2	IO	LV _{DD}	---
GPIO4_06/ EC3_RXD0 / TSEC_1588_TRIG_IN2/ EC2_CRS/FTM3_CH2	General Purpose Input/Output	AA1	IO	LV _{DD}	---
GPIO4_07/ EC3_RX_CLK / TSEC_1588_CLK_IN/ FTM3_QD_PHA	General Purpose Input/Output	V2	IO	LV _{DD}	---
GPIO4_08/ EC3_RX_DV / TSEC_1588_TRIG_IN1/ FTM3_QD_PHB	General Purpose Input/Output	AA2	IO	LV _{DD}	---
GPIO4_09/ TDMA_RXD / UC1_RXD7/SAI3_RX_DATA/ FTM4_CH7	General Purpose Input/Output	H3	IO	DV _{DD}	---
GPIO4_10/ TDMA_RSINC / UC1_CTSB_RXDV/ SAI3_TX_BCLK/FTM4_CH6	General Purpose Input/Output	J3	IO	DV _{DD}	---
GPIO4_11/ TDMA_TXD / UC1_TXD7/SAI3_TX_DATA/ FTM4_CH5	General Purpose Input/Output	J4	IO	DV _{DD}	---
GPIO4_12/ TDMA_TSYNC / UC1_RTSB_TXEN/ SAI3_TX_SYNC/FTM4_CH4	General Purpose Input/Output	J5	IO	DV _{DD}	---
GPIO4_13/ TDMA_RQ / UC1_CDB_RXER/ EXT_AUDIO_MCLK1/ FTM4_CH3	General Purpose Input/Output	H5	IO	DV _{DD}	---
GPIO4_14/ TDMB_RXD / UC3_RXD7/SPDIF_IN/ SAI4_RX_DATA/FTM4_CH2	General Purpose Input/Output	K3	IO	DV _{DD}	---
GPIO4_15/ TDMB_RSINC / UC3_CTSB_RXDV/ SPDIF_PLOCK/ SAI4_TX_BCLK/FTM4_CH1	General Purpose Input/Output	L3	IO	DV _{DD}	---

Table continues on the next page...

Table 1. Pinout list by bus (continued)

Signal	Signal description	Package pin number	Pin type	Power supply	Notes
GPIO4_16/TDMB_TXD/ UC3_TXD7/SPDIF_OUT/ SAI4_TX_DATA/FTM4_CH0	General Purpose Input/Output	M3	IO	DV _{DD}	---
GPIO4_17/TDMB_TSYNC/ UC3_RTSB_TXEN/ SPDIF_SRCLK/ SAI4_TX_SYNC/ FTM4_FAULT	General Purpose Input/Output	M4	IO	DV _{DD}	---
GPIO4_18/TDMB_RQ/ UC3_CDB_RXER/ SPDIF_EXTCLK/ SAI4_RX_BCLK/ FTM4_EXTCLK	General Purpose Input/Output	K4	IO	DV _{DD}	---
GPIO4_19/CLK09/BRGO2/ SAI3_RX_BCLK/ FTM4_QD_PHA	General Purpose Input/Output	K5	IO	DV _{DD}	---
GPIO4_20/CLK10/BRGO3/ SAI3_RX_SYNC/ FTM4_QD_PHB	General Purpose Input/Output	L5	IO	DV _{DD}	---
GPIO4_21/CLK11/BRGO4/ SAI4_RX_SYNC/FTM8_CH0	General Purpose Input/Output	M5	IO	DV _{DD}	---
GPIO4_22/CLK12/BRGO1/ FTM8_CH1	General Purpose Input/Output	N5	IO	DV _{DD}	---
GPIO4_23/SDHC_DAT4/ SDHC_CLK_SYNC_OUT	General Purpose Input/Output	H2	IO	DV _{DD}	---
GPIO4_24/SDHC_DAT5/ SDHC_CMD_DIR	General Purpose Input/Output	H1	IO	DV _{DD}	---
GPIO4_25/SDHC_DAT6/ USB1_DRVVBUS/ SDHC_DAT0_DIR	General Purpose Input/Output	J2	IO	DV _{DD}	---
GPIO4_26/SDHC_DAT7/ USB1_PWRFAULT/ SDHC_DAT123_DIR	General Purpose Input/Output	J1	IO	DV _{DD}	---
GPIO4_27/IIC2_SCL/ SDHC_CD_B/SPI2_PCS3	General Purpose Input/Output	K1	IO	DV _{DD}	---
GPIO4_28/IIC2_SDA/ SDHC_WP/SPI2_PCS4	General Purpose Input/Output	L1	IO	DV _{DD}	---
FTM1					
FTM1_CH0/EC1_RXD0/ GPIO3_12/SAI2_RX_SYNC	FTM 1 Channel 0	AB6	IO	L1V _{DD}	---
FTM1_CH1/EC1_RXD1/ GPIO3_11/SAI1_RX_SYNC	FTM 1 Channel 1	AC5	IO	L1V _{DD}	---
FTM1_CH2/EC1_TXD0/ GPIO3_05/SAI2_TX_SYNC	FTM 1 Channel 2	AA6	IO	L1V _{DD}	---
FTM1_CH3/EC1_TXD1/ GPIO3_04/SAI1_TX_SYNC	FTM 1 Channel 3	Y6	IO	L1V _{DD}	---

Table continues on the next page...

Table 1. Pinout list by bus (continued)

Signal	Signal description	Package pin number	Pin type	Power supply	Notes
FTM1_CH4/EC1_RXD3/ GPIO3_09/SAI1_RX_DATA	FTM 1 Channel 4	AB4	IO	L1V _{DD}	---
FTM1_CH5/EC1_TXD3/ GPIO3_02/SAI1_TX_DATA	FTM 1 Channel 5	W5	IO	L1V _{DD}	---
FTM1_CH6/EC1_RXD2/ GPIO3_10/SAI2_RX_DATA	FTM 1 Channel 6	AC4	IO	L1V _{DD}	---
FTM1_CH7/EC1_TXD2/ GPIO3_03/SAI2_TX_DATA	FTM 1 Channel 7	AA5	IO	L1V _{DD}	---
FTM1_EXTCLK/ EC1_GTX_CLK/GPIO3_07/ EC1_TX_CLK/SAI2_TX_BCLK	FTM 1 External Clock	Y7	I	L1V _{DD}	1
FTM1_FAULT/EC1_TX_EN/ GPIO3_06/SAI1_TX_BCLK	FTM 1 Fault	W6	I	L1V _{DD}	1
FTM1_QD_PHA/ EC1_RX_CLK/GPIO3_13/ SAI1_RX_BCLK	FTM 1 QD Phase A	AC3	I	L1V _{DD}	1
FTM1_QD_PHB/EC1_RX_DV/ GPIO3_14/SAI2_RX_BCLK	FTM 1 QD Phase B	AC6	I	L1V _{DD}	1
FTM2					
FTM2_CH0/EC2_RXD0/ GPIO3_25/USB2_D0	FTM 2 Channel 0	U2	IO	LV _{DD}	---
FTM2_CH1/EC2_RXD1/ GPIO3_24/USB2_D1	FTM 2 Channel 1	U1	IO	LV _{DD}	---
FTM2_CH2/EC2_TXD0/ GPIO3_18/USB2_D4	FTM 2 Channel 2	T3	IO	LV _{DD}	---
FTM2_CH3/EC2_TXD1/ GPIO3_17/USB2_D5	FTM 2 Channel 3	T4	IO	LV _{DD}	---
FTM2_CH4/EC2_RXD3/ GPIO3_22/USB2_D3	FTM 2 Channel 4	R2	IO	LV _{DD}	---
FTM2_CH5/EC2_TXD3/ GPIO3_15/USB2_D7	FTM 2 Channel 5	R4	IO	LV _{DD}	---
FTM2_CH6/EC2_RXD2/ GPIO3_23/USB2_D2	FTM 2 Channel 6	T1	IO	LV _{DD}	---
FTM2_CH7/EC2_TXD2/ GPIO3_16/USB2_D6	FTM 2 Channel 7	R3	IO	LV _{DD}	---
FTM2_EXTCLK/ EC2_GTX_CLK/GPIO3_20/ EC2_TX_CLK/USB2_CLK	FTM 2 External Clock	U3	I	LV _{DD}	1
FTM2_FAULT/EC2_TX_EN/ GPIO3_19/USB2_STP	FTM 2 Fault	T5	I	LV _{DD}	1
FTM2_QD_PHA/ EC2_RX_CLK/GPIO3_26/ USB2_DIR	FTM 2 QD Phase A	R1	I	LV _{DD}	1
FTM2_QD_PHB/EC2_RX_DV/ GPIO3_27/USB2_NXT	FTM 2 QD Phase B	V1	I	LV _{DD}	1

Table continues on the next page...

Table 1. Pinout list by bus (continued)

Signal	Signal description	Package pin number	Pin type	Power supply	Notes
FTM3					
FTM3_CH0/EC3_GTX_CLK/ GPIO4_01/EC2_TX_ER/ EC3_TX_CLK	FTM 3 Channel 0	V5	IO	LV _{DD}	---
FTM3_CH1/EC3_TX_EN/ GPIO4_00/EC1_TX_ER	FTM 3 Channel 1	Y3	IO	LV _{DD}	---
FTM3_CH2/EC3_RXD0/ GPIO4_06/ TSEC_1588_TRIG_IN2/ EC2_CRS	FTM 3 Channel 2	AA1	IO	LV _{DD}	---
FTM3_CH3/EC3_RXD1/ GPIO4_05/ TSEC_1588_PULSE_OUT1	FTM 3 Channel 3	Y2	IO	LV _{DD}	---
FTM3_CH4/EC3_TXD0/ GPIO3_31/ TSEC_1588_PULSE_OUT2	FTM 3 Channel 4	W4	IO	LV _{DD}	---
FTM3_CH5/EC3_TXD1/ GPIO3_30/ TSEC_1588_CLK_OUT	FTM 3 Channel 5	W3	IO	LV _{DD}	---
FTM3_CH6/EC3_TXD2/ GPIO3_29/ TSEC_1588_ALARM_OUT1	FTM 3 Channel 6	V4	IO	LV _{DD}	---
FTM3_CH7/EC3_TXD3/ GPIO3_28/ TSEC_1588_ALARM_OUT2	FTM 3 Channel 7	V3	IO	LV _{DD}	---
FTM3_EXTCLK/EC3_RXD2/ GPIO4_04/EC1_COL	FTM 3 External Clock	Y1	I	LV _{DD}	1
FTM3_FAULT/EC3_RXD3/ GPIO4_03/EC1_CRS	FTM 3 Fault	W1	I	LV _{DD}	1
FTM3_QD_PHA/ EC3_RX_CLK/GPIO4_07/ TSEC_1588_CLK_IN	FTM 3 QD Phase A	V2	I	LV _{DD}	1
FTM3_QD_PHB/EC3_RX_DV/ GPIO4_08/ TSEC_1588_TRIG_IN1	FTM 3 QD Phase B	AA2	I	LV _{DD}	1
FTM4					
FTM4_CH0/TDMB_TXD/ GPIO4_16/UC3_TXD7/ SPDIF_OUT/SAI4_TX_DATA	FTM 4 Channel 0	M3	IO	DV _{DD}	---
FTM4_CH1/TDMB_RSYNC/ GPIO4_15/UC3_CTSB_RXDV/ SPDIF_PLOCK/ SAI4_TX_BCLK	FTM 4 Channel 1	L3	IO	DV _{DD}	---
FTM4_CH2/TDMB_RXD/ GPIO4_14/UC3_RXD7/ SPDIF_IN/SAI4_RX_DATA	FTM 4 Channel 2	K3	IO	DV _{DD}	---

Table continues on the next page...

Table 1. Pinout list by bus (continued)

Signal	Signal description	Package pin number	Pin type	Power supply	Notes
FTM4_CH3/TDMA_RQ/ GPIO4_13/UC1_CDB_RXER/ EXT_AUDIO_MCLK1	FTM 4 Channel 3	H5	IO	DV _{DD}	---
FTM4_CH4/TDMA_TSYNC/ GPIO4_12/UC1_RTSB_TXEN/ SAI3_TX_SYNC	FTM 4 Channel 4	J5	IO	DV _{DD}	---
FTM4_CH5/TDMA_TXD/ GPIO4_11/UC1_TXD7/ SAI3_TX_DATA	FTM 4 Channel 5	J4	IO	DV _{DD}	---
FTM4_CH6/TDMA_RSYNC/ GPIO4_10/UC1_CTSB_RXDV/ SAI3_TX_BCLK	FTM 4 Channel 6	J3	IO	DV _{DD}	---
FTM4_CH7/TDMA_RXD/ GPIO4_09/UC1_RXD7/ SAI3_RX_DATA	FTM 4 Channel 7	H3	IO	DV _{DD}	---
FTM4_EXTCLK/TDMB_RQ/ GPIO4_18/UC3_CDB_RXER/ SPDIF_EXTCLK/ SAI4_RX_BCLK	FTM 4 External Clock	K4	I	DV _{DD}	1
FTM4_FAULT/TDMB_TSYNC/ GPIO4_17/UC3_RTSB_TXEN/ SPDIF_SRCLK/ SAI4_TX_SYNC	FTM 4 Fault	M4	I	DV _{DD}	1
FTM4_QD_PHA/CLK09/ GPIO4_19/BRGO2/ SAI3_RX_BCLK	FTM 4 QD Phase A	K5	I	DV _{DD}	1
FTM4_QD_PHB/CLK10/ GPIO4_20/BRGO3/ SAI3_RX_SYNC	FTM 4 QD Phase B	L5	I	DV _{DD}	1
FTM5					
FTM5_CH0/IFC_A25/ GPIO2_25/QSPI_DIO_A3/ IFC_RB2_B/IFC_CS4_B	FTM 5 Channel 0	D12	IO	BV _{DD}	---
FTM5_CH1/IFC_A26/ GPIO2_26/IFC_RB3_B/ IFC_CS5_B	FTM 5 Channel 1	C13	IO	BV _{DD}	---
FTM5_EXTCLK/IFC_A27/ GPIO2_27/IFC_CS6_B	FTM 5 External Clock	D13	I	BV _{DD}	1
FTM6					
FTM6_CH0/IFC_PAR0/ GPIO2_13/QSPI_DIO_B0	FTM 6 Channel 0	D15	IO	BV _{DD}	---
FTM6_CH1/IFC_PAR1/ GPIO2_14/QSPI_DIO_B1	FTM 6 Channel 1	E13	IO	BV _{DD}	---
FTM6_EXTCLK/IFC_PERR_B/ GPIO2_15/QSPI_DIO_B2	FTM 6 External Clock	C15	I	BV _{DD}	1
FTM7					

Table continues on the next page...

Table 1. Pinout list by bus (continued)

Signal	Signal description	Package pin number	Pin type	Power supply	Notes
FTM7_CH0/ IFC_CS1_B / GPIO2_10/SPI1_PCS0	FTM 7 Channel 0	D17	IO	BV _{DD}	---
FTM7_CH1/ IFC_CS2_B / GPIO2_11/SPI1_SCK/ IIC3_SCL	FTM 7 Channel 1	C18	IO	BV _{DD}	---
FTM7_EXTCLK/ IFC_CS3_B / GPIO2_12/QSPI_DIO_B3/ IIC3_SDA	FTM7 External Clock	F18	I	BV _{DD}	1
FTM8					
FTM8_CH0/ CLK11 /GPIO4_21/ BRGO4/SAI4_RX_SYNC	FTM 8 Channel 0	M5	IO	DV _{DD}	---
FTM8_CH1/ CLK12 /GPIO4_22/ BRGO1	FTM 8 Channel 1	N5	IO	DV _{DD}	---
SAI1					
EXT_AUDIO_MCLK2/ EC1_GTX_CLK125 / GPIO3_08/EC1_RX_ER	External Audio Clock (used for both SAI1 and SAI2)	AA4	I	L1V _{DD}	1
SAI1_RX_BCLK/ EC1_RX_CLK /GPIO3_13/ FTM1_QD_PHA	Receive Bit Clock	AC3	IO	L1V _{DD}	---
SAI1_RX_DATA/ EC1_RXD3 / GPIO3_09/FTM1_CH4	Receive Data	AB4	I	L1V _{DD}	1
SAI1_RX_SYNC/ EC1_RXD1 / GPIO3_11/FTM1_CH1	Receive Sync	AC5	IO	L1V _{DD}	---
SAI1_TX_BCLK/ EC1_TX_EN / GPIO3_06/FTM1_FAULT	Transmit Bit Clock	W6	IO	L1V _{DD}	---
SAI1_TX_DATA/ EC1_TXD3 / GPIO3_02/FTM1_CH5	Transmit Data	W5	O	L1V _{DD}	1
SAI1_TX_SYNC/ EC1_TXD1 / GPIO3_04/FTM1_CH3	Transmit Sync	Y6	IO	L1V _{DD}	---
SAI2					
SAI2_RX_BCLK/ EC1_RX_DV / GPIO3_14/FTM1_QD_PHB	Receive Bit Clock	AC6	IO	L1V _{DD}	---
SAI2_RX_DATA/ EC1_RXD2 / GPIO3_10/FTM1_CH6	Receive Data	AC4	I	L1V _{DD}	1
SAI2_RX_SYNC/ EC1_RXD0 / GPIO3_12/FTM1_CH0	Receive Sync	AB6	IO	L1V _{DD}	---
SAI2_TX_BCLK/ EC1_GTX_CLK /GPIO3_07/ EC1_TX_CLK/FTM1_EXTCLK	Transmit Bit Clock	Y7	IO	L1V _{DD}	---
SAI2_TX_DATA/ EC1_TXD2 / GPIO3_03/FTM1_CH7	Transmit Data	AA5	O	L1V _{DD}	1
SAI2_TX_SYNC/ EC1_TXD0 / GPIO3_05/FTM1_CH2	Transmit Sync	AA6	IO	L1V _{DD}	---
SAI3					

Table continues on the next page...

Table 1. Pinout list by bus (continued)

Signal	Signal description	Package pin number	Pin type	Power supply	Notes
EXT_AUDIO_MCLK1/ TDMA_RQ /GPIO4_13/ UC1_CDB_RXER/FTM4_CH3	External Audio Clock (used for both SAI3 and SAI4)	H5	I	DV _{DD}	1
SAI3_RX_BCLK/ CLK09 / GPIO4_19/BRGO2/ FTM4_QD_PHA	Receive Bit Clock	K5	IO	DV _{DD}	---
SAI3_RX_DATA/ TDMA_RXD / GPIO4_09/UC1_RXD7/ FTM4_CH7	Receive Data	H3	I	DV _{DD}	1
SAI3_RX_SYNC/ CLK10 / GPIO4_20/BRGO3/ FTM4_QD_PHB	Receive Sync	L5	IO	DV _{DD}	---
SAI3_TX_BCLK/ TDMA_RSYNC /GPIO4_10/ UC1_CTSB_RXDV/ FTM4_CH6	Transmit Bit Clock	J3	IO	DV _{DD}	---
SAI3_TX_DATA/ TDMA_TXD / GPIO4_11/UC1_TXD7/ FTM4_CH5	Transmit Data	J4	O	DV _{DD}	1
SAI3_TX_SYNC/ TDMA_TSYNC /GPIO4_12/ UC1_RTSB_TXEN/FTM4_CH4	Transmit Sync	J5	IO	DV _{DD}	---
SAI4					
SAI4_RX_BCLK/ TDMB_RQ / GPIO4_18/UC3_CDB_RXER/ SPDIF_EXTCLK/ FTM4_EXTCLK	Receive Bit Clock	K4	IO	DV _{DD}	---
SAI4_RX_DATA/ TDMB_RXD / GPIO4_14/UC3_RXD7/ SPDIF_IN/FTM4_CH2	Receive Data	K3	I	DV _{DD}	1
SAI4_RX_SYNC/ CLK11 / GPIO4_21/BRGO4/ FTM8_CH0	Receive Sync	M5	IO	DV _{DD}	---
SAI4_TX_BCLK/ TDMB_RSYNC /GPIO4_15/ UC3_CTSB_RXDV/ SPDIF_PLOCK/FTM4_CH1	Transmit Bit Clock	L3	IO	DV _{DD}	---
SAI4_TX_DATA/ TDMB_TXD / GPIO4_16/UC3_TXD7/ SPDIF_OUT/FTM4_CH0	Transmit Data	M3	O	DV _{DD}	1
SAI4_TX_SYNC/ TDMB_TSYNC /GPIO4_17/ UC3_RTSB_TXEN/ SPDIF_SRCLK/FTM4_FAULT	Transmit Sync	M4	IO	DV _{DD}	---
MII1					
EC1_COL/ EC3_RXD2 / GPIO4_04/FTM3_EXTCLK	Collision	Y1	I	LV _{DD}	1

Table continues on the next page...

Table 1. Pinout list by bus (continued)

Signal	Signal description	Package pin number	Pin type	Power supply	Notes
EC1_CRS/EC3_RXD3/ GPIO4_03/FTM3_FAULT	Carrier Sense	W1	I	LV _{DD}	1
EC1_RX_ER/ EC1_GTX_CLK125/ GPIO3_08/ EXT_AUDIO_MCLK2	Receive Error	AA4	I	L1V _{DD}	1
EC1_TX_CLK/ EC1_GTX_CLK/GPIO3_07/ SAI2_TX_BCLK/ FTM1_EXTCLK	Transmit Clock	Y7	I	L1V _{DD}	1
EC1_TX_ER/EC3_TX_EN/ GPIO4_00/FTM3_CH1	Transmit Error	Y3	O	LV _{DD}	1
MII2					
EC2_COL/ EC3_GTX_CLK125/ GPIO4_02/USB2_DRVVBUS/ EC3_RX_ER	Collision	Y4	I	LV _{DD}	1
EC2_CRS/EC3_RXD0/ GPIO4_06/ TSEC_1588_TRIG_IN2/ FTM3_CH2	Carrier Sense	AA1	I	LV _{DD}	1
EC2_RX_ER/ EC2_GTX_CLK125/ GPIO3_21/USB2_PWRFAULT	Receive Error	U5	I	LV _{DD}	1
EC2_TX_CLK/ EC2_GTX_CLK/GPIO3_20/ USB2_CLK/FTM2_EXTCLK	Transmit Clock	U3	I	LV _{DD}	1
EC2_TX_ER/EC3_GTX_CLK/ GPIO4_01/FTM3_CH0/ EC3_TX_CLK	Transmit Error	V5	O	LV _{DD}	1
RMI3					
EC3_RX_ER/ EC3_GTX_CLK125/ GPIO4_02/EC2_COL/ USB2_DRVVBUS	Reserved	Y4	I	LV _{DD}	1
EC3_TX_CLK/ EC3_GTX_CLK/GPIO4_01/ EC2_TX_ER/FTM3_CH0	Reserved	V5	I	LV _{DD}	1
USB Host Port 1					
USB1_DRVVBUS/ SDHC_DAT6/GPIO4_25/ SDHC_DAT0_DIR	USB1 5V Supply Enable	J2	O	DV _{DD}	1
USB1_PWRFAULT/ SDHC_DAT7/GPIO4_26/ SDHC_DAT123_DIR	USB1 Power Fault	J1	I	DV _{DD}	1
USB Host Port 2					

Table continues on the next page...

Table 1. Pinout list by bus (continued)

Signal	Signal description	Package pin number	Pin type	Power supply	Notes
USB2_CLK/EC2_GTX_CLK/ GPIO3_20/EC2_TX_CLK/ FTM2_EXTCLK	USB2 Clock	U3	I	LV _{DD}	1
USB2_D0/EC2_RXD0/ GPIO3_25/FTM2_CH0	Data	U2	IO	LV _{DD}	---
USB2_D1/EC2_RXD1/ GPIO3_24/FTM2_CH1	Data	U1	IO	LV _{DD}	---
USB2_D2/EC2_RXD2/ GPIO3_23/FTM2_CH6	Data	T1	IO	LV _{DD}	---
USB2_D3/EC2_RXD3/ GPIO3_22/FTM2_CH4	Data	R2	IO	LV _{DD}	---
USB2_D4/EC2_TXD0/ GPIO3_18/FTM2_CH2	Data	T3	IO	LV _{DD}	---
USB2_D5/EC2_TXD1/ GPIO3_17/FTM2_CH3	Data	T4	IO	LV _{DD}	---
USB2_D6/EC2_TXD2/ GPIO3_16/FTM2_CH7	Data	R3	IO	LV _{DD}	---
USB2_D7/EC2_TXD3/ GPIO3_15/FTM2_CH5	Data	R4	IO	LV _{DD}	---
USB2_DIR/EC2_RX_CLK/ GPIO3_26/FTM2_QD_PHA	USB2 Direction	R1	I	LV _{DD}	1
USB2_DRVVBUS/ EC3_GTX_CLK125/ GPIO4_02/EC2_COL/ EC3_RX_ER	USB2 5V Supply Enable	Y4	O	LV _{DD}	1
USB2_NXT/EC2_RX_DV/ GPIO3_27/FTM2_QD_PHB	USB2 Next	V1	I	LV _{DD}	1
USB2_PWRFAULT/ EC2_GTX_CLK125/ GPIO3_21/EC2_RX_ER	USB2 Power Fault	U5	I	LV _{DD}	1
USB2_STP/EC2_TX_EN/ GPIO3_19/FTM2_FAULT	USB2 Stop	T5	O	LV _{DD}	1
IEEE1588					
TSEC_1588_ALARM_OUT1/ EC3_TXD2/GPIO3_29/ FTM3_CH6	Alarm Out 1	V4	O	LV _{DD}	1
TSEC_1588_ALARM_OUT2/ EC3_TXD3/GPIO3_28/ FTM3_CH7	Alarm Out 2	V3	O	LV _{DD}	1
TSEC_1588_CLK_IN/ EC3_RX_CLK/GPIO4_07/ FTM3_QD_PHA	Clock In	V2	I	LV _{DD}	1
TSEC_1588_CLK_OUT/ EC3_TXD1/GPIO3_30/ FTM3_CH5	Clock Out	W3	O	LV _{DD}	1

Table continues on the next page...

Table 1. Pinout list by bus (continued)

Signal	Signal description	Package pin number	Pin type	Power supply	Notes
TSEC_1588_PULSE_OUT1/ EC3_RXD1/GPIO4_05/ FTM3_CH3	Pulse Out 1	Y2	O	LV _{DD}	1
TSEC_1588_PULSE_OUT2/ EC3_TXD0/GPIO3_31/ FTM3_CH4	Pulse Out 2	W4	O	LV _{DD}	1
TSEC_1588_TRIG_IN1/ EC3_RX_DV/GPIO4_08/ FTM3_QD_PHB	Trigger In 1	AA2	I	LV _{DD}	1
TSEC_1588_TRIG_IN2/ EC3_RXD0/GPIO4_06/ EC2_CRS/FTM3_CH2	Trigger In 2	AA1	I	LV _{DD}	1
BRGO					
BRGO1/CLK12/GPIO4_22/ FTM8_CH1	BRGO	N5	O	DV _{DD}	1
BRGO2/CLK09/GPIO4_19/ SAI3_RX_BCLK/ FTM4_QD_PHA	BRGO	K5	O	DV _{DD}	1
BRGO3/CLK10/GPIO4_20/ SAI3_RX_SYNC/ FTM4_QD_PHB	BRGO	L5	O	DV _{DD}	1
BRGO4/CLK11/GPIO4_21/ SAI4_RX_SYNC/FTM8_CH0	BRGO	M5	O	DV _{DD}	1
SPDIF					
SPDIF_EXTCLK/TDMB_RQ/ GPIO4_18/UC3_CDB_RXER/ SAI4_RX_BCLK/ FTM4_EXTCLK	External Clock	K4	I	DV _{DD}	1
SPDIF_IN/TDMB_RXD/ GPIO4_14/UC3_RXD7/ SAI4_RX_DATA/FTM4_CH2	SPDIF Input Line	K3	I	DV _{DD}	1
SPDIF_OUT/TDMB_TXD/ GPIO4_16/UC3_TXD7/ SAI4_TX_DATA/FTM4_CH0	SPDIF Output Line	M3	O	DV _{DD}	1
SPDIF_PLOCK/ TDMB_RSNC/GPIO4_15/ UC3_CTSB_RXDV/ SAI4_TX_BCLK/FTM4_CH1	P Lock	L3	O	DV _{DD}	1
SPDIF_SRCLK/ TDMB_TSYNC/GPIO4_17/ UC3_RTSB_TXEN/ SAI4_TX_SYNC/ FTM4_FAULT	SR Clock	M4	O	DV _{DD}	1
SPI Interface					
SPI1_PCS0/IFC_CS1_B/ GPIO2_10/FTM7_CH0	Chip Select 0	D17	IO	BV _{DD}	---

Table continues on the next page...

Table 1. Pinout list by bus (continued)

Signal	Signal description	Package pin number	Pin type	Power supply	Notes
SPI1_PCS1/IFC_AD08/ cfg_rcw_src0	Chip Select 1	B12	O	BV _{DD}	1, 4
SPI1_PCS2/IFC_AD09/ cfg_rcw_src1	Chip Select 2	A12	O	BV _{DD}	1, 4
SPI1_PCS3/IFC_AD10/ cfg_rcw_src2	Chip Select 3	A13	O	BV _{DD}	1, 4
SPI1_PCS4/IFC_AD11/ cfg_rcw_src3	Chip Select 4	B14	O	BV _{DD}	1, 4
SPI1_PCS5/IFC_AD12/ cfg_rcw_src4	Chip Select 5	A14	O	BV _{DD}	1, 4
SPI1_SCK/IFC_CS2_B/ GPIO2_11/FTM7_CH1/ IIC3_SCL	SPI Clock	C18	IO	BV _{DD}	---
SPI1_SIN/IFC_RB1_B	Serial Input	F15	I	BV _{DD}	---
SPI1_SOUT/IFC_AD13/ cfg_rcw_src5	Serial Output	B15	O	BV _{DD}	1, 4
SPI2_PCS0/UART2_SOUT/ GPIO1_16/LPUART1_SOUT	Chip Select 0	P1	IO	D1V _{DD}	---
SPI2_PCS1/UART2_SIN/ GPIO1_18/LPUART1_SIN	Chip Select 1	P2	O	D1V _{DD}	1
SPI2_PCS2/UART2_RTS_B/ GPIO1_20/UART4_SOUT/ LPUART1_RTS_B/ LPUART4_SOUT	Chip Select 2	P3	O	D1V _{DD}	1
SPI2_PCS3/IIC2_SCL/ GPIO4_27/SDHC_CD_B	Chip Select 3	K1	O	DV _{DD}	1
SPI2_PCS4/IIC2_SDA/ GPIO4_28/SDHC_WP	Chip Select 4	L1	O	DV _{DD}	1
SPI2_PCS5/IRQ5/GPIO1_25/ SDHC_CLK_SYNC_IN	Chip Select 5	M2	O	DV _{DD}	1
SPI2_SCK/UART2_CTS_B/ GPIO1_22/UART4_SIN/ LPUART1_CTS_B/ LPUART4_SIN	SPI Clock	P5	IO	D1V _{DD}	---
SPI2_SIN/UART1_CTS_B/ GPIO1_21/UART3_SIN/ LPUART2_SIN	Serial Input	N4	I	DV _{DD}	1
SPI2_SOUT/UART1_RTS_B/ GPIO1_19/UART3_SOUT/ LPUART2_SOUT	Serial Output	N3	O	DV _{DD}	1
Power and Ground Signals					
GND001	GND	A3	---	---	---
GND002	GND	A5	---	---	---
GND003	GND	A18	---	---	---
GND004	GND	A22	---	---	---

Table continues on the next page...

Table 1. Pinout list by bus (continued)

Signal	Signal description	Package pin number	Pin type	Power supply	Notes
GND005	GND	B1	---	---	---
GND006	GND	B3	---	---	---
GND007	GND	B5	---	---	---
GND008	GND	B7	---	---	---
GND009	GND	B10	---	---	---
GND010	GND	B13	---	---	---
GND011	GND	B16	---	---	---
GND012	GND	B18	---	---	---
GND013	GND	B20	---	---	---
GND014	GND	C2	---	---	---
GND015	GND	C4	---	---	---
GND016	GND	C19	---	---	---
GND017	GND	C22	---	---	---
GND018	GND	D2	---	---	---
GND019	GND	D6	---	---	---
GND020	GND	D18	---	---	---
GND021	GND	D20	---	---	---
GND022	GND	E4	---	---	---
GND023	GND	E9	---	---	---
GND024	GND	E12	---	---	---
GND025	GND	E15	---	---	---
GND026	GND	E19	---	---	---
GND027	GND	E22	---	---	---
GND028	GND	F17	---	---	---
GND029	GND	F20	---	---	---
GND030	GND	G2	---	---	---
GND031	GND	G7	---	---	---
GND032	GND	G19	---	---	---
GND033	GND	G22	---	---	---
GND034	GND	H4	---	---	---
GND035	GND	H6	---	---	---
GND036	GND	H8	---	---	---
GND037	GND	H9	---	---	---
GND038	GND	H10	---	---	---
GND039	GND	H11	---	---	---
GND040	GND	H12	---	---	---
GND041	GND	H13	---	---	---
GND042	GND	H14	---	---	---

Table continues on the next page...

Table 1. Pinout list by bus (continued)

Signal	Signal description	Package pin number	Pin type	Power supply	Notes
GND043	GND	H15	---	---	---
GND044	GND	H17	---	---	---
GND045	GND	H20	---	---	---
GND046	GND	J16	---	---	---
GND047	GND	J18	---	---	---
GND048	GND	J19	---	---	---
GND049	GND	J22	---	---	---
GND050	GND	K2	---	---	---
GND051	GND	K7	---	---	---
GND052	GND	K9	---	---	---
GND053	GND	K10	---	---	---
GND054	GND	K13	---	---	---
GND055	GND	K16	---	---	---
GND056	GND	K18	---	---	---
GND057	GND	K20	---	---	---
GND058	GND	L4	---	---	---
GND059	GND	L7	---	---	---
GND060	GND	L10	---	---	---
GND061	GND	L12	---	---	---
GND062	GND	L14	---	---	---
GND063	GND	L16	---	---	---
GND064	GND	L18	---	---	---
GND065	GND	L22	---	---	---
GND066	GND	M7	---	---	---
GND067	GND	M9	---	---	---
GND068	GND	M11	---	---	---
GND069	GND	M13	---	---	---
GND070	GND	M16	---	---	---
GND071	GND	M17	---	---	---
GND072	GND	M18	---	---	---
GND073	GND	M21	---	---	---
GND074	GND	N2	---	---	---
GND075	GND	N7	---	---	---
GND076	GND	N10	---	---	---
GND077	GND	N12	---	---	---
GND078	GND	N14	---	---	---
GND079	GND	N16	---	---	---
GND080	GND	N18	---	---	---

Table continues on the next page...

Table 1. Pinout list by bus (continued)

Signal	Signal description	Package pin number	Pin type	Power supply	Notes
GND081	GND	P4	---	---	---
GND082	GND	P7	---	---	---
GND083	GND	P9	---	---	---
GND084	GND	P11	---	---	---
GND085	GND	P13	---	---	---
GND086	GND	P16	---	---	---
GND087	GND	P18	---	---	---
GND088	GND	P20	---	---	---
GND089	GND	P22	---	---	---
GND090	GND	R7	---	---	---
GND091	GND	R10	---	---	---
GND092	GND	R14	---	---	---
GND093	GND	R16	---	---	---
GND094	GND	R17	---	---	---
GND095	GND	T2	---	---	---
GND096	GND	T7	---	---	---
GND097	GND	T16	---	---	---
GND098	GND	T22	---	---	---
GND099	GND	U4	---	---	---
GND100	GND	U8	---	---	---
GND101	GND	U23	---	---	---
GND102	GND	V6	---	---	---
GND103	GND	W2	---	---	---
GND104	GND	Y5	---	---	---
GND105	GND	Y17	---	---	---
GND106	GND	AA3	---	---	---
GND107	GND	AB1	---	---	---
GND108	GND	AB5	---	---	---
GND109	GND	AC2	---	---	---
X1GND01	Serdes1 transceiver GND	V10	---	---	---
X1GND02	Serdes1 transceiver GND	V11	---	---	---
X1GND03	Serdes1 transceiver GND	V13	---	---	---
X1GND04	Serdes1 transceiver GND	V14	---	---	---
X1GND05	Serdes1 transceiver GND	W9	---	---	---
X1GND06	Serdes1 transceiver GND	W12	---	---	---
X1GND07	Serdes1 transceiver GND	W15	---	---	---
X1GND08	Serdes1 transceiver GND	Y9	---	---	---
X1GND09	Serdes1 transceiver GND	Y12	---	---	---

Table continues on the next page...

Table 1. Pinout list by bus (continued)

Signal	Signal description	Package pin number	Pin type	Power supply	Notes
X1GND10	Serdes1 transceiver GND	Y15	---	---	---
S1GND01	Serdes core logic GND	T9	---	---	---
S1GND02	Serdes core logic GND	T11	---	---	---
S1GND03	Serdes core logic GND	T12	---	---	---
S1GND04	Serdes core logic GND	T13	---	---	---
S1GND05	Serdes core logic GND	T15	---	---	---
S1GND06	Serdes core logic GND	U12	---	---	---
S1GND07	Serdes core logic GND	AA7	---	---	---
S1GND08	Serdes core logic GND	AA8	---	---	---
S1GND09	Serdes core logic GND	AA9	---	---	---
S1GND10	Serdes core logic GND	AA10	---	---	---
S1GND11	Serdes core logic GND	AA11	---	---	---
S1GND12	Serdes core logic GND	AA12	---	---	---
S1GND13	Serdes core logic GND	AA13	---	---	---
S1GND14	Serdes core logic GND	AA14	---	---	---
S1GND15	Serdes core logic GND	AA15	---	---	---
S1GND16	Serdes core logic GND	AA16	---	---	---
S1GND17	Serdes core logic GND	AA17	---	---	---
S1GND18	Serdes core logic GND	AB7	---	---	---
S1GND19	Serdes core logic GND	AB9	---	---	---
S1GND20	Serdes core logic GND	AB12	---	---	---
S1GND21	Serdes core logic GND	AB15	---	---	---
S1GND22	Serdes core logic GND	AB17	---	---	---
S1GND23	Serdes core logic GND	AC7	---	---	---
S1GND24	Serdes core logic GND	AC9	---	---	---
S1GND25	Serdes core logic GND	AC12	---	---	---
S1GND26	Serdes core logic GND	AC15	---	---	---
S1GND27	Serdes core logic GND	AC17	---	---	---
AGND_SD1_PLL1	Serdes1 PLL 1 GND	U10	---	---	---
AGND_SD1_PLL2	Serdes1 PLL 2 GND	U13	---	---	---
SENSEGND	GND Sense pin	G16	---	---	---
SENSEGNDC	GND Sense pin for VDDC domain	U7	---	---	---
O1VDD1	General I/O supply - always on	J10	---	O1V _{DD}	---
O1VDD2	General I/O supply - always on	J11	---	O1V _{DD}	---
OVDD	General I/O supply - switchable	J12	---	OV _{DD}	---
BVDD1	IFC/QSPI/SPI1 I/O supply - switchable	J13	---	BV _{DD}	---

Table continues on the next page...

Table 1. Pinout list by bus (continued)

Signal	Signal description	Package pin number	Pin type	Power supply	Notes
BVDD2	IFC/QSPI/SPI1 I/O supply - switchable	J14	---	BV _{DD}	---
BVDD3	IFC/QSPI/SPI1 I/O supply - switchable	J15	---	BV _{DD}	---
D1VDD	UART/I2C supply - always on	M8	---	D1V _{DD}	---
DVDD1	UART/I2C/QE supply - switchable	L8	---	DV _{DD}	---
DVDD2	UART/I2C/QE supply - switchable	L9	---	DV _{DD}	---
EVDD	eSDHC supply - switchable	K8	---	EV _{DD}	---
L1VDD1	Ethernet controller 1 supply - always on	R8	---	L1V _{DD}	---
L1VDD2	Ethernet controller 1 supply - always on	T8	---	L1V _{DD}	---
LVDD1	Ethernet controller 2 & 3 supply - switchable	N8	---	LV _{DD}	---
LVDD2	Ethernet controller 2 & 3 supply - switchable	P8	---	LV _{DD}	---
G1VDD01	DDR supply - switchable	K15	---	G1V _{DD}	---
G1VDD02	DDR supply - switchable	L15	---	G1V _{DD}	---
G1VDD03	DDR supply - switchable	M15	---	G1V _{DD}	---
G1VDD04	DDR supply - switchable	N15	---	G1V _{DD}	---
G1VDD05	DDR supply - switchable	P15	---	G1V _{DD}	---
G1VDD06	DDR supply - switchable	P17	---	G1V _{DD}	---
G1VDD07	DDR supply - switchable	P19	---	G1V _{DD}	---
G1VDD08	DDR supply - switchable	R15	---	G1V _{DD}	---
G1VDD09	DDR supply - switchable	R21	---	G1V _{DD}	---
G1VDD10	DDR supply - switchable	T17	---	G1V _{DD}	---
G1VDD11	DDR supply - switchable	T19	---	G1V _{DD}	---
G1VDD12	DDR supply - switchable	V18	---	G1V _{DD}	---
G1VDD13	DDR supply - switchable	V20	---	G1V _{DD}	---
G1VDD14	DDR supply - switchable	V22	---	G1V _{DD}	---
G1VDD15	DDR supply - switchable	Y18	---	G1V _{DD}	---
G1VDD16	DDR supply - switchable	Y20	---	G1V _{DD}	---
G1VDD17	DDR supply - switchable	Y22	---	G1V _{DD}	---
G1VDD18	DDR supply - switchable	AB18	---	G1V _{DD}	---
G1VDD19	DDR supply - switchable	AB20	---	G1V _{DD}	---
G1VDD20	DDR supply - switchable	AB22	---	G1V _{DD}	---
S1VDD1	SerDes1 core logic supply	R11	---	S1V _{DD}	---
S1VDD2	SerDes1 core logic supply	R12	---	S1V _{DD}	---

Table continues on the next page...

Table 1. Pinout list by bus (continued)

Signal	Signal description	Package pin number	Pin type	Power supply	Notes
S1VDD3	SerDes1 core logic supply	R13	---	S1V _{DD}	---
X1VDD1	SerDes1 transceiver supply	V9	---	X1V _{DD}	---
X1VDD2	SerDes1 transceiver supply	V12	---	X1V _{DD}	---
X1VDD3	SerDes1 transceiver supply	V15	---	X1V _{DD}	---
X1VDD4	SerDes1 transceiver supply	Y8	---	X1V _{DD}	---
FA_VL	Reserved	G12	---	FA_VL	15
PROG_MTR	Reserved	F10	---	PROG_MTR	15
TA_PROG_SFP	SFP Fuse Programming	F11	---	TA_PROG_SFP	23
TH_VDD	Thermal monitor unit supply	G15	---	TH_V _{DD}	28
VDD01	Supply for cores and platform	K12	---	V _{DD}	---
VDD02	Supply for cores and platform	K14	---	V _{DD}	---
VDD03	Supply for cores and platform	L11	---	V _{DD}	---
VDD04	Supply for cores and platform	L13	---	V _{DD}	---
VDD05	Supply for cores and platform	M12	---	V _{DD}	---
VDD06	Supply for cores and platform	M14	---	V _{DD}	---
VDD07	Supply for cores and platform	N9	---	V _{DD}	---
VDD08	Supply for cores and platform	N11	---	V _{DD}	---
VDD09	Supply for cores and platform	N13	---	V _{DD}	---
VDD10	Supply for cores and platform	P12	---	V _{DD}	---
VDD11	Supply for cores and platform	P14	---	V _{DD}	---
VDDC1	Always ON supply	K11	---	V _{DDC}	---
VDDC2	Always ON supply	M10	---	V _{DDC}	---
VDDC3	Always ON supply	P10	---	V _{DDC}	---
VDDC4	Always ON supply	R9	---	V _{DDC}	---
TA_BB_VDD	Battery Backed Security Monitor Supply	T6	---	TA_BB_V _{DD}	---
AVDD_CGA1	CPU Cluster Group A PLL1 supply	G11	---	AVDD_CGA1	---
AVDD_PLAT	Platform PLL supply	G10	---	AVDD_PLAT	---
AVDD_D1	DDR1 PLL supply	K17	---	AVDD_D1	---
AVDD_SD1_PLL1	SerDes1 PLL 1 supply	U11	---	AVDD_SD1_PLL1	---
AVDD_SD1_PLL2	SerDes1 PLL 2 supply	U14	---	AVDD_SD1_PLL2	---
SENSEVDD	Vdd Sense pin	H16	---	SENSEVDD	---
SENSEVDDC	Vddc Sense pin	V8	---	SENSEVDDC	---
USB_HVDD	3.3V High Supply	D4	---	USB_HV _{DD}	---
USB1_SDVDD	Analog and digital HS supply	H7	---	USB1_SDV _{DD}	---
USB1_SPVDD	Analog and digital SS supply	J9	---	USB1_SPV _{DD}	---
USB1_SXVDD	Transmit supply	J8	---	USB1_SXV _{DD}	---
No Connection Pins					

Table continues on the next page...

Table 1. Pinout list by bus (continued)

Signal	Signal description	Package pin number	Pin type	Power supply	Notes
NC_F19	No Connection	F19	---	---	12
NC_G18	No Connection	G18	---	---	12
NC_H19	No Connection	H19	---	---	12
NC_J17	No Connection	J17	---	---	12
NC_L6	No Connection	L6	---	---	12
NC_M6	No Connection	M6	---	---	12
NC_U16	No Connection	U16	---	---	12
NC_V7	No Connection	V7	---	---	12
NC_V16	No Connection	V16	---	---	12
NC_W16	No Connection	W16	---	---	12
NC_W17	No Connection	W17	---	---	12
NC_DET	No Connection	AB23	---	---	12
Reserved Pins					
SPARE1	---	G14	---	---	19
SPARE2	---	F13	---	---	19

1. Functionally, this pin is an output or an input, but structurally it is an I / O because it either sample configuration input during reset, is a muxed pin, or has other manufacturing test functions. This pin will therefore be described as an I / O for boundary scan.

2. This output is actively driven during reset rather than being tri-stated during reset.

3. MDIC[0] is grounded through an 162Ω precision 1% resistor and MDIC[1] is connected to GV_{DD} through an 162Ω precision 1% resistor. For either full or half driver strength calibration of DDR IOs, use the same MDIC resistor value of 162Ω. Memory controller register setting can be used to determine automatic calibration is done to full or half drive strength. These pins are used for automatic calibration of the DDR3L/DDR4 IOs. The MDIC[0:1] pins must be connected to 162Ω precision 1% resistors.

4. This pin is a reset configuration pin. It has a weak (~20 kΩ) internal pull-up P-FET that is enabled only when the processor is in its reset state. The internal pull-up resistor value for applicable IFC pins is ~33kΩ. This pull-up is designed such that it can be overpowered by an external 4.7 kΩ resistor. However, if the signal is intended to be high after reset, and if there is any device on the net that might pull down the value of the net at reset, a pull-up or active driver is needed.

5. Pin must **NOT** be pulled down during power-on reset. This pin may be pulled up, driven high, or if there are any externally connected devices, left in tristate. If this pin is connected to a device that pulls down during reset, an external pull-up is required to drive this pin to a safe state during reset.
6. Recommend that a weak pull-up resistor (2-10 k Ω) be placed on this pin to the respective power supply.
7. This pin is an open-drain signal.
8. Recommend that a weak pull-up resistor (1 k Ω) be placed on this pin to the respective power supply.
9. This pin has a weak (~20 k Ω) internal pull-up P-FET that is always enabled.
10. These are test signals for factory use only and must be pulled up (100 Ω to 1-k Ω) to the respective power supply for normal operation.
11. This pin requires a 200 Ω pull-up to respective power-supply.
12. Do not connect. These pins should be left floating.
14. This pin requires an external 1-k Ω pull-down resistor to prevent PHY from seeing a valid Transmit Enable before it is actively driven.
15. These pins must be pulled to ground (GND).
16. This pin requires a 698 Ω pull-up to respective power-supply.
17. CLK12 is connected to CLK8 internally.
19. Do not connect.
20. These pins must be connected to S1GND.
22. This pin has a weak (~20 k Ω) internal pull-up P-FET that is enabled only when the processor is in its reset state. This pin should have an optional pull down resistor on board. This is required to support DIFF_SYSCLK/DIFF_SYSCLK_B.
23. Connect to ground when fuses are read-only.
24. For boundary scan, TEST_SEL_B and PORESET_B pins must be pulled to ground (GND), and SCAN_MODE_B and EVT2_B pins must be pulled up.
27. The prime DQ bit of the DRAM must connect to 1 of the ECC[0:3] pins. In addition, if using a 16-bit data bus in DDR4 mode, then DQ[0:1] of the DRAM must connect to ECC[0:1] pins. The prime DQ bit of the DRAM is defined as DQ[0] for some DRAM vendors and any of DQ bits for other DRAM vendors.

- 28. TH_V_{DD} must be tied to the recommended supply level per the Recommended operating conditions section.
- 31. The permissible voltage range is 0-5.5 V.

Warning

See "**Connection Recommendations**" for additional details on properly connecting these pins for specific applications.

3 Electrical characteristics

This section describes the DC and AC electrical specifications for the chip. The chip is currently targeted to these specifications, some of which are independent of the I/O cell but are included for a more complete reference. These are not purely I/O buffer design specifications.

3.1 Overall DC electrical characteristics

This section describes the ratings, conditions, and other characteristics.

3.1.1 Absolute maximum ratings

This table provides the absolute maximum ratings.

Table 2. Absolute maximum ratings¹

Characteristic	Symbol	Max Value	Unit	Notes
Core and platform supply voltage	V _{DD}	-0.3 to 1.03	V	9
Always ON supply voltage	V _{DDC}	-0.3 to 1.03	V	—
PLL supply voltage (core PLL/eSDHC, platform, DDR)	AV _{DD_CGA1} AV _{DD_PLAT} AV _{DD_D1}	-0.3 to 1.98	V	11
PLL supply voltage (SerDes, filtered from X1V _{DD})	AV _{DD_SD1_PLL1} AV _{DD_SD1_PLL2}	-0.3 to 1.48	V	—
SFP Fuse Programming	TA_PROG_SFP	-0.3 to 1.98	V	—
Thermal monitor unit supply	TH_V _{DD}	-0.3 to 1.98	V	
System control and power management, GPIO1, GPIO2, debug, and IRQ	O1V _{DD}	-0.3 to 1.98	V	—
Clocking, debug, DDRCLK supply, JTAG, RTC, and IRQ	OV _{DD}	-0.3 to 1.98	V	—

Table continues on the next page...

Table 2. Absolute maximum ratings¹ (continued)

Characteristic	Symbol	Max Value	Unit	Notes	
DUART, I ² C, DMA, TDM, QE, LPUART1, 2, 4, GPIO1, eSDHC, SAI(I ² S) 3, 4, SPDIF, FTM4, FTM8, SPI2, IRQ	D1V _{DD}	-0.3 to 3.63	V	10	
	DV _{DD}	-0.3 to 1.98			
QSPI, SPI1, IFC, GPIO2, FTM5, FTM6, FTM7, I ² C	BV _{DD}	-0.3 to 3.63	V	—	
		-0.3 to 1.98			
GPIO2, eSDHC, LPUART3, 5, 6	EV _{DD}	-0.3 to 3.63	V	—	
		-0.3 to 1.98			
DDR4 and DDR3L DRAM I/O voltage	G1V _{DD}	-0.3 to 1.48	V	—	
		-0.3 to 1.32			
Main power supply for internal circuitry of SerDes and pad power supply for SerDes receivers	S1V _{DD}	-0.3 to 1.03	V	—	
Pad power supply for SerDes transmitter	X1V _{DD}	-0.3 to 1.48	V	—	
Ethernet interface 2 and 3, 1588, GPIO1, GPIO3, USB2, FTM2, FTM3, Ethernet management interface 1 (EMI1)	LV _{DD}	-0.3 to 3.63	V	—	
		-0.3 to 2.75			
		-0.3 to 1.98			
Ethernet interface 1, GPIO3, SAI(I ² S) 1, 2, FTM1	L1V _{DD}	-0.3 to 3.63	V	—	
		-0.3 to 2.75			
		-0.3 to 1.98			
USB PHY Transceiver supply voltage	USB_HV _{DD}	-0.3 to 3.63	V	—	
	USB1_SDV _{DD}	-0.3 to 1.03	V	—	
	USB1_SXV _{DD}	-0.3 to 1.03	V	—	
USB PHY Analog supply voltage	USB1_SPV _{DD}	-0.3 to 1.03	V	—	
Battery Backed Security Monitor supply	TA_BB_V _{DD}	-0.3 to 1.03	V	—	
Input voltage	DDR4 and DDR3L DRAM signals	MV _{IN}	-0.3 to (G1V _{DD} + 0.3)	V	2, 12
	DDR4 and DDR3L DRAM reference	D1_MV _{REF}	-0.3 to (G1V _{DD} /2 + 0.3)	V	5
	Ethernet interface 2 and 3, Ethernet management interface 1 (EMI1), 1588, GPIO1, GPIO3, USB2, FTM2, FTM3	LV _{IN}	-0.3 to (LV _{DD} + 0.3)	V	4, 5
	Ethernet interface 1, GPIO3, SAI(I ² S) 1, 2, FTM1	L1V _{IN}	-0.3 to (L1V _{DD} + 0.3)	V	4, 5
	Clocking, debug, DDRCLK supply, JTAG, RTC, IRQ	OV _{IN}	-0.3 to (OV _{DD} + 0.3)	V	3, 5
	System control and power management, GPIO1, GPIO2, debug, IRQ	O1V _{IN}	-0.3 to (O1V _{DD} + 0.3)	V	3, 5
	GPIO2, eSDHC, LPUART3, 5, 6 signals	EV _{IN}	-0.3 to (EV _{DD} + 0.3)	V	5, 6, 7
	QSPI, SPI1, IFC, GPIO2, FTM5, FTM6, FTM7, I ² C signals	BV _{IN}	-0.3 to (BV _{DD} + 0.3)	V	5, 8
	DUART, I ² C, DMA, TDM, QE, LPUART1, 2, 4, GPIO1, eSDHC, SAI(I ² S) 3, 4, SPDIF, FTM4, FTM8, SPI2, IRQ	DV _{IN}	-0.3 to (DnV _{DD} + 0.3)	V	5, 6, 10
		D1V _{IN}			
	SerDes signals	S1V _{IN}	-0.4 to (S1V _{DD} + 0.3)	V	5
	USB PHY Transceiver signals	USB_HV _{IN}	-0.3 to (USB_HV _{DD} + 0.3)	V	5

Table continues on the next page...

Table 2. Absolute maximum ratings¹ (continued)

Characteristic	Symbol	Max Value	Unit	Notes
Storage temperature range	T _{STG}	-55 to 150	°C	—
Notes:				
1. Functional operating conditions are given in Table 3 . Absolute maximum ratings are stress ratings only, and functional operation at the maximums is not guaranteed. Stresses beyond those listed may affect device reliability or cause permanent damage to the device.				
2. Caution: MV _{IN} must not exceed GV _{DD} by more than 0.3 V. This limit may be exceeded for a maximum of 20 ms during power-on reset and power-down sequences.				
3. Caution: OV _{IN} must not exceed OV _{DD} by more than 0.3 V. This limit may be exceeded for a maximum of 20 ms during power-on reset and power-down sequences.				
4. Caution: LV _{IN} must not exceed LV _{DD} by more than 0.3 V. This limit may be exceeded for a maximum of 20 ms during power-on reset and power-down sequences.				
5. (S,B,L,O,D,E)V _{IN} , USBn_HV _{IN} , and Dn_MV _{REF} may overshoot/undershoot to a voltage and for a maximum duration as shown in Figure 7 .				
6. Caution: DV _{IN} must not exceed DV _{DD} by more than 0.3 V. This limit may be exceeded for a maximum of 20 ms during power-on reset and power-down sequences.				
7. Caution: EV _{IN} must not exceed EV _{DD} by more than 0.3 V. This limit may be exceeded for a maximum of 20 ms during power-on reset and power-down sequences.				
8. Caution: BV _{IN} must not exceed BV _{DD} by more than 0.3 V. This limit may be exceeded for a maximum of 20 ms during power-on reset and power-down sequences.				
9. Supply voltage specified at the voltage sense pin. Voltage input pins should be regulated to provide specified voltage at the sense pin.				
10. See the power supply column in Table 1 to determine which power supply rail is used for each interface.				
11. AVDD_PLAT, AVDD_CGA1 and AVDD_D1 are measured at the input to the filter (as shown in AN4971) and not at the pin of the device.				
12. Typical DDR interface uses ODT enabled mode. For tests purposes with ODT off mode, simulation should be done first so as to make sure that the overshoot signal level at the input pin does not exceed GV _{DD} by more than 10%. The overshoot/undershoot period should comply with JEDEC standards.				

3.1.2 Recommended operating conditions

This table provides the recommended operating conditions for this chip.

NOTE

The values shown are the recommended operating conditions and proper device operation outside these conditions is not guaranteed.

Table 3. Recommended operating conditions

Characteristic	Symbol	Power domain in deep sleep	Recommended Value	Unit	Notes
Core and platform supply voltage	V _{DD}	OFF	1.0 V ± 30 mV	V	3, 4, 5

Table continues on the next page...

Table 3. Recommended operating conditions (continued)

Characteristic		Symbol	Power domain in deep sleep	Recommended Value	Unit	Notes
Always ON core and platform supply		V _{DDC}	ON	1.0 V ± 30 mV	V	
Battery backed security monitor supply		TA_BB_V _{DD}	OFF	1.0 V ± 30 mV	V	—
PLL supply voltage (core PLL/eSDHC, platform, DDR)		AV _{DD_CGA1} AV _{DD_PLAT} AV _{DD_D1}	OFF ON OFF	1.8 V ± 90 mV	V	—
PLL supply voltage (SerDes, filtered from X1V _{DD})		AV _{DD_SD1_PLL} 1 AV _{DD_SD1_PLL} 2	OFF OFF	1.35 V ± 67 mV	V	—
SFP Fuse Programming		TA_PROG_SFP	Refer to table note	1.8 V ± 90 mV	V	2
Thermal monitor unit supply		TH_V _{DD}	OFF	1.8 V ± 90 mV	V	
Clocking, debug, DDRCLK supply, JTAG, RTC, IRQ		OV _{DD}	OFF	1.8 V ± 90 mV	V	—
System control and power management, GPIO1, GPIO2, debug, IRQ		O1V _{DD}	ON	1.8 V ± 90 mV	V	—
DUART, I ² C, DMA, QE, TDM, LPUART1, 2, 4, GPIO1, eSDHC, SAI(I ² S) 3, 4, SPDIF, FTM4, FTM8, SPI2, IRQ		D1V _{DD} DV _{DD}	ON OFF	3.3 V ± 165 mV 1.8 V ± 90 mV	V	6, 7
QSPI, SPI1, IFC, FTM5, FTM6, FTM7, I ² C, GPIO3		BV _{DD}	OFF	3.3 V ± 165mV 1.8 V ± 90mV	V	—
GPIO2, eSDHC, LPUART3, 5, 6		EV _{DD}	OFF	3.3 V ± 165 mV 1.8 V ± 90 mV	V	—
DDR DRAM I/O voltage	DDR4	G1V _{DD}	OFF	1.2V ± 60 mV	V	—
	DDR3L		OFF	1.35 V ± 67 mV		
Main power supply for internal circuitry of SerDes and pad power supply for SerDes receivers		S1V _{DD}	OFF	1.0 V ± 30 mV	V	—
Pad power supply for SerDes transmitters		X1V _{DD}	OFF	1.35 V ± 67 mV	V	—
Ethernet interface 2 and 3, Ethernet management interface 1 (EMI1), 1588, GPIO1, GPIO3, USB2, FTM2, FTM3		LV _{DD}	OFF	3.3 V ± 165 mV 2.5 V ± 125 mV 1.8 V ± 90 mV	V	1, 7
Ethernet interface 1, GPIO3, SAI(I ² S) 1, 2, FTM1		L1V _{DD}	ON	3.3 V ± 165 mV 2.5 V ± 125 mV 1.8 V ± 90 mV	V	1, 7
USB PHY Transceiver supply voltage		USB_HV _{DD}	OFF	3.3 V ± 165 mV	V	—
		USB1_SDV _{DD}	OFF	1.0 V ± 30 mV	V	—
		USB1_SXV _{DD}	OFF	1.0 V ± 30 mV	V	—
USB PHY Analog supply voltage		USB1_SPV _{DD}	OFF	1.0 V ± 30 mV	V	—
Input voltage	DDR3L and DDR4 DRAM signals	MV _{IN}	—	GND to G1V _{DD}	V	—

Table continues on the next page...

Table 3. Recommended operating conditions (continued)

Characteristic		Symbol	Power domain in deep sleep	Recommended Value	Unit	Notes
	DDR3L and DDR4 DRAM reference	D1_MV _{REF}	—	G1V _{DD} /2	V	—
	Ethernet interface 2 and 3, Ethernet management interface 1 (EMI1), 1588, GPIO1, GPIO3, USB2, FTM2, FTM3	LV _{IN}	—	GND to LV _{DD}	V	—
	Ethernet interface 1, GPIO3, SAI(I ² S), FTM1	L1V _{IN}	—	GND to L1V _{DD}	V	—
	Clocking, debug, DDRCLK supply, JTAG, RTC, IRQ	OV _{IN}	—	GND to OV _{DD}	V	—
	System control and power management, debug, GPIO1, GPIO2, IRQ	O1V _{IN}	—	GND to O1V _{DD}	V	—
	QSPI, SPI1, IFC, GPIO3, FTM5, FTM6, FTM7, I ² C	BV _{IN}	—	GND to BV _{DD}	V	—
	DUART, I ² C, DMA, TDM, QE, eSDHC, LPUART1, 2, 4, GPIO1, SAI(I ² S) 3, 4, SPDIF, FTM4, FTM8, SPI2, IRQ	DV _{IN} D1V _{IN}	—	GND to DV _{DD} GND to D1V _{DD}	V	6
	GPIO, eSDHC	EV _{IN}	—	GND to EV _{DD}	V	—
	SerDes signals	SV _{IN}	—	GND to S1V _{DD}	V	—
	USB PHY Transceiver signals	USB_HV _{IN}	—	GND to USB_HV _{DD}	V	—
Operating temperature range	Normal operation	T _A , T _J	—	T _A = 0 (min) to T _J = 105(max)	°C	—
	Extended temperature	T _A , T _J	—	T _A = -40 (min) to T _J = 105(max)	°C	—
	Secure boot fuse programming	T _A , T _J	—	T _A = 0°C (min) to T _J = 105°C (max)	°C	2

Notes:

1. RGMII is supported at 2.5 V or 1.8 V. RMII/MII are supported at 3.3 V.
2. TA_PROG_SFP must be supplied 1.8 V and the chip must operate in the specified fuse programming temperature range only during secure boot fuse programming. For all other operating conditions, TA_PROG_SFP must be tied to GND, subject to the power sequencing constraints shown in [Power sequencing](#).
3. Refer to [Core and platform supply voltage filtering](#) for additional information.
4. Supply voltage specified at the voltage sense pin. Voltage input pins should be regulated to provide specified voltage at the sense pin.

Table 3. Recommended operating conditions

Characteristic	Symbol	Power domain in deep sleep	Recommended Value	Unit	Notes
5. Operation at 1.1 V is allowable for up to 25 ms at initial power on.					
6. See the power supply column in Table 1 to determine which power supply rail is used for each interface.					
7. LV_{DD} and $L1V_{DD}$ must always be the same voltage. This also applies to DV_{DD} and $D1V_{DD}$					

This figure shows the overshoot and undershoot voltages at the interfaces of the chip.

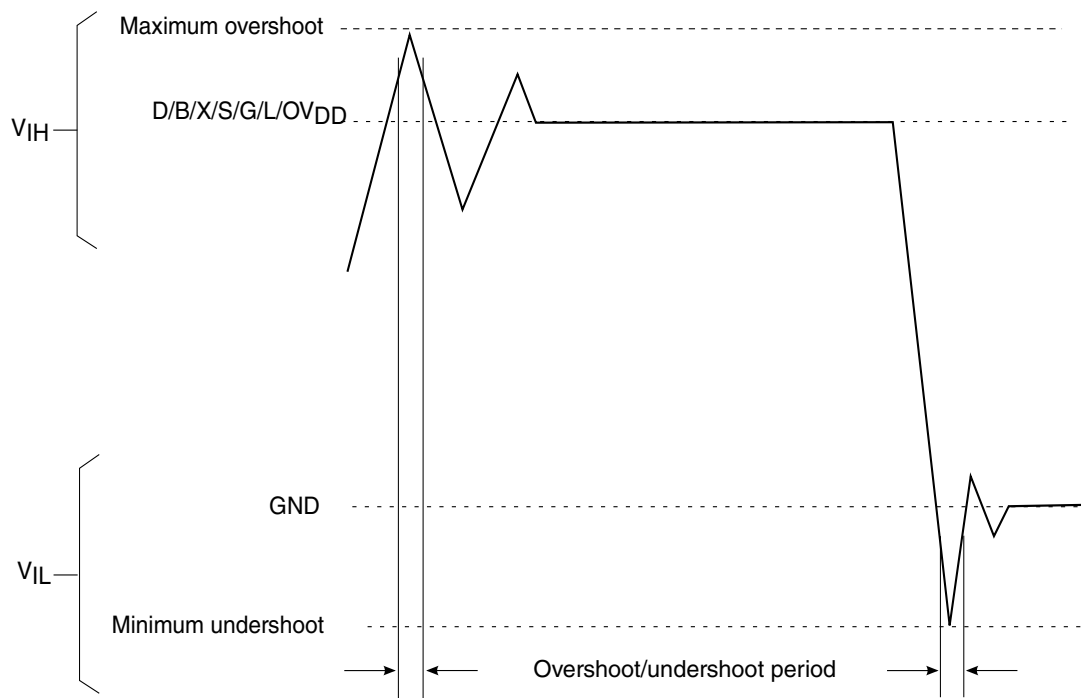
**Notes:**

The overshoot/undershoot period should be less than 10% of shortest possible toggling period of the input signal or per input signal specific protocol requirement. For GPIO input signal overshoot/undershoot period, it should be less than 10% of the SYSCLK period.

Figure 7. Overshoot/undershoot voltage for $G1V_{DD}/L1V_{DD}/O1V_{DD}/OV_{DD}/X1V_{DD}/S1V_{DD}/D1V_{DD}/DV_{DD}/BV_{DD}/LV_{DD}/EV_{DD}$

See [Table 3](#) for actual recommended core voltage. Voltage to the processor interface I/Os are provided through separate sets of supply pins and must be provided at the voltages shown in [Table 3](#). The input voltage threshold scales with respect to the associated I/O supply voltage. DV_{DD-} , OV_{DD-} , and LV_{DD-} -based receivers are simple CMOS I/O circuits and satisfy appropriate LVCMOS type specifications. The DDR SDRAM interface uses differential receivers referenced by the externally supplied Dn_MV_{REF} signal (nominally set to $G1V_{DD}/2$) as is appropriate for the SSTL_1.35/SSTL_1.2 electrical signaling standard. The DDR DQS receivers cannot be operated in single-ended fashion. The complement signal must be properly driven and cannot be grounded.

3.1.3 Output driver characteristics

This table provides information on the characteristics of the output driver strengths. Note that these values are preliminary estimates.

Table 4. Output driver capability

Driver type	Output impedance (Ω)			Supply voltage	Notes
	Min ²	Typical	Max ³		
DDR3L signal	—	18 (full-strength mode) 27 (half-strength mode)	—	G1V _{DD} = 1.35 V	1
DDR4 signal	—	18 (full-strength mode) 27 (half-strength mode)	—	G1V _{DD} = 1.2 V	1
Ethernet signals	45	—	90	L1V _{DD} /LV _{DD} = 3.3V	—
	40		90	L1V _{DD} /LV _{DD} = 2.5V	
	40		75	L1V _{DD} /LV _{DD} = 1.8V	
GPIO, system control and power management, clocking, debug, DDRCLK supply, and JTAG I/O voltage	23	—	51	OV _{DD} , O1V _{DD} = 1.8 V	—
DUART, QE, TDM, I ² C, LPUART, GPIO, eSDHC, SAI(I ² S), SPDIF, FTM	40	—	75	D1V _{DD} /DV _{DD} = 1.8V	—
	45		90	D1V _{DD} /DV _{DD} = 3.3V	
QSPI, IFC, FTM, I ² C	40	—	75	BV _{DD} = 1.8V	—
	45		90	BV _{DD} = 3.3V	
eSDHC	40	—	75	EV _{DD} = 1.8V	—
GPIO	45	—	90	EV _{DD} = 3.3V	
Note:					
1. The drive strength of the DDR4 or DDR3L interface in half-strength mode is at T _j = 105 °C and at G1V _{DD} (min).					
2. Estimated number based on best case processed device.					
3. Estimated number based on worst case processed device.					

3.2 Power sequencing

Apply the power rails in a specific sequence to ensure proper device operation. The required power-up sequence is as follows:

Table 5. Power-up sequence

Step	Procedure	Notes
1.	BV _{DD} , AV _{DD_CGA1} , AV _{DD_PLAT} , AV _{DD_D1} , O1V _{DD} , OV _{DD} , D1V _{DD} , DV _{DD} , L1V _{DD} , LV _{DD} , EV _{DD} , TH_VDD, USB_HV _{DD} . Drive PROG_SFP = GND.	1
2.	V _{DDC} , V _{DD} , S1V _{DD} , TA_BB_V _{DD} , USB1_SPV _{DD} , USB1_SDV _{DD} , USB1_SXV _{DD}	2, 3
3.	G1V _{DD} , AV _{DD_SD1_PLL1} , AV _{DD_SD1_PLL2} , X1V _{DD}	4, 5
Notes:		
1. PORESET_B should be driven, asserted, and held during this step.		
2. When deep sleep mode is used, V _{DDC} should ramp up before V _{DD} . Alternatively, V _{DD} may ramp up together with V _{DDC} provided that the relative timing between V _{DDC} and V _{DD} ramp up conforms to Figure 8 .		
3. When deep sleep is not used, it is recommended source VDD and VDDC from the same power supply.		
4. When using DDR4, AVDD_SD1_PLL1, AVDD_SD1_PLL2, X1VDD may ramp up with step 1 supplies.		
5. When using DDR3L, all supplies in step 3 above may be sourced from the same supply.		

Required sequence for exiting deep sleep mode:

Table 6. Sequence for exiting deep sleep mode

Step	Procedure	Notes
1.	USB_HV _{DD} , BV _{DD} , AV _{DD_CGA1} , AV _{DD_D1} , DV _{DD} , LV _{DD} , EV _{DD} , TH_VDD	1
2.	V _{DD} , S1V _{DD} , TA_BB_V _{DD} , USB1_SPV _{DD} , USB1_SDV _{DD} , USB1_SXV _{DD}	
3.	G1V _{DD} , AV _{DD_SD1_PLL1} , AV _{DD_SD1_PLL2} , X1V _{DD}	2, 3
Notes:		
1. PORESET_B should be driven, asserted, and held during this step.		
2. When using DDR4, AVDD_SD1_PLL1, AVDD_SD1_PLL2, X1VDD may ramp up with step 1 supplies.		
3. When using DDR3L, all supplies in step 3 above may be sourced from the same supply.		

Items on the same line have no ordering requirement with respect to one another. Items on separate lines must be ordered sequentially such that voltage rails on a previous step must reach 90% of their value before the voltage rails on the current step reach 10% of their value.

All supplies must be at their stable values within 400 ms.

Negate PORESET_B input when the required assertion/hold time has been met per the table in section [Power-on ramp rate](#).

The supplies mentioned as OFF in the "Power Domain in Deep Sleep" column of [Table 3](#) are switched ON during exit from deep sleep power management mode. These supplies should also follow the same power up sequence as mentioned above.

NOTE

- While VDD is ramping, current may be supplied from VDD through the LS1021A to G1VDD.
- EVT2_B may be unstable when PORESET_B is asserted. The signal should not be used to enable switchable power supplies during this period.
- Ramp rate requirements should be met per section [Power-on ramp rate](#).

NOTE

Only 300,000 POR cycles are permitted per lifetime of a device. Note that this value is based on design estimates and is preliminary.

This figure shows the V_{DDC} and V_{DD} ramp-up diagram.

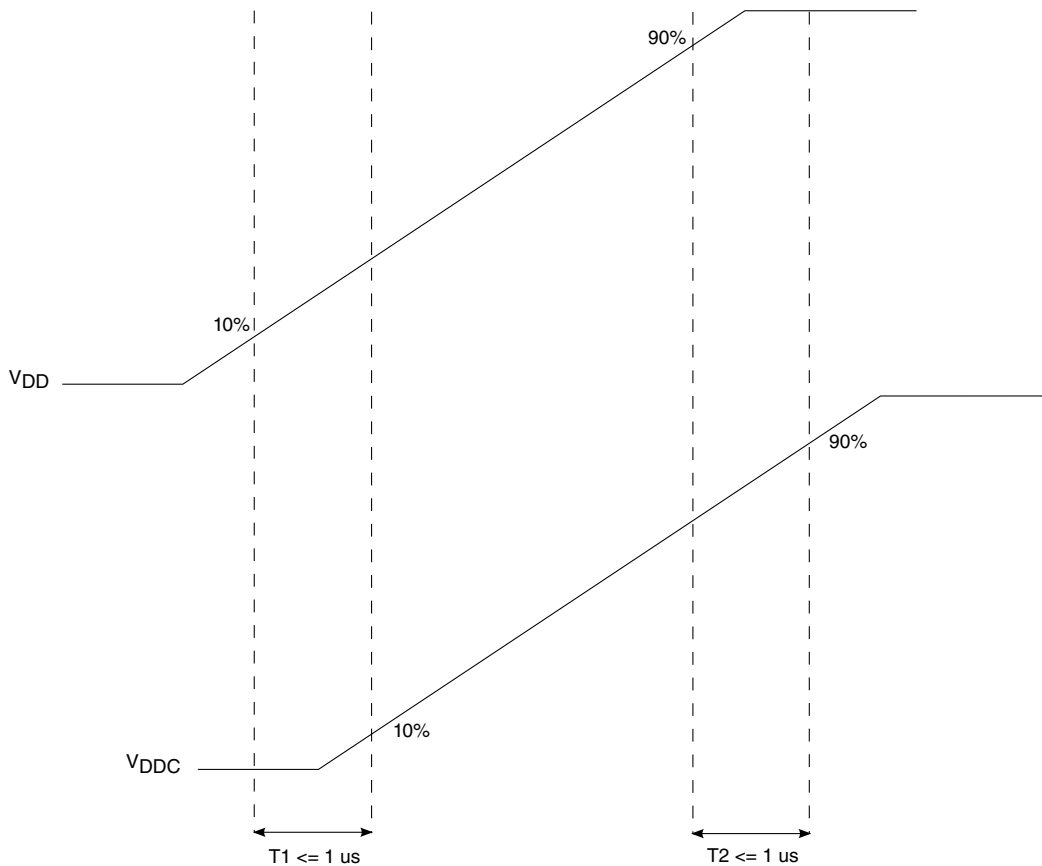

Figure 8. V_{DDC} and V_{DD} ramp-up diagram

For secure boot fuse programming, use the following steps:

1. After negation of PORESET_B, drive TA_PROG_SFP = 1.8 V after a required minimum delay per [Table 7](#).
2. After fuse programming is complete, it is required to return TA_PROG_SFP = GND before the system is power cycled (PORESET_B assertion) or powered down (V_{DD} ramp down) per the required timing specified in [Table 7](#). See [Security fuse processor](#) for additional details.
3. If using trust architecture security monitor battery backed features, prior to VDD ramping up to the 0.5V level, ensure that OVDD is ramped to recommended operational voltage and SYSCLK or DIFF_SYSCLK/DIFF_SYSCLK_B is running. These clocks should have a minimum frequency of 800Hz and a maximum frequency no greater than the supported system clock frequency for the device.

Warning

No activity other than that required for secure boot fuse programming is permitted while TA_PROG_SFP is driven to any voltage above GND, including the reading of the fuse block. The reading of the fuse block may only occur while TA_PROG_SFP = GND.

This figure shows the TA_PROG_SFP timing diagram.

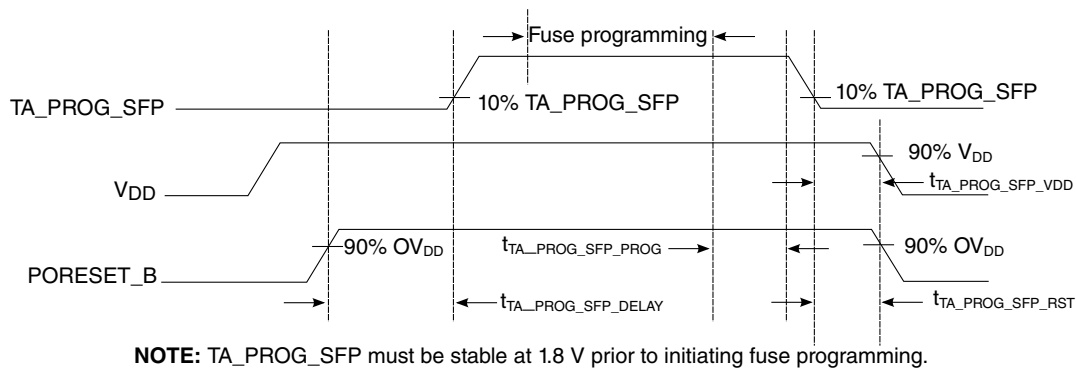

Figure 9. TA_PROG_SFP timing diagram

This table provides information on the power-down and power-up sequence parameters for TA_PROG_SFP.

Table 7. TA_PROG_SFP timing ⁵

Driver type	Min	Max	Unit	Notes
t _{TA_PROG_SFP_DELAY}	100	—	SYSClKs	1
t _{TA_PROG_SFP_PROG}	0	—	us	2
t _{TA_PROG_SFP_VDD}	0	—	us	3

Table continues on the next page...

Table 7. TA_PROG_SFP timing ⁵ (continued)

Driver type	Min	Max	Unit	Notes
t _{TA_PROG_SFP_RST}	0	—	us	4
Notes:				
1. Delay required from the deassertion of PORESET_B to driving TA_PROG_SFP ramp up. Delay measured from PORESET_B deassertion at 90% OV _{DD} to 10% TA_PROG_SFP ramp up.				
2. Delay required from fuse programming completion to TA_PROG_SFP ramp down start. Fuse programming must complete while TA_PROG_SFP is stable at 1.8 V. No activity other than that required for secure boot fuse programming is permitted while TA_PROG_SFP is driven to any voltage above GND, including the reading of the fuse block. The reading of the fuse block may only occur while TA_PROG_SFP = GND. After fuse programming is complete, it is required to return TA_PROG_SFP = GND.				
3. Delay required from TA_PROG_SFP ramp-down complete to V _{DD} ramp-down start. TA_PROG_SFP must be grounded to minimum 10% TA_PROG_SFP before V _{DD} reaches 90% V _{DD} .				
4. Delay required from TA_PROG_SFP ramp-down complete to PORESET_B assertion. TA_PROG_SFP must be grounded to minimum 10% TA_PROG_SFP before PORESET_B assertion reaches 90% OV _{DD} .				
5. Only two secure boot fuse programming events are permitted per lifetime of a device.				

3.3 Power-down requirements

The power-down cycle must complete such that power supply values are below 0.4 V before a new power-up cycle can be started.

If performing secure boot fuse programming per the requirements in [Power sequencing](#), it is required that TA_PROG_SFP = GND before the system is power cycled (PORESET_B assertion) or powered down (V_{DD} ramp down) per the required timing specified in [Power sequencing](#).

3.4 Power characteristics

This table provides the power dissipations of the V_{DD} and V_{DDC} supply for various operating platform clock frequencies versus the core and DDR clock frequencies.

Table 8. Core power dissipation

Power mode	Core freq (MHz)	Plat freq (MHz)	DDR data rate (MT/s)	V _{DDC} , V _{DD} , S1V _{DD} , TA_BB_V _D _D (V)	Junction temp. (°C)	Total core and platform power (W) ¹	Power (W)				Notes
							V _{DD}	V _{DDC}	S1V _{DD}	TA_BB_V _{DD}	
Typical	1000	300	1600	1.0	65	2.09	1.59	0.20	0.29	0.01	2, 3

Table continues on the next page...

Table 8. Core power dissipation (continued)

Power mode	Core freq (MHz)	Plat freq (MHz)	DDR data rate (MT/s)	V _{DDC} , V _{DD} , S1V _{DD} , TA_BB_V _D _D (V)	Junction temp. (°C)	Total core and platform power (W) ¹	Power (W)				Notes
							V _{DD}	V _{DDC}	S1V _{DD}	TA_BB_V _{DD}	
Thermal					105	3.68	2.94	0.40	0.32	0.02	6, 7
Maximum						3.82	3.06	0.41	0.32	0.02	4, 5
Typical	800	300	1300	1.0	65	1.97	1.49	0.18	0.29	0.01	2, 3
Thermal					105	3.56	2.84	0.38	0.32	0.02	6, 7
Maximum						3.68	2.95	0.39	0.32	0.02	4, 5

Notes:

1. Combined power of V_{DD}, V_{DDC}, S1V_{DD}, and TA_BB_V_{DD} with DDR controller and all SerDes banks active. Does not include I/O power.
2. Typical power assumes Dhrystone running with activity factor of 80% (on all cores) and executing DMA on the platform with 100% activity factor.
3. Typical power based on nominal processed device.
4. Maximum power assumes multicore Dhrystone running with a 100% activity factor and executing DMA on the platform with a 115% activity factor.
5. Maximum power is provided for power supply design sizing.
6. Thermal power assumes multicore Dhrystone running with an 80% activity factor and executing DMA on the platform with a 115% activity factor.
7. Thermal and maximum power are based on worst-case processed device.

3.4.1 Low power mode saving estimation

Refer to this table for low power mode savings.

Table 9. Low power mode savings, 1.0 V, 65C^{1, 2, 3}

Mode	Core Frequency = 800MHz	Core Frequency = 1.0GHz	Units	Notes
PW15	0.04	0.05	Watts	4
PCL10	0.06	0.07	Watts	
LMP20	0.33	0.39	Watts	5

Notes:

1. Power for VDD only
2. Typical power assumes Dhrystone running with activity factor of 80%
3. Typical power based on nominal process distribution for this device.
4. PW15 power savings with 1 core. Maximum savings would be N times, where N is the number of used cores.

Table 9. Low power mode savings, 1.0 V, 65C^{1, 2, 3}

5. LPM20 has all platform clocks disabled.

3.4.2 LPM35 Deep sleep power dissipation, 1.0 V, 35C¹

Power (W)			Total core and platform power (W)
V _{DD}	V _{DDC}	S1V _{DD}	
-	0.15	-	0.15

Notes:

- V_{DD} and S1V_{DD} are switched off during deep sleep mode.

3.5 I/O DC power supply recommendation

The following table provides the estimated I/O power numbers for each block. The numbers listed below are based on design estimates only.

Table 10. Estimated I/O power supply values values

Interface	I/O Power supply		Parameter	Typical (W)	Max (W) ⁸	Notes
System control and power management, clocking, debug, DDRCLK supply, GPIO, and JTAG I/O voltage	LVC MOS	OVDD/O1VDD 1.8V		0.015	0.021	1,3,4,6
QSPI	LVC MOS	BVDD 1.8V		0.038	0.038	1,3,4,6
	LVC MOS	BVDD 3.3V		0.101	0.101	1,3,4,6
SPI	LVC MOS	BVDD 1.8V		0.012	0.015	1,3,4,6
	LVC MOS	BVDD 3.3V		0.026	0.032	1,3,4,6
IFC	LVC MOS	BVDD 1.8V		0.094	0.097	1,3,4,6
	LVC MOS	BVDD 3.3V		0.245	0.250	1,3,4,6
Ethernet interface	LVC MOS	LVDD/L1VDD 1.8V		0.103	0.104	1,3,4,6
	LVC MOS	LVDD/L1VDD 2.5V		0.169	0.171	1,3,4,6
	LVC MOS	LVDD/L1VDD 3.3V		0.275	0.278	1,3,4,6
1588	LVC MOS	LVDD 1.8V		0.012	0.014	1,3,4,6
	LVC MOS	LVDD 2.5V		0.019	0.022	1,3,4,6

Table continues on the next page...

Table 10. Estimated I/O power supply values values (continued)

Interface	I/O Power supply		Parameter	Typical (W)	Max (W) ⁸	Notes
	LVC MOS	LVDD 3.3V		0.030	0.034	1,3,4,6
GPIO	LVC MOS	LVDD/L1VDD/ DVDD/EVDD 1.8V		0.009	0.013	1,3,4,6
	LVC MOS	LVDD/L1VDD 2.5V		0.013	0.018	1,3,4,6
	LVC MOS	LVDD/L1VDD/ DVDD/EVDD 3.3V		0.019	0.026	1,3,4,6
USB2	LVC MOS	LVDD 1.8V		0.015	0.018	1,3,4,6
	LVC MOS	LVDD 2.5V		0.022	0.026	1,3,4,6
	LVC MOS	LVDD 3.3V		0.033	0.040	1,3,4,6
FlexTimer	LVC MOS	LVDD/L1VDD/ DVDD 1.8V		0.019	0.026	1,3,4,6
	LVC MOS	LVDD/L1VDD/ DVDD 2.5V		0.026	0.036	1,3,4,6
	LVC MOS	LVDD/L1VDD/ DVDD 3.3V		0.038	0.052	1,3,4,6
Ethernet Management Interface	LVC MOS	LVDD 1.8V		0.002	0.003	1,3,4,6
	LVC MOS	LVDD 2.5V		0.003	0.004	1,3,4,6
	LVC MOS	LVDD 3.3V		0.005	0.006	1,3,4,6
SAI(I2S)	LVC MOS	L1VDD/DVDD 1.8V		0.016	0.019	1,3,4,6
	LVC MOS	L1VDD 2.5V		0.024	0.029	1,3,4,6
	LVC MOS	L1VDD/DVDD 3.3V		0.037	0.044	1,3,4,6
DUART	LVC MOS	DVDD 1.8V		0.004	0.005	1,3,4,6
	LVC MOS	DVDD 3.3V		0.008	0.010	1,3,4,6
I2C	LVC MOS	DVDD/BVDD 1.8V		0.003	0.004	1,3,4,6
	LVC MOS	DVDD/BVDD 3.3V		0.006	0.009	1,3,4,6
QE	LVC MOS	DVDD 1.8V		0.014	0.018	1,3,4,6
	LVC MOS	DVDD 3.3V		0.033	0.040	1,3,4,6

Table continues on the next page...

Table 10. Estimated I/O power supply values values (continued)

Interface	I/O Power supply		Parameter	Typical (W)	Max (W) ⁸	Notes
LPUART	LVC MOS	DVDD 1.8V		0.009	0.012	1,3,4,6
	LVC MOS	DVDD 3.3V		0.019	0.024	1,3,4,6
SPDIF	LVC MOS	DVDD 1.8V		0.006	0.007	1,3,4,6
	LVC MOS	DVDD 3.3V		0.015	0.017	1,3,4,6
eSDHC	LVC MOS	EVDD/DVDD 1.8V		0.026	0.027	1,3,4,6
	LVC MOS	EVDD/DVDD 3.3V		0.071	0.075	1,3,4,6
DDR3L	DDR I/O	GVDD 1.35V	1000 MT/s	0.350	0.684	1,2,5,6
	DDR I/O	GVDD 1.35V	1300 MT/s	0.393	0.772	1,2,5,6
	DDR I/O	GVDD 1.35V	1600 MT/s	0.448	0.883	1,2,5,6
DDR4	DDR I/O	GVDD 1.2V	1300 MT/s	0.311	0.619	1,2,5,6
	DDR I/O	GVDD 1.2V	1600 MT/s	0.354	0.698	1,2,5,6
USB PHY	USB_PHY	USB1_SXVDD 1.0V		0.019	0.026	1,6
	USB_PHY	USB1_SPVDD 1.0V		0.032	0.044	1,6
	USB_PHY	USB_SDVDD 1.0V		0.006	0.011	1,6
	USB_PHY	USB_HVDD 3.3V		0.125	0.146	1,6
PLL	PLL core and system	AVDD_CGA1 AVDD_PLAT 1.8V		0.02	0.02	3,6
	PLL DDR	AVDD_D1 1.8V		0.02	0.02	3,6
	PLL LYNX	AVDD_D1_PLL 1.35V		0.03	0.04	3,6
SGMII	SerDes 1.35V	X1VDD	(x1)1.25G-baud	0.076	0.084	1,6,7
SATA	SerDes 1.35V	X1VDD	(x1)3.0G-baud	0.076	0.083	1,6,7
PEX	SerDes 1.35V	X1VDD	(x1)5.0G-baud	0.082	0.090	1,6,7
	SerDes 1.35V	X1VDD	(x2)5.0G-baud	0.115	0.122	1,6,7
	SerDes 1.35V	X1VDD	(x4)5.0G-baud	0.179	0.187	1,6,7

Notes:

1. The maximum values are dependent on actual use case such as what application, external components used, environmental conditions such as temperature voltage and frequency. This is not intended to be the maximum guaranteed power. Expect different results depending on the use case. The maximum values are estimated and they are based on simulations at 105 °C junction temperature.

2. Typical DDR power numbers are based on one 2-rank DIMM with 40% utilization.

3. Assuming 15pF total capacitance load.

Table 10. Estimated I/O power supply values

Interface	I/O Power supply	Parameter	Typical (W)	Max (W) ⁸	Notes
<p>4. GPIOs are supported on 1.8 V, 2.5 V, and 3.3 V rails as specified in the hardware specification.</p> <p>5. Maximum DDR power numbers are based on one 2-rank DIMM with 100% utilization.</p> <p>6. The typical values are estimates and based on simulations at nominal recommended voltage for the IO power supply and assuming at 65° C junction temperature.</p> <p>7. The total power numbers of X1VDD is dependent on customer application use case. This table lists all the SerDes configurations possible for the device. To get the X1VDD power numbers, the user should add the combined lanes to match to the total SerDes Lanes used, not simply multiply the power numbers by the number of lanes.</p> <p>8. The maximum values are dependent on actual use case such as what application, external components used, environmental conditions such as temperature voltage and frequency. This is not intended to be the maximum guaranteed power. Expect different results depending on the use case. The maximum values are estimated and they are based on simulations at 105°C junction temperature.</p>					

3.6 Power-on ramp rate

This section describes the AC electrical specifications for the power-on ramp rate requirements. Controlling the maximum power-on ramp rate is required to avoid excess in-rush current.

This table provides the power supply ramp rate specifications.

Table 11. Power supply ramp rate

Parameter	Min	Max	Unit	Notes
Required ramp rate for all voltage supplies (except for TA_PROG_SFP and USB_HVDD)	—	25	V/ms	1, 2
TA_PROG_SFP	—	25	V/ms	1, 2
USB_HVDD	—	26.7	V/ms	1, 2
Notes:				
1. Ramp rate is specified as a linear ramp from 10% to 90%. If non-linear (for example, exponential), the maximum rate of change from 200 mV to 500 mV is the most critical as this range might falsely trigger the ESD circuitry.				
2. Over full recommended operating temperature range. See Table 3 .				

3.7 Input clocks

3.7.1 System clock (SYSCLK)

This section describes the system clock DC electrical characteristics and AC timing specifications.

3.7.1.1 SYSCLK DC electrical characteristics

This table provides the SYSCLK DC characteristics.

Table 12. SYSCLK DC electrical characteristics³

Parameter	Symbol	Min	Typical	Max	Unit	Notes
Input high voltage	V_{IH}	$0.7 \times O1V_{DD}$	—	—	V	1
Input low voltage	V_{IL}	—	—	$0.2 \times O1V_{DD}$	V	1
Input capacitance	C_{IN}	—	7	12	pF	—
Input current ($O1V_{IN} = 0$ V or $O1V_{IN} = O1V_{DD}$)	I_{IN}	—	—	± 50	μ A	2

Notes:

1. The min V_{IL} and max V_{IH} values are based on the respective min and max $O1V_{IN}$ values found in [Table 3](#).
2. The symbol $O1V_{IN}$, in this case, represents the $O1V_{IN}$ symbol referenced in [Table 3](#).
3. At recommended operating conditions with $O1V_{DD} = 1.8$ V. See [Table 3](#).

3.7.1.2 SYSCLK AC timing specifications

This table provides the SYSCLK AC timing specifications.

Table 13. SYSCLK AC timing specifications^{1, 5}

Parameter/condition	Symbol	Min	Typ	Max	Unit	Notes
SYSCLK frequency	f_{SYSCLK}	64.0	—	133.3	MHz	2
SYSCLK cycle time	t_{SYSCLK}	7.5	—	15.6	ns	1, 2
SYSCLK duty cycle	t_{KHK}/t_{SYSCLK}	40	—	60	%	2
SYSCLK slew rate	—	1	—	4	V/ns	3
SYSCLK peak period jitter	—	—	—	± 150	ps	—
SYSCLK jitter phase noise at -56 dBc	—	—	—	500	kHz	4
AC Input Swing Limits at 1.8 V $O1V_{DD}$	ΔV_{AC}	1.08	—	1.8	V	—

Notes:

1. **Caution:** The relevant clock ratio settings must be chosen such that the resulting SYSCLK frequencies do not exceed their respective maximum or minimum operating frequencies.
2. Measured at the rising edge and/or the falling edge at $O1V_{DD}/2$.
3. Slew rate as measured from $0.35 \times O1V_{DD}$ to $0.65 \times O1V_{DD}$.
4. Phase noise is calculated as FFT of TIE jitter.
5. At recommended operating conditions with $O1V_{DD} = 1.8$ V. See [Table 3](#).

3.7.2 Spread-spectrum sources

Spread-spectrum clock sources are an increasingly popular way to control electromagnetic interference emissions (EMI) by spreading the emitted noise to a wider spectrum and reducing the peak noise magnitude in order to meet industry and government requirements. These clock sources intentionally add long-term jitter to diffuse the EMI spectral content.

The jitter specification given in this table considers short-term (cycle-to-cycle) jitter only. The clock generator's cycle-to-cycle output jitter should meet the chip's input cycle-to-cycle jitter requirement.

Frequency modulation and spread are separate concerns; the chip is compatible with spread-spectrum sources if the recommendations listed in this table are observed.

Table 14. Spread-spectrum clock source recommendations³

Parameter	Min	Max	Unit	Notes
Frequency modulation	—	60	kHz	—
Frequency spread	—	1.0	%	1, 2

Notes:

1. SYSCLK frequencies that result from frequency spreading and the resulting core frequency must meet the minimum and maximum specifications given in [Table 13](#).
2. Maximum spread-spectrum frequency may not result in exceeding any maximum operating frequency of the device.
3. At recommended operating conditions with O1VDD = 1.8 V. See [Table 3](#).

CAUTION

The processor's minimum and maximum SYSCLK and core/platform/DDR frequencies must not be exceeded, regardless of the type of clock source. Therefore, systems in which the processor is operated at its maximum rated core/platform/DDR frequency should use only down-spreading to avoid violating the stated limits.

3.7.3 Real-time clock timing (RTC)

This table provides the real-time clock recommendations.

Table 15. Real-time clock recommendations

Parameter	Min	Typical	Max	Unit	Notes
RTC	32.000 -100 ppm	32.000	32.768 +100 ppm	kHz	1

3.7.4 Gigabit Ethernet reference clock timing

This table provides the Ethernet gigabit reference clock DC electrical characteristics with $L1V_{DD}/LV_{DD} = 1.8\text{ V}$.

Table 16. ECn_GTX_CLK125 DC electrical characteristics (L1VDD/LVDD = 1.8 V)¹

Parameter	Symbol	Min	Typical	Max	Unit	Notes
Input high voltage	V_{IH}	$0.7 \times L1V_{DD}$	—	—	V	2
Input low voltage	V_{IL}	—	—	$0.2 \times L1V_{DD}$	V	2
Input capacitance	C_{IN}	—	—	6	pF	—
Input current ($V_{IN} = 0\text{ V}$ or $V_{IN} = L1V_{DD}/LV_{DD}$)	I_{IN}	—	—	± 50	μA	3

Notes:

1. For recommended operating conditions, see [Table 3](#).
2. The min V_{IL} and max V_{IH} values are based on the respective min and max V_{IN} values found in [Table 3](#).
3. The symbol V_{IN} , in this case, represents the $L1V_{IN}/LV_{IN}$ symbol referenced in [Table 3](#).

This table provides the Ethernet gigabit reference clock DC electrical characteristics with $L1V_{DD}/LV_{DD} = 2.5\text{ V}$.

Table 17. ECn_GTX_CLK125 DC electrical characteristics (L1VDD/LVDD = 2.5 V)¹

Parameter	Symbol	Min	Typical	Max	Unit	Notes
Input high voltage	V_{IH}	$0.7 \times L1V_{DD}$	—	—	V	2
Input low voltage	V_{IL}	—	—	$0.2 \times L1V_{DD}$	V	2
Input capacitance	C_{IN}	—	—	6	pF	—
Input current ($V_{IN} = 0\text{ V}$ or $V_{IN} = L1V_{DD}/LV_{DD}$)	I_{IN}	—	—	± 50	μA	3

Notes:

1. For recommended operating conditions, see [Table 3](#).
2. The min V_{IL} and max V_{IH} values are based on the respective min and max V_{IN} values found in [Table 3](#).
3. The symbol V_{IN} , in this case, represents the $L1V_{IN}/LV_{IN}$ symbol referenced in [Table 3](#).

This table provides the Ethernet gigabit reference clock AC timing specifications.

Table 18. ECn_GTX_CLK125 AC timing specifications^{1, 4}

Parameter/Condition	Symbol	Min	Typical	Max	Unit	Notes
ECn_GTX_CLK125 frequency	t_{G125}	125-100ppm	125	125+100ppm	MHz	—
ECn_GTX_CLK125 cycle time	t_{G125}	—	8	—	ns	—

Table continues on the next page...

Table 18. EC_n_GTX_CLK125 AC timing specifications^{1, 4} (continued)

Parameter/Condition	Symbol	Min	Typical	Max	Unit	Notes
EC _n _GTX_CLK125 rise and fall time L1/LV _{DD} = 1.8 V L1/LV _{DD} = 2.5 V	t _{G125R} /t _{G125F}	—	—	0.54 0.75	ns	2
EC _n _GTX_CLK125 duty cycle 1000Base-T for RGMII	t _{G125H} /t _{G125}	40	—	60	%	3
EC _n _GTX_CLK125 jitter	—	—	—	± 150	ps	3
Notes:						
1. At recommended operating conditions with L1/LV _{DD} = 1.8 V ± 90mV / 2.5 V ± 125 mV. See Table 3 .						
2. Rise and fall times for EC _n _GTX_CLK125 are measured from 0.5 and 2.0 V for L1/LV _{DD} = 2.5 V.						
3. EC _n _GTX_CLK125 is used to generate the GTX clock for the Ethernet transmitter with 2% degradation. The EC _n _GTX_CLK125 duty cycle can be loosened from 47% to 53%, as long as the PHY device can tolerate the duty cycle generated by the GTX_CLK. See RGMII AC timing specifications for duty cycle for the 10Base-T and 100Base-T reference clocks.						
4. The frequency of EC _n _RX_CLK (input) should not exceed the frequency of EC_GTX_CLK125/EC _n _TX_CLK (input) by more than 300 ppm.						

3.7.5 DDR clock (DDRCLK)

This section provides the DDRCLK DC electrical characteristics and AC timing specifications.

3.7.5.1 DDRCLK DC electrical characteristics

This table provides the DDRCLK DC electrical characteristics.

Table 19. DDRCLK DC electrical characteristics³

Parameter	Symbol	Min	Typical	Max	Unit	Notes
Input high voltage	V _{IH}	0.7 x OV _{DD}	—	—	V	1
Input low voltage	V _{IL}	—	—	0.2 x OV _{DD}	V	1
Input capacitance	C _{IN}	—	7	12	pF	—
Input current (OV _{IN} = 0 V or OV _{IN} = OV _{DD})	I _{IN}	—	—	± 100	μA	2
Notes:						
1. The min V _{IL} and max V _{IH} values are based on the respective min and max OV _{IN} values found in Table 3 .						
2. The symbol OV _{IN} , in this case, represents the OV _{IN} symbol referenced in Table 3 .						
3. At recommended operating conditions with OV _{DD} = 1.8 V. See Table 3 .						

3.7.5.2 DDRCLK AC timing specifications

This table provides the DDRCLK AC timing specifications.

Table 20. DDRCLK AC timing specifications⁵

Parameter/Condition	Symbol	Min	Typ	Max	Unit	Notes
DDRCLK frequency	f_{DDRCLK}	64.0	—	133.3	MHz	1, 2
DDRCLK cycle time	t_{DDRCLK}	7.5	—	15.6	ns	1, 2
DDRCLK duty cycle	t_{KHK}/t_{DDRCLK}	40	—	60	%	2
DDRCLK slew rate	—	1	—	4	V/ns	3
DDRCLK peak period jitter	—	—	—	± 150	ps	—
DDRCLK jitter phase noise at -56 dBc	—	—	—	500	kHz	4
AC input swing limits at 1.8 V OV_{DD}	ΔV_{AC}	1.08	—	1.8	V	—

Notes:

- Caution:** The relevant clock ratio settings must be chosen such that the resulting DDRCLK frequencies do not exceed their respective maximum or minimum operating frequencies.
- Measured at the rising edge and/or the falling edge at $OV_{DD}/2$.
- Slew rate as measured from $0.35 \times OV_{DD}$ to $0.65 \times OV_{DD}$.
- Phase noise is calculated as FFT of TIE jitter.
- At recommended operating conditions with $OV_{DD} = 1.8V$. See [Table 3](#).

3.7.6 Differential system clock (DIFF_SYSCLK/DIFF_SYSCLK_B) timing specifications

Single-source clocking mode requires the single onboard oscillator to provide reference clock input to the differential system clock pair, DIFF_SYSCLK/DIFF_SYSCLK_B. This differential clock pair input provides clocking to the core, platform, DDR, and USB PLLs. The following figure shows a receiver reference diagram of the differential system clock.

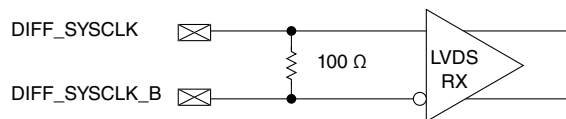

Figure 10. LVDS receiver

This section provides the differential system clock DC electrical characteristics and AC timing specifications.

3.7.6.1 Differential system clock DC electrical characteristics

The differential system clock receiver's core power supply voltage requirements ($O1V_{DD}$) are specified in [Recommended operating conditions](#).

The differential system clock can also be single-ended. For this, DIFF_SYSCLK_B should be connected to $O1V_{DD}/2$.

Table 21. Differential system clock DC electrical characteristics

Parameter	Symbol	Min	Typical	Max	Unit	Notes
Input differential voltage swing	V_{id}	100	—	600	mV	3
Input common mode voltage	V_{icm}	50	—	1570	mV	—
Power supply current	I_{cc}	—	—	5	mA	—
Input capacitance	C_{in}	—	4	—	pF	2

Note:

- At recommended operation conditions with $O1V_{DD}=1.8V$.
- The die capacitance may cause reflection of the clock signal through the package back to the pin. This should not affect the signal quality seen by internal PLL. Recommend verifying signal quality using IBIS simulations.
- Input differential voltage swing (V_{id}) specified is equal to $IV_{DIFF_SYSCLK_P} - V_{DIFF_SYSCLK_NI}$

3.7.6.2 Differential system clock AC timing specifications

The DIFF_SYSCLK/DIFF_SYSCLK_B input pair supports an input clock frequency of 100 MHz.

Spread-spectrum clocking is not supported on differential system clock pair input.

Table 22. Differential system clock AC electrical characteristics^{2, 3}

Parameter	Symbol	Min	Typical	Max	Unit	Notes
DIFF_SYSCLK/ DIFF_SYSCLK_ B frequency range	t_{DIFF_SYSCLK}	—	100	—	MHz	—
DIFF_SYSCLK/ DIFF_SYSCLK_ B frequency tolerance	t_{DIFF_TOL}	-300	—	-300	ppm	—
Duty cycle	t_{DIFF_DUTY}	40	50	60	%	—
Clock period jitter (peak to peak)	t_{DIFF_TJ}	—	—	100	ps	2
Slew rate	t_{DIFF_slew}	0.5	—	4	V/ns	—

Table continues on the next page...

Table 22. Differential system clock AC electrical characteristics^{2, 3} (continued)

Parameter	Symbol	Min	Typical	Max	Unit	Notes
Notes:						
1. At recommended operating conditions with $O1V_{DD}=1.8$ V.						
2. This is evaluated with supply noise profile at $\pm 5\%$ sine wave.						
3. The 100 MHz reference frequency is needed if USB is used. The reference clock to USB PHY is selectable between SYSCLK or DIFF_SYSCLK/DIF_SYSCLK_B. The selected clock must meet the clock specifications for USB.						

3.7.7 Other input clocks

A description of the overall clocking of this device is available in the chip reference manual in the form of a clock subsystem block diagram. For information about the input clock requirements of functional modules sourced external of the chip, such as SerDes, Ethernet management, eSDHC, and IFC, see the specific interface section.

3.8 RESET initialization

This table provides the AC timing specifications for the RESET initialization timing.

Table 23. RESET initialization timing specifications

Parameter/Condition	Min	Max	Unit	Notes
Required assertion time of PORESET_B	1	—	ms	1
Required input assertion time of HRESET_B	32	—	SYSCLKs	2, 3
Maximum rise/fall time of HRESET_B	—	10	SYSCLKs	4, 5
Maximum rise/fall time of PORESET_B	—	1	SYSCLKs	4, 6
PLL input setup time with stable SYSCLK before HRESET_B negation	100	—	μ s	—
Input setup time for POR configs with respect to negation of PORESET_B	4	—	SYSCLKs	2
Input hold time for all POR configs with respect to negation of PORESET_B	2	—	SYSCLKs	2
Maximum valid-to-high impedance time for actively driven POR configs with respect to negation of PORESET_B	—	5	SYSCLKs	2
Notes:				
1. PORESET_B must be driven asserted before the core and platform power supplies are powered up.				
2. SYSCLK is the primary clock input for the chip.				
3. The device asserts HRESET_B as an output when PORESET_B is asserted to initiate the power-on reset process. The device releases HRESET_B sometime after PORESET_B is deasserted. The exact sequencing of HRESET_B deassertion is documented in the reference manual's "Power-on Reset Sequence" section.				

Table 23. RESET initialization timing specifications

Parameter/Condition	Min	Max	Unit	Notes
4. The system/board must be designed to ensure the input requirement to the device is achieved. Proper device operation is guaranteed for inputs meeting this requirement by design, simulation, characterization, or functional testing.				
5. For HRESET_B the rise/fall time should not exceed 10 SYSCLKs. Rise time refers to signal transitions from 20% to 70% of O1VDD. Fall time refers to transitions from 70% to 20% of O1VDD.				
6. For PORESET_B the rise/fall time should not exceed 1 SYSCLK. Rise time refers to signal transitions from 20% to 70% of O1VDD. Fall time refers to transitions from 70% to 20% of O1VDD.				

This table provides the phase-locked loop (PLL) lock times.

Table 24. PLL lock times

Parameter/Condition	Min	Max	Unit	Notes
PLL lock times (Core, platform, DDR only)	—	100	μs	—

3.9 DDR3L and DDR4 SDRAM controller

This section describes the DC and AC electrical specifications for the DDR3L and DDR4 SDRAM controller interface. Note that the required $G1V_{DD}(\text{typ})$ voltage is 1.35 V when interfacing to DDR3L SDRAM, and the required $G1V_{DD}(\text{typ})$ voltage is 1.2 V when interfacing to DDR4 SDRAM.

3.9.1 DDR3L and DDR4 SDRAM interface DC electrical characteristics

This table provides the recommended operating conditions for the DDR SDRAM controller when interfacing to DDR3L SDRAM.

Table 25. DDR3L SDRAM interface DC electrical characteristics ($G1V_{DD} = 1.35 \text{ V}$)^{1, 8}

Parameter	Symbol	Min	Max	Unit	Note
I/O reference voltage	Dn_MV_{REF}	$0.49 \times G1V_{DD}$	$0.51 \times G1V_{DD}$	V	2, 3, 4
Input high voltage	V_{IH}	$Dn_MV_{REF} + 0.090$	$G1V_{DD}$	V	5
Input low voltage	V_{IL}	GND	$Dn_MV_{REF} - 0.090$	V	5
I/O leakage current	I_{OZ}	-165	165	μA	6

Notes:

1. $G1V_{DD}$ is expected to be within 50 mV of the DRAM's voltage supply at all times. The DRAM's and memory controller's voltage supply may or may not be from the same source.

Electrical characteristics

Table 25. DDR3L SDRAM interface DC electrical characteristics ($G1V_{DD} = 1.35\text{ V}$)^{1, 8}

Parameter	Symbol	Min	Max	Unit	Note
<p>2. Dn_MV_{REF} is expected to be equal to $0.5 \times G1V_{DD}$ and to track $G1V_{DD}$ DC variations as measured at the receiver. Peak-to-peak noise on Dn_MV_{REF} may not exceed the Dn_MV_{REF} DC level by more than $\pm 1\%$ of $G1V_{DD}$ (that is, $\pm 13.5\text{ mV}$).</p> <p>3. V_{TT} is not applied directly to the device. It is the supply to which far-end signal termination is made, and it is expected to be equal to Dn_MV_{REF} with a min value of $Dn_MV_{REF} - 0.04$ and a max value of $Dn_MV_{REF} + 0.04$. V_{TT} should track variations in the DC level of Dn_MV_{REF}.</p> <p>4. The voltage regulator for Dn_MV_{REF} must meet the specifications stated in Table 27.</p> <p>5. Input capacitance load for DQ, DQS, and DQS_B are available in the IBIS models.</p> <p>6. Output leakage is measured with all outputs disabled ($0\text{ V} \leq V_{OUT} \leq G1V_{DD}$).</p> <p>7. Refer to the IBIS model for the complete output IV curve characteristics.</p> <p>8. For recommended operating conditions, see Table 3.</p>					

This table provides the recommended operating conditions for the DDR SDRAM controller when interfacing to DDR4 SDRAM.

Table 26. DDR4 SDRAM interface DC electrical characteristics ($G1V_{DD} = 1.2\text{ V}$)^{1, 5}

Parameter	Symbol	Min	Max	Unit	Note
Input high voltage	V_{IH}	$0.7 \times GV_{DD} + 0.175$	—	V	2, 7
Input low voltage	V_{IL}	—	$0.7 \times GV_{DD} + 0.175$	V	2, 7
I/O leakage current	I_{OZ}	-165	165	μA	3
<p>Notes:</p> <p>1. $G1V_{DD}$ is expected to be within 60 mV of the DRAM's voltage supply at all times. The DRAM's and memory controller's voltage supply may or may not be from the same source.</p> <p>2. Input capacitance load for MDQ, MDQS, and MDQS_B are available in the IBIS models.</p> <p>3. Output leakage is measured with all outputs disabled ($0\text{ V} \leq V_{OUT} \leq G1V_{DD}$).</p> <p>4. Refer to the IBIS model for the complete output IV curve characteristics.</p> <p>5. For recommended operating conditions, see Table 3.</p> <p>6. V_{TT} and V_{REFCA} are applied directly to the DRAM device. Both V_{TT} and V_{REFCA} voltages must track $G1V_{DD}/2$.</p> <p>7. Internal Vref for data bus must be set to $0.7 \times G1V_{DD}$.</p>					

This table provides the current draw characteristics for Dn_MV_{REF} .

Table 27. Current draw characteristics for Dn_MV_{REF} ¹

Parameter	Symbol	Min	Max	Unit	Notes
Current draw for DDR3L SDRAM for Dn_MV_{REF}	I_{Dn_MVREF}	—	500	μA	—
<p>Note:</p> <p>1. For recommended operating conditions, see Table 3.</p>					

3.9.2 DDR3L and DDR4 SDRAM interface AC timing specifications

This section provides the AC timing specifications for the DDR SDRAM controller interface. The DDR controller supports DDR3L and DDR4 memories. Note that the required $G1V_{DD}(\text{typ})$ voltage is 1.35 V or 1.2 V when interfacing to DDR3L or DDR4 SDRAM respectively.

3.9.2.1 DDR3L and DDR4 SDRAM interface input AC timing specifications

This table provides the input AC timing specifications for the DDR controller when interfacing to DDR4 SDRAM.

Table 28. DDR4 SDRAM interface input AC timing specifications ($GV_{DD} = 1.2 \text{ V} \pm 5\%$)⁴

		Symbol	Min	Max	Unit	Notes
AC input low voltage	$\leq 1600\text{MT/s}$ data rate	V_{ILAC}	—	$0.7 \times GV_{DD} + 0.175$	V	—
AC input high voltage	$\leq 1600\text{MT/s}$ data rate	V_{IHAC}	$0.7 \times GV_{DD} + 0.175$	—	V	—

This table provides the input AC timing specifications for the DDR controller when interfacing to DDR3L and DDR4 SDRAM.

Table 29. DDR3L and DDR4 SDRAM interface input AC timing specifications³

Parameter	Symbol	Min	Max	Unit	Notes	
Controller skew for MDQS-MDQ/MECC	t_{CISKEW}	—	—	ps	1	
1600 MT/s data rate		-112	112			1
1333 MT/s data rate		-125	125			1
1200 MT/s data rate		-142	142			1, 3
1000 MT/s data rate		-170	170			1, 3
Tolerated skew for MDQS-MDQ/MECC	t_{DISKEW}	—	—	ps	2	
1600 MT/s data rate		-200	200			2
1333 MT/s data rate		-250	250			2
1200 MT/s data rate		-275	275			2, 3
1000 MT/s data rate		-300	300			2, 3

Notes:

1. t_{CISKEW} represents the total amount of skew consumed by the controller between MDQS[n] and any corresponding bit that is captured with MDQS[n]. This must be subtracted from the total timing budget.

Table 29. DDR3L and DDR4 SDRAM interface input AC timing specifications³

Parameter	Symbol	Min	Max	Unit	Notes
2. The amount of skew that can be tolerated from MDQS to a corresponding MDQ signal is called t_{DISKEW} . This can be determined by the following equation: $t_{DISKEW} = \pm(T \div 4 - \text{abs}(t_{CISKEW}))$ where T is the clock period and $\text{abs}(t_{CISKEW})$ is the absolute value of t_{CISKEW} .					
3. DDR3L only					

This figure shows the DDR3L and DDR4 SDRAM interface input timing diagram.

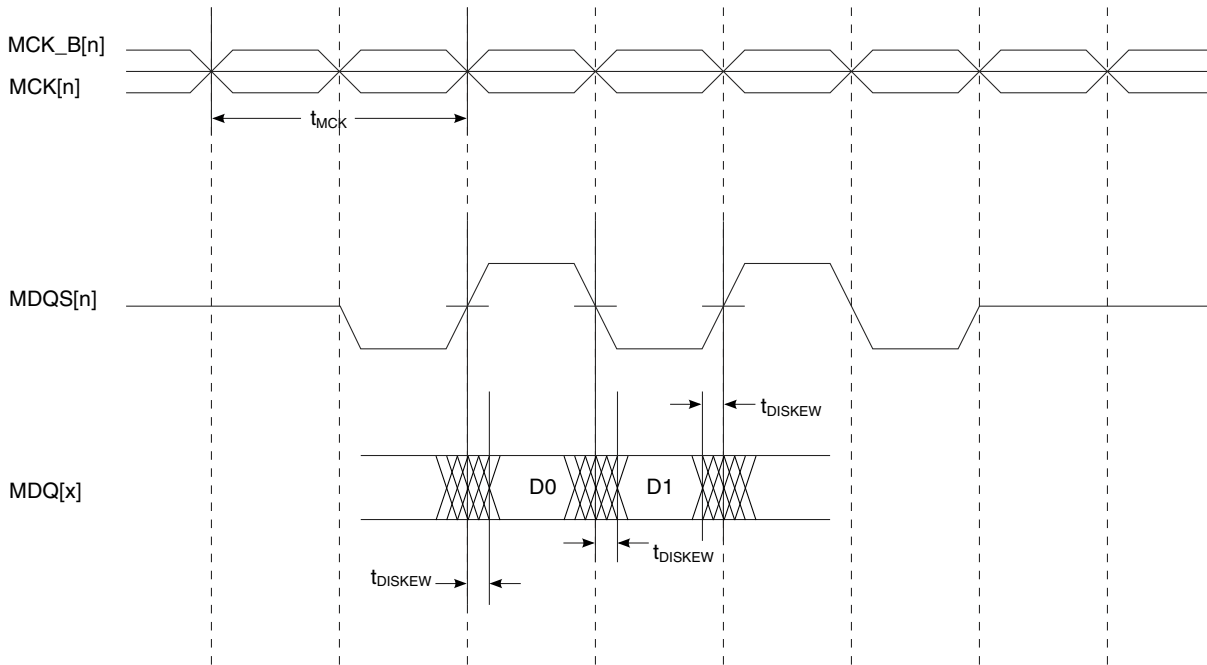

Figure 11. DDR3L and DDR4 SDRAM interface input timing diagram

3.9.2.2 DDR3L and DDR4 SDRAM interface output AC timing specifications

This table provides the output AC timing targets for the DDR3L and DDR4 SDRAM interface.

Table 30. DDR3L and DDR4 SDRAM interface output AC timing specifications⁷

Parameter	Symbol ¹	Min	Max	Unit	Notes
MCK[n] cycle time	t_{MCK}	1250	2000	ps	2
ADDR/CMD/CNTL output setup with respect to MCK	t_{DDKHAS}	—	—	ps	3
1600 MT/s data rate		495	—		3
1333 MT/s data rate		606	—		3
1200 MT/s data rate		675	—		3, 6

Table continues on the next page...

Table 30. DDR3L and DDR4 SDRAM interface output AC timing specifications⁷ (continued)

Parameter	Symbol ¹	Min	Max	Unit	Notes
1000 MT/s data rate		744	—		3, 6
ADDR/CMD/CNTL output hold with respect to MCK	t_{DDKHAX}	—	—	ps	3
1600 MT/s data rate		495	—		3
1333 MT/s data rate		606	—		3
1200 MT/s data rate		675	—		3, 6
1000 MT/s data rate		744	—		3, 6
MCK to MDQS skew	t_{DDKHMH}	—	—	ps	4
1000 MT/s data rate, \leq 1600MT/s data rate		-245	245		4, 7
MDQ/MECC/MDM output data eye	$t_{DDKXDEYE}$	—	—	ps	5
1600 MT/s data rate		400	—		5
1333 MT/s data rate		500	—		5
1200 MT/s data rate		550	—		5, 6
1000 MT/s data rate		600	—		5, 6
MDQS preamble	t_{DDKHMP}	$900 \times t_{MCK}$	—	ps	—
MDQS postamble	t_{DDKHME}	$400 \times t_{MCK}$	$600 \times t_{MCK}$	ps	—

Notes:

- The symbols used for timing specifications follow these patterns: $t_{(\text{first two letters of functional block})(\text{signal})(\text{state})(\text{reference})(\text{state})}$ for inputs and $t_{(\text{first two letters of functional block})(\text{reference})(\text{state})(\text{signal})(\text{state})}$ for outputs. Output hold time can be read as DDR timing (DD) from the rising or falling edge of the reference clock (KH or KL) until the output went invalid (AX or DX). For example, t_{DDKHAS} symbolizes DDR timing (DD) for the time t_{MCK} memory clock reference (K) goes from the high (H) state until outputs (A) are setup (S) or output valid time. Also, t_{DDKLDX} symbolizes DDR timing (DD) for the time t_{MCK} memory clock reference (K) goes low (L) until data outputs (D) are invalid (X) or data output hold time.
- All MCK/MCK_B and MDQS/MDQS_B referenced measurements are made from the crossing of the two signals. Note: The range of operating frequency for MCK are part dependent, enter the range that applies to your part.
- ADDR/CMD includes all DDR SDRAM output signals except MCK/MCK_B, MCS_B, and MDQ/MECC/MDM/MDQS.
- t_{DDKHMH} follows the symbol conventions described in note 1. For example, t_{DDKHMH} describes the DDR timing (DD) from the rising edge of the MCK[n] clock (KH) until the MDQS signal is valid (MH). t_{DDKHMH} can be modified through control of the MDQS override bits (called WR_DATA_DELAY) in the TIMING_CFG_2 register. This is typically set to the same delay as in DDR_SDRAM_CLK_CNTL[CLK_ADJUST]. The timing parameters listed in the table assume that these two parameters have been set to the same adjustment value. See the chip reference manual for a description and explanation of the timing modifications enabled by the use of these bits.
- Available eye for data (MDQ), ECC (MECC), and data mask (MDM) outputs at the pin of the processor. Memory controller will center the strobe (MDQS) in the available data eye at the DRAM (end point) during the initialization.
- DDR3L only
- It is required to program the start value of the DQS adjust for write leveling. Note: t_{DDKHMH} is required to program the start value of the DQS adjust for write leveling. This is a more relaxed timing window than meeting t_{DQSS} at the DRAM. This is why the t_{DDKHMH} numbers for 1200/1333/1600 consume a higher percentage of the timing budget.

NOTE

For the ADDR/CMD setup and hold specifications in [Table 3](#), it is assumed that the clock control register is set to adjust the memory clocks by $\frac{1}{2}$ applied cycle.

This figure shows the DDR3L and DDR4 SDRAM interface output timing for the MCK to MDQS skew measurement (t_{DDKHMH}).

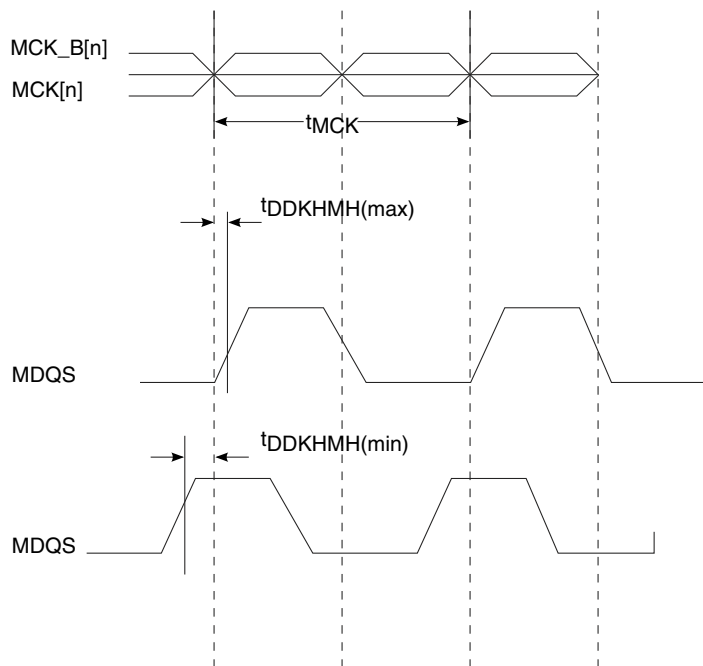

Figure 12. t_{DDKHMH} timing diagram

This figure shows the DDR3L and DDR4 SDRAM output timing diagram.

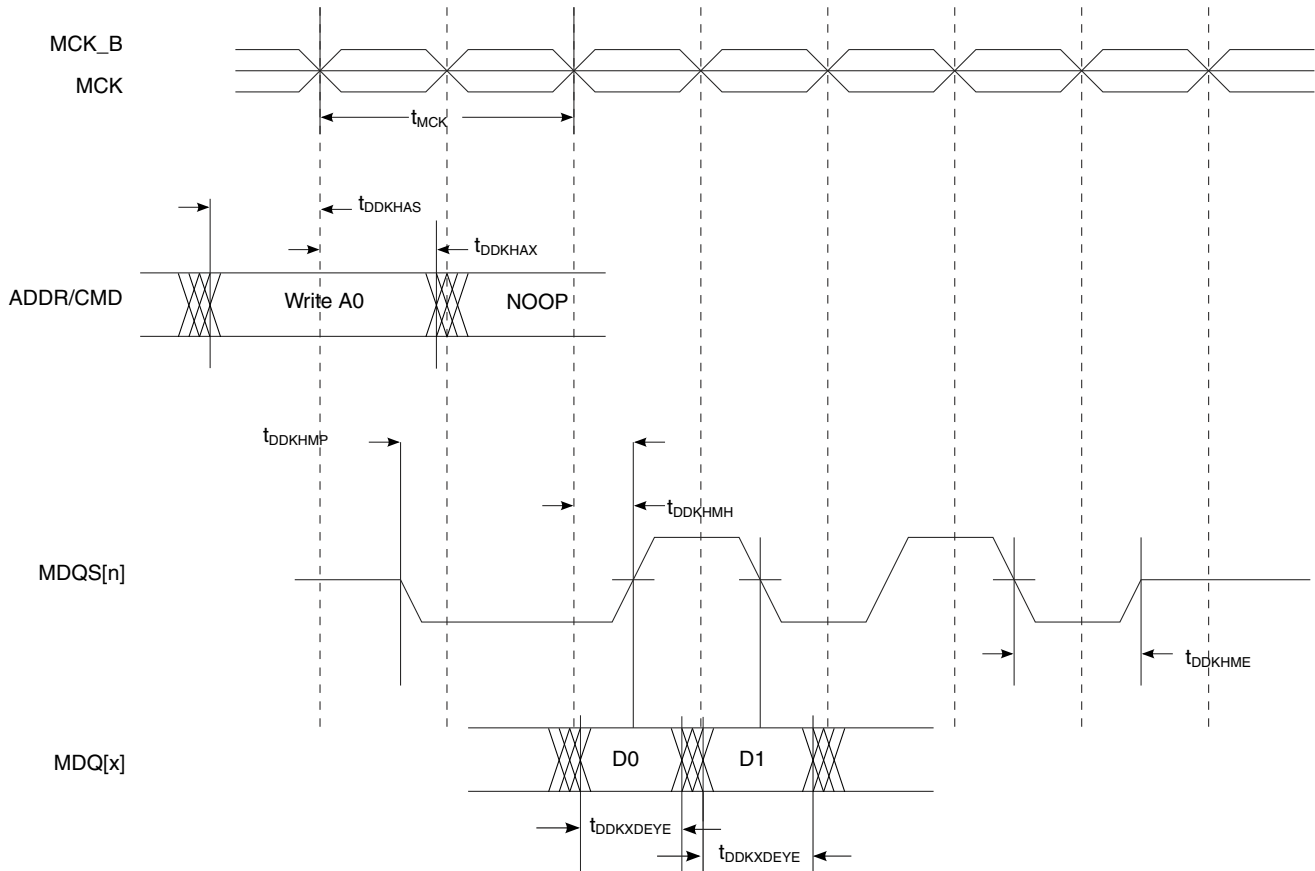

Figure 13. DDR3L and DDR4 output timing diagram

3.10 DUART interface

This section describes the DC and AC electrical specifications for the DUART interface.

3.10.1 DUART DC electrical characteristics

This table provides the DC electrical characteristics for the DUART interface at $DV_{DD}/D1V_{DD} = 3.3\text{ V}$.

Table 31. DUART DC electrical characteristics (3.3 V)³

Parameter	Symbol	Min	Max	Unit	Notes
Input high voltage	V_{IH}	$0.7 \times D1V_{DD}$	—	V	1
Input low voltage	V_{IL}	—	$0.2 \times D1V_{DD}$	V	1
Input current ($DV_{IN}/D1V_{IN} = 0\text{ V}$ or $DV_{IN} = DV_{DD}/D1V_{DD}$)	I_{IN}	—	± 50	μA	2

Table continues on the next page...

Table 31. DUART DC electrical characteristics (3.3 V)³ (continued)

Parameter	Symbol	Min	Max	Unit	Notes
Output high voltage ($I_{OH} = -2.0$ mA)	V_{OH}	2.4	—	V	—
Output low voltage ($I_{OL} = 2.0$ mA)	V_{OL}	—	0.4	V	—

Notes:

1. The min V_{IL} and max V_{IH} values are based on the respective min and max $DV_{IN}/D1V_{IN}$ values found in [Table 3](#).
2. The symbol $DV_{IN}/D1V_{IN}$ represents the input voltage of the supply referenced in [Table 3](#).
3. For recommended operating conditions, see [Table 3](#).

This table provides the DC electrical characteristics for the DUART interface at $DV_{DD}/D1V_{DD} = 1.8$ V.

Table 32. DUART DC electrical characteristics (1.8 V)³

Parameter	Symbol	Min	Max	Unit	Notes
Input high voltage	V_{IH}	$0.7 \times D1V_{DD}$	—	V	1
Input low voltage	V_{IL}	—	$0.2 \times D1V_{DD}$	V	1
Input current ($DV_{IN} = 0$ V or $DV_{IN} = DV_{DD}/D1V_{DD}$)	I_{IN}	—	± 50	μA	2
Output high voltage ($DV_{DD}/D1V_{DD} = \text{min}$, $I_{OH} = -0.5$ mA)	V_{OH}	1.35	—	V	—
Output low voltage ($DV_{DD}/D1V_{DD} = \text{min}$, $I_{OL} = 0.5$ mA)	V_{OL}	—	0.4	V	—

Notes:

1. The min V_{IL} and max V_{IH} values are based on the min and max $DV_{IN}/D1V_{IN}$ respective values found in [Table 3](#).
2. The symbol $DV_{IN}/D1V_{IN}$ represents the input voltage of the supply referenced in [Table 3](#).
3. For recommended operating conditions, see [Table 3](#).

3.10.2 DUART AC timing specifications

This table provides the AC timing specifications for the DUART interface.

Table 33. DUART AC timing specifications

Parameter	Value	Unit	Notes
Minimum baud rate	$f_{PLAT}/(2 \times 1,048,576)$	baud	1, 3
Maximum baud rate	$f_{PLAT}/(2 \times 16)$	baud	1, 2

Notes:

1. f_{PLAT} refers to the internal platform clock.
2. The actual attainable baud rate is limited by the latency of interrupt processing.
3. The middle of a start bit is detected as the eighth sampled 0 after the 1-to-0 transition of the start bit. Subsequent bit values are sampled each 16th sample.

3.11 Ethernet interface, Ethernet management interface, IEEE Std 1588™

This section describes the DC and AC electrical characteristics for the Ethernet controller, Ethernet management, and IEEE Std 1588 interfaces.

3.11.1 SGMII interface

Each SGMII port features a 4-wire AC-coupled serial link from the SerDes interface of the chip, as shown in [Figure 14](#), where C_{TX} is the external (on board) AC-coupled capacitor. Each SerDes transmitter differential pair features 100- Ω output impedance. Each input of the SerDes receiver differential pair features 50- Ω on-die termination to XGND $_n$. The reference circuit of the SerDes transmitter and receiver is shown in [Figure 79](#).

3.11.1.1 SGMII clocking requirements for SD1_REF_CLK1_P and SD1_REF_CLK1_N

When operating in SGMII mode, the EC $_n$ _GTX_CLK125 clock is not required for this port. Instead, a SerDes reference clock is required on SD1_REF_CLK[1:2]_P and SD1_REF_CLK[1:2]_N pins. SerDes lanes may be used for SerDes SGMII configurations based on the RCW Configuration field SRDS_PRTCL.

For more information on these specifications, see [SerDes reference clocks](#).

3.11.1.2 SGMII DC electrical characteristics

This section describes the electrical characteristics for the SGMII interface.

3.11.1.2.1 SGMII transmit DC electrical characteristics

This table provides the SGMII SerDes transmitter AC-coupled DC electrical characteristics. Transmitter DC characteristics are measured at the transmitter outputs (SD $_n$ _TX $_n$ _P and SD $_n$ _TX $_n$ _N), as shown in [Figure 15](#).

Table 34. SGMII DC transmitter electrical characteristics (X1V_{DD} = 1.35 V)⁴

Parameter	Symbol	Min	Typ	Max	Unit	Notes
Output high voltage	V _{OH}	—	—	1.35 x V _{OD} max	mV	1
Output low voltage	V _{OL}	V _{OD} _{-min} /2	—	—	mV	1

Table continues on the next page...

Electrical characteristics

Table 34. SGMII DC transmitter electrical characteristics (X1V_{DD} = 1.35 V)⁴ (continued)

Parameter	Symbol	Min	Typ	Max	Unit	Notes
Output differential voltage (XV _{DD-Typ} at 1.35 V)	V _{OD}	320	500.0	725.0	mV	2, 3
		293.8	459.0	665.6		—
		266.9	417.0	604.7		—
		240.6	376.0	545.2		—
		213.1	333.0	482.9		—
		186.9	292.0	423.4		—
		160.0	250.0	362.5		—
Output impedance (differential)	R _O	80	100	120	Ω	—

Notes:

1. This does not align to DC-coupled SGMII.
2. $|V_{OD}| = |V_{SD_TXn_P} - V_{SD_TXn_N}|$. |V_{OD}| is also referred to as output differential peak voltage. $V_{TX-DIFFp-p} = 2 \times |V_{OD}|$.
3. The |V_{OD}| value shown in the Typ column is based on the condition of X1V_{DD-Typ} = 1.35 V, no common mode offset variation. SerDes transmitter is terminated with 100-Ω differential load between SDn_TXn_P and SDn_TXn_N.
4. For recommended operating conditions, see [Table 3](#).

This figure shows an example of a 4-wire AC-coupled SGMII serial link connection.

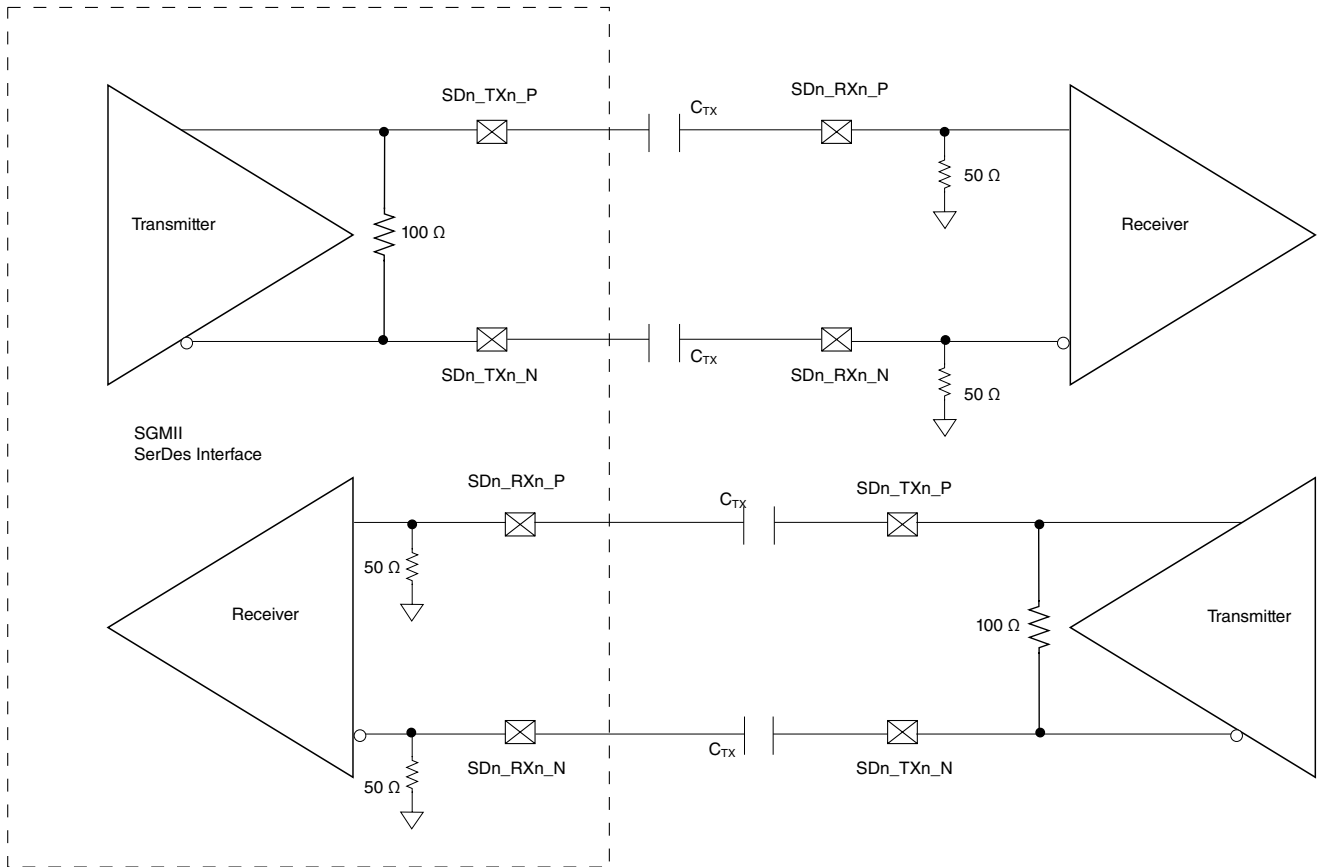

Figure 14. 4-wire AC-coupled SGMII serial link connection example

This figure shows the SGMII transmitter DC measurement circuit.

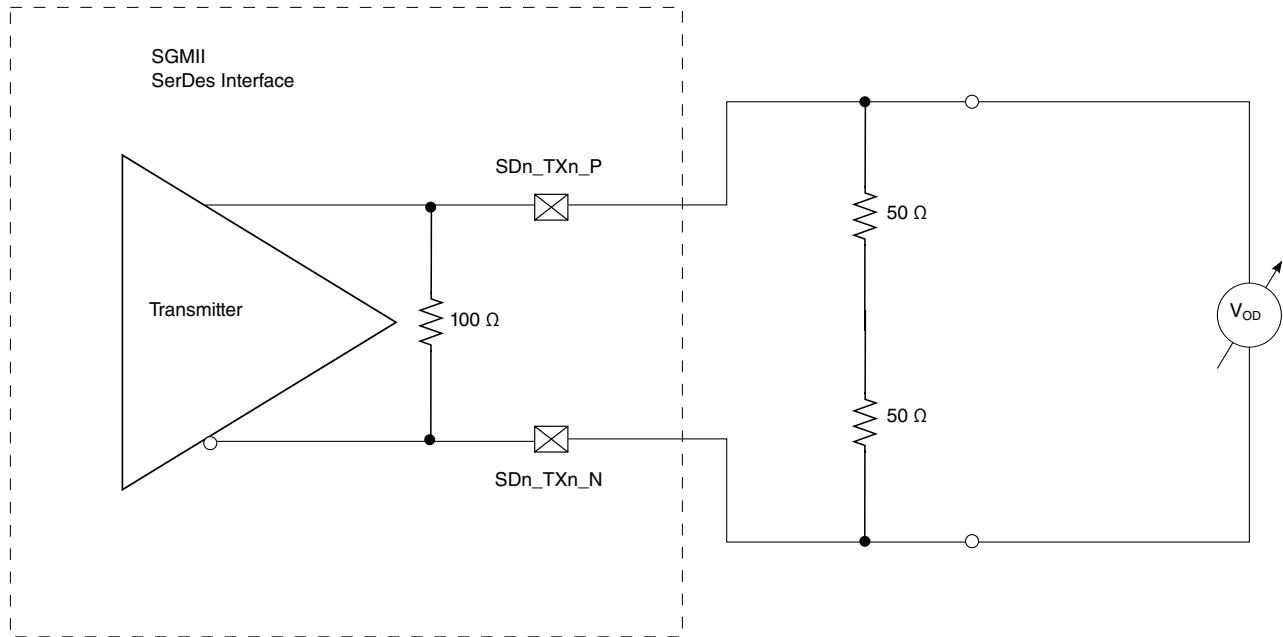

Figure 15. SGMII transmitter DC measurement circuit

3.11.1.2.2 SGMII receiver DC electrical characteristics

This table provides the SGMII receiver DC electrical characteristics. Source-synchronous clocking is not supported. Clock is recovered from the data.

Table 35. SGMII receiver DC electrical characteristics (S1V_{DD} = 1.0V)⁴

Parameter	Symbol	Min	Typ	Max	Unit	Notes
DC input voltage range	—	N/A			—	1
Input differential voltage	V _{RX_DIFFp-p}	100	—	1200	mV	2
		175	—			
Loss of signal threshold	V _{LOS}	30	—	100	mV	3
		65	—	175		
Receiver differential input impedance	Z _{RX_DIFF}	80	—	120	Ω	—

Notes:

1. Input must be externally AC coupled.
2. V_{RX_DIFFp-p} is also referred to as peak-to-peak input differential voltage.
3. The concept of this parameter is equivalent to the electrical idle detect threshold parameter in PCI Express. For further explanation, see [PCI Express DC physical layer receiver specifications](#), and [PCI Express AC physical layer receiver specifications](#).
4. For recommended operating conditions, see [Table 3](#).

3.11.1.3 SGMII AC timing specifications

This section describes the AC timing specifications for the SGMII interface.

3.11.1.3.1 SGMII transmit AC timing specifications

This table provides the SGMII transmit AC timing specifications. Source-synchronous clocking is not supported. The AC timing specifications do not include RefClk jitter.

Table 36. SGMII transmit AC timing specifications⁴

Parameter	Symbol	Min	Typ	Max	Unit	Notes
Deterministic jitter	JD	—	—	0.17	UI p-p	—
Total jitter	JT	—	—	0.35	UI p-p	2
Unit Interval: 1.25 GBaud (SGMII)	UI	800 - 100 ppm	800	800 + 100 ppm	ps	1
AC coupling capacitor	C_{TX}	10	—	200	nF	3

Notes:

- Each UI is 800 ps \pm 100 ppm or 320 ps \pm 100 ppm.
- See [Figure 17](#) for single frequency sinusoidal jitter measurements.
- The external AC coupling capacitor of 100 nF is required. It is recommended to place it near the device transmitter outputs.
- For recommended operating conditions, see [Table 3](#).

3.11.1.3.2 SGMII AC measurement details

Transmitter and receiver AC characteristics are measured at the transmitter outputs (SDn_TXn_P and SDn_TXn_N) or at the receiver inputs (SDn_RXn_P and SDn_RXn_N) respectively, as shown in this figure.

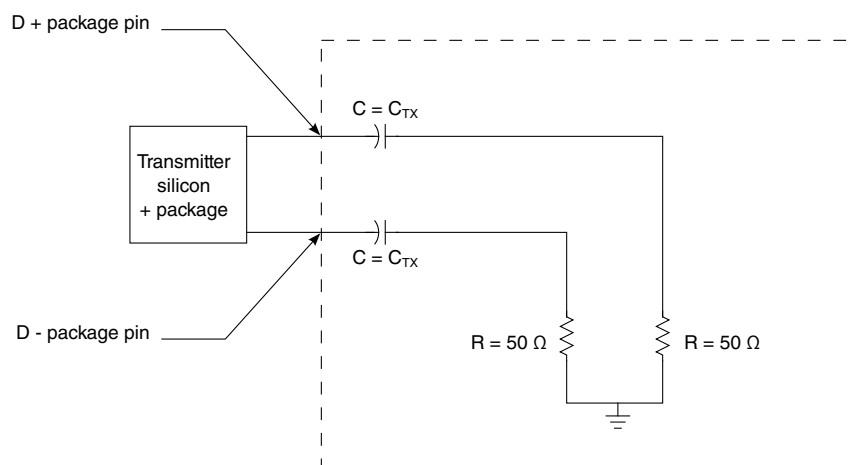

Figure 16. SGMII AC test/measurement load

3.11.1.3.3 SGMII receiver AC timing specifications

This table provides the SGMII receiver AC timing specifications. Source-synchronous clocking is not supported. Clock is recovered from the data. These AC timing specifications do not include RefClk jitter.

Table 37. SGMII Receive AC timing specifications³

Parameter	Symbol	Min	Typ	Max	Unit	Notes
Deterministic jitter tolerance	J _D	—	—	0.37	UI p-p	1
Combined deterministic and random jitter tolerance	J _{DR}	—	—	0.55	UI p-p	1
Total jitter tolerance	J _T	—	—	0.65	UI p-p	1, 2
Bit error ratio	BER	—	—	10 ⁻¹²	—	—
Unit Interval: 1.25 GBaud (SGMII)	UI	800 - 100 ppm	800	800 + 100 ppm	ps	1
Notes:						
1. Measured at the receiver.						
2. Total jitter tolerance is composed of three components: deterministic jitter, random jitter, and single-frequency sinusoidal jitter. The sinusoidal jitter may have any amplitude and frequency in the unshaded region of Figure 17 . The sinusoidal jitter component is included to ensure margin for low frequency jitter, wander, noise, crosstalk, and other variable system effects.						
3. For recommended operating conditions, see Table 3 .						

The sinusoidal jitter in the total jitter tolerance may have any amplitude and frequency in the unshaded region of this figure.

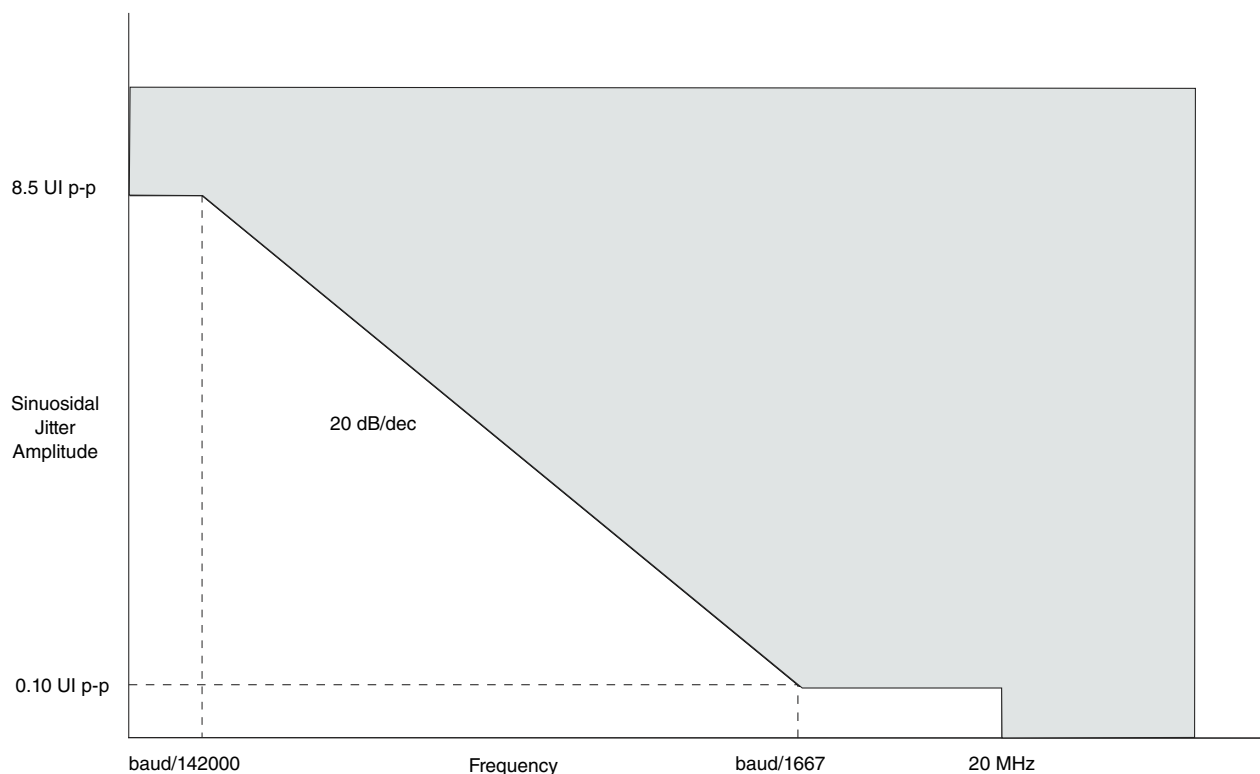

Figure 17. Single-frequency sinusoidal jitter limits

3.11.2 RGMII electrical specifications

This section describes the electrical characteristics for the RGMII interface.

3.11.2.1 RGMII DC electrical characteristics

This table provides the DC electrical characteristics for the RGMII interface at LV_{DD} , $L1V_{DD} = 2.5$ V.

Table 38. RGMII DC electrical characteristics (LV_{DD} , $L1V_{DD} = 2.5$ V)⁴

Parameters	Symbol	Min	Max	Unit	Notes
Input high voltage	V_{IH}	$0.7 \times L1V_{DD}$	—	V	1
Input low voltage	V_{IL}	—	$0.2 \times L1V_{DD}$	V	1
Input current ($LV_{IN}=0$ V or $LV_{IN}=LV_{DD}$)	I_{IH}	—	± 50	μ A	2, 3
Output high voltage ($LV_{DD} = \text{min}$, $I_{OH} = -1.0$ mA)	V_{OH}	2.00	—	V	3
Output low voltage ($LV_{DD} = \text{min}$, $I_{OL} = 1.0$ mA)	V_{OL}	—	0.4	V	3

Notes:

1. The min V_{IL} and max V_{IH} values are based on the respective min and max LV_{IN} values found in [Table 3](#).
2. The symbol LV_{IN} , in this case, represents the LV_{IN} and $L1V_{IN}$ symbol referenced in [Table 3](#).

Electrical characteristics

Table 38. RGMII DC electrical characteristics (LV_{DD}, L1V_{DD} = 2.5 V)⁴

Parameters	Symbol	Min	Max	Unit	Notes
3. The symbol LV _{DD} , in this case, represents the LV _{DD} and L1V _{DD} symbol referenced in Table 3 .					
4. For recommended operating conditions, see Table 3 .					

This table provides the DC electrical characteristics for the RGMII interface at LV_{DD}, L1V_{DD} = 1.8 V.

Table 39. RGMII DC electrical characteristics (LV_{DD}, L1V_{DD} = 1.8 V)⁴

Parameter	Symbol	Min	Max	Unit	Notes
Input high voltage	V _{IH}	0.7 x L1V _{DD}	—	V	1
Input low voltage	V _{IL}	—	0.2 x L1V _{DD}	V	1
Input current (LV _{IN} = 0 V or L1V _{IN} = LV _{DD})	I _{IN}	—	±50	µA	2, 3
Output high voltage (LV _{DD} = min, I _{OH} = -0.5 mA)	V _{OH}	1.35	—	V	3
Output low voltage (LV _{DD} = min, I _{OL} = 0.5 mA)	V _{OL}	—	0.4	V	3

Notes:

- The min V_{IL} and max V_{IH} values are based on the min and max LV_{IN} values found in [Table 3](#).
- The symbol LV_{IN}, in this case, represents the LV_{IN} and L1V_{IN} symbol referenced in [Table 3](#).
- The symbol LV_{DD}, in this case, represents the LV_{DD} and L1V_{DD} symbol referenced in [Table 3](#).
- For recommended operating conditions, see [Table 3](#).

3.11.2.2 RGMII AC timing specifications

This table provides the RGMII AC timing specifications.

Table 40. RGMII AC timing specifications (LV_{DD}, L1V_{DD} = 2.5 / 1.8 V)⁸

Parameter/Condition	Symbol ¹	Min	Typ	Max	Unit	Notes
Data to clock output skew (at transmitter)	t _{SKRGT_TX}	-770	0	700	ps	7
Data to clock input skew (at receiver)	t _{SKRGT_RX}	1.4	—	2.6	ns	2
Clock period duration	t _{RGT}	7.2	8.0	8.8	ns	3
Duty cycle for 10BASE-T and 100BASE-TX	t _{RGTH} /t _{RGT}	40	50	60	%	3, 4
Duty cycle for Gigabit	t _{RGTH} /t _{RGT}	45	50	55	%	—
Rise time (20%-80%)	t _{RGTR}	—	—	—	ns	5, 6
L1/LV _{DD} = 2.5V				0.75		
L1/LV _{DD} = 1.8V				0.54		
Fall time (20%-80%)	t _{RGTF}	—	—	—	ns	5, 6
L1/LV _{DD} = 2.5V				0.75		
L1/LV _{DD} = 1.8V				0.54		

Table continues on the next page...

Table 40. RGMII AC timing specifications (LV_{DD} , $L1V_{DD} = 2.5 / 1.8 V$)⁸ (continued)

Parameter/Condition	Symbol ¹	Min	Typ	Max	Unit	Notes
Notes:						
1. In general, the clock reference symbol representation for this section is based on the symbols RGT to represent RGMII timing. Note that the notation for rise (R) and fall (F) times follows the clock symbol that is being represented. For symbols representing skews, the subscript is skew (SK) followed by the clock that is being skewed (RGT).						
2. This implies that PC board design will require clocks to be routed such that an additional trace delay of greater than 1.5 ns is added to the associated clock signal. Many PHY vendors already incorporate the necessary delay inside their device. If so, additional PCB delay is probably not needed.						
3. For 10 and 100 Mbps, t_{RGT} scales to $400 \text{ ns} \pm 40 \text{ ns}$ and $40 \text{ ns} \pm 4 \text{ ns}$, respectively.						
4. Duty cycle may be stretched/shrunk during speed changes or while transitioning to a received packet's clock domains as long as the minimum duty cycle is not violated and stretching occurs for no more than three t_{RGT} of the lowest speed transitioned between.						
5. Applies to inputs and outputs.						
6. The system/board must be designed to ensure this input requirement to the chip is achieved. Proper device operation is guaranteed for inputs meeting this requirement by design, simulation, characterization, or functional testing.						
7. The frequency of ECn_RX_CLK (input) should not exceed the frequency of ECn_GTX_CLK (output) by more than 300 ppm.						
8. For recommended operating conditions, see Table 3 .						

This figure shows the RGMII AC timing and multiplexing diagrams.

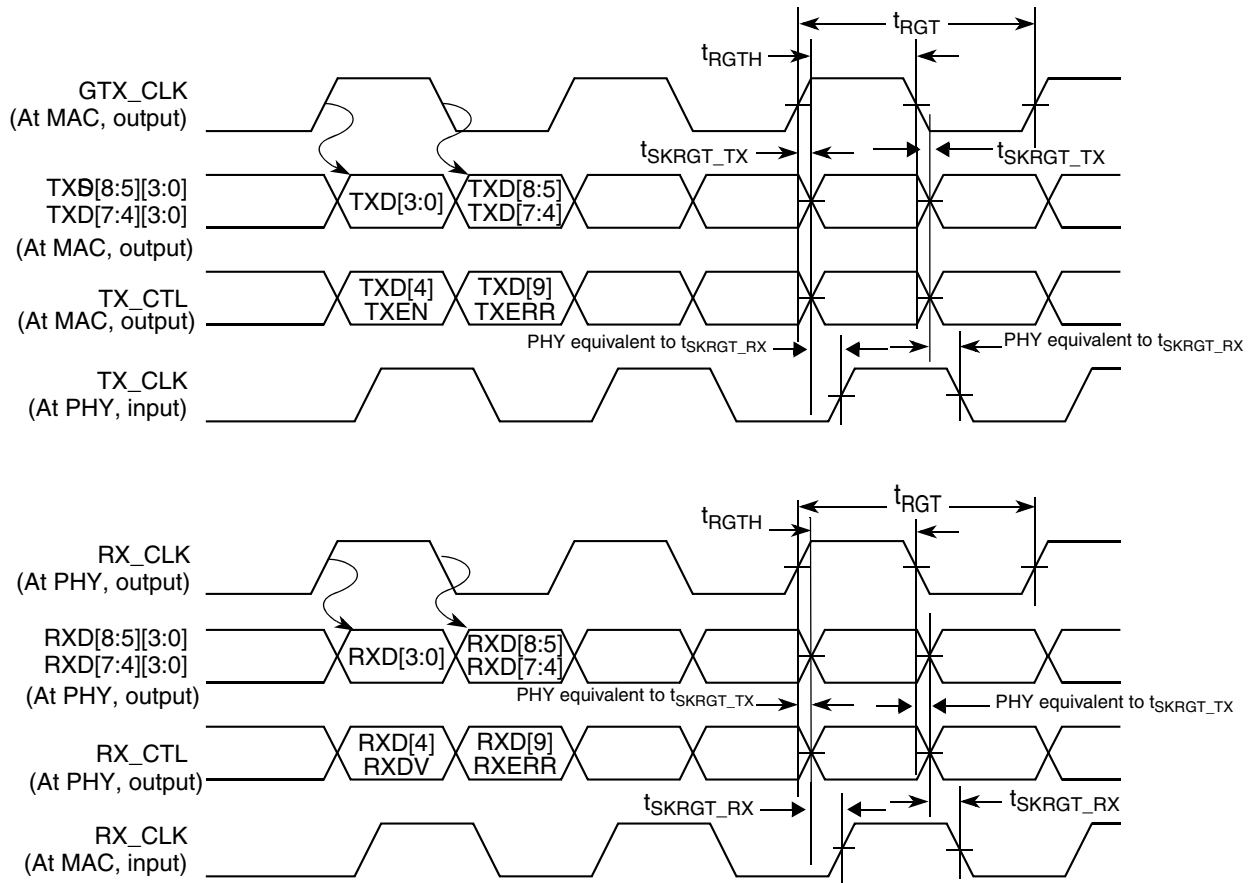

Figure 18. RGMII AC timing and multiplexing diagrams

Warning

NXP guarantees timings generated from the MAC. Board designers must ensure delays needed at the PHY or the MAC.

3.11.3 MII, RMII electrical specifications

This section describes the electrical characteristics for the MII and RMII interfaces.

3.11.3.1 MII, RMII DC electrical characteristics

This table provides the MII and RMII DC electrical characteristics when operating at V_{DD} , $L1V_{DD} = 3.3$ V.

Table 41. MII and RMI DC electrical characteristics

Parameter	Symbol	Min	Max	Unit	Notes
Input high voltage	V_{IH}	$0.7 \times L1V_{DD}$	—	V	1
Input low voltage	V_{IL}	—	$0.2 \times L1V_{DD}$	V	—
Input high current ($V_{IN} = L1V_{DD}$)	I_{IH}	—	50	μA	2
Input low current ($V_{IN} = GND$)	I_{IL}	-50	—	μA	2
Output high voltage ($L1V_{DD} = \text{min}$, $I_{OH} = -2.0 \text{ mA}$)	V_{OH}	2.4	—	V	—
Output low voltage ($L1V_{DD} = \text{min}$, $I_{OL} = 2.0 \text{ mA}$)	V_{OL}	—	0.40	V	—

Notes:

- The min V_{IL} and max V_{IH} values are based on the respective min and max $L1V_{IN}$ values found in [Table 3](#)
- The symbol V_{IN} , in this case, represents the $L1V_{IN}$ symbol referenced in [Table 3](#)

3.11.3.2 MII AC timing specifications

This table describes the MII transmit and receive AC timing specifications.

Table 42. MII transmit AC timing specifications

Parameter	Symbol	Min	Typ	Max	Unit
TX_CLK clock period 10 Mbps	t_{MTX}	—	400	—	ns
TX_CLK clock period 100 Mbps	t_{MTX}	—	40	—	ns
TX_CLK duty cycle	t_{MTXH}/t_{MTX}	35	—	65	%
TX_CLK to MII data TXD[3:0], TX_ER, TX_EN delay	t_{MTKHDX}	0	—	25	ns
TX_CLK data clock rise (20%-80%)	t_{MTXR}	1.0	—	4.0	ns
TX_CLK data clock fall (80%-20%)	t_{MTXF}	1.0	—	4.0	ns

This figure shows the MII transmit AC timing diagram.

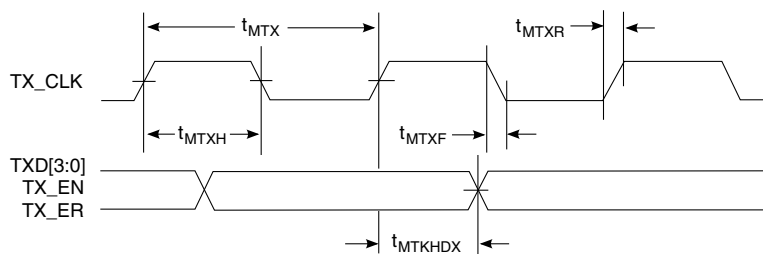
**Figure 19. MII transmit AC timing diagram**

This table provides the MII receive AC timing specifications.

Table 43. MII receive AC timing specifications¹

Parameter	Symbol	Min	Typ	Max	Unit
RX_CLK clock period 10 Mbps	t_{MRX}	—	400	—	ns
RX_CLK clock period 100 Mbps	t_{MRX}	—	40	—	ns
RX_CLK duty cycle	t_{MRXH}/t_{MRX}	35	—	65	%
RXD[3:0], RX_DV, RX_ER setup time to RX_CLK	t_{MRDVKH}	10.0	—	—	ns
RXD[3:0], RX_DV, RX_ER hold time to RX_CLK	t_{MRDXKH}	10.0	—	—	ns
RX_CLK clock rise (20%-80%)	t_{MRXR}	1.0	—	4.0	ns
RX_CLK clock fall time (80%-20%)	t_{MRXF}	1.0	—	4.0	ns

Note:

1. The frequency of RX_CLK (input) should not exceed the frequency of TX_CLK (input) by more than 300 ppm.

This figure shows the AC test load for the Ethernet controller.

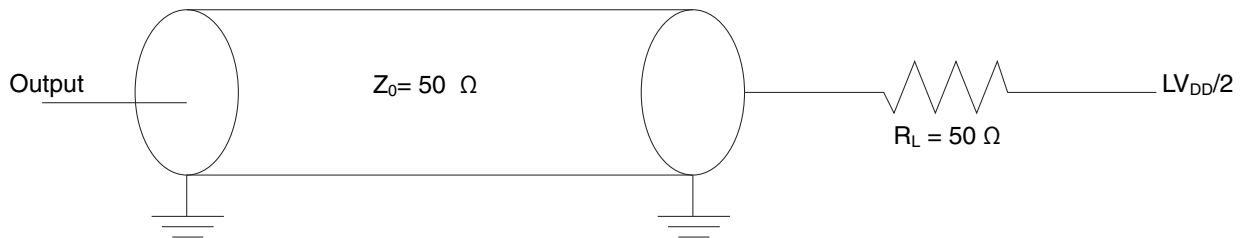

Figure 20. Ethernet controller AC test load

This figure shows the MII receive AC timing diagram.

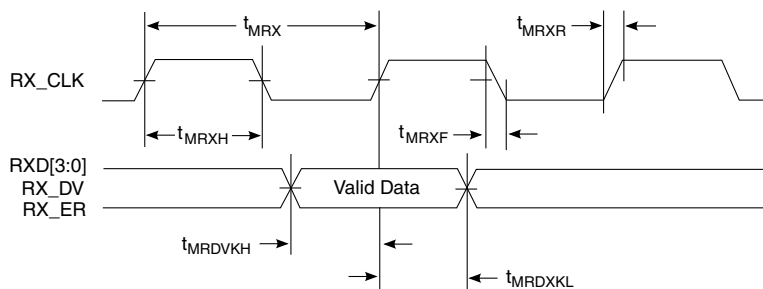

Figure 21. MII receive AC timing diagram

3.11.4 RMI AC timing specifications

In RMI mode, the reference clock should be fed to TSECn_TX_CLK. This section describes the RMI transmit and receive AC timing specifications.

This table provides the RMI transmit AC timing specifications.

Table 44. RMI transmit AC timing specifications¹

Parameter	Symbol	Min	Typ	Max	Unit
TSECn_TX_CLK clock period	t_{RMT}	—	20.0	—	ns
TSECn_TX_CLK duty cycle	t_{RMTH}	35	—	65	%
TSECn_TX_CLK peak-to-peak jitter	t_{RMTJ}	—	—	250	ps
Rise time TSECn_TX_CLK (20%-80%)	t_{RMTR}	1.0	—	5.0	ns
Fall time TSECn_TX_CLK (80%-20%)	t_{RMTF}	1.0	—	5.0	ns
TSECn_TX_CLK to RMI data TXD[1:0], TX_EN delay	t_{RMTDX}	2.0	—	10.0	ns

This figure shows the RMI transmit AC timing diagram.

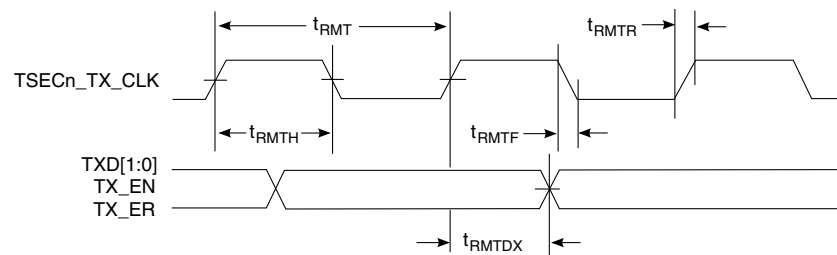

Figure 22. RMI transmit AC timing diagram

This table provides the RMI receive AC timing specifications.

Table 45. RMI receive AC timing specifications¹

Parameter	Symbol	Min	Typ	Max	Unit
TSECn_TX_CLK clock period	t_{RMR}	—	20.0	—	ns
TSECn_TX_CLK duty cycle	t_{RMRH}	35	—	65	%
TSECn_TX_CLK peak-to-peak jitter	t_{RMRJ}	—	—	250	ps
Rise time TSECn_TX_CLK (20%-80%)	t_{RMRR}	1.0	—	5.0	ns
Fall time TSECn_TX_CLK (80%-20%)	t_{RMRF}	1.0	—	5.0	ns
RXD[1:0], CRS_DV, RX_ER set-up time to TSECn_TX_CLK rising edge	t_{RMRDV}	4.0	—	—	ns
RXD[1:0], CRS_DV, RX_ER hold time to TSECn_TX_CLK rising edge	t_{RMRDX}	2.0	—	—	ns

This figure shows the AC test load for Ethernet controller.

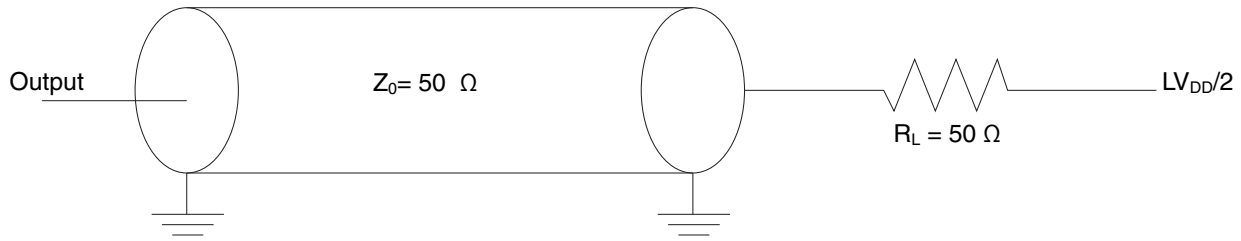

Figure 23. Ethernet controller AC test load

This figure shows the RMIi receive AC timing diagram.

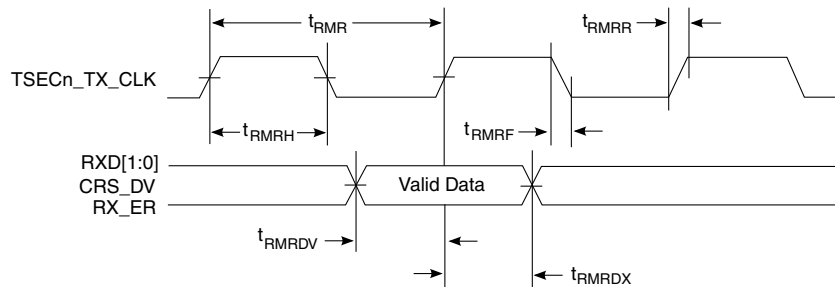

Figure 24. RMIi receive AC timing diagram

3.11.5 Ethernet management interface 1 (EMI1)

This section describes the electrical characteristics for the EMI1 interface.

The EMI1 interface timing is compatible with IEEE Std 802.3™ clause 22.

3.11.5.1 EMI1 DC electrical characteristics

This section describes the DC electrical characteristics for EMI1_MDIO and EMI1_MDC. The pins are available on L1V_{DD}. Please refer to Table 3 for operating voltages.

This table provides the EMI1 DC electrical characteristics when L1V_{DD} = 3.3 V.

Table 46. EMI1 DC electrical characteristics (L1V_{DD} = 3.3 V)²

Parameter	Symbol	Min	Max	Unit	Notes
Input high voltage	V _{IH}	0.7 x L1V _{DD}	—	V	1
Input low voltage	V _{IL}	—	0.2 x L1V _{DD}	V	1
Input current (L1V _{IN} = 0 V or L1V _{IN} = L1V _{DD})	I _{IN}	—	±50	µA	—

Table continues on the next page...

Table 46. EMI1 DC electrical characteristics (L1V_{DD} = 3.3 V)² (continued)

Parameter	Symbol	Min	Max	Unit	Notes
Output high voltage (L1V _{DD} = min, I _{OH} = -2 mA)	V _{OH}	2.4	—	V	—
Output low voltage (L1V _{DD} = min, I _{OL} = 2 mA)	V _{OL}	—	0.4	V	—

Notes:

1. The min V_{IL} and max V_{IH} values are based on the respective min and max L1V_{IN} values found in [Table 3](#).
2. For recommended operating conditions, see [Table 3](#).

This table provides the EMI1 DC electrical characteristics when L1V_{DD} = 2.5 V.

Table 47. EMI1 DC electrical characteristics (L1V_{DD} = 2.5 V)²

Parameters	Symbol	Min	Max	Unit	Notes
Input high voltage	V _{IH}	0.7 x L1V _{DD}	—	V	1
Input low voltage	V _{IL}	—	0.2 x L1V _{DD}	V	1
Input current (L1V _{IN} = 0 or L1V _{IN} = L1V _{DD})	I _{IN}	—	±50	µA	—
Output high voltage (L1V _{DD} = min, I _{OH} = -1.0 mA)	V _{OH}	2.00	—	V	—
Output low voltage (L1V _{DD} = min, I _{OL} = 1.0 mA)	V _{OL}	—	0.40	V	—

Notes:

1. The min V_{IL} and max V_{IH} values are based on the respective min and max L1V_{IN} values found in [Table 3](#).
2. For recommended operating conditions, see [Table 3](#).

This table provides the EMI1 DC electrical characteristics when L1V_{DD} = 1.8 V.

Table 48. EMI1 DC electrical characteristics (L1V_{DD} = 1.8 V)²

Parameter	Symbol	Min	Max	Unit	Notes
Input high voltage	V _{IH}	0.7 x L1V _{DD}	—	V	1
Input low voltage	V _{IL}	—	0.2 x L1V _{DD}	V	1
Input current (L1V _{IN} = 0 V or L1V _{IN} = L1V _{DD})	I _{IN}	—	±50	µA	—
Output high voltage (L1V _{DD} = min, I _{OH} = -0.5 mA)	V _{OH}	1.35	—	V	—
Output low voltage (L1V _{DD} = min, I _{OL} = 0.5 mA)	V _{OL}	—	0.4	V	—

Notes:

1. The min V_{IL} and max V_{IH} values are based on the min and max L1V_{IN} respective values found in [Table 3](#).
2. For recommended operating conditions, see [Table 3](#).

3.11.5.2 EMI1 AC timing specifications

This table provides the EMI1 AC timing specifications.

Table 49. EMI1 AC timing specifications⁵

Parameter/Condition	Symbol ¹	Min	Typ	Max	Unit	Notes
MDC frequency	f _{MDC}	—	—	2.5	MHz	2
MDC clock pulse width high	t _{MDCH}	160	—	—	ns	—
MDC to MDIO delay	t _{MDKHDX}	(3 x t _{enet_clk}) - 3	—	(5 x t _{enet_clk}) + 3	ns	3, 4
MDIO to MDC setup time	t _{MDDVKH}	8	—	—	ns	—
MDIO to MDC hold time	t _{MDDXKH}	0	—	—	ns	—

Notes:

1. The symbols used for timing specifications follow these patterns: t_{(first two letters of functional block)(signal)(state)(reference)(state)} for inputs and t_{(first two letters of functional block)(reference)(state)(signal)(state)} for outputs. For example, t_{MDKHDX} symbolizes management data timing (MD) for the time t_{MDC} from clock reference (K) high (H) until data outputs (D) are invalid (X) or data hold time. Also, t_{MDDVKH} symbolizes management data timing (MD) with respect to the time data input signals (D) reach the valid state (V) relative to the t_{MDC} clock reference (K) going to the high (H) state or setup time.
2. This parameter is dependent on the Ethernet clock frequency. The eTSEC_MDIO_MIIMCFG[MgmtClk] field determines the clock frequency of the MII management clock.
3. This parameter is dependent on the Ethernet clock frequency (CCB clock)/2. The delay is equal to 3 Ethernet clock periods ± 3 ns. For example, with an Ethernet clock of 400 MHz, the min/max delay is 12.5 ns ± 3 ns.
4. t_{enet_clk} is the Ethernet clock period (Ethernet clock period x 2).
5. For recommended operating conditions, see [Table 3](#).

3.11.6 IEEE 1588 electrical specifications

3.11.6.1 IEEE 1588 DC electrical characteristics

This table provides the IEEE 1588 DC electrical characteristics when operating at LV_{DD} = 2.5 V supply.

Table 50. IEEE 1588 DC electrical characteristics(LV_{DD} = 2.5 V)³

Parameters	Symbol	Min	Max	Unit	Notes
Input high voltage	V _{IH}	0.7 x LV _{DD}	—	V	1
Input low voltage	V _{IL}	—	0.2 x LV _{DD}	V	1
Input current (LV _{IN} = 0 V or LV _{IN} = LV _{DD})	I _{IH}	—	±50	µA	2
Output high voltage (LV _{DD} = min, I _{OH} = -1.0 mA)	V _{OH}	2.00	—	V	—
Output low voltage (LV _{DD} = min, I _{OL} = 1.0 mA)	V _{OL}	—	0.40	V	—

Notes:

1. The min V_{IL} and max V_{IH} values are based on the respective min and max LV_{IN} values found in [Table 3](#).
2. The symbol LV_{IN}, in this case, represents the LV_{IN} symbol referenced in [Table 3](#).
3. For recommended operating conditions, see [Table 3](#).

This table provides the IEEE 1588 DC electrical characteristics when operating at LV_{DD} = 1.8 V supply.

Table 51. IEEE 1588 DC electrical characteristics(LV_{DD} = 1.8 V)³

Parameters	Symbol	Min	Max	Unit	Notes
Input high voltage	V _{IH}	0.7 x LV _{DD}	—	V	1
Input low voltage	V _{IL}	—	0.2 x LV _{DD}	V	1
Input current (LV _{IN} = 0 V or LV _{IN} = LV _{DD})	I _{IH}	—	±50	μA	2
Output high voltage (LV _{DD} = min, I _{OH} = -0.5 mA)	V _{OH}	1.35	—	V	—
Output low voltage (LV _{DD} = min, I _{OL} = 0.5 mA)	V _{OL}	—	0.40	V	—

Notes:

1. The min V_{IL} and max V_{IH} values are based on the respective min and max LV_{IN} values found in [Table 3](#).
2. The symbol LV_{IN}, in this case, represents the LV_{IN} symbol referenced in [Table 3](#).
3. For recommended operating conditions, see [Table 3](#).

3.11.6.2 IEEE 1588 AC timing specifications

This table provides the IEEE 1588 AC timing specifications.

Table 52. IEEE 1588 AC timing specifications⁵

Parameter/Condition	Symbol	Min	Typ	Max	Unit	Notes
TSEC_1588_CLK_IN clock period	t _{T1588CLK}	FM_CLK/2	—	T _{RX_CLK} x 7	ns	1, 3
TSEC_1588_CLK_IN duty cycle	t _{T1588CLKH} / t _{T1588CLK}	40	50	60	%	2
TSEC_1588_CLK_IN peak-to-peak jitter	t _{T1588CLKINJ}	—	—	250	ps	—
Rise time TSEC_1588_CLK_IN (20%-80%)	t _{T1588CLKINR}	1.0	—	2.0	ns	—
Fall time TSEC_1588_CLK_IN (80%-20%)	t _{T1588CLKINF}	1.0	—	2.0	ns	—
TSEC_1588_CLK_OUT clock period	t _{T1588CLKOUT}	5.0	—	—	ns	4
TSEC_1588_CLK_OUT duty cycle	t _{T1588CLKOTH} / t _{T1588CLKOUT}	30	50	70	%	—
TSEC_1588_PULSE_OUT1/2, TSEC_1588_ALARM_OUT1/2	t _{T1588OV}	-0.85	—	3.8	ns	—
TSEC_1588_TRIG_IN1/2 pulse width	t _{T1588TRIGH}	2 x t _{T1588CLK_MAX}	—	—	ns	3

Notes:

1. T_{RX_CLK} is the maximum clock period of the ethernet receiving clock selected by TMR_CTRL[CKSEL]. See the chip reference manual for a description of TMR_CTRL registers.
2. This needs to be at least two times the clock period of the clock selected by TMR_CTRL[CKSEL]. See the chip reference manual for a description of TMR_CTRL registers.
3. The maximum value of t_{T1588CLK} is not only defined by the value of T_{RX_CLK}, but also defined by the recovered clock. For example, for 10/100/1000 Mbps modes, the maximum value of t_{T1588CLK} will be 2800, 280, and 56 ns, respectively.
4. There are three input clock sources for 1588: TSEC_1588_CLK_IN, RTC, and MAC clock / 2. When using TSEC_1588_CLK_IN, the minimum clock period is 2 x t_{T1588CLK}.
5. For recommended operating conditions, see [Table 3](#).

This figure shows the data and command output AC timing diagram.

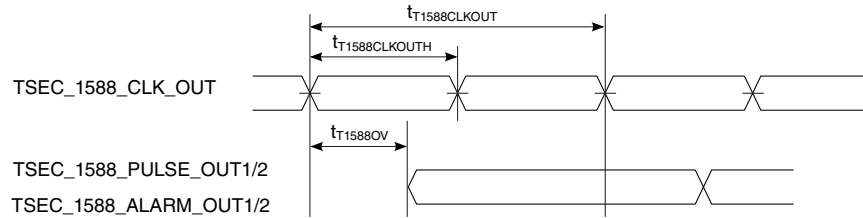

Note: The output delay is counted starting at the rising edge if $t_{T1588CLKOUT}$ is non-inverting. Otherwise, it is counted starting at the falling edge.

Figure 25. IEEE 1588 output AC timing

This figure shows the data and command input AC timing diagram.

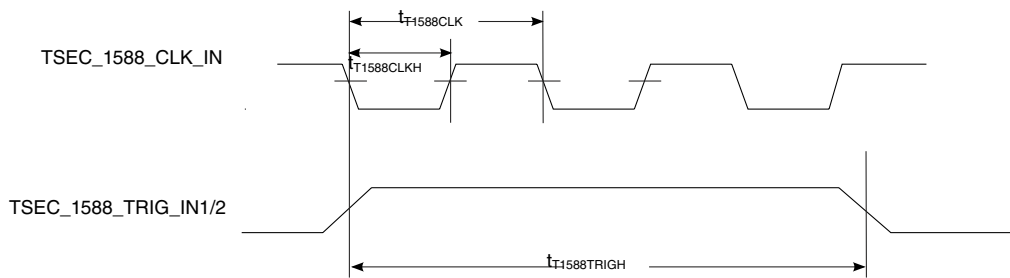

Figure 26. IEEE 1588 input AC timing

3.12 QUICC engine specifications

3.12.1 HDLC interface

This section describes the DC and AC electrical specifications for the high-level data link control (HDLC) interface.

3.12.1.1 HDLC, transparent, and synchronous UART DC electrical characteristics

This table provides the DC electrical characteristics for the HDLC, transparent, and synchronous UART protocols when $DV_{DD} = 3.3 \text{ V}$.

Table 53. HDLC, transparent, and synchronous UART DC electrical characteristics (DV_{DD} = 3.3 V)³

Parameter	Symbol	Min	Max	Unit	Notes
Input high voltage	V _{IH}	0.7 x DV _{DD}	—	V	1
Input low voltage	V _{IL}	—	0.2 x DV _{DD}	V	1
Input current (V _{IN} = 0 V or V _{IN} = DV _{DD})	I _{IN}	—	±50	μA	2
Output high voltage (DV _{DD} = min, I _{OH} = -2 mA)	V _{OH}	2.4	—	V	—
Output low voltage (DV _{DD} = min, I _{OH} = 2 mA)	V _{OL}	—	0.4	V	—

Notes:

1. The min V_{IL} and max V_{IH} values are based on the respective min and max DV_{IN} values found in [Table 3](#).
2. The symbol V_{IN}, in this case, represents the input voltage of the supply referenced in [Table 3](#).
3. For recommended operating conditions, see [Table 3](#).

This table provides the DC electrical characteristics for the HDLC, transparent, and synchronous UART protocols when DV_{DD} = 1.8 V.

Table 54. HDLC, transparent, and synchronous UART DC electrical characteristics (DV_{DD} = 1.8 V)³

Parameter	Symbol	Min	Max	Unit	Notes
Input high voltage	V _{IH}	0.7 x DV _{DD}	—	V	1
Input low voltage	V _{IL}	—	0.2 x DV _{DD}	V	1
Input current (V _{IN} = 0 V or V _{IN} = DV _{DD})	I _{IN}	—	±50	μA	2
Output high voltage (DV _{DD} = min, I _{OH} = -0.5 mA)	V _{OH}	1.35	—	V	—
Output low voltage (DV _{DD} = min, I _{OH} = 0.5 mA)	V _{OL}	—	0.4	V	—

Notes:

1. The min V_{IL} and max V_{IH} values are based on the respective min and max DV_{IN} values found in [Table 3](#).
2. The symbol V_{IN}, in this case, represents the input voltage of the supply referenced in [Table 3](#).
3. For recommended operating conditions, see [Table 3](#).

3.12.1.2 HDLC, transparent, and synchronous UART AC timing specifications

This table provides the input and output AC timing specifications for HDLC and transparent UART protocols.

Table 55. HDLC and transparent AC timing specifications²

Parameter	Symbol	Min	Max	Unit	Notes
Outputs-Internal clock delay	t _{HIKHOV}	0	5.5	ns	1
Outputs-External clock delay	t _{HEKHOV}	1	9.15	ns	1

Table continues on the next page...

Table 55. HDLC and transparent AC timing specifications² (continued)

Parameter	Symbol	Min	Max	Unit	Notes
Outputs-Internal clock high impedance	t_{HIKHOX}	0	5.5	ns	1
Outputs-External clock high impedance	t_{HEKHOX}	1	8	ns	1
Inputs-Internal clock input setup time	t_{HIIVKH}	8	—	ns	—
Inputs-External clock input setup time	t_{HEIVKH}	4	—	ns	—
Inputs-Internal clock input hold time	t_{HIIXKH}	0	—	ns	—
Inputs-External clock input hold time	t_{HEIXKH}	1.1	—	ns	—

Notes:

- Output specifications are measured from the 50% level of the rising edge of CLKIN to the 50% level of the signal. Timings are measured at the pin.
- For recommended operating conditions, see [Table 3](#).

This table provides the input and output AC timing specifications for the synchronous UART protocols.

Table 56. Synchronous UART AC timing specifications²

Parameter	Symbol	Min	Max	Unit	Notes
Outputs-Internal clock delay	t_{HIKHOV}	0	11	ns	1
Outputs-External clock delay	t_{HEKHOV}	1	14	ns	1
Outputs-Internal clock High Impedance	t_{HIKHOX}	0	11	ns	1
Outputs-External clock High Impedance	t_{HEKHOX}	1	14	ns	1
Inputs-Internal clock input setup time	t_{HIIVKH}	10	—	ns	—
Inputs-External clock input setup time	t_{HEIVKH}	8	—	ns	—
Inputs-Internal clock input Hold time	t_{HIIXKH}	0	—	ns	—
Inputs-External clock input hold time	t_{HEIXKH}	1.1	—	ns	—

Notes:

- Output specifications are measured from the 50% level of the rising edge of CLKIN to the 50% level of the signal. Timings are measured at the pin.
- For recommended operating conditions, see [Table 3](#).

This figure shows the AC test load.

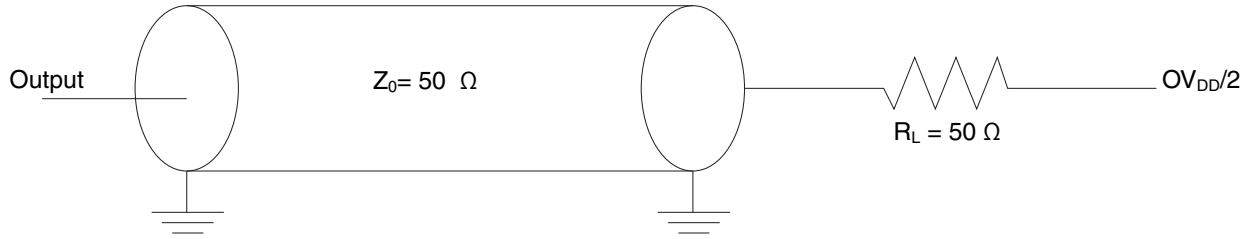
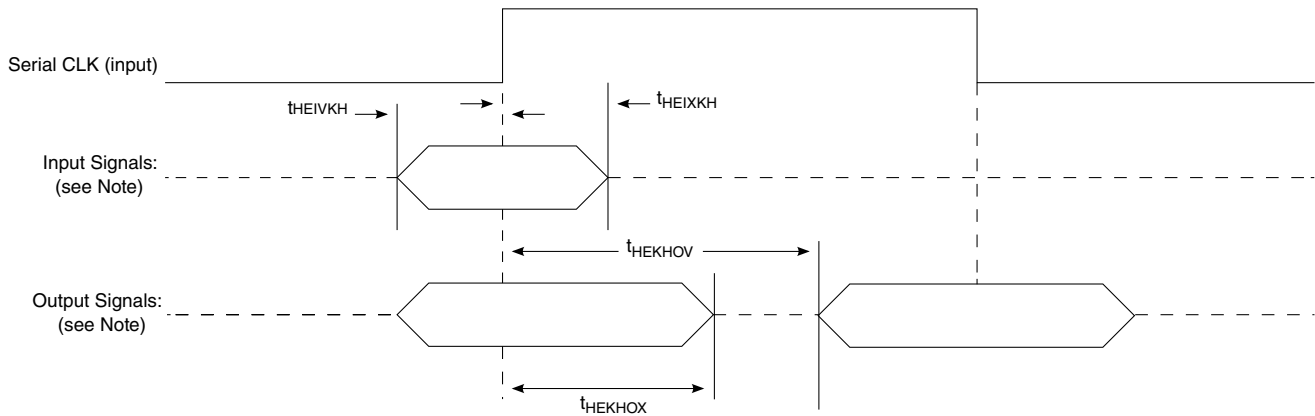

Figure 27. AC test load

These figures represent the AC timing from [Table 55](#) and [Table 56](#). Note that, although the specifications generally reference the rising edge of the clock, these AC timing diagrams also apply when the falling edge is the active edge.

This figure shows the timing with an external clock.



Note: The clock edge is selectable.

Figure 28. AC timing (external clock) diagram

This figure shows the timing with an internal clock.

Electrical characteristics

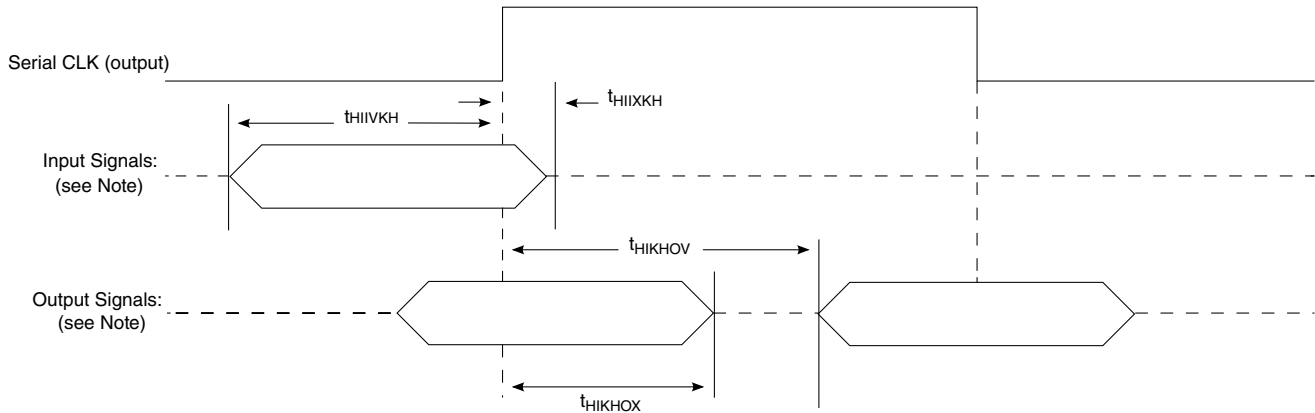

Note: The clock edge is selectable.

Figure 29. AC timing (internal clock) diagram

3.12.2 Time-division-multiplexed and serial interface (TDM/SI)

This section describes the DC and AC electrical specifications for the TDM/SI.

3.12.2.1 TDM/SI DC electrical characteristics

This table provides the TDM/SI DC electrical characteristics when $DV_{DD} = 3.3\text{ V}$.

Table 57. TDM/SI DC electrical characteristics ($DV_{DD} = 3.3\text{ V}$)³

Parameter	Symbol	Min	Max	Unit	Notes
Input high voltage	V_{IH}	$0.7 \times DV_{DD}$	—	V	1
Input low voltage	V_{IL}	—	$0.2 \times DV_{DD}$	V	1
Input current ($V_{IN} = 0\text{ V}$ or $V_{IN} = DV_{DD}$)	I_{IN}	—	± 50	μA	2
Output high voltage ($DV_{DD} = \text{min}$, $I_{OH} = -2\text{ mA}$)	V_{OH}	2.4	—	V	—
Output low voltage ($DV_{DD} = \text{min}$, $I_{OH} = 2\text{ mA}$)	V_{OL}	—	0.4	V	—

Notes:

1. The min V_{IL} and max V_{IH} values are based on the respective min and max BV_{IN} values found in [Table 3](#).
2. The symbol V_{IN} , in this case, represents the input voltage of the supply referenced in [Table 3](#).
3. For recommended operating conditions, see [Table 3](#).

This table provides the TDM/SI DC electrical characteristics when $DV_{DD} = 1.8\text{ V}$.

Table 58. TDM/SI DC electrical characteristics ($DV_{DD} = 1.8\text{ V}$)³

Parameter	Symbol	Min	Max	Unit	Notes
Input high voltage	V_{IH}	$0.7 \times DV_{DD}$	—	V	1

Table continues on the next page...

Table 58. TDM/SI DC electrical characteristics ($DV_{DD} = 1.8\text{ V}$)³ (continued)

Parameter	Symbol	Min	Max	Unit	Notes
Input low voltage	V_{IL}	—	$0.2 \times DV_{DD}$	V	1
Input current ($V_{IN} = 0\text{ V}$ or $V_{IN} = DV_{DD}$)	I_{IN}	—	± 50	μA	2
Output high voltage ($DV_{DD} = \text{min}$, $I_{OH} = -0.5\text{ mA}$)	V_{OH}	1.35	—	V	—
Output low voltage ($DV_{DD} = \text{min}$, $I_{OH} = 0.5\text{ mA}$)	V_{OL}	—	0.4	V	—

Notes:

1. The min V_{IL} and max V_{IH} values are based on the respective min and max BV_{IN} values found in [Table 3](#).
2. The symbol V_{IN} , in this case, represents the input voltage of the supply referenced in [Table 3](#).
3. For recommended operating conditions, see [Table 3](#).

3.12.2.2 TDM/SI AC timing specifications

This table provides the TDM/SI input and output AC timing specifications.

Table 59. TDM/SI AC timing specifications ¹

Parameter	Symbol ¹	Min	Max	Unit
TDM/SI outputs-External clock delay	t_{SEKHOV}	2	11	ns
TDM/SI outputs-External clock High Impedance	t_{SEKHOX}	2	10	ns
TDM/SI inputs-External clock input setup time	t_{SEIVKH}	5	—	ns
TDM/SI inputs-External clock input hold time	t_{SEIXKH}	2	—	ns

Notes:

1. Output specifications are measured from the 50% level of the rising edge of CLKIN to the 50% level of the signal. Timings are measured at the pin.

NOTE

The rise/fall time on QUICC engine block input pins should not exceed 5 ns. This should be enforced especially on clock signals. Rise time refers to signal transitions from 10% to 90% of V_{DD} . Fall time refers to transitions from 90% to 10% of V_{DD} .

This figure shows the AC test load for the TDM/SI.

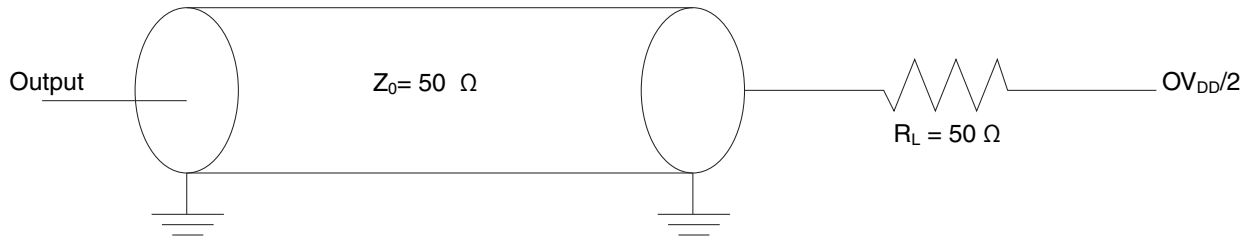
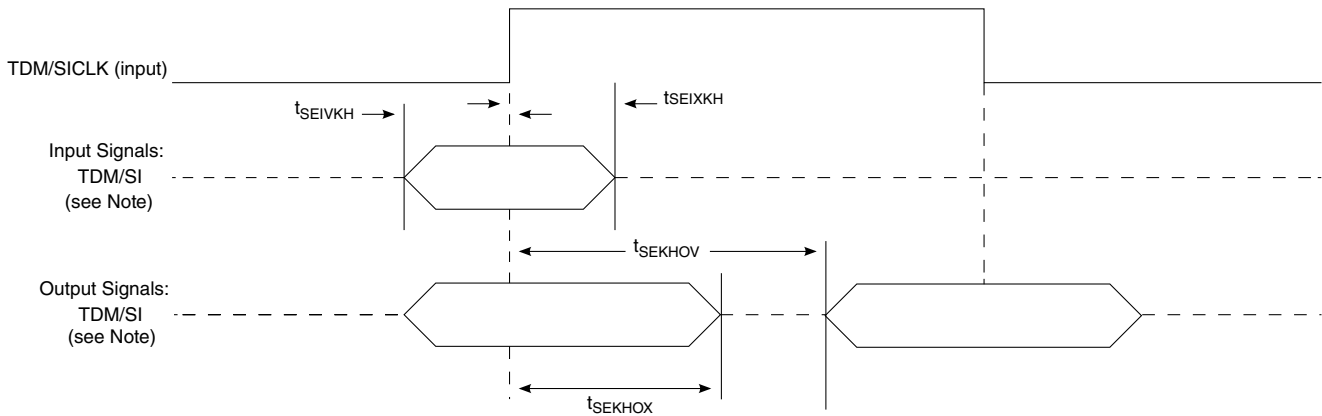

Figure 30. TDM/SI AC test load

This figure represents the AC timing from [Table 59](#). Note that, although the specifications generally reference the rising edge of the clock, these AC timing diagrams also apply when the falling edge is the active edge.

This figure shows the TDM/SI timing with an external clock.



Note: The clock edge is selectable on TDM/SI.

Figure 31. TDM/SI AC timing (external clock) diagram

3.13 USB 2.0 interface

This section describes the AC and DC electrical specifications for the USB 2.0 interface.

3.13.1 USB 2.0 DC electrical characteristics

This table provides the DC electrical characteristics for the USB 2.0 interface when operating at $L V_{DD} = 3.3 \text{ V}$.

Table 60. USB 2.0 DC electrical characteristics (3.3 V)³

Parameter	Symbol	Min	Max	Unit	Notes
Input high voltage	V_{IH}	$0.7 \times LV_{DD}$	—	V	1
Input low voltage	V_{IL}	—	$0.2 \times LV_{DD}$	V	1
Input current ($V_{IN} = 0$ V or $V_{IN} = LV_{DD}$)	I_{IN}	—	± 50	μ A	2
Output high voltage ($LV_{DD} = \text{min}$, $I_{OH} = -2$ mA)	V_{OH}	2.4	—	V	—
Output low voltage ($LV_{DD} = \text{min}$, $I_{OL} = 2$ mA)	V_{OL}	—	0.4	V	—

Notes:

1. The min V_{IL} and max V_{IH} values are based on the respective min and max LV_{IN} values found in [Table 3](#).
2. The symbol V_{IN} , in this case, represents the LV_{IN} symbol referenced in [Table 3](#).
3. For recommended operating conditions, see [Table 3](#).

This table provides the DC electrical characteristics for the USB 2.0 interface when operating at $LV_{DD} = 2.5$ V.

Table 61. USB 2.0 DC electrical characteristics (2.5 V)³

Parameter	Symbol	Min	Max	Unit	Notes
Input high voltage	V_{IH}	$0.7 \times LV_{DD}$	—	V	1
Input low voltage	V_{IL}	—	$0.2 \times LV_{DD}$	V	1
Input current ($V_{IN} = 0$ V or $V_{IN} = LV_{DD}/L1V_{DD}$)	I_{IN}	—	± 50	μ A	2
Output high voltage ($LV_{DD}/L1V_{DD} = \text{min}$, $I_{OH} = -1$ mA)	V_{OH}	2.0	—	V	—
Output low voltage ($LV_{DD}/L1V_{DD} = \text{min}$, $I_{OL} = 1$ mA)	V_{OL}	—	0.4	V	—

Notes:

1. The min V_{IL} and max V_{IH} values are based on the respective min and max $LV_{IN}/L1V_{IN}$ values found in [Table 3](#).
2. The symbol V_{IN} , in this case, represents the $LV_{IN}/L1V_{IN}$ symbol referenced in [Table 3](#).
3. For recommended operating conditions, see [Table 3](#).

This table provides the DC electrical characteristics for the USB 2.0 interface when operating at $LV_{DD} = 1.8$ V.

Table 62. USB 2.0 DC electrical characteristics (1.8 V)³

Parameter	Symbol	Min	Max	Unit	Notes
Input high voltage	V_{IH}	$0.7 \times LV_{DD}$	—	V	1
Input low voltage	V_{IL}	—	$0.2 \times LV_{DD}$	V	1
Input current ($V_{IN} = 0$ V or $V_{IN} = LV_{DD}$)	I_{IN}	—	± 50	μ A	2

Table continues on the next page...

Table 62. USB 2.0 DC electrical characteristics (1.8 V)³ (continued)

Parameter	Symbol	Min	Max	Unit	Notes
Output high voltage ($V_{DD} = \min$, $I_{OH} = -0.5 \text{ mA}$)	V_{OH}	1.35	—	V	—
Output low voltage ($V_{DD} = \min$, $I_{OL} = 0.5 \text{ mA}$)	V_{OL}	—	0.4	V	—

Notes:

- The min V_{IL} and max V_{IH} values are based on the respective min and max V_{IN} values found in [Table 3](#).
- The symbol V_{IN} , in this case, represents the V_{IN} symbol referenced in [Table 3](#).
- For recommended operating conditions, see [Table 3](#).

3.13.2 USB 2.0 AC timing specifications

3.13.2.1 USB 2.0 AC timing specifications for ULPI mode

This table provides the general timing parameters of the USB 2.0 interface for ULPI mode.

Table 63. USB 2.0 general timing parameters (ULPI mode only)^{1, 6, 7}

Parameter	Symbol _{1, 6}	Min	Max	Unit	Notes
USB clock cycle time	t_{USCK}	15	—	ns	2, 3, 4, 5
Input setup to USB clock--all inputs	t_{USIVKH}	4	—	ns	2, 3, 4, 5
Input hold to USB clock--all inputs	t_{USIXKH}	1	—	ns	2, 3, 4, 5
USB clock to output valid--all outputs	t_{USKHOV}	—	7	ns	2, 3, 4, 5
Output hold from USB clock--all outputs	t_{USKHOX}	2	—	ns	2, 3, 4, 5

Notes:

- The symbols for timing specifications follow these patterns: $t_{(\text{First two letters of functional block})(\text{signal})(\text{state})(\text{reference})(\text{state})}$ for inputs and $t_{(\text{First two letters of functional block})(\text{reference})(\text{state})(\text{signal})(\text{state})}$ for outputs. For example, t_{USIXKH} symbolizes USB timing (US) for the input (I) to go invalid (X) with respect of the time the USB clock reference (K) goes high (H). Also, t_{USKHOX} symbolizes USB timing (US) for the USB clock reference (K) to go high (H) with respect to the output (O) going invalid (X) or output hold time.
- All timings are in reference to the USB 2.0 clock.
- All signals are measured from $OV_{DD}/2$ of the rising edge of the USB 2.0 clock to $0.4 \times OV_{DD}$ of the signal in question for 3.3 V signaling levels.
- Input timings are measured at the pin.
- For active/float timing measurements, the high impedance or off state is defined to be when the total current delivered through the component pin is less than or equal to that of the leakage current specification.
- When switching the data pins from outputs to inputs using the $USBn_DIR$ pin, the output timings will be violated on that cycle because the output buffers are tristated asynchronously. This should not be a problem, because the PHY should not be functionally looking at these signals on that cycle as per ULPI specifications.
- For recommended operating conditions, see [Table 3](#).

This figure provides the AC test load for the USB 2.0.

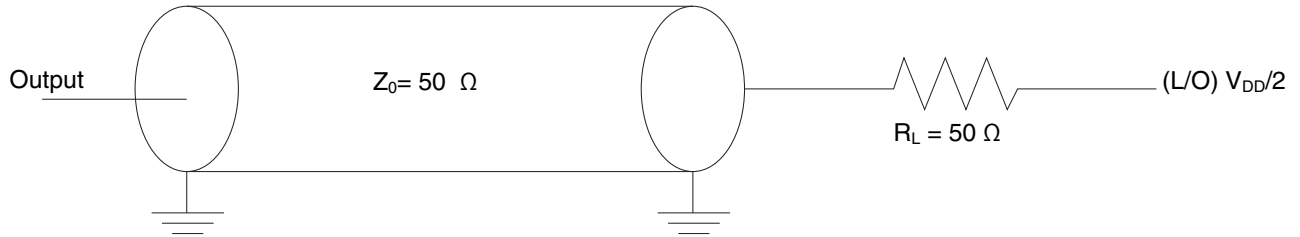

Figure 32. USB 2.0 AC test load

This figure provides the AC signals for the USB 2.0 interface for ULPI mode.

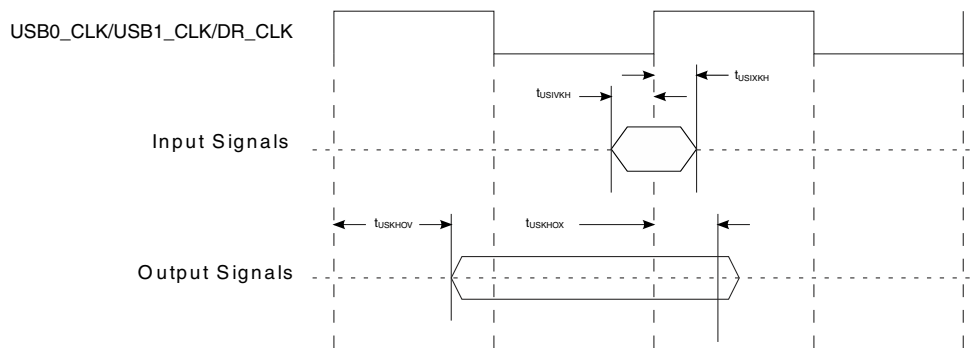

Figure 33. USB 2.0 ULPI mode AC Signals

This table provides the USB 2.0 clock input (USB_CLK_IN) AC timing specifications.

Table 64. USB_CLK_IN AC timing specifications

Parameter	Condition	Symbol	Min	Typ	Max	Unit
Frequency range	Steady state	$f_{\text{USB_CLK_IN}}$	59.97	60	60.03	MHz
Clock frequency tolerance	—	$t_{\text{CLK_TOL}}$	- 0.05	0	0.05	%
Reference clock duty cycle	Measured at rising edge and/or falling edge at $LV_{\text{DD}}/2$	$t_{\text{CLK_DUTY}}$	40	50	60	%
Total input jitter time interval error	Peak-to-peak value measured with a second-order, high-pass filter of 500-kHz bandwidth	$t_{\text{CLK_PJ}}$	—	—	200	ps

3.14 USB 3.0 interface

This section describes the DC and AC electrical specifications for the USB 3.0 interface.

3.14.1 USB 3.0 PHY transceiver supply DC voltage

This table provides the DC electrical characteristics for the USB 3.0 interface when operating at $USB_HV_{DD} = 3.3\text{ V}$.

Table 65. USB 3.0 PHY transceiver supply DC voltage ($USB_HV_{DD} = 3.3\text{ V}$)²

Parameter	Symbol	Min	Max	Unit	Notes
Input high voltage	V_{IH}	2.0	—	V	1
Input low voltage	V_{IL}	—	0.8	V	1
Output high voltage ($USB_HV_{DD} = \text{min}$, $I_{OH} = -2\text{ mA}$)	V_{OH}	2.8	—	V	—
Output low voltage ($USB_HV_{DD} = \text{min}$, $I_{OL} = 2\text{ mA}$)	V_{OL}	—	0.3	V	—

Notes:

1. The min V_{IL} and max V_{IH} values are based on the respective min and max USB_HV_{IN} values found in [Table 3](#).
2. For recommended operating conditions, see [Table 3](#).

3.14.2 USB 3.0 DC electrical characteristics

This table provides the USB 3.0 transmitter DC electrical characteristics at package pins.

Table 66. USB 3.0 transmitter DC electrical characteristics¹

Characteristic	Symbol	Min	Nom	Max	Unit
Differential output voltage	$V_{tx\text{-diff-pp}}$	800	1000	1200	mV_{p-p}
Low power differential output voltage	$V_{tx\text{-diff-pp-low}}$	400	—	1200	mV_{p-p}
Tx de-emphasis	$V_{tx\text{-de-ratio}}$	3	—	4	dB
Differential impedance	Z_{diffTX}	72	100	120	Ohm
Tx common mode impedance	R_{TX-DC}	18	—	30	Ohm
Absolute DC common mode voltage between U1 and U0	$T_{TX-CM-DC-ACTIVEIDLE-DELTA}$	—	—	200	mV
DC electrical idle differential output voltage	$V_{TX-IDLE-DIFF-DC}$	0	—	10	mV

Note:

1. For recommended operating conditions, see [Table 3](#).

This table provides the USB 3.0 receiver DC electrical characteristics at the Rx package pins.

Table 67. USB 3.0 receiver DC electrical characteristics

Characteristic	Symbol	Min	Nom	Max	Unit	Notes
Differential Rx input impedance	R _{RX-DIFF-DC}	72	100	120	Ohm	—
Receiver DC common mode impedance	R _{RX-DC}	18	—	30	Ohm	—
DC input CM input impedance for V > 0 during reset or power down	ZRX-HIGH-IMP-DC	25 K	—	—	Ohm	—
LFPS detect threshold	VRX-IDLE-DET-DC-DIFF _{pp}	100	—	300	mV	1

Note:

1. Below the minimum is noise. Must wake up above the maximum.

3.14.3 USB 3.0 AC timing specifications

This table provides the USB 3.0 transmitter AC timing specifications at package pins.

Table 68. USB 3.0 transmitter AC timing specifications¹

Parameter	Symbol	Min	Nom	Max	Unit	Notes
Speed	—	—	5.0	—	Gb/s	—
Transmitter eye	t _{TX-Eye}	0.625	—	—	UI	—
Unit interval	UI	199.94	—	200.06	ps	2
AC coupling capacitor	AC coupling capacitor	75	—	200	nF	—

Note:

1. For recommended operating conditions, see [Table 3](#).

2. UI does not account for SSC-caused variations.

This table provides the USB 3.0 receiver AC timing specifications at Rx package pins.

Table 69. USB 3.0 receiver AC timing specifications¹

Parameter	Symbol	Min	Nom	Max	Unit	Notes
Unit interval	UI	199.94	—	200.06	ps	2

Notes:

1. For recommended operating conditions, see [Table 3](#).

2. UI does not account for SSC-caused variations.

3.14.4 USB 3.0 reference clock requirements

This table summarizes the requirements of the reference clock provided to the USB 3.0 SSPHY. There are two options for the reference clock of USB PHY: SYSCLK or DIFF_SYSCLK/DIFF_SYSCLK_B. The following table provides the additional requirements when SYSCLK or DIFF_SYSCLK/DIFF_SYSCLK_B is used as USB REFCLK. This table can also be used for 100 MHz reference clock requirements.

Table 70. Reference clock requirements

Parameter	Symbol	Min	Typ	Max	Unit	Notes
Reference clock frequency offset	FREF_OFFSET	-300	—	300	ppm	—
Reference clock random jitter (RMS)	RMSJREF_CLK	—	—	3	ps	1, 2
Reference clock deterministic jitter	DJREF_CLK	—	—	150	ps	3
Duty cycle	DCREF_CLK	40	—	60	%	—

Notes:

- 1.5 MHz to Nyquist frequency. For example, for 100 MHz reference clock, the Nyquist frequency is 50 MHz.
- The peak-to-peak Rj specification is calculated as 14.069 times the RMS Rj for 10-12 BER.
- DJ across all frequencies.

3.14.5 USB 3.0 LFPS specifications

This table provides the key LFPS electrical specifications at the transmitter.

Table 71. LFPS electrical specifications at the transmitter

Parameter	Symbol	Min	Typ	Max	Unit	Notes
Period	tPeriod	20	—	100	ns	—
Peak-to-peak differential amplitude	V _{TX-DIFF-PP-LFPS}	800	—	1200	mV	—
Low-power peak-to-peak differential amplitude	V _{TX-DIFF-PP-LFPS-LP}	400	—	600	mV	—
Rise/fall time	t _{RiseFall2080}	—	—	4	ns	1
Duty cycle	Duty cycle	40	—	60	%	1

Note:

1. Measured at compliance TP1. See [Figure 34](#) for details.

This figure shows the Tx normative setup with reference channel as per USB 3.0 specifications.

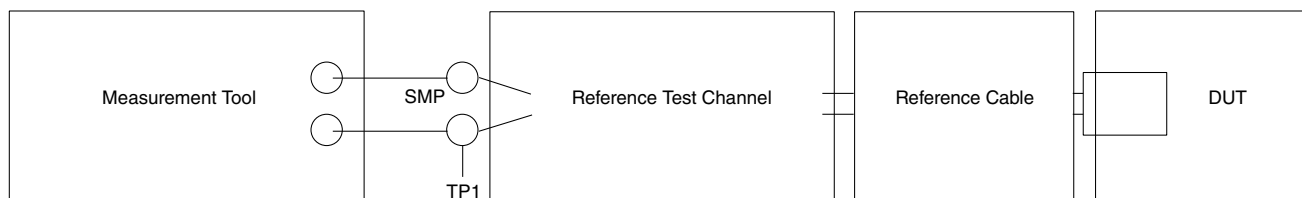

Figure 34. Tx normative setup

3.15 Integrated flash controller (IFC)

This section describes the DC and AC electrical specifications for the integrated flash controller (IFC).

3.15.1 IFC DC electrical characteristics

This table provides the DC electrical characteristics for the IFC when operating at $BV_{DD} = 3.3\text{ V}$.

Table 72. IFC DC electrical characteristics (3.3 V)³

Parameter	Symbol	Min	Max	Unit	Notes
Input high voltage	V_{IH}	$0.7 \times BV_{DD}$	—	V	1
Input low voltage	V_{IL}	—	$0.2 \times BV_{DD}$	V	1
Input current ($V_{IN} = 0\text{ V}$ or $V_{IN} = BV_{DD}$)	I_{IN}	—	± 50	μA	2
Output high voltage ($BV_{DD} = \text{min}$, $I_{OH} = -2\text{ mA}$)	V_{OH}	2.4	—	V	—
Output low voltage ($BV_{DD} = \text{min}$, $I_{OL} = 2\text{ mA}$)	V_{OL}	—	0.4	V	—

Notes:

1. The min V_{IL} and max V_{IH} values are based on the respective min and max BV_{IN} values found in [Table 3](#).
2. The symbol V_{IN} , in this case, represents the BV_{IN} symbol referenced in [Table 3](#).
3. For recommended operating conditions, see [Table 3](#).

This table provides the DC electrical characteristics for the IFC when operating at $BV_{DD} = 1.8\text{ V}$.

Table 73. IFC DC electrical characteristics (1.8 V)³

Parameter	Symbol	Min	Max	Unit	Note
Input high voltage	V_{IH}	$0.7 \times BV_{DD}$	—	V	1
Input low voltage	V_{IL}	—	$0.2 \times BV_{DD}$	V	1

Table continues on the next page...

Table 73. IFC DC electrical characteristics (1.8 V)³ (continued)

Parameter	Symbol	Min	Max	Unit	Note
Input current ($V_{IN} = 0\text{ V}$ or $V_{IN} = BV_{DD}$)	I_{IN}	—	± 50	μA	2
Output high voltage ($BV_{DD} = \text{min}$, $I_{OH} = -0.5\text{ mA}$)	V_{OH}	1.35	—	V	—
Output low voltage ($BV_{DD} = \text{min}$, $I_{OL} = 0.5\text{ mA}$)	V_{OL}	—	0.4	V	—

Notes:

1. The min V_{IL} and max V_{IH} values are based on the respective min and max BV_{IN} values found in [Table 3](#).
2. The symbol V_{IN} , in this case, represents the BV_{IN} symbol referenced in [Table 3](#).
3. For recommended operating conditions, see [Table 3](#).

3.15.2 IFC AC timing specifications

This section describes the AC timing specifications for the IFC.

3.15.2.1 Test condition

This figure shows the AC test load for the IFC.

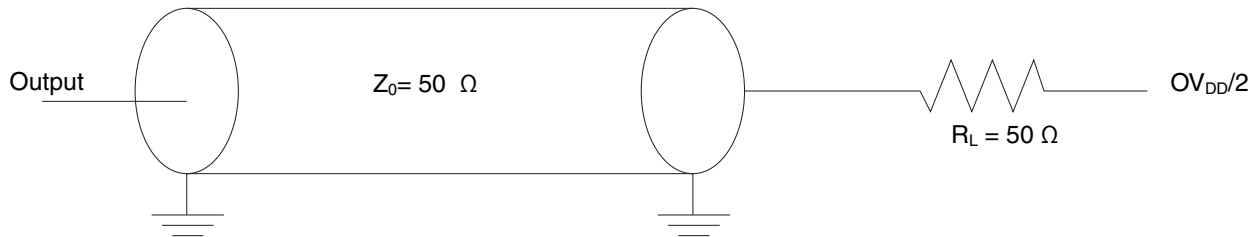

Figure 35. IFC AC test load

3.15.2.2 IFC input AC timing specifications

This table provides the input AC timing specifications of the IFC-GPCM and IFC-GASIC interfaces.

Table 74. IFC input timing specifications for GPCM and GASIC mode ($BV_{DD} = 1.8/3.3\text{ V}$)

Parameter	Symbol	Min	Max	Unit	Notes
Input setup	t_{BIVKH1}	4	—	ns	—

Table continues on the next page...

Table 74. IFC input timing specifications for GPCM and GASIC mode ($BV_{DD} = 1.8/3.3\text{ V}$) (continued)

Parameter	Symbol	Min	Max	Unit	Notes
Input hold	t_{BIXKH1}	1	—	ns	—

This figure shows the input AC timing diagram for the IFC-GPCM and IFC-GASIC interfaces.

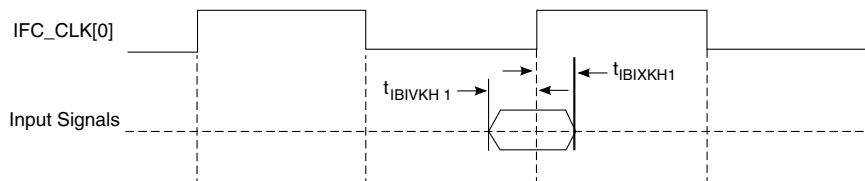
**Figure 36. IFC-GPCM and IFC-GASIC input AC timings**

This table provides the input timing specifications of the IFC-NOR interface.

Table 75. IFC input timing specifications for NOR mode ($BV_{DD} = 1.8/3.3\text{ V}$)²

Parameter	Symbol	Min	Max	Unit	Notes
Input setup	t_{BIVKH2}	$(2 \times t_{IP_CLK}) + 2$	—	ns	1
Input hold	t_{BIXKH2}	$1 \times t_{IP_CLK}$	—	ns	1

Notes:

- t_{IP_CLK} is the period of ip clock (not the IFC_CLK) on which IFC is running.
- For recommended operating conditions, see [Table 3](#).

This figure shows the AC input timing diagram for input signals of the IFC-NOR interface. Here, TRAD is a programmable delay parameter. Refer to the IFC section of LS1020A QorIQ Advanced Multicore Processor Reference Manual for more information.

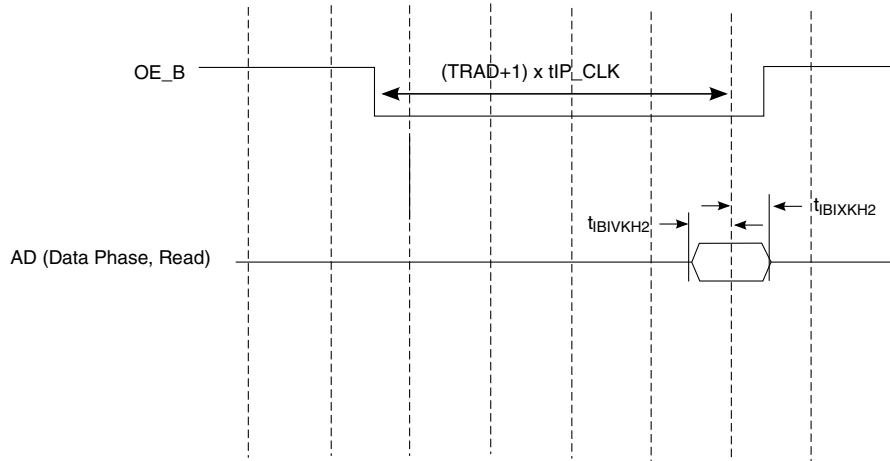

Note: IP_CLK is the internal clock on which IFC is running. It is not available on interface pins.

Figure 37. IFC-NOR interface input AC timings

This table provides the input timing specifications of the IFC-NAND interface.

Table 76. IFC input timing specifications for NAND mode (BV_{DD} = 1.8/3.3 V)²

Parameter	Symbol	Min	Max	Unit	Notes
Input setup	t _{BIVKH3}	(2 x t _{IP_CLK}) + 2	—	ns	1
Input hold	t _{BIXKH3}	1 x t _{IP_CLK}	—	ns	1
IFC_RB_B pulse width	t _{BCH}	2	—	t _{IP_CLK}	1

Notes:

- t_{IP_CLK} is the period of ip clock on which IFC is running.
- For recommended operating conditions, see [Table 3](#).

This figure shows the AC input timing diagram for input signals of the IFC-NAND interface. Here, TRAD is a programmable delay parameter. Refer to the IFC section of LS1020A QorIQ Advanced Multicore Processor Reference Manual for more information.

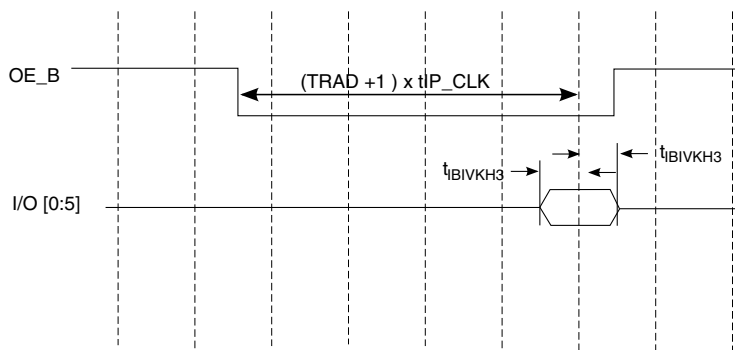

Note: tIP_CLK is the period of IP clock (not the IFC_CLK) on which IFC is running.

Figure 38. IFC-NAND interface input AC timings

3.15.2.3 IFC output AC timing specifications

This table provides the output AC timing specifications of the IFC-GPCM and IFC-GASIC interface.

Table 77. IFC-GPCM and IFC-GASIC interface output timing specifications ($BV_{DD} = 1.8/3.3$ V)²

Parameter	Symbol	Min	Max	Unit	Notes
IFC_CLK cycle time	t_{IBK}	10	—	ns	—
IFC_CLK duty cycle	t_{IBKH}/t_{IBK}	45	55	%	—
Output delay	$t_{IBKLOV1}$	—	1.5	ns	—
Output hold	t_{IBKLOX}	—	-2	ns	1
IFC_CLK[0] to IFC_CLK[m] skew	$t_{IBKSKEW}$	0	± 150	ps	—

Notes:

- Output hold is negative. This means that output transition happens earlier than the falling edge of IFC_CLK.
- For recommended operating conditions, see [Table 3](#).

This figure shows the output AC timing diagram for the IFC-GPCM and IFC-GASIC interfaces.

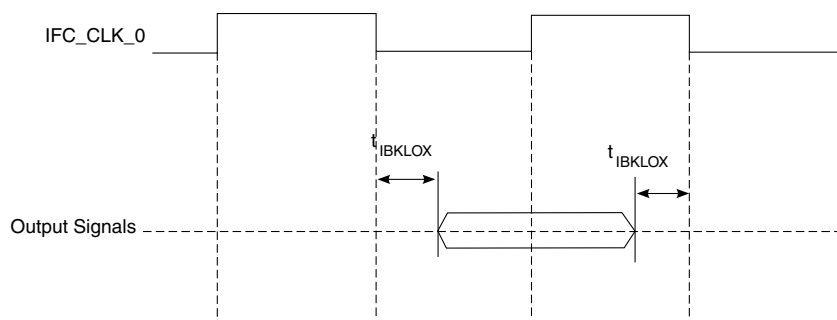

Figure 39. IFC-GPCM and IFC-GASIC signals

This table provides the output AC timing specifications of the IFC-NOR interface.

Table 78. IFC-NOR interface output timing specifications ($BV_{DD} = 1.8/3.3$ V)

Parameter	Symbol	Min	Max	Unit	Notes
Output delay	$t_{IBKLOV2}$	—	± 1.5	ns	1

Notes:

Table 78. IFC-NOR interface output timing specifications (BV_{DD} = 1.8/3.3 V)

Parameter	Symbol	Min	Max	Unit	Notes
1. This effectively means that a signal change may appear anywhere within $\pm t_{IBKLOV2}$ (max) duration, from the point where it is expected to change. 2. For recommended operating conditions, see Table 3 .					

This figure shows the AC timing diagram for output signals of the IFC-NOR interface.

The timing specifications have been illustrated here by taking timings between two signals, CS_B and OE_B, as an example. OE_B is intended to change TACO (a programmable delay) time after CS_B. Refer to the IFC section of LS1020A QorIQ Advanced Multicore Processor Reference Manual for more information.

Because of skew between the signals, OE_B may change anywhere within the time window $t_{IBKLOV2}$ (min) and $t_{IBKLOV2}$ (max). This concept applies to other output signals of the IFC-NOR interface, as well.

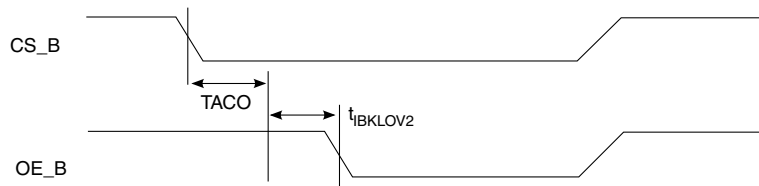

Figure 40. IFC-NOR Interface output AC timings

This table provides the output AC timing specifications of the IFC-NAND interface.

Table 79. IFC-NAND interface output timing specifications (BV_{DD} = 1.8/3.3 V)²

Parameter	Symbol	Min	Max	Unit	Notes
Output delay	$t_{IBKLOV3}$	—	+/-1.5	ns	1
Notes: 1. This effectively means that a signal change may appear anywhere within $t_{IBKLOV3}$ (min) to $t_{IBKLOV3}$ (max) duration, from the point where it is expected to change. 2. For recommended operating conditions, see Table 3 .					

This figure shows the AC timing diagram for output signals of the IFC-NAND interface.

The timing specifications have been illustrated here by taking timings between two signals, CS_B and CLE, as an example. CLE is intended to change TCCST (a programmable delay) time after CS_B. Refer to the IFC section of LS1020A QorIQ Advanced Multicore Processor Reference Manual for more information.

Because of skew between the signals, CLE may change anywhere within the time window $t_{IBKLOV3}$ (min) and $t_{IBKLOV3}$ (max). This concept applies to other output signals of the IFC-NAND interface, as well.

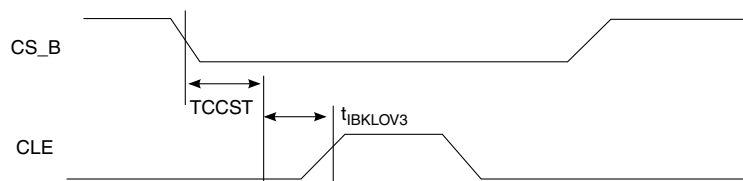

Figure 41. IFC-NAND interface output AC timings

3.15.3 IFC NAND Source Synchronous interface AC timing specifications

This table describes the AC timing specifications of the IFC-NAND Source Synchronous interface.

Table 80. IFC-NAND Source Synchronous interface AC timing specifications ($BV_{DD} = 1.8/3.3$ V)⁴

Parameter	Symbol	I/O	Min	Max	Unit	Notes
Command/address DQ hold time	t_{CAH}	O	2.5	—	ns	—
CLE and ALE hold time	t_{CALH}	O	2.5	—	ns	—
CLE and ALE setup time	t_{CALS}	O	2.5	—	ns	—
Command/address DQ setup time	t_{CAS}	O	2.5	—	ns	—
CE# hold time	t_{CH}	O	2.5	—	ns	—
Data DQ setup time	t_{DS}	O	1	—	ns	—
Data DQ hold time	t_{DH}	O	1	—	ns	—
Average clock cycle time (reference signal pin name IFC_NDDDR_CLK)	$t_{CK(avg)}$ or t_{CK}	O	13.33	—	ns	1
Absolute clock period	$t_{CK(abs)}$	O	$t_{CK(avg)} - 0.5$	$t_{CK(avg)} + 0.5$	ns	—
Clock cycle high	$t_{CKH(abs)}$	O	0.44	0.56	t_{CK}	2
Clock cycle low	$t_{CKL(abs)}$	O	0.44	0.56	t_{CK}	—
DQS output high pulse width	t_{DQSH}	O	0.43	0.57	t_{CK}	3
DQS output low pulse width	t_{DQSL}	O	0.43	0.57	t_{CK}	3
DQS-DQ skew, DQS to last DQ valid, per access	t_{DQSQ}	I	—	1ns=1.8V 570ps=3.3V	—	5

Table continues on the next page...

Table 80. IFC-NAND Source Synchronous interface AC timing specifications ($BV_{DD} = 1.8/3.3$ V)⁴ (continued)

Parameter	Symbol	I/O	Min	Max	Unit	Notes
Data output to first DQS latching transition	t_{DQSS}	O	$(0.75 * t_{CK}) + 150ps$	$(1.25 * t_{CK}) - 150ps$	t_{CK}	—
DQS cycle time	t_{DSC}	O	10	—	ns	—
DQS falling edge to CLK rising – hold time	t_{DSH}	O	$(0.2 * t_{CK}) + 150ps$	—	t_{CK}	—
DQS falling edge to CLK rising – setup time	t_{DSS}	O	0.3	—	t_{CK}	—
Input data valid window	t_{DVW}	I	2.1ns=1.8V 2.95ns=3.3V	—	ns	5
Half-clock period	t_{HP}	O	4.4	—	ns	—
The deviation of a given $t_{CK}(abs)$ from $t_{CK}(avg)$	$t_{JIT}(per)$	O	-0.5	0.5	ns	—
DQ-DQS hold, DQS to first DQ to go non-valid, per access	t_{QH}	I	4.64	—	ns	—

Notes:

- $t_{CK}(avg)$ is the average clock period over any consecutive 200 cycle window.
- $t_{CKH}(abs)$ and $t_{CKL}(abs)$ include static off set and duty cycle jitter.
- t_{DQSL} and t_{DQSH} are relative to t_{CK} when CLK is running . If CLK is stopped during data input, then t_{DQSL} and t_{DQSH} are relative to t_{DSC} .
- For recommended operating conditions, see [Table 3](#)
- These AC parameters do not meet ONFI standard. The board designer needs to take into account trace length for these signals to meet the timing requirement.

These figures show the AC timing diagram for IFC-NAND source synchronous interface.

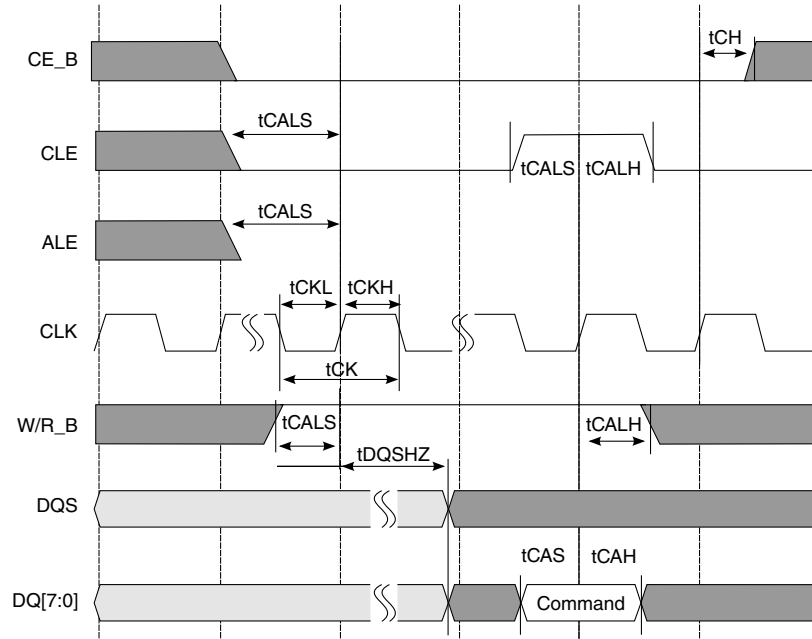

Figure 42. Command cycle

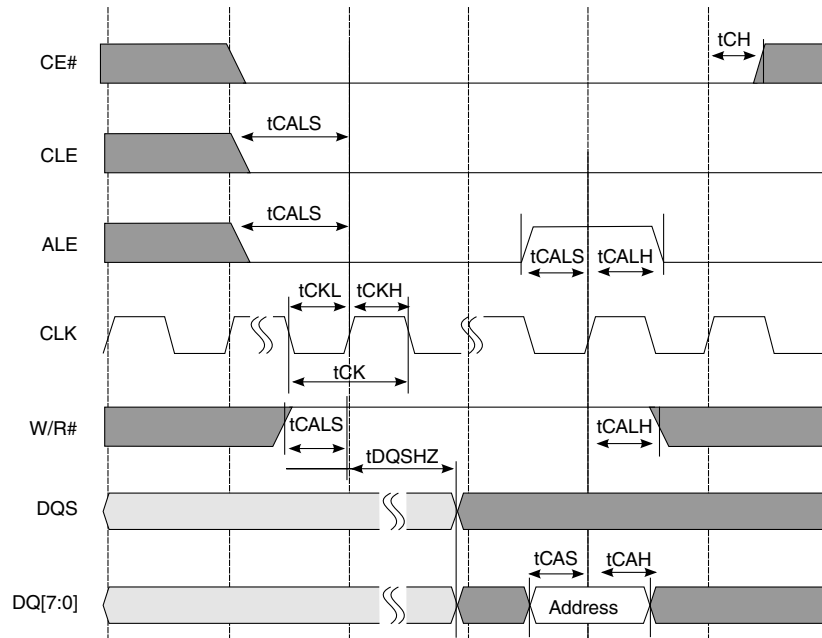

Figure 43. Address cycle

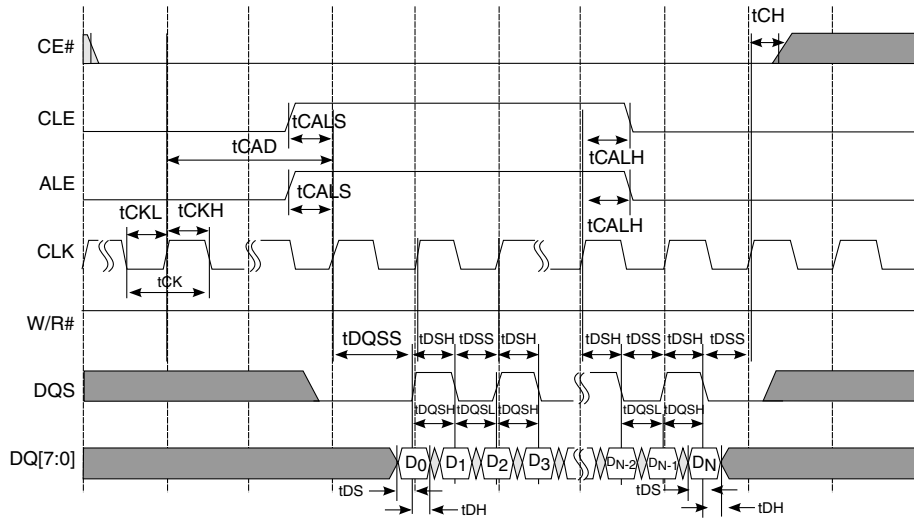

Figure 44. Write cycle

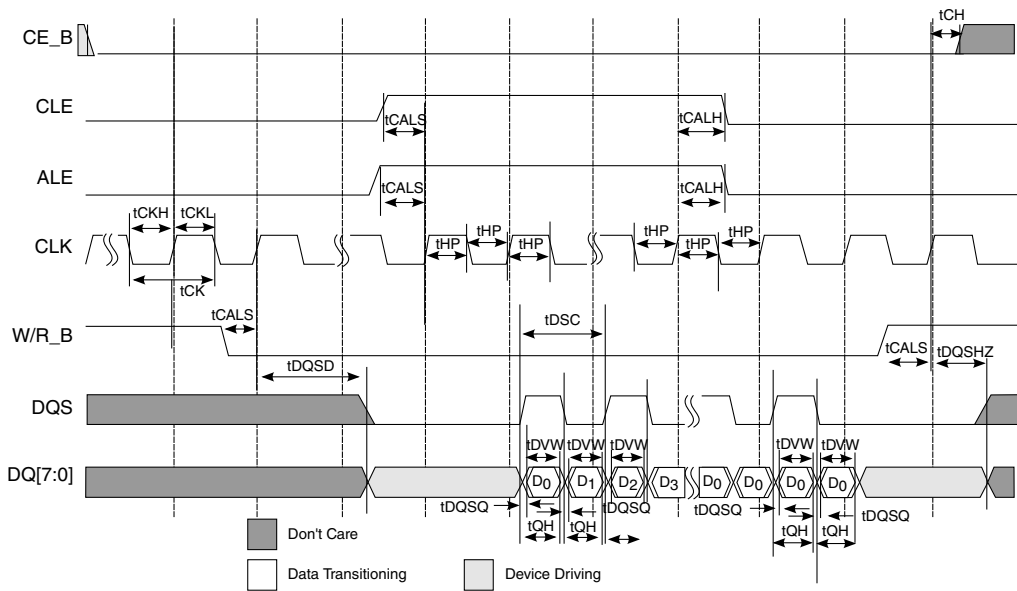

Figure 45. Read cycle

3.16 LPUART interface

This section describes the DC and AC electrical specifications for the LPUART interface.

3.16.1 LPUART DC electrical characteristics

This table provides the DC electrical characteristics for the LPUART interface when operating at $DV_{DD} = 3.3\text{ V}$.

Table 81. LPUART DC electrical characteristics (3.3 V)²

Parameter	Symbol	Min	Max	Unit	Notes
Input high voltage	V_{IH}	$0.7 \times DV_{DD}$	—	V	1
Input low voltage	V_{IL}	—	$0.2 \times DV_{DD}$	V	1
Input current ($DV_{IN} = 0\text{ V}$ or $DV_{IN} = DV_{DD}$)	I_{IN}	—	± 50	μA	—
Output high voltage ($I_{OH} = -2.0\text{ mA}$)	V_{OH}	2.4	—	V	—
Output low voltage ($I_{OL} = 2.0\text{ mA}$)	V_{OL}	—	0.4	V	—

Notes:

1. The min V_{IL} and max V_{IH} values are based on the min and max DV_{DD} respective values found in [Table 3](#).
2. For recommended operating conditions, see [Table 3](#).

This table provides the DC electrical characteristics for the LPUART interface when operating at $DV_{DD} = 1.8\text{ V}$.

Table 82. LPUART DC electrical characteristics (1.8 V)³

Parameter	Symbol	Min	Max	Unit	Notes
Input high voltage	V_{IH}	$0.7 \times DV_{DD}$	—	V	1
Input low voltage	V_{IL}	—	$0.2 \times DV_{DD}$	V	1
Input current ($DV_{IN} = 0\text{ V}$ or $DV_{IN} = DV_{DD}$)	I_{IN}	—	± 50	μA	2
Output high voltage ($DV_{DD} = \text{min}$, $I_{OH} = -0.5\text{ mA}$)	V_{OH}	1.35	—	V	—
Output low voltage ($DV_{DD} = \text{min}$, $I_{OL} = 0.5\text{ mA}$)	V_{OL}	—	0.4	V	—

Notes:

1. The min V_{IL} and max V_{IH} values are based on the min and max DV_{DD} respective values found in [Table 3](#).
2. The symbol DV_{IN} represents the input voltage of the supply referenced in [Table 3](#).
3. For recommended operating conditions, see [Table 3](#).

3.16.2 LPUART AC timing specifications

This table provides the AC timing specifications for the LPUART interface.

Table 83. LPUART AC timing specifications

Parameter	Value	Unit	Notes
Minimum baud rate	$f_{PLAT}/(2 \times 32 \times 8192)$	baud	1, 3, 4

Table continues on the next page...

**Table 83. LPUART AC timing specifications
(continued)**

Parameter	Value	Unit	Notes
Maximum baud rate	$f_{\text{PLAT}}/(2 \times 4)$	baud	1, 2, 4
Notes:			
1. f_{PLAT} refers to the internal platform clock.			
2. The actual attainable baud rate is limited by the latency of interrupt processing.			
3. Every bit can be over sampled with a sample clock rate of 8 and 64 times (software configurable) and each bit is the majority of the values sampled at the sample rate divided by two, (sample rate/2)+1 and (sample rate/2)+2.			
4. The 1-to-0 transition during a data word can cause a resynchronization of the sample point.			

3.17 Flextimer interface

This section describes the DC and AC electrical characteristics for the Flextimer interface. There are Flextimer pins on various power supplies in this device.

3.17.1 Flextimer DC electrical characteristics

This table provides the DC electrical characteristics for Flextimer pins operating at $L/L1/D/BV_{\text{DD}} = 3.3 \text{ V}$.

Table 84. Flextimer DC electrical characteristics (3.3 V)³

Parameter	Symbol	Min	Max	Unit	Notes
Input high voltage	V_{IH}	$0.7 \times nV_{\text{DD}}$	—	V	1
Input low voltage	V_{IL}	—	$0.2 \times nV_{\text{DD}}$	V	1
Input current ($V_{\text{IN}} = 0 \text{ V}$ or $V_{\text{IN}} = L/L1/D/BV_{\text{DD}}$)	I_{IN}	—	± 50	μA	2
Output high voltage ($L/L1/D/BV_{\text{DD}} = \text{min}$, $I_{\text{OH}} = -2 \text{ mA}$)	V_{OH}	2.4	—	V	—
Output low voltage ($L/L1/D/BV_{\text{DD}} = \text{min}$, $I_{\text{OL}} = 2 \text{ mA}$)	V_{OL}	—	0.4	V	—
Notes:					
1. The min V_{IL} and max V_{IH} values are based on the respective min and max $L/L1/D/BV_{\text{IN}}$ values found in Table 3 .					
2. The symbol V_{IN} , in this case, represents the $L/L1/D/BV_{\text{IN}}$ symbol referenced in Table 3 .					
3. For recommended operating conditions, see Table 3 .					

This table provides the DC electrical characteristics for Flextimer pins operating at $L/V_{\text{DD}}/L1V_{\text{DD}} = 2.5 \text{ V}$.

Table 85. Flextimer DC electrical characteristics (2.5 V)³

Parameter	Symbol	Min	Max	Unit	Notes
Input high voltage	V_{IH}	$0.7 \times nV_{DD}$	—	V	1
Input low voltage	V_{IL}	—	$0.2 \times nV_{DD}$	V	1
Input current ($V_{IN} = 0$ V or $V_{IN} = LV_{DD}/L1V_{DD}$)	I_{IN}	—	± 50	μ A	2
Output high voltage ($LV_{DD}/L1V_{DD} = \text{min}$, $I_{OH} = -1$ mA)	V_{OH}	2.0	—	V	—
Output low voltage ($LV_{DD}/L1V_{DD} = \text{min}$, $I_{OL} = 1$ mA)	V_{OL}	—	0.4	V	—

Notes:

1. The min V_{IL} and max V_{IH} values are based on the respective min and max $LV_{IN}/L1V_{IN}$ values found in [Table 3](#).
2. The symbol V_{IN} , in this case, represents the $LV_{IN}/L1V_{IN}$ symbol referenced in [Table 3](#).
3. For recommended operating conditions, see [Table 3](#).

This table provides the DC electrical characteristics for Flextimer pins operating at $L/L1/D/BV_{DD} = 1.8$ V.

Table 86. Flextimer DC electrical characteristics (1.8 V)³

Parameter	Symbol	Min	Max	Unit	Notes
Input high voltage	V_{IH}	$0.7 \times nV_{DD}$	—	V	1
Input low voltage	V_{IL}	—	$0.2 \times nV_{DD}$	V	1
Input current ($V_{IN} = 0$ V or $V_{IN} = L/L1/D/BV_{DD}$)	I_{IN}	—	± 50	μ A	2
Output high voltage ($L/L1/D/BV_{DD} = \text{min}$, $I_{OH} = -0.5$ mA)	V_{OH}	1.35	—	V	—
Output low voltage ($L/L1/D/BV_{DD} = \text{min}$, $I_{OL} = 0.5$ mA)	V_{OL}	—	0.4	V	—

Notes:

1. The min V_{IL} and max V_{IH} values are based on the respective min and max $L/L1/D/BV_{IN}$ values found in [Table 3](#).
2. The symbol V_{IN} , in this case, represents the $L/L1/D/BV_{IN}$ symbol referenced in [Table 3](#).
3. For recommended operating conditions, see [Table 3](#).

3.17.2 Flextimer AC timing specifications

This table provides the Flextimer AC timing specifications.

Table 87. Flextimer AC timing specifications²

Parameter	Symbol	Min	Unit	Notes
Flextimer inputs—minimum pulse width	t_{PIWID}	20	ns	1
Notes:				
1. Flextimer inputs and outputs are asynchronous to any visible clock. Flextimer outputs should be synchronized before use by any external synchronous logic. Flextimer inputs are required to be valid for at least t_{PIWID} to ensure proper operation.				
2. For recommended operating conditions, see Table 3 .				

This figure provides the AC test load for the Flextimer.

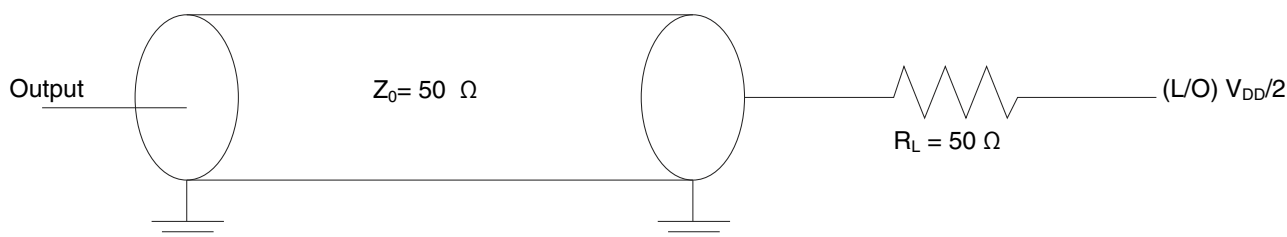
**Figure 46. Flextimer AC test load**

3.18 SAI/I²S interface

This section describes the DC and AC electrical characteristics for the SAI/I²S interface. There are SAI/I²S pins on various power supplies in this device.

3.18.1 SAI/I²S DC electrical characteristics

This table provides the SAI/I²S DC electrical characteristics when $L1V_{DD}/DV_{DD} = 3.3$ V.

Table 88. SAI/I²S DC electrical characteristics ($L1V_{DD}/DV_{DD} = 3.3$ V)⁴

Parameter	Symbol	Min	Max	Unit	Notes
Input high voltage	V_{IH}	$0.7 \times nV_{DD}$	—	V	1
Input low voltage	V_{IL}	—	$0.2 \times nV_{DD}$	V	1
Input current ($L1V_{IN} = 0$ V or $L1V_{IN} = L1V_{DD}$)	I_{IN}	—	± 50	μ A	2, 3
Output high voltage ($L1V_{DD} = \text{min}$, $I_{OH} = -2$ mA)	V_{OH}	2.4	—	V	—
Output low voltage ($L1V_{DD} = \text{min}$, $I_{OL} = 2$ mA)	V_{OL}	—	0.4	V	—
Notes:					
1. The min V_{IL} and max V_{IH} values are based on the respective min and max $L1V_{IN}/DV_{IN}$ values found in Table 3 .					
2. The symbol $L1V_{IN}$, in this case, represents the $L1V_{IN}/DV_{IN}$ symbol referenced in Table 3 .					

Table 88. SAI/I²S DC electrical characteristics (L1V_{DD}/DV_{DD} = 3.3 V)⁴

Parameter	Symbol	Min	Max	Unit	Notes
3. The symbol L1V _{DD} , in this case, represents the L1V _{DD} /DV _{DD} symbols referenced in Table 3 .					
4. For recommended operating conditions, see Table 3 .					

This table provides the SAI/I²S DC electrical characteristics when L1V_{DD} = 2.5 V.

Table 89. SAI/I²S DC electrical characteristics (L1V_{DD}/DV_{DD} = 2.5 V)⁴

Parameters	Symbol	Min	Max	Unit	Notes
Input high voltage	V _{IH}	0.7 x nV _{DD}	—	V	1
Input low voltage	V _{IL}	—	0.2 x nV _{DD}	V	1
Input current (L1V _{IN} = 0 or L1V _{IN} = L1V _{DD} /DV _{DD})	I _{IN}	—	±50	µA	2, 3
Output high voltage (L1V _{DD} = min, I _{OH} = -1.0 mA)	V _{OH}	2.00	—	V	—
Output low voltage (L1V _{DD} = min, I _{OL} = 1.0 mA)	V _{OL}	—	0.40	V	—

Notes:

- The min V_{IL} and max V_{IH} values are based on the respective min and max L1V_{IN}/DV_{DD} values found in [Table 3](#).
- The symbol V_{IN}, in this case, represents the L1V_{IN}/DV_{DD} symbols referenced in [Table 3](#).
- The symbol L1V_{DD}, in this case, represents the L1V_{DD}/DV_{DD} symbols referenced in [Table 3](#).
- For recommended operating conditions, see [Table 3](#).

This table provides the SAI/I²S DC electrical characteristics when L1V_{DD}/DV_{DD} = 1.8 V.

Table 90. SAI/I²S DC electrical characteristics (L1V_{DD}/DV_{DD} = 1.8 V)⁴

Parameter	Symbol	Min	Max	Unit	Notes
Input high voltage	V _{IH}	0.7 x nV _{DD}	—	V	1
Input low voltage	V _{IL}	—	0.2 x nV _{DD}	V	1
Input current (L1V _{IN} = 0 V or L1V _{IN} = L1V _{DD})	I _{IN}	—	±50	µA	2, 3
Output high voltage (L1V _{DD} = min, I _{OH} = -0.5 mA)	V _{OH}	1.35	—	V	3
Output low voltage (L1V _{DD} = min, I _{OL} = 0.5 mA)	V _{OL}	—	0.4	V	3

Notes:

- The min V_{IL} and max V_{IH} values are based on the min and max L1V_{IN}/DV_{DD} respective values found in [Table 3](#).
- The symbol L1V_{IN} represents the L1V_{IN}/DV_{DD} symbols referenced in [Table 3](#).
- The symbol L1V_{DD}, in this case, represents the L1V_{DD}/DV_{DD} symbols referenced in [Table 3](#).
- For recommended operating conditions, see [Table 3](#).

3.18.2 SAI/I²S AC timing specifications

This section provides the AC timings for the synchronous audio interface (SAI) in master (clocks driven) and slave (clocks input) modes.

Electrical characteristics

This table provides the SAI timing in master mode.

Table 91. Master mode SAI timing

Parameter	Symbol	Min	Max	Unit
SAIn_TX_BCLK/SAIn_RX_BCLK cycle time	t_{SAIC}	20	-	ns
SAIn_TX_BCLK/SAIn_RX_BCLK pulse width high/low	t_{SAIL}/t_{SAIH}	35%	65%	BCLK period
SAIn_TX_BCLK to SAI _n _TX_SYNC output valid	$t_{SAIMFSLOV}$	-	15	ns
SAIn_TX_BCLK to SAI _n _TX_SYNC output invalid	$t_{SAIMFSLOX}$	0	-	ns
SAIn_TX_BCLK to SAI _n _TX_DATA valid	$t_{SAIMLDV}$	-	15	ns
SAIn_TX_BCLK to SAI _n _TX_DATA invalid	$t_{SAIMLDX}$	0	-	ns
SAIn_RX_DATA/SAIn_RX_SYNC input setup before SAI _n _RX_BCLK	$t_{SAIMVKH}$	15	-	ns
SAIn_RX_DATA/SAIn_RX_SYNC input hold after SAI _n _RX_BCLK	$t_{SAIMXKH}$	0	-	ns

This figure shows the SAI timing in master modes.

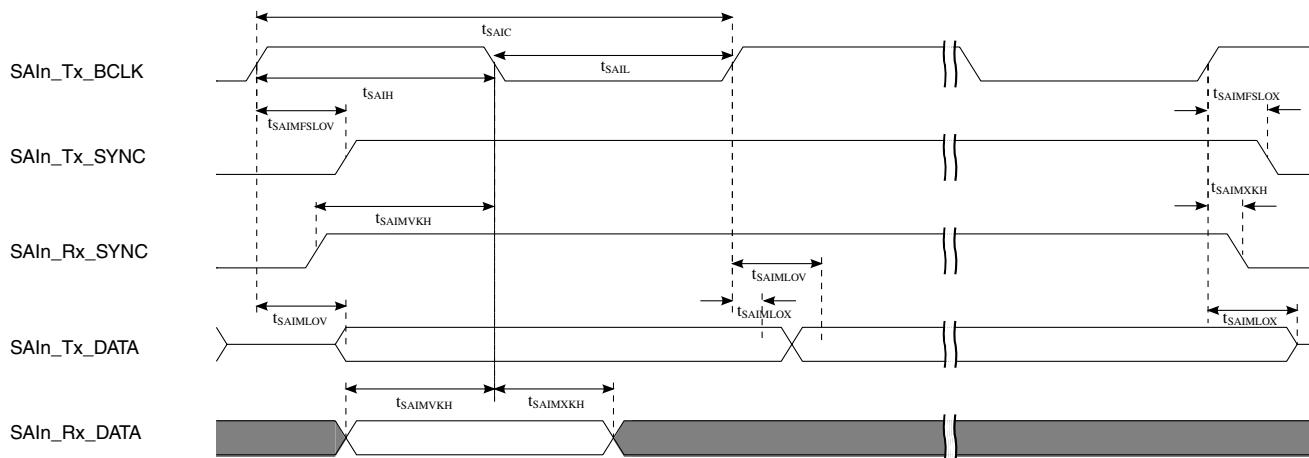

Figure 47. SAI timing — master modes

This table provides the SAI timing in slave mode.

Table 92. Slave mode SAI timing

Parameter	Symbol	Min	Max	Unit
SAIn_TX_BCLK/SAIn_RX_BCLK cycle time (input)	t_{SAIC}	20	-	ns
SAIn_TX_BCLK/SAIn_RX_BCLK pulse width high/low (input)	t_{SAIL}/t_{SAIH}	35%	65%	BCLK period

Table continues on the next page...

Table 92. Slave mode SAI timing (continued)

SAIn_RX_SYNC input setup before SAIn_RX_BCLK	$t_{SAISFSVKH}$	10	-	ns
SAIn_RX_SYNC input hold after SAIn_RX_BCLK	$t_{SAISFSXKH}$	2.1	-	ns
SAIn_TX_BCLK to SAIn_TX_DATA / SAIn_TX_SYNC output valid	$t_{SAISLOV}$	-	20	ns
SAIn_TX_BCLK to SAIn_TX_DATA/ SAIn_TX_SYNC output invalid	$t_{SAISLOX}$	0	-	ns
SAIn_RX_DATA setup before SAIn_RX_BCLK	$t_{SAISVKH}$	10	-	ns
SAIn_RX_DATA hold after SAIn_RX_BCLK	$t_{SAISXKH}$	2.1	-	ns

This figure shows the SAI timing in slave modes.

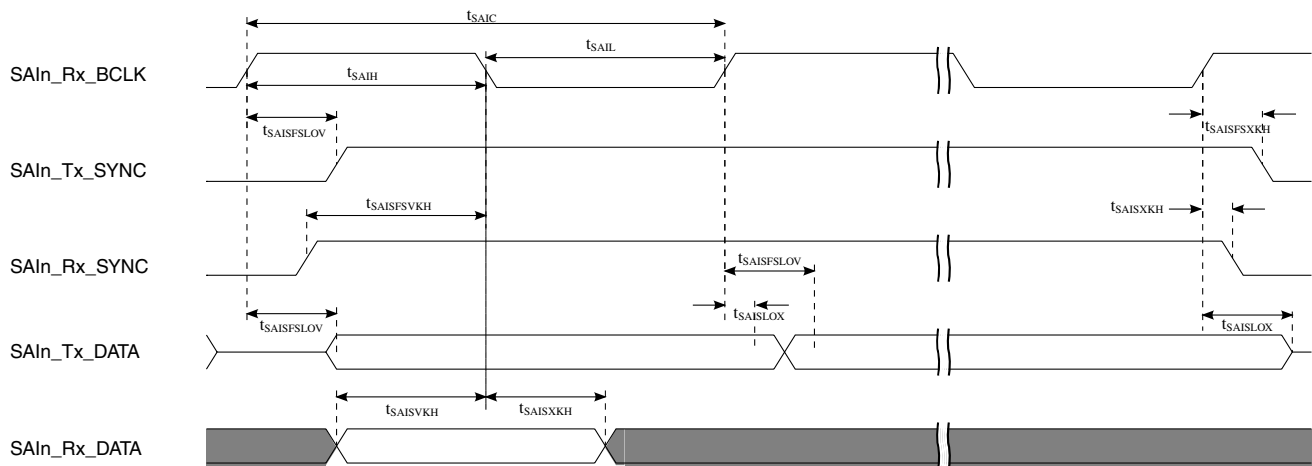
**Figure 48. SAI timing — slave modes**

3.19 SPDIF interface

This section describes the DC and AC electrical characteristics for the Sony/Philips Digital Interconnect Format (SPDIF) interface.

3.19.1 SPDIF DC electrical characteristics

This table provides the DC electrical characteristics for the SPDIF interface when operating at $DV_{DD} = 3.3\text{ V}$.

Electrical characteristics

Table 93. SPDIF DC electrical characteristics ($DV_{DD} = 3.3\text{ V}$)³

Parameter	Symbol	Min	Max	Unit	Notes
Input high voltage	V_{IH}	$0.7 \times DV_{DD}$	—	V	1
Input low voltage	V_{IL}	—	$0.2 \times DV_{DD}$	V	1
Input current ($V_{IN} = 0\text{ V}$ or $V_{IN} = DV_{DD}$)	I_{IN}	—	± 50	μA	2
Output high voltage ($DV_{DD} = \text{min}$, $I_{OH} = -2\text{ mA}$)	V_{OH}	2.4	—	V	—
Output low voltage ($DV_{DD} = \text{min}$, $I_{OH} = 2\text{ mA}$)	V_{OL}	—	0.4	V	—

Notes:

1. The min V_{IL} and max V_{IH} values are based on the respective min and max DV_{IN} values found in [Table 3](#).
2. The symbol V_{IN} , in this case, represents the input voltage of the supply referenced in [Table 3](#).
3. For recommended operating conditions, see [Table 3](#).

This table provides the DC electrical characteristics for the SPDIF interface when operating at $DV_{DD} = 1.8\text{ V}$.

Table 94. SPDIF DC electrical characteristics ($DV_{DD} = 1.8\text{ V}$)³

Parameter	Symbol	Min	Max	Unit	Notes
Input high voltage	V_{IH}	$0.7 \times DV_{DD}$	—	V	1
Input low voltage	V_{IL}	—	$0.2 \times DV_{DD}$	V	1
Input current ($V_{IN} = 0\text{ V}$ or $V_{IN} = DV_{DD}$)	I_{IN}	—	± 50	μA	2
Output high voltage ($DV_{DD} = \text{min}$, $I_{OH} = -0.5\text{ mA}$)	V_{OH}	1.35	—	V	—
Output low voltage ($DV_{DD} = \text{min}$, $I_{OH} = 0.5\text{ mA}$)	V_{OL}	—	0.4	V	—

Notes:

1. The min V_{IL} and max V_{IH} values are based on the respective min and max DV_{IN} values found in [Table 3](#).
2. The symbol V_{IN} , in this case, represents the input voltage of the supply referenced in [Table 3](#).
3. For recommended operating conditions, see [Table 3](#).

3.19.2 SPDIF AC timing specifications

This table provides the AC timing specifications for the SPDIF interface.

Table 95. SPDIF AC timing specifications

Characteristics	Symbol	Min	Max	Unit
SPDIF_IN	—	—	0.7	ns
Skew: Asynchronous inputs, no specifications apply				
SPDIF_OUT output (load = 50 pf)	Skew	—	—	1.5
	Transition rising	—	—	24.2
	Transition falling	—	—	31.3

Table continues on the next page...

**Table 95. SPDIF AC timing specifications
(continued)**

Characteristics	Symbol	Min	Max	Unit
SPDIF_SRCLK period	srckp	40.0	—	ns
SPDIF_SRCLK high period	srckph	16.0	—	ns
SPDIF_SRCLK low period	srckpl	16.0	—	ns
SPDIF_EXTCLK period	stckp	40.0	—	ns
SPDIF_EXTCLK high period	stckph	16.0	—	ns
SPDIF_EXTCLK low period	stckpl	16.0	—	ns

This figure shows the timing for SPDIF_SRCLK.

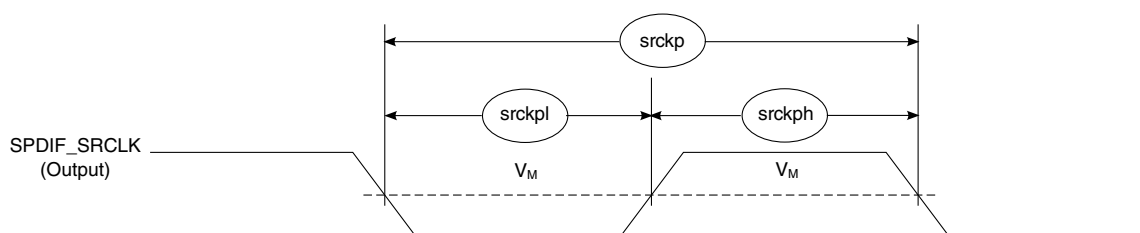

Figure 49. SPDIF_SRCLK timing

This figure shows the timing for SPDIF_EXTCLK.

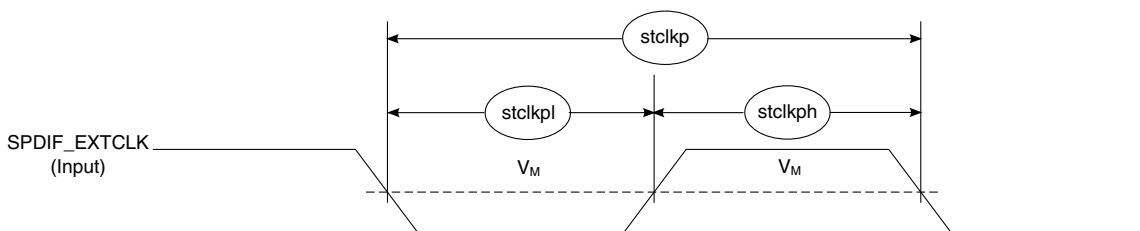

Figure 50. SPDIF_EXTCLK timing

3.20 SPI interface

This section describes the DC and AC electrical characteristics for the SPI interface.

3.20.1 SPI DC electrical characteristics

This table provides the DC electrical characteristics for the SPI interface operating at $BV_{DD} = 3.3\text{ V}$.

Table 96. SPI DC electrical characteristics (3.3 V)³

Parameter	Symbol	Min	Max	Unit	Notes
Input high voltage	V_{IH}	$0.7 \times BV_{DD}$	—	V	1
Input low voltage	V_{IL}	—	$0.2 \times BV_{DD}$	V	1
Input current ($V_{IN} = 0$ V or $V_{IN} = BV_{DD}$)	I_{IN}	—	± 50	μA	2
Output high voltage ($BV_{DD} = \text{min}$, $I_{OH} = -2$ mA)	V_{OH}	2.4	—	V	—
Output low voltage ($BV_{DD} = \text{min}$, $I_{OL} = 2$ mA)	V_{OL}	—	0.4	V	—

Notes:

1. The min V_{IL} and max V_{IH} values are based on the respective min and max BV_{IN} values found in [Table 3](#).
2. The symbol V_{IN} , in this case, represents the BV_{IN} symbol referenced in [Table 3](#).
3. For recommended operating conditions, see [Table 3](#).

This table provides the DC electrical characteristics for the SPI interface operating at $BV_{DD} = 1.8$ V.

Table 97. SPI DC electrical characteristics (1.8 V)³

Parameter	Symbol	Min	Max	Unit	Notes
Input high voltage	V_{IH}	$0.7 \times BV_{DD}$	—	V	1
Input low voltage	V_{IL}	—	$0.2 \times BV_{DD}$	V	1
Input current ($V_{IN} = 0$ V or $V_{IN} = BV_{DD}$)	I_{IN}	—	± 50	μA	2
Output high voltage ($BV_{DD} = \text{min}$, $I_{OH} = -0.5$ mA)	V_{OH}	1.35	—	V	—
Output low voltage ($BV_{DD} = \text{min}$, $I_{OL} = 0.5$ mA)	V_{OL}	—	0.4	V	—

Notes:

1. The min V_{IL} and max V_{IH} values are based on the respective min and max BV_{IN} values found in [Table 3](#).
2. The symbol V_{IN} , in this case, represents the BV_{IN} symbol referenced in [Table 3](#).
3. For recommended operating conditions, see [Table 3](#).

3.20.2 SPI AC timing specifications

This table provides the SPI timing specifications.

Table 98. SPI AC timing specifications

Parameter	Symbol	Condition	Min	Max	Unit
SCK Cycle Time	t_{SCK}	—	$TPlat*8$	—	ns

Table continues on the next page...

**Table 98. SPI AC timing specifications
(continued)**

Parameter	Symbol	Condition	Min	Max	Unit
SCK Clock Pulse Width	t_{SDC}	—	40%	60%	t_{SCK}
CS to SCK Delay	t_{CSC}	Master	16	—	ns
After SCK Delay	t_{ASC}	Master	16	—	ns
Slave Access Time (SS active to SOUT driven)	t_A	Slave	—	15	ns
Slave Disable Time (SS inactive to SOUT High-Z or invalid)	t_{DI}	Slave	—	10	ns
Data Setup Time for Inputs	t_{NIIVKH}	Master	8	—	ns
	t_{NEIVKH}	Slave	4	—	
Data Hold Time for Inputs	t_{NIIXKH}	Master	0	—	ns
	t_{NEIXKH}	Slave	2	—	
Data Valid (after SCK edge) for Outputs	t_{NIKHOV}	Master	—	5	ns
	t_{NEKHOV}	Slave	—	10	
Data Hold Time for Outputs	t_{NIKHOX}	Master	0	—	ns
	t_{NEKHOX}	Slave	0	—	

This figure shows the SPI timing master when $CPHA = 0$.

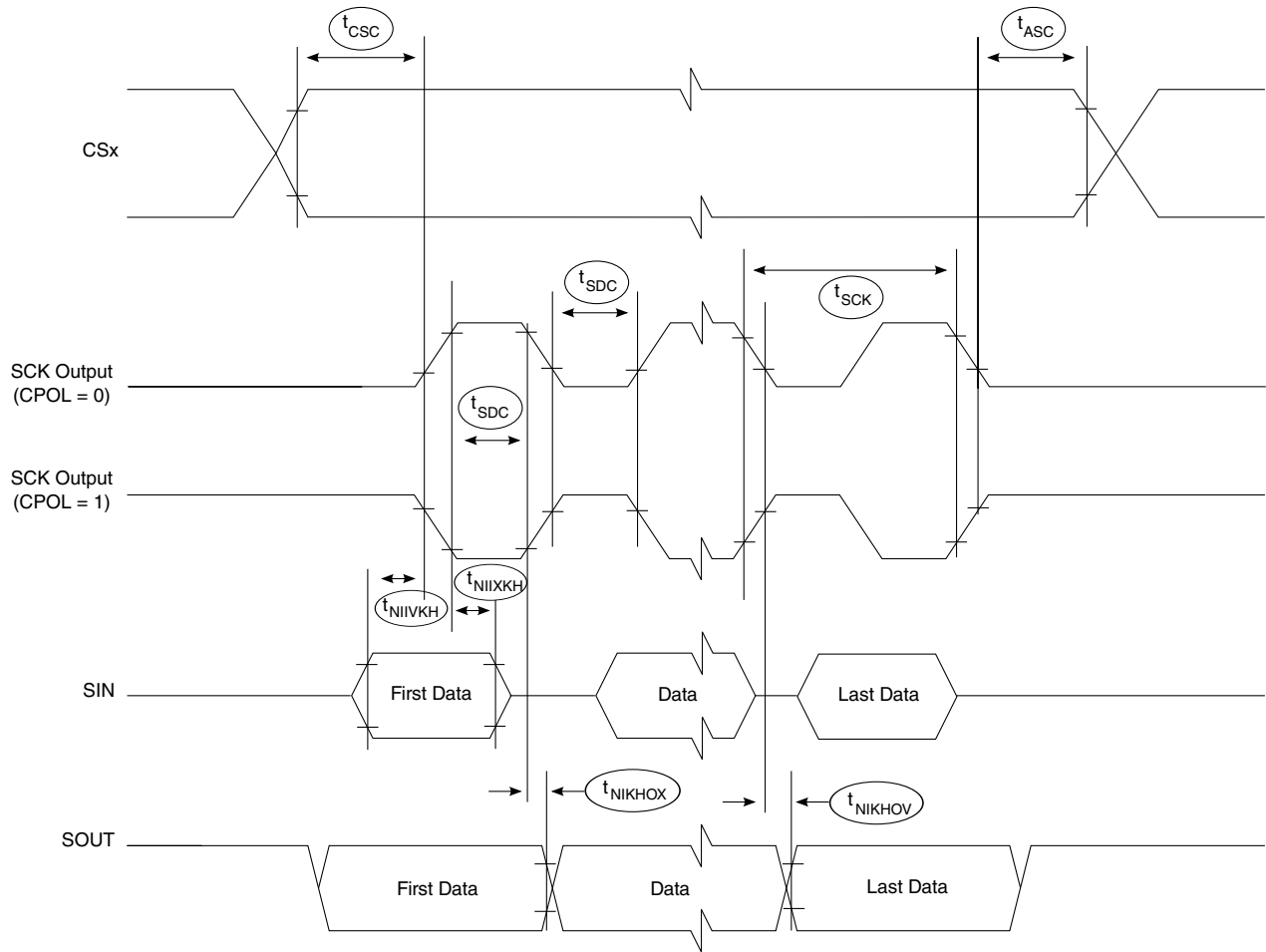

Figure 51. SPI timing master, CPHA = 0

This figure shows the SPI timing master when CPHA = 1.

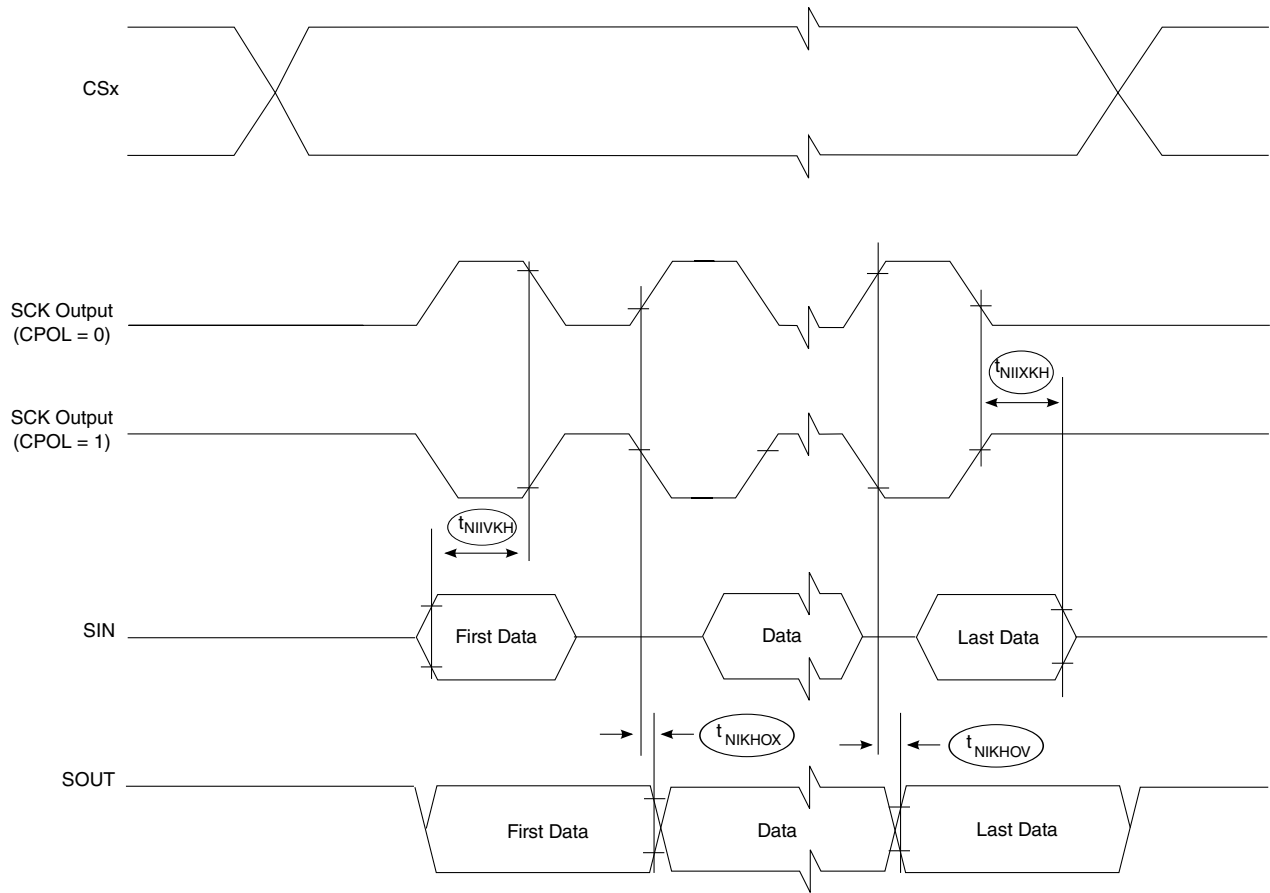

Figure 52. SPI timing master, CPHA = 1

This figure shows the SPI timing slave when CPHA = 0.

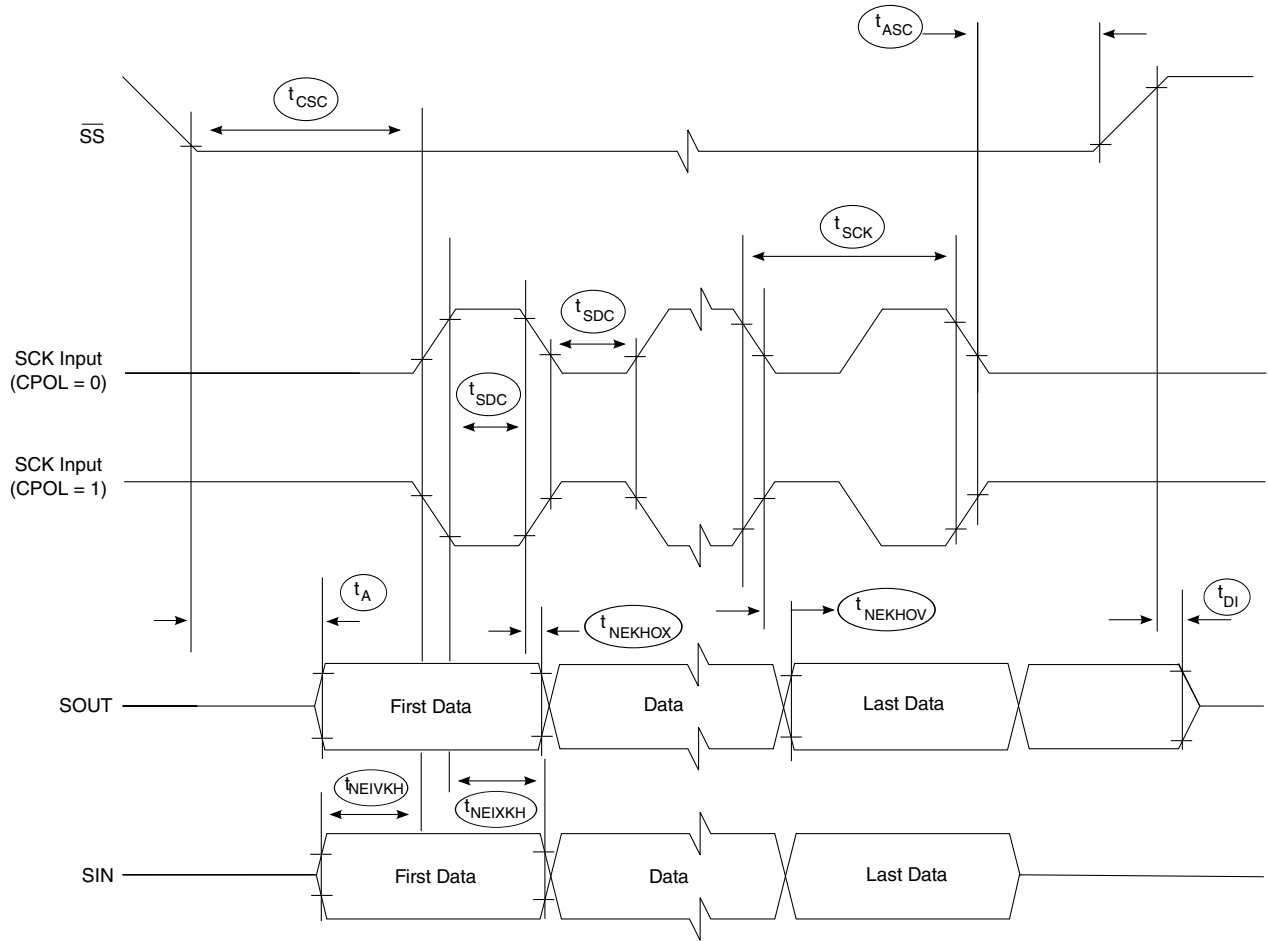

Figure 53. SPI timing slave, CPHA = 0

This figure shows the SPI timing slave when CPHA = 1.

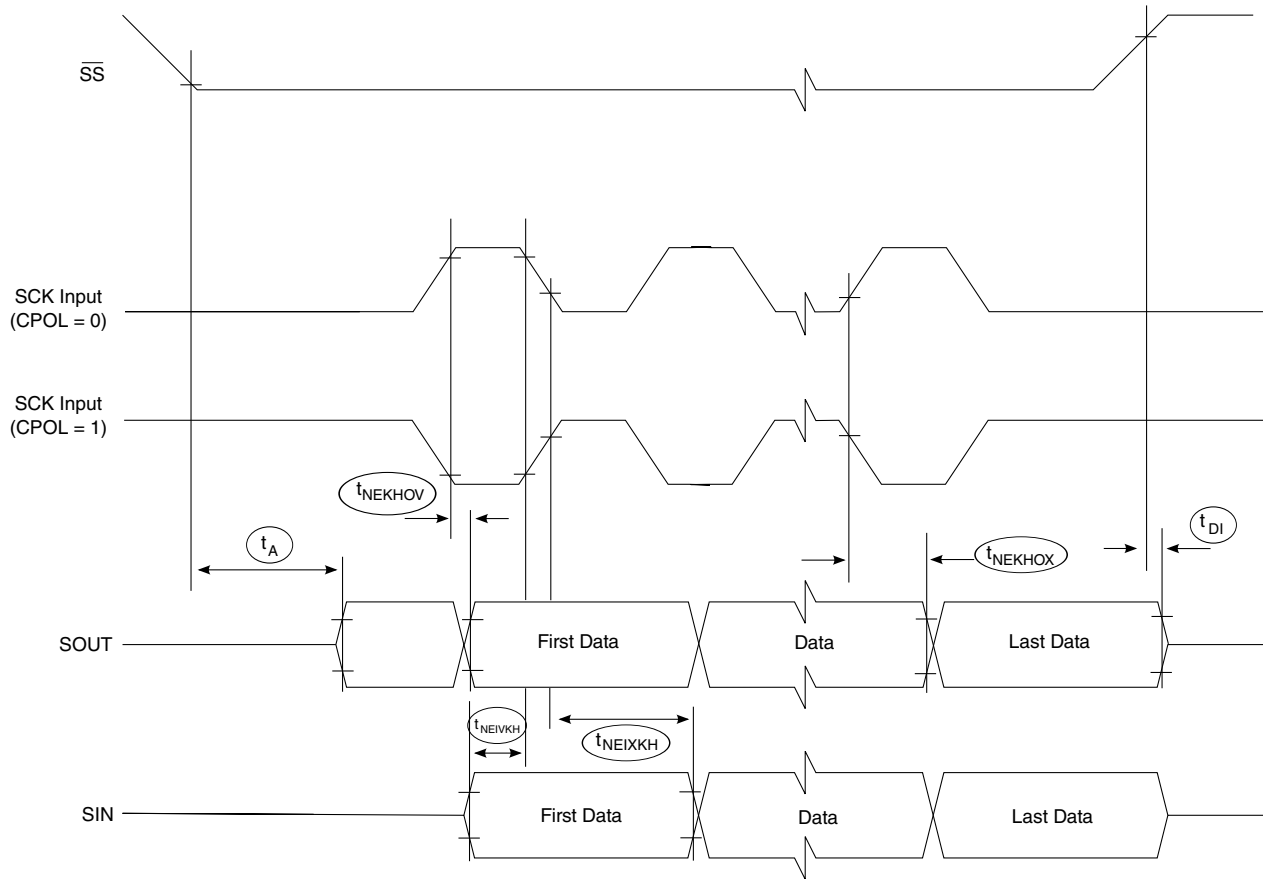

Figure 54. SPI timing slave, CPHA = 1

3.21 QuadSPI interface

This section describes the DC and AC electrical characteristics for the QuadSPI interface.

3.21.1 QuadSPI DC electrical characteristics

This table provides the DC electrical characteristics for the QuadSPI interface operating at $BV_{DD} = 3.3\text{ V}$.

Table 99. QuadSPI DC electrical characteristics (3.3 V)³

Parameter	Symbol	Min	Max	Unit	Notes
Input high voltage	V_{IH}	$0.7 \times BV_{DD}$	—	V	1
Input low voltage	V_{IL}	—	$0.2 \times BV_{DD}$	V	1
Input current ($V_{IN} = 0\text{ V}$ or $V_{IN} = BV_{DD}$)	I_{IN}	—	± 50	μA	2
Output high voltage	V_{OH}	2.4	—	V	—

Table continues on the next page...

Table 99. QuadSPI DC electrical characteristics (3.3 V)³ (continued)

Parameter	Symbol	Min	Max	Unit	Notes
(BV _{DD} = min, I _{OH} = -2 mA)					
Output low voltage (BV _{DD} = min, I _{OL} = 2 mA)	V _{OL}	—	0.4	V	—
Notes:					
1. The min V _{IL} and max V _{IH} values are based on the respective min and max BV _{IN} values found in Table 3 .					
2. The symbol V _{IN} , in this case, represents the BV _{IN} symbol referenced in Table 3 .					
3. For recommended operating conditions, see Table 3 .					

This table provides the DC electrical characteristics for the QuadSPI interface operating at BV_{DD} = 1.8 V.

Table 100. QuadSPI DC electrical characteristics (1.8 V)³

Parameter	Symbol	Min	Max	Unit	Notes
Input high voltage	V _{IH}	0.7 x BV _{DD}	—	V	1
Input low voltage	V _{IL}	—	0.2 x BV _{DD}	V	1
Input current (V _{IN} = 0 V or V _{IN} = BV _{DD})	I _{IN}	—	±50	μA	2
Output high voltage (BV _{DD} = min, I _{OH} = -0.5 mA)	V _{OH}	1.35	—	V	—
Output low voltage (BV _{DD} = min, I _{OL} = 0.5 mA)	V _{OL}	—	0.4	V	—
Notes:					
1. The min V _{IL} and max V _{IH} values are based on the respective min and max BV _{IN} values found in Table 3 .					
2. The symbol V _{IN} , in this case, represents the BV _{IN} symbol referenced in Table 3 .					
3. For recommended operating conditions, see Table 3 .					

3.21.2 QuadSPI AC timing specifications

This section describes the QuadSPI timing specifications in SDR mode. All data is based on a negative edge data launch from the device and a positive edge data capture, as shown in the timing figures in this section.

3.21.2.1 QuadSPI timing SDR mode

This table provides the QuadSPI input and output timing in SDR mode.

Table 101. SDR mode QuadSPI input and output timing

Parameter	Symbol	Min	Max	Unit
Clock rise/fall time	T_{RISE}/T_{FALL}	1	—	ns
CS output hold time	$t_{NIKHOX2}$	-3.4	—	ns
CS output delay	$t_{NIKHOV2}$	—	3.5	ns
Setup time for incoming data	t_{NIIVKH}	8.6	—	ns
Hold time requirement for incoming data	t_{NIIXKH}	0.4	—	ns
Output data valid	t_{NIKHOV} t_{NIKLOV}	—	4.5	ns
Output data hold	t_{NIKHOX} t_{NIKLOX}	-4.4	—	ns

Notes:

1. The input timing is relative to the sampling clock edge which is configurable. Please refer to register QuadSPI_SMPR from *LS102xA Reference Manual* for more information.

This figure shows the QuadSPI AC timing in SDR mode.

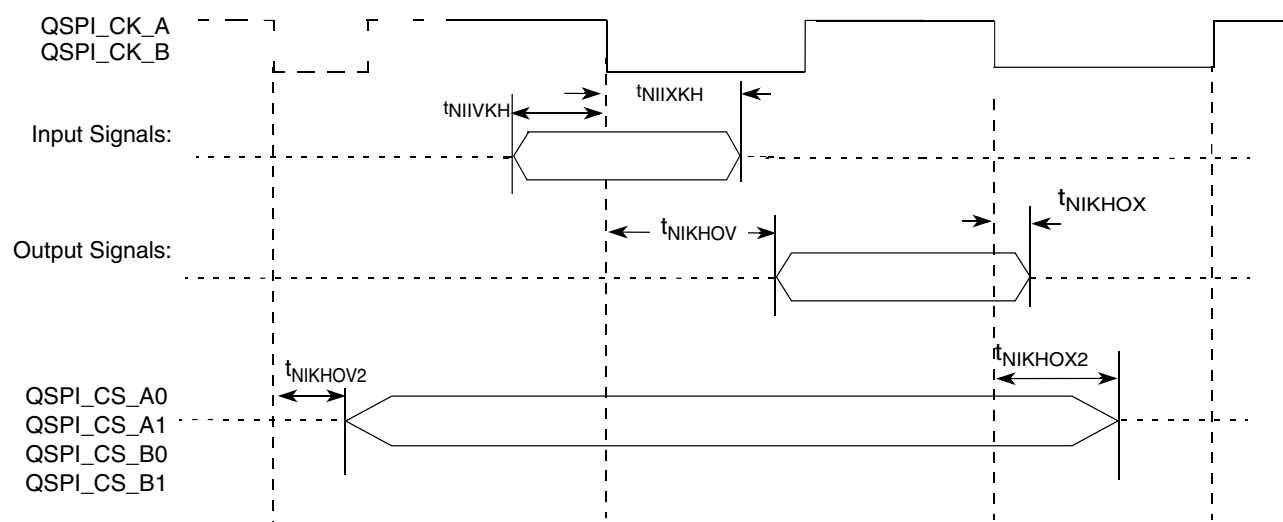
**Figure 55. QuadSPI AC timing — SDR mode**

3.22 Enhanced secure digital host controller (eSDHC)

This section describes the DC and AC electrical specifications for the eSDHC interface.

Note: This section is preliminary and is subject to further change.

3.22.1 eSDHC DC electrical characteristics

This table provides the DC electrical characteristics for the eSDHC interface operating at $D/EV_{DD} = 3.3\text{ V}$.

Table 102. eSDHC interface DC electrical characteristics³

Characteristic	Symbol	Condition	Min	Max	Unit	Notes
Input high voltage	V_{IH}	—	$0.7 \times EV_{DD}$	—	V	1
Input low voltage	V_{IL}	—	—	$0.2 \times EV_{DD}$	V	1
Output high voltage	V_{OH}	$I_{OH} = -100\ \mu\text{A}$ at EV_{DD} min	$0.75 \times EV_{DD}$	—	V	—
Output low voltage	V_{OL}	$I_{OL} = 100\ \mu\text{A}$ at EV_{DD} min	—	$0.125 \times EV_{DD}$	V	—
Output high voltage	V_{OH}	$I_{OH} = -100\ \mu\text{A}$	$EV_{DD} - 0.2$	—	V	2
Output low voltage	V_{OL}	$I_{OL} = 2\ \text{mA}$	—	0.3	V	2
Input/output leakage current	I_{IN}/I_{OZ}	—	-10	10	μA	—

Notes:

1. The min V_{IL} and max V_{IH} values are based on the respective min and max EV_{IN} values found in [Table 3](#).
2. Open-drain mode is for MMC cards only.
3. The eSDHC interface is powered by DV_{DD} and EV_{DD} .

This table provides the DC electrical characteristics for the eSDHC interface operating at $D/EV_{DD} = 1.8\text{ V}$ or 3.3 V .

Table 103. eSDHC interface DC electrical characteristics (dual-voltage cards)^{1, 4}

Characteristic	Symbol	Condition	Min	Max	Unit	Notes
Input high voltage	V_{IH}	—	$0.7 \times EV_{DD}$	—	V	2
Input low voltage	V_{IL}	—	—	$0.25 \times EV_{DD}$	V	2
Output high voltage	V_{OH}	$I_{OH} = -100\ \mu\text{A}$ at EV_{DD} min	$EV_{DD} - 0.2\text{ V}$	—	V	—
Output low voltage	V_{OL}	$I_{OL} = 100\ \mu\text{A}$ at EV_{DD} min	—	0.2	V	—
Output high voltage	V_{OH}	$I_{OH} = -100\ \mu\text{A}$	$EV_{DD} - 0.2$	—	V	3
Output low voltage	V_{OL}	$I_{OL} = 2\ \text{mA}$	—	0.3	V	3
Input/Output leakage current	I_{IN}/I_{OZ}	—	-10	10	μA	—

Notes:

1. The eSDHC interface is powered by DV_{DD} and EV_{DD} .
2. The min V_{IL} and V_{IH} values are based on the respective min and max D/EV_{IN} values found in [Table 3](#).
3. Open-drain mode is for MMC cards only.
4. For recommended operating conditions, see [Table 3](#).

3.22.2 eSDHC AC timing specifications

This section provides the AC timing specifications.

This table provides the eSDHC AC timing specifications as defined in [Figure 56](#) and [Figure 57](#) ($EV_{DD}/DV_{DD} = 1.8\text{ V}$ or 3.3 V).

Table 104. eSDHC AC timing specifications (high speed/ full speed)⁶

Parameter		Symbol ¹	Min	Max	Unit	Notes
SDHC_CLK clock frequency	SD/SDIO (full-speed/high-speed mode)	f_{SHSCK}	0	25/46.5	MHz	2, 4
	MMC full-speed/high-speed mode			20/46.5		
SDHC_CLK clock low time (full-speed/high-speed mode)		t_{SHSCLK}	10/7	—	ns	4
SDHC_CLK clock high time (full-speed/high-speed mode)		$t_{SHSSCKH}$	10/7	—	ns	4
SDHC_CLK clock rise and fall times		$t_{SHSCKR}/$ t_{SHSCKF}	—	3	ns	4
Input setup times: SDHC_CMD, SDHC_DATx, to SDHC_CLK		t_{SHIVKH}	4.1	—	ns	3, 4, 5
Input hold times: SDHC_CMD, SDHC_DATx, to SDHC_CLK		t_{SHIXKH}	2.5	—	ns	3, 4, 5
Output hold time: SDHC_CLK to SDHC_CMD, SDHC_DATx valid		t_{SHKHGX}	-3	—	ns	3, 4, 5
Output delay time: SDHC_CLK to SDHC_CMD, SDHC_DATx valid		t_{SHKHGX}	—	3.3	ns	3, 4, 5
Notes:						
1. The symbols used for timing specifications follow these patterns: $t_{(\text{first three letters of functional block})(\text{signal})(\text{state}) (\text{reference})(\text{state})}$ for inputs and $t_{(\text{first three letters of functional block})(\text{reference})(\text{state})(\text{signal})(\text{state})}$ for outputs. For example, $t_{SHDKHOX}$ symbolizes eSDHC device timing (SH) Data (D) Command (C) clock reference (K) going to the high (H) state, with respect to the output (O) reaching the invalid state (X) or output hold time. Note that, in general, the clock reference symbol is based on five letters representing the clock of a particular function. For rise and fall times, the latter convention is used with the appropriate letter: R (rise) or F (fall).						
2. In full-speed mode, the clock frequency value can be 0-25 MHz for an SD/SDIO card and 0-20 MHz for an MMC card. In high-speed mode, the clock frequency value can be 0-50 MHz for an SD/SDIO card and 0-52 MHz for an MMC card.						
3. Without voltage translator and SDHC_CLK_SYNC_IN and SDHC_CLK_SYNC_OUT, to satisfy setup timing, one-way board-routing delay between host and card, on SDHC_CLK, SDHC_CMD, and SDHC_DATx should not exceed 1 ns for any high-speed MMC card. For any high-speed or default-speed mode SD card, the one-way board routing delay between host and card, on SDHC_CLK, SDHC_CMD, and SDHC_DATx should not exceed 1.5 ns. With a voltage translator, a 1.7 ns skew for input setup time and 0.5 ns skew for output delay time are considered in the table.						
4. $C_{CARD} \leq 10\text{ pF}$, (1 card), and $C_L = C_{BUS} + C_{HOST} + C_{CARD} \leq 40\text{ pF}$.						
5. The parameter values apply to both full-speed and high-speed modes.						
6. For recommended operating conditions, see Table 3 .						

This figure shows the eSDHC clock input timing diagram.

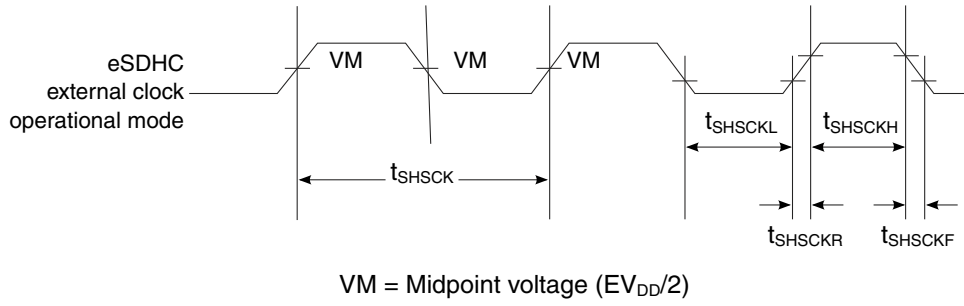

Figure 56. eSDHC clock input timing diagram

This figure shows the eSDHC input AC timing diagram for high-speed mode.

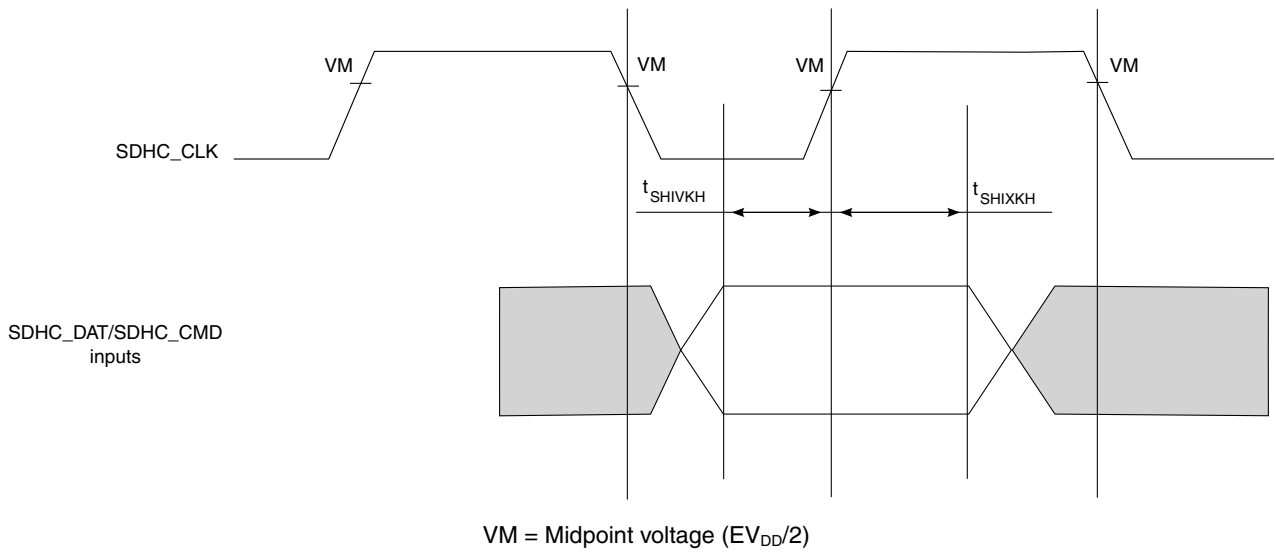

Figure 57. eSDHC high-speed mode input AC timing diagram

This figure shows the eSDHC output AC timing diagram for high-speed mode.

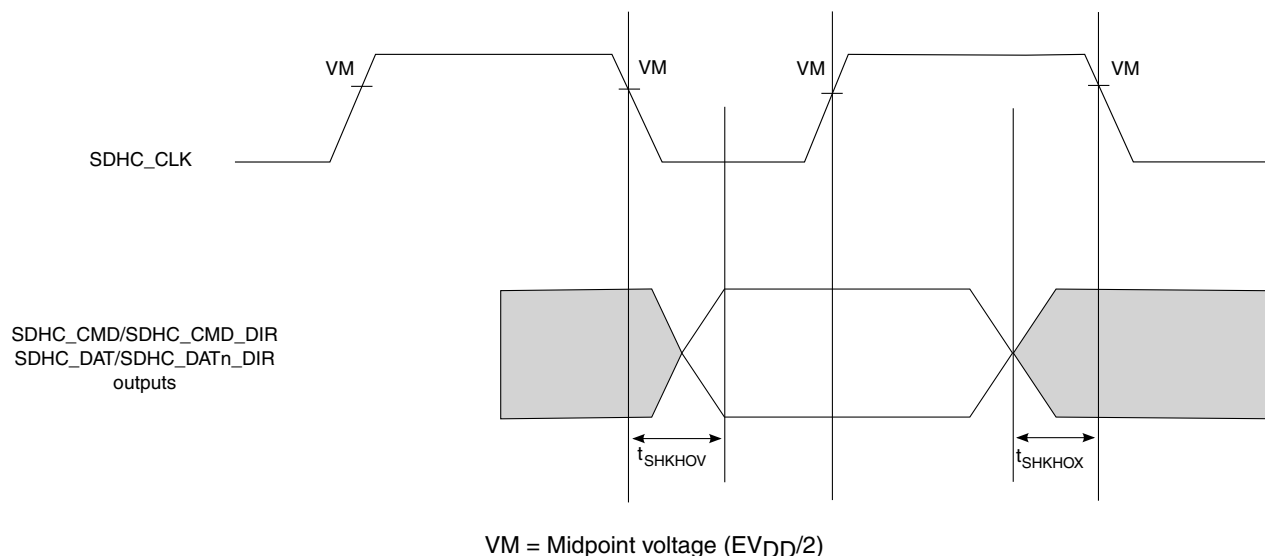

Figure 58. eSDHC high-speed mode output AC timing diagram

This table provides the eSDHC AC timing specifications for SDR50 mode ($E_{VDD}/DV_{DD} = 1.8$ V).

Table 105. eSDHC AC timing specifications (SDR50)²

Parameter	Symbol	Min	Max	Units	Notes
SDHC_CLK clock frequency	f_{SHSCK}	—	82	MHz	—
SDHC_CLK duty cycle	—	45	55	%	—
SDHC_CLK clock rise and fall times	$t_{SHSCKR}/$ t_{SHSCKF}	—	1	ns	1
Input setup times: SDHC_CMD, SDHC_DATx, to SDHC_CLK_SYNC_IN	t_{SHIVKH}	2.8	—	ns	—
Input hold times: SDHC_CMD, SDHC_DATx, to SDHC_CLK_SYNC_IN	t_{SHIXKH}	0.9	—	ns	—
Output hold time: SDHC_CLK to SDHC_CMD, SDHC_DATx valid, SDHC_DATx_DIR, SDHC_CMD_DIR	t_{SHKHOX}	1.9	—	ns	—
Output delay time: SDHC_CLK to SDHC_CMD, SDHC_DATx valid, SDHC_DATx_DIR, SDHC_CMD_DIR	t_{SHKHOV}	—	7.7	ns	—

Notes:

- $C_{CARD} \leq 10$ pF, (1 card), and $C_L = C_{BUS} + C_{HOST} + C_{CARD} \leq 30$ pF.
- For recommended operating conditions, see [Table 3](#).

This figure shows the eSDHC clock input timing diagram for SDR50 mode.

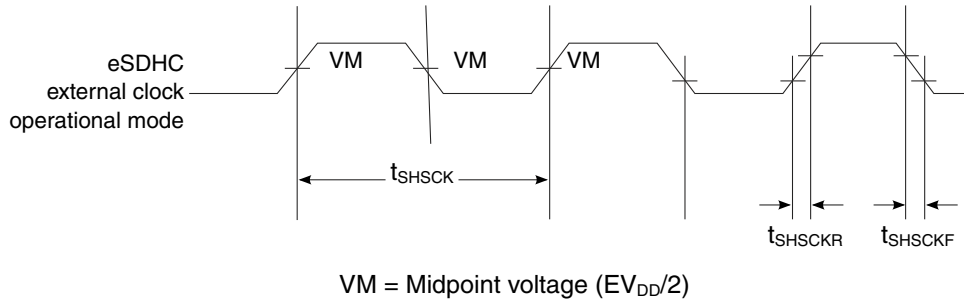

Figure 59. eSDHC SDR50 mode clock input timing diagram

This figure shows the eSDHC input AC timing diagram for SDR50 mode.

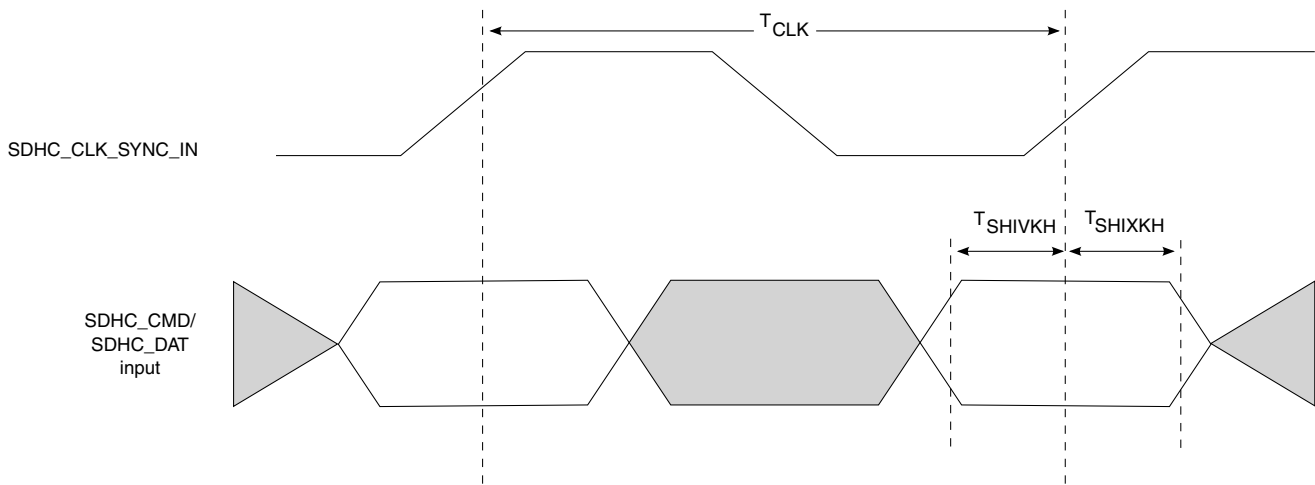

Figure 60. eSDHC SDR50 mode input AC timing diagram

This figure shows the eSDHC output AC timing diagram for SDR50 mode.

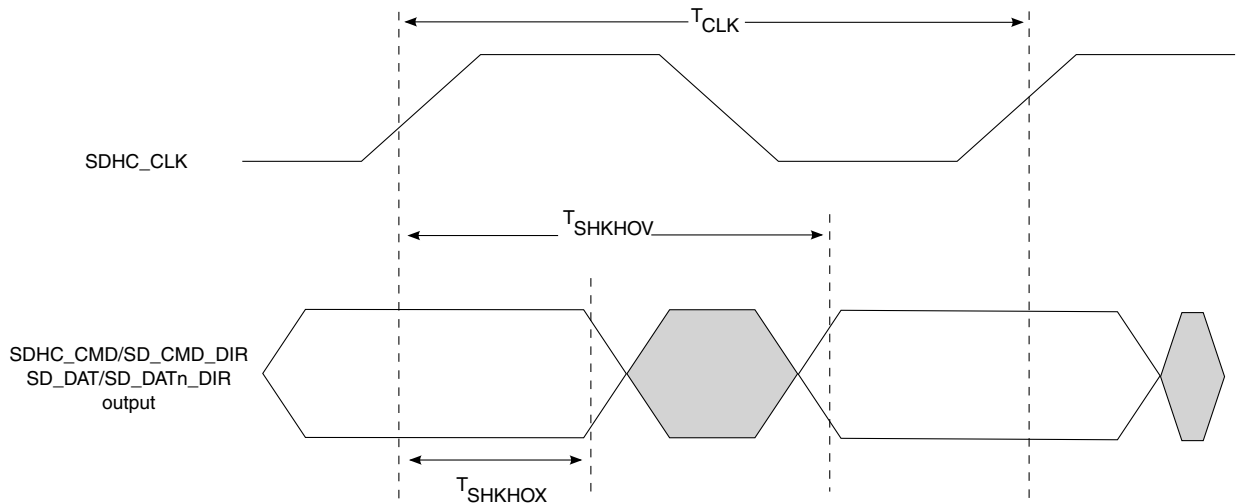

Figure 61. eSDHC SDR50 mode output AC timing diagram

This table provides the eSDHC AC timing specifications for DDR50/eMMC DDR mode ($EV_{DD}/DV_{DD} = 1.8\text{ V}$ for DDR50, $EV_{DD}/DV_{DD} = 1.8\text{ V}$ or 3.3 V for eMMC DDR mode).

Table 106. eSDHC AC timing specifications (DDR50/eMMC DDR)³

Parameter		Symbol	Min	Max	Units	Notes
SDHC_CLK clock frequency	SD/SDIO DDR50 mode	f_{SHSCK}	—	44	MHz	—
	eMMC DDR mode			44		
SDHC_CLK duty cycle		—	47	53	%	—
SDHC_CLK clock rise and fall times	SD/SDIO DDR50 mode	$t_{SHSCKR/}$	—	4	ns	1
	eMMC DDR mode	t_{SHSCKF}		2		2
Input setup times: SDHC_DATx to SDHC_CLK_SYNC_IN	SD/SDIO DDR50 mode	$t_{SHDIVKH}$	1.8V = 1.98ns	—	ns	—
	eMMC DDR mode		3.3V = 3.2ns 1.8V = 1.98ns			
Input hold times: SDHC_DATx to SDHC_CLK_SYNC_IN	SD/SDIO DDR50 mode	$t_{SHDIXKH}$	1.0	—	ns	—
	eMMC DDR mode		1.8V = 1.0ns 3.3V = 1.2ns			
Output hold time: SDHC_CLK to SDHC_DATx valid, SDHC_DATx_DIR	SD/SDIO DDR50 mode	$t_{SHDKHOX}$	2.2	—	ns	—
	eMMC DDR mode		3.92			
Output delay time: SDHC_CLK to SDHC_DATx valid, SDHC_DATx_DIR	SD/SDIO DDR50 mode	$t_{SHDKHOV}$	—	6.1	ns	—
	eMMC DDR mode			6.3		
Input setup times: SDHC_CMD to SDHC_CLK	SD/SDIO DDR50 mode	$t_{SHCIVKH}$	3.3	—	ns	—
	eMMC DDR mode		3.45			
Input hold times: SDHC_CMD to SDHC_CLK	SD/SDIO DDR50 mode	$t_{SHCIXKH}$	0.4	—	ns	—
	eMMC DDR mode		0.38			
Output hold time: SDHC_CLK to SDHC_CMD valid, SDHC_CMD_DIR	SD/SDIO DDR50 mode	$t_{SHCKHOX}$	2.2	—	ns	—
	eMMC DDR mode		4.42			
Output delay time: SDHC_CLK to SDHC_CMD valid, SDHC_CMD_DIR	SD/SDIO DDR50 mode	$t_{SHCKHOV}$	—	12.2	ns	—
	eMMC DDR mode			15.35		
Notes:						
1. $C_{CARD} \leq 10\text{ pF}$, (1 card).						
2. $C_L = C_{BUS} + C_{HOST} + C_{CARD} \leq 20\text{ pF}$ for MMC, 40 pF for SD.						
3. For recommended operating conditions, see Table 3 .						

This figure shows the eSDHC DDR50/eMMC DDR mode input AC timing diagram.

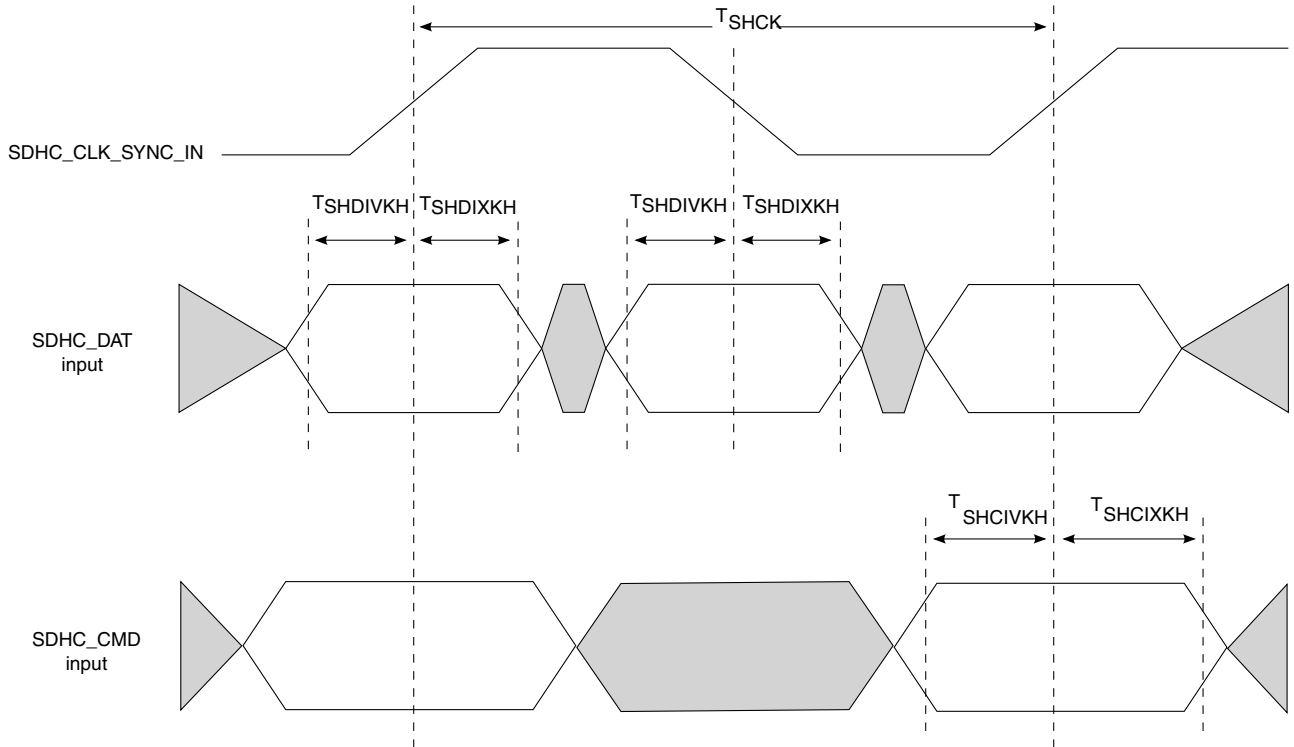
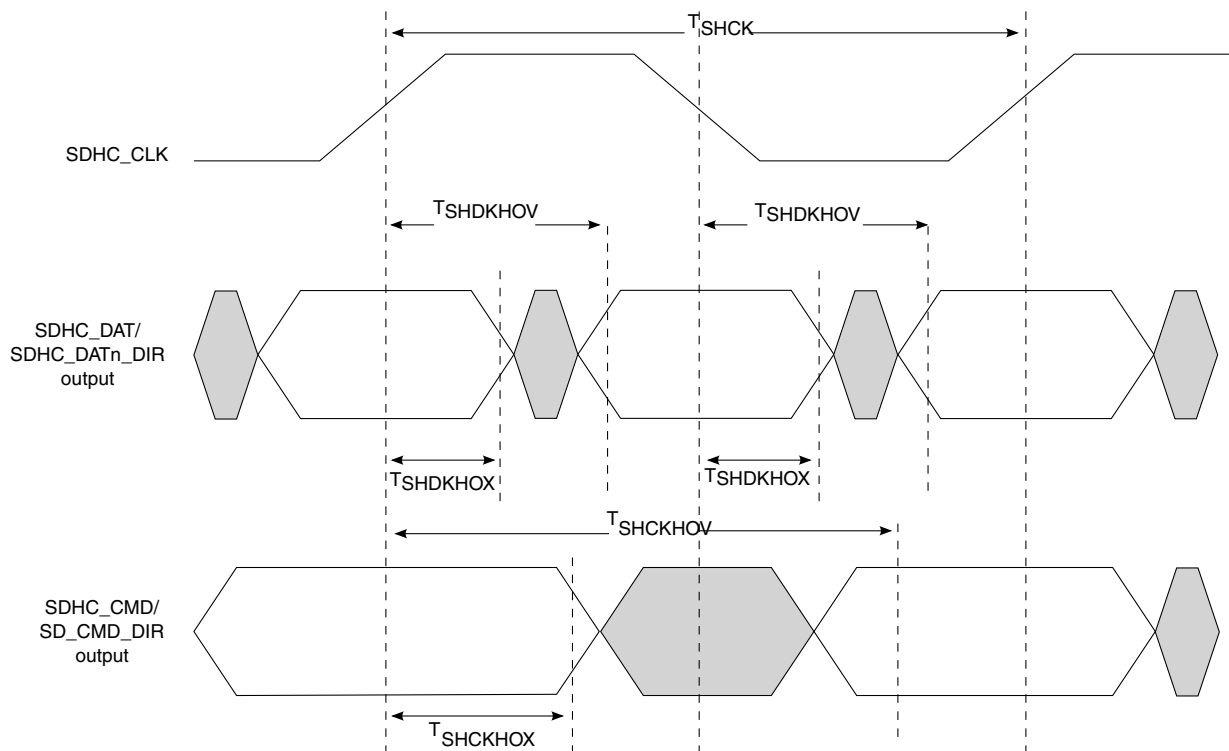

Figure 62. eSDHC DDR50/eMMC DDR mode input AC timing diagram

This figure shows the DDR50/eMMC DDR mode output AC timing diagram.

Figure 63. eSDHC DDR50/eMMC DDR mode output AC timing diagram

This table provides the eSDHC AC timing specifications for SDR104/eMMC HS200 mode ($EV_{DD}/DV_{DD} = 1.8$ V).

Table 107. eSDHC AC timing specifications (SDR104/eMMC HS200)²

Parameter		Symbol	Min	Max	Units	Notes
SDHC_CLK clock frequency	SD/SDIO SDR104 mode	f_{SHSCK}	—	166	MHz	—
	eMMC HS200 mode					
SDHC_CLK duty cycle		—	40	60	%	—
SDHC_CLK clock rise and fall times		$t_{SHSCKR}/$ t_{SHSCKF}	—	1	ns	1
Output hold time: SDHC_CLK to SDHC_CMD, SDHC DATx valid, SDHC_CMD_DIR, SDHC_DATx_DIR	SD/SDIO SDR104 mode	T_{SHKHGX}	1.7	—	ns	—
	eMMC HS200 mode					
Output delay time: SDHC_CLK to SDHC_CMD, SDHC DATx valid, SDHC_CMD_DIR, SDHC_DATx_DIR	SD/SDIO SDR104	T_{SHKHGX}	—	3.82	ns	—
	eMMC HS200 mode					
Input data window (UI)	SD/SDIO SDR104 mode	t_{SHIDV}	0.5	—	Unit interval	—
	eMMC HS200 mode					

Notes:

- $C_L = C_{BUS} + C_{HOST} + C_{CARD} \leq 10$ pF.
- For recommended operating conditions, see [Table 3](#).

This figure shows the SDR104/HS200 mode AC timing diagram.

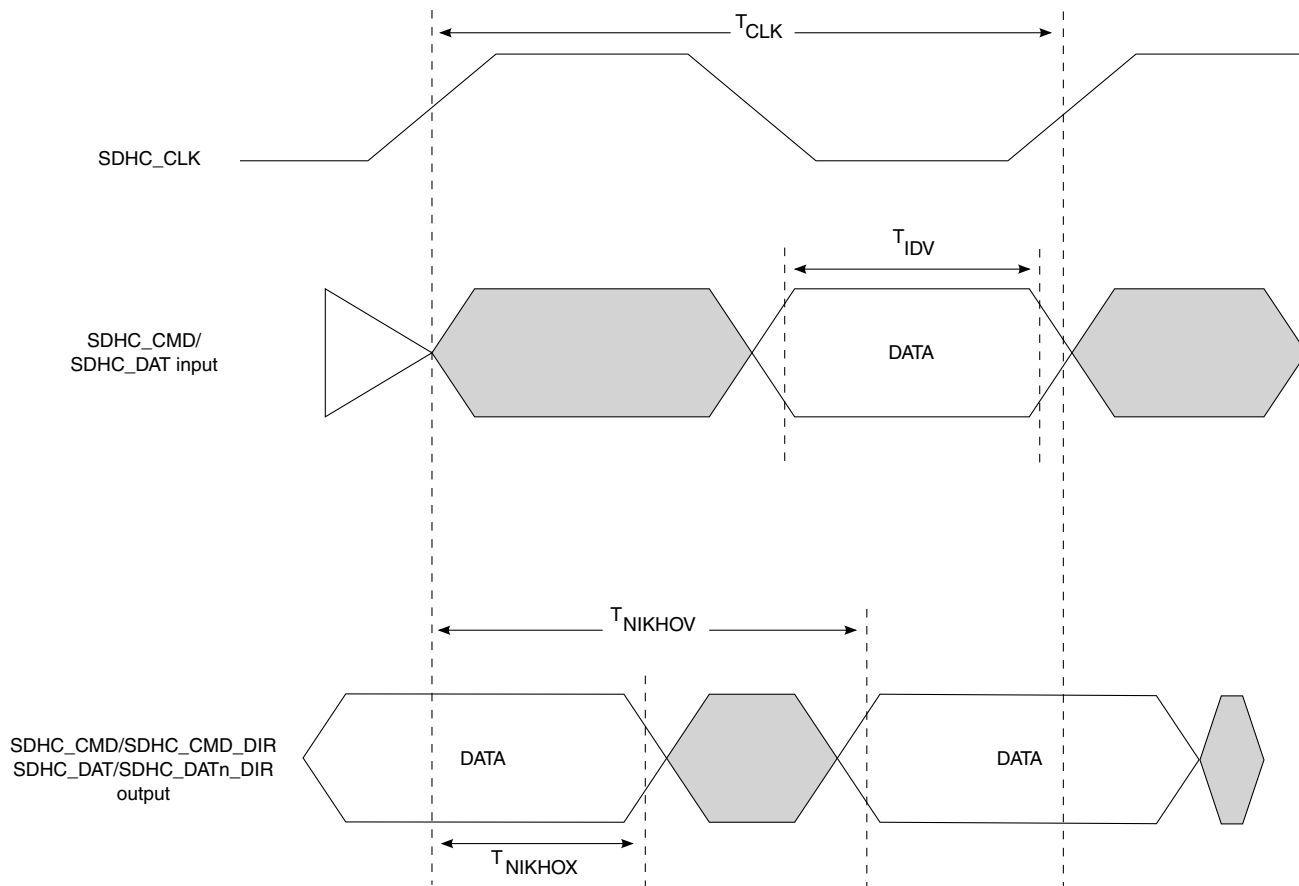

Figure 64. SDR104/eMMC HS200 mode AC timing diagram

3.23 JTAG controller

This section describes the DC and AC electrical specifications for the IEEE 1149.1 (JTAG) interface.

3.23.1 JTAG DC electrical characteristics

This table provides the JTAG DC electrical characteristics.

Table 108. JTAG DC electrical characteristics ($OV_{DD} = 1.8V$)³

Parameter	Symbol	Min	Max	Unit	Notes
Input high voltage	V_{IH}	$0.7 \times OV_{DD}$	—	V	1

Table continues on the next page...

Table 108. JTAG DC electrical characteristics ($OV_{DD} = 1.8V$)³ (continued)

Parameter	Symbol	Min	Max	Unit	Notes
Input low voltage	V_{IL}	—	$0.2 \times OV_{DD}$	V	1
Input current ($OV_{IN} = 0 V$ or $OV_{IN} = OV_{DD}$)	I_{IN}	—	± 50	μA	2
Output high voltage ($OV_{DD} = \text{min}$, $I_{OH} = -0.5 \text{ mA}$)	V_{OH}	1.35	—	V	—
Output low voltage ($OV_{DD} = \text{min}$, $I_{OL} = 0.5 \text{ mA}$)	V_{OL}	—	0.4	V	—

Notes:

1. The min V_{IL} and max V_{IH} values are based on the respective min and max OV_{IN} values found in [Table 3](#).
2. The symbol V_{IN} , in this case, represents the OV_{IN} symbol found in [Table 3](#).
3. For recommended operating conditions, see [Table 3](#).

3.23.2 JTAG AC timing specifications

This table provides the JTAG AC timing specifications as defined in [Figure 65](#), [Figure 66](#), [Figure 67](#), and [Figure 68](#).

Table 109. JTAG AC timing specifications⁴

Parameter	Symbol ¹	Min	Max	Unit	Notes	
JTAG external clock frequency of operation	f_{JTG}	0	33.3	MHz	—	
JTAG external clock cycle time	t_{JTG}	30	—	ns	—	
JTAG external clock pulse width measured at 1.4 V	t_{JTKHKL}	15	—	ns	—	
JTAG external clock rise and fall times	t_{JTGR}/t_{JTGF}	0	2	ns	—	
TRST_B assert time	t_{TRST}	25	—	ns	2	
Input setup times	t_{JTDVKH}	4	—	ns	—	
Input hold times	t_{JTDXKH}	10	—	ns	—	
Output valid times	Boundary-scan data	t_{JTKLDV}	—	15	ns	3
	TDO	—	10			
Output hold times	t_{JTKLDX}	0	—	ns	3	

Notes:

1. The symbols used for timing specifications follow these patterns: $t_{(\text{first two letters of functional block})(\text{signal})(\text{state})(\text{reference})(\text{state})}$ for inputs and $t_{(\text{first two letters of functional block})(\text{reference})(\text{state})(\text{signal})(\text{state})}$ for outputs. For example, t_{JTDVKH} symbolizes JTAG device timing (JT) with respect to the time data input signals (D) reaching the valid state (V) relative to the t_{JTG} clock reference (K) going to the high (H) state or setup time. Also, t_{JTDXKH} symbolizes JTAG timing (JT) with respect to the time data input signals (D) reaching the invalid state (X) relative to the t_{JTG} clock reference (K) going to the high (H) state. Note that, in general, the clock reference symbol representation is based on three letters representing the clock of a particular function. For rise and fall times, the latter convention is used with the appropriate letter: R (rise) or F (fall).
2. TRST_B is an asynchronous level sensitive signal. The setup time is for test purposes only.
3. All outputs are measured from the midpoint voltage of the falling edge of t_{CLK} to the midpoint of the signal in question. The output timings are measured at the pins. All output timings assume a purely resistive 50- Ω load. Time-of-flight delays must be added for trace lengths, vias, and connectors in the system.
4. For recommended operating conditions, see [Table 3](#).

This figure shows the AC test load for TDO and the boundary-scan outputs of the device.

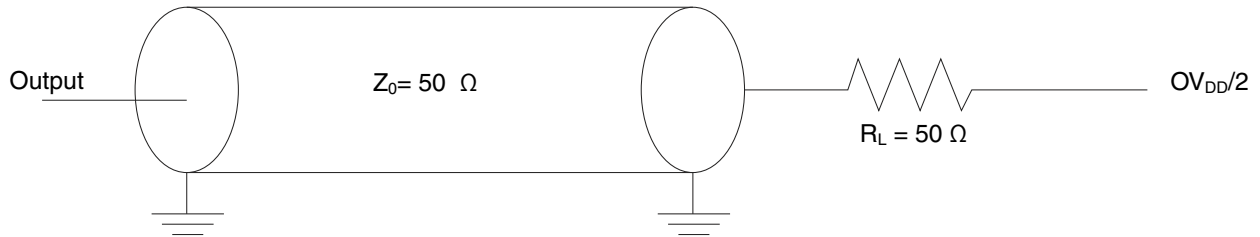

Figure 65. AC test load for the JTAG interface

This figure shows the JTAG clock input timing diagram.

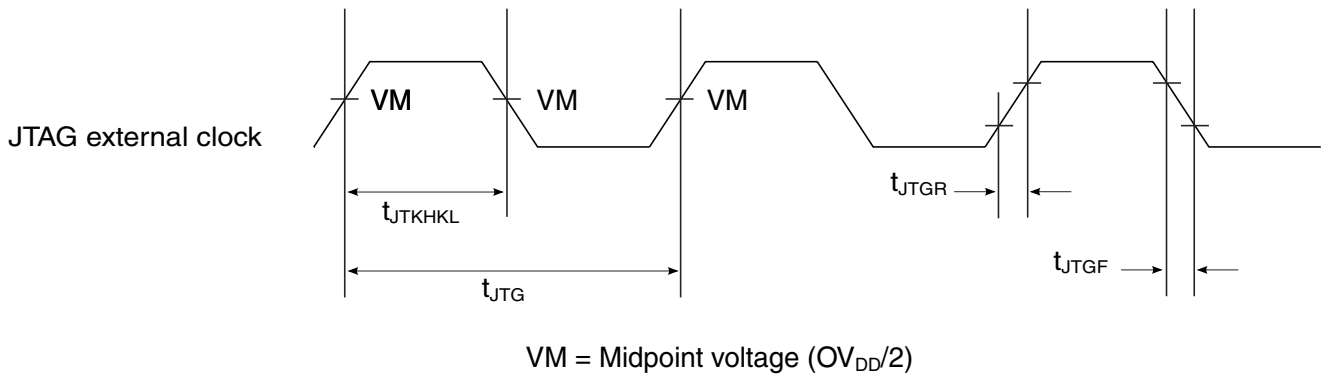

Figure 66. JTAG clock input timing diagram

This figure shows the TRST_B timing diagram.

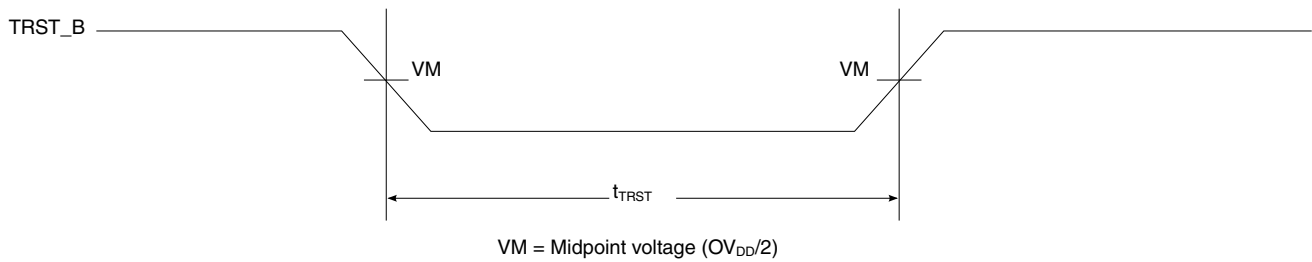

Figure 67. TRST_B timing diagram

This figure shows the boundary-scan timing diagram.

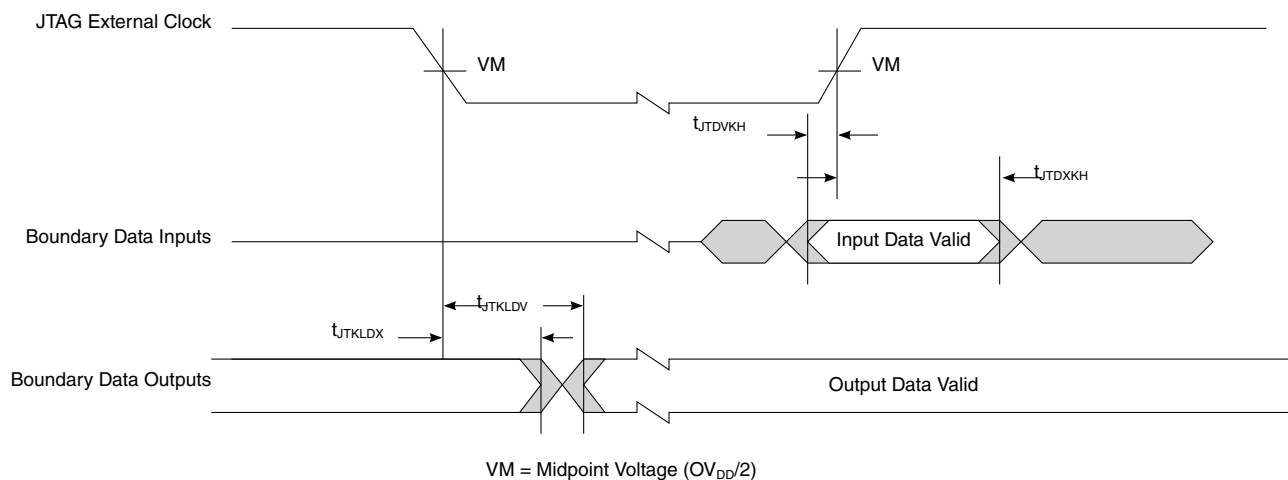

Figure 68. Boundary-scan timing diagram

3.24 I²C interface

This section describes the DC and AC electrical characteristics for the I²C interfaces.

3.24.1 I²C DC electrical characteristics

This table provides the DC electrical characteristics for the I²C1 interfaces operating at $D1V_{DD} = 3.3$ V, the I²C2 interfaces operating at $DV_{DD} = 3.3$ V, and the I²C3 interfaces operating at $BV_{DD} = 3.3$ V.

Table 110. I²C DC electrical characteristics (DV_{DD} , $D1V_{DD} = 3.3$ V)⁴

Parameter	Symbol	Min	Max	Unit	Notes
Input high voltage	V_{IH}	$0.7 \times nV_{DD}$	—	V	1
Input low voltage	V_{IL}	—	$0.2 \times nV_{DD}$	V	1
Output low voltage ($DV_{DD} = \text{min}$, $I_{OL} = 3$ mA)	V_{OL}	—	0.4	V	—
Pulse width of spikes which must be suppressed by the input filter	t_{i2KHKL}	0	50	ns	2
Input current each I/O pin (input voltage is between $0.1 \times DV_{DD}$ and $0.9 \times DV_{DD}(\text{max})$)	I_I	-50	50	μA	3
Capacitance for each I/O pin	C_I	—	10	pF	—

Notes:

- The min V_{IL} and max V_{IH} values are based on the respective min and max DV_{IN} values found in [Table 3](#).

Table 110. I²C DC electrical characteristics (DV_{DD}, D1V_{DD} = 3.3 V)⁴

Parameter	Symbol	Min	Max	Unit	Notes
2. See the chip reference manual for information about the digital filter used.					
3. I/O pins obstruct the SDA and SCL lines if DV _{DD} is switched off.					
4. For recommended operating conditions, see Table 3 .					

This table provides the DC electrical characteristics for the I²C1 interfaces operating at D1V_{DD} = 1.8 V, the I²C2 interfaces operating at DV_{DD} = 1.8 V, and the I²C3 interfaces operating at BV_{DD} = 1.8 V.

Table 111. I²C DC electrical characteristics (DV_{DD}, D1V_{DD} = 1.8 V)⁴

Parameter	Symbol	Min	Max	Unit	Notes
Input high voltage	V _{IH}	0.7 x nV _{DD}	—	V	1
Input low voltage	V _{IL}	—	0.2 x nV _{DD}	V	1
Output low voltage (DV _{DD} = min, I _{OL} = 2 mA)	V _{OL}	0	0.2 x nV _{DD}	V	—
Pulse width of spikes which must be suppressed by the input filter	t _{12KHKL}	0	50	ns	2
Input current each I/O pin (input voltage is between 0.1 x DV _{DD} and 0.9 x DV _{DD} (max))	I _I	-50	50	μA	3
Capacitance for each I/O pin	C _I	—	10	pF	—
Notes:					
1. The min V _{IL} and max V _{IH} values are based on the respective min and max DV _{IN} values found in Table 3 .					
2. See the chip reference manual for information about the digital filter used.					
3. I/O pins obstruct the SDA and SCL lines if DV _{DD} is switched off.					
4. For recommended operating conditions, see Table 3 .					

3.24.2 I²C AC timing specifications

This table provides the AC timing specifications for the I²C interfaces.

Table 112. I²C AC timing specifications⁵

Parameter	Symbol ¹	Min	Max	Unit	Notes
SCL clock frequency	f _{I2C}	0	400	kHz	2
Low period of the SCL clock	t _{12CL}	1.3	—	μs	—
High period of the SCL clock	t _{12CH}	0.6	—	μs	—
Setup time for a repeated START condition	t _{12SVKH}	0.6	—	μs	—
Hold time (repeated) START condition (after this period, the first clock pulse is generated)	t _{12SXKL}	0.6	—	μs	—

Table continues on the next page...

Table 112. I²C AC timing specifications⁵ (continued)

Parameter	Symbol ¹	Min	Max	Unit	Notes
Data setup time	t_{I2DVKH}	100	—	ns	—
Data input hold time	CBUS compatible masters	—	—	μ s	3
	I ² C bus devices	0	—		
Data output delay time	t_{I2OVKL}	—	0.9	μ s	4
Setup time for STOP condition	t_{I2PVKH}	0.6	—	μ s	—
Bus free time between a STOP and START condition	t_{I2KHDX}	1.3	—	μ s	—
Noise margin at the LOW level for each connected device	V_{NL}	$0.1 \times DV_{DD}$	—	V	—
Noise margin at the HIGH level for each connected device	V_{NH}	$0.2 \times DV_{DD}$	—	V	—
Capacitive load for each bus line	C_b	—	400	pF	—

Notes:

1. The symbols used for timing specifications herein follow these patterns: $t_{(\text{first two letters of functional block})(\text{signal})(\text{state})(\text{reference})(\text{state})}$ for inputs and $t_{(\text{first two letters of functional block})(\text{reference})(\text{state})(\text{signal})(\text{state})}$ for outputs. For example, t_{I2DVKH} symbolizes I²C timing (I2) with respect to the time data input signals (D) reaching the valid state (V) relative to the t_{I2C} clock reference (K) going to the high (H) state or setup time. Also, t_{I2SXKL} symbolizes I²C timing (I2) for the time that the data with respect to the START condition (S) went invalid (X) relative to the t_{I2C} clock reference (K) going to the low (L) state or hold time. Also, t_{I2PVKH} symbolizes I²C timing (I2) for the time that the data with respect to the STOP condition (P) reaches the valid state (V) relative to the t_{I2C} clock reference (K) going to the high (H) state or setup time.

2. The requirements for I²C frequency calculation must be followed. See *Determining the I²C Frequency Divider Ratio for SCL* (AN2919).

3. As a transmitter, the chip provides a delay time of at least 300 ns for the SDA signal (referred to the V_{IHmin} of the SCL signal) to bridge the undefined region of the falling edge of SCL to avoid unintended generation of a START or STOP condition. When the chip acts as the I²C bus master while transmitting, it drives both SCL and SDA. As long as the load on SCL and SDA are balanced, the chip does not generate an unintended START or STOP condition. Therefore, the 300 ns SDA output delay time is not a concern. If, under some rare condition, the 300 ns SDA output delay time is required for the chip as transmitter, see *Determining the I²C Frequency Divider Ratio for SCL* (AN2919).

4. The maximum t_{I2OVKL} has to be met only if the device does not stretch the LOW period (t_{I2CL}) of the SCL signal.

5. For recommended operating conditions, see Table 3.

This figure shows the AC test load for the I²C.

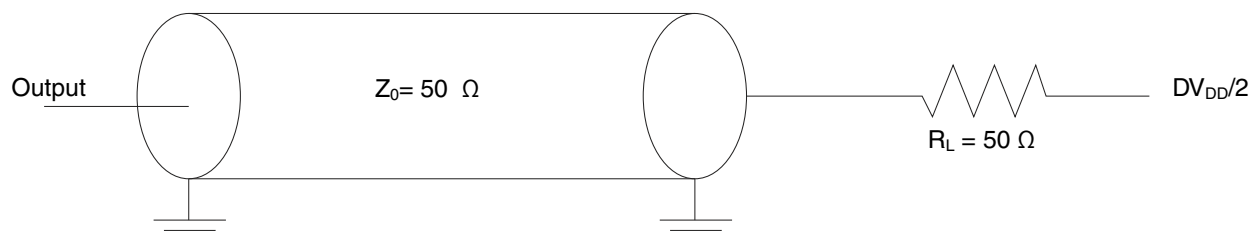
Figure 69. I²C AC test load

This figure shows the AC timing diagram for the I²C bus.

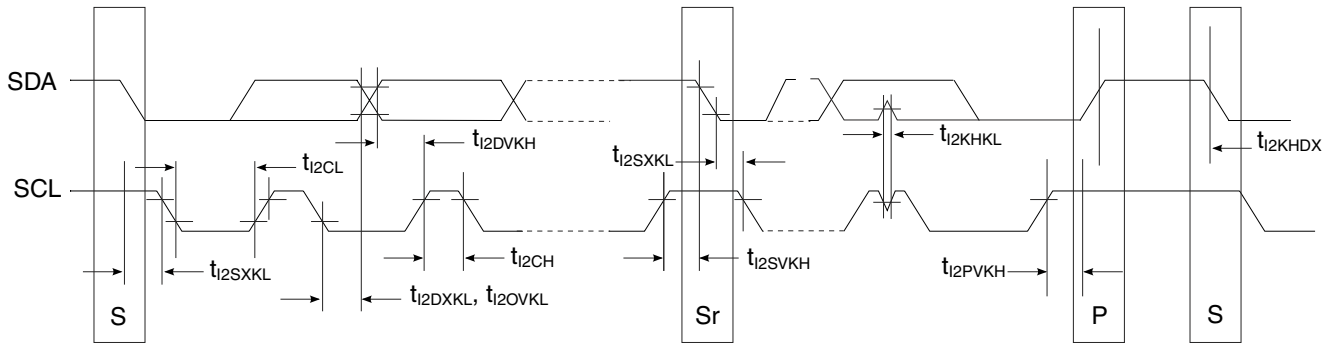

Figure 70. I²C bus AC timing diagram

3.25 GPIO interface

This section describes the DC and AC electrical characteristics for the GPIO interface. There are GPIO pins on various power supplies in this device. In this section, LV_{IN} and LV_{DD} stands for any power supply that the GPIO is running off.

3.25.1 GPIO DC electrical characteristics

This table provides the DC electrical characteristics for GPIO pins operating at $L/L1/D/D1/O/O1/E/BV_{DD} = 3.3\text{ V}$.

Table 113. GPIO DC electrical characteristics (3.3 V)³

Parameter	Symbol	Min	Max	Unit	Notes
Input high voltage	V_{IH}	$0.7 \times nV_{DD}$	—	V	1
Input low voltage	V_{IL}	—	$0.2 \times nV_{DD}$	V	1
Input current ($V_{IN} = 0\text{ V}$ or $V_{IN} = LV_{DD}$)	I_{IN}	—	± 50	μA	2
Output high voltage ($LV_{DD} = \text{min}$, $I_{OH} = -2\text{ mA}$)	V_{OH}	2.4	—	V	—
Output low voltage ($LV_{DD} = \text{min}$, $I_{OL} = 2\text{ mA}$)	V_{OL}	—	0.4	V	—

Notes:

1. The min V_{IL} and max V_{IH} values are based on the respective min and max LV_{IN} values found in Table 3.
2. The symbol V_{IN} , in this case, represents the LV_{IN} symbol referenced in Table 3.
3. For recommended operating conditions, see Table 3.

This table provides the DC electrical characteristics for GPIO pins operating at $LV_{DD}/L1V_{DD} = 2.5\text{ V}$.

Table 114. GPIO DC electrical characteristics (2.5 V)³

Parameter	Symbol	Min	Max	Unit	Notes
Input high voltage	V_{IH}	$0.7 \times nV_{DD}$	—	V	1
Input low voltage	V_{IL}	—	$0.2 \times nV_{DD}$	V	1
Input current ($V_{IN} = 0$ V or $V_{IN} = LV_{DD}/L1V_{DD}$)	I_{IN}	—	± 50	μ A	2
Output high voltage ($LV_{DD}/L1V_{DD} = \text{min}$, $I_{OH} = -1$ mA)	V_{OH}	2.0	—	V	—
Output low voltage ($LV_{DD}/L1V_{DD} = \text{min}$, $I_{OL} = 1$ mA)	V_{OL}	—	0.4	V	—

Notes:

1. The min V_{IL} and max V_{IH} values are based on the respective min and max $LV_{IN}/L1V_{IN}$ values found in [Table 3](#).
2. The symbol V_{IN} , in this case, represents the $LV_{IN}/L1V_{IN}$ symbol referenced in [Table 3](#).
3. For recommended operating conditions, see [Table 3](#).

This table provides the DC electrical characteristics for GPIO pins operating at $L/L1/D/D1/O/O1/E/BV_{DD} = 1.8$ V.

Table 115. GPIO DC electrical characteristics (1.8 V)³

Parameter	Symbol	Min	Max	Unit	Notes
Input high voltage	V_{IH}	$0.7 \times nV_{DD}$	—	V	1
Input low voltage	V_{IL}	—	$0.2 \times nV_{DD}$	V	1
Input current ($V_{IN} = 0$ V or $V_{IN} = LV_{DD}$)	I_{IN}	—	± 50	μ A	2
Output high voltage ($LV_{DD} = \text{min}$, $I_{OH} = -0.5$ mA)	V_{OH}	1.35	—	V	—
Output low voltage ($LV_{DD} = \text{min}$, $I_{OL} = 0.5$ mA)	V_{OL}	—	0.4	V	—

Notes:

1. The min V_{IL} and max V_{IH} values are based on the respective min and max LV_{IN} values found in [Table 3](#).
2. The symbol V_{IN} , in this case, represents the LV_{IN} symbol referenced in [Table 3](#).
3. For recommended operating conditions, see [Table 3](#).

3.25.2 GPIO AC timing specifications

This table provides the GPIO input and output AC timing specifications.

Table 116. GPIO input AC timing specifications

Parameter	Symbol	Min	Unit	Notes
GPIO inputs—minimum pulse width	t_{PIWID}	20	ns	1, 2, 3
Note: 1. GPIO inputs and outputs are asynchronous to any visible clock. GPIO outputs should be synchronized before use by any external synchronous logic. GPIO inputs are required to be valid for at least t_{PIWID} to ensure proper operation. 2. For recommended operating conditions, see Table 3 . 3. Entry and exit from deep sleep respectively require a minimum pulse width t_{PIWID} of 35 SYSCLK. See the Reference Manual for details on Entry and Exit from deep sleep.				

This figure shows the AC test load for the GPIO.

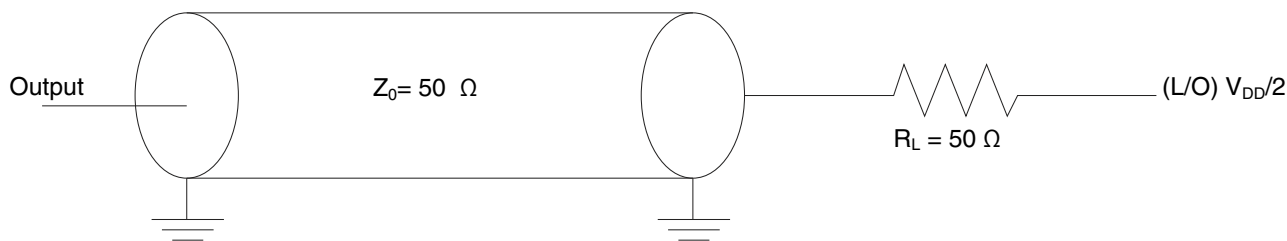

Figure 71. GPIO AC test load

3.26 GIC interface

This section describes the DC and AC electrical characteristics for the GIC interface.

3.26.1 GIC DC electrical characteristics

This table provides the DC electrical characteristics for GIC pins operating at $L/L1/D/D1/O/O1/E/BV_{DD} = 3.3\text{ V}$.

Table 117. GIC DC electrical characteristics (3.3 V)³

Parameter	Symbol	Min	Max	Unit	Notes
Input high voltage	V_{IH}	$0.7 \times nV_{DD}$	—	V	1
Input low voltage	V_{IL}	—	$0.2 \times nV_{DD}$	V	1
Input current ($V_{IN} = 0\text{ V}$ or $V_{IN} = LV_{DD}$)	I_{IN}	—	± 50	μA	2
Output high voltage ($LV_{DD} = \text{min}$, $I_{OH} = -2\text{ mA}$)	V_{OH}	2.4	—	V	—
Output low voltage	V_{OL}	—	0.4	V	—

Table continues on the next page...

Table 117. GIC DC electrical characteristics (3.3 V)³ (continued)

Parameter	Symbol	Min	Max	Unit	Notes
(LV _{DD} = min, I _{OL} = 2 mA)					
Notes:					
1. The min V _{IL} and max V _{IH} values are based on the respective min and max LV _{IN} values found in Table 3 .					
2. The symbol V _{IN} , in this case, represents the LV _{IN} symbol referenced in Table 3 .					
3. For recommended operating conditions, see Table 3 .					

This table provides the DC electrical characteristics for GIC pins operating at LV_{DD}/L1V_{DD} = 2.5 V.

Table 118. GIC DC electrical characteristics (2.5 V)³

Parameter	Symbol	Min	Max	Unit	Notes
Input high voltage	V _{IH}	0.7 x nV _{DD}	—	V	1
Input low voltage	V _{IL}	—	0.2 x nV _{DD}	V	1
Input current (V _{IN} = 0 V or V _{IN} = LV _{DD} /L1V _{DD})	I _{IN}	—	±50	µA	2
Output high voltage (LV _{DD} /L1V _{DD} = min, I _{OH} = -1 mA)	V _{OH}	2.0	—	V	—
Output low voltage (LV _{DD} /L1V _{DD} = min, I _{OL} = 1 mA)	V _{OL}	—	0.4	V	—
Notes:					
1. The min V _{IL} and max V _{IH} values are based on the respective min and max LV _{IN} /L1V _{IN} values found in Table 3 .					
2. The symbol V _{IN} , in this case, represents the LV _{IN} /L1V _{IN} symbol referenced in Table 3 .					
3. For recommended operating conditions, see Table 3 .					

This table provides the DC electrical characteristics for GIC pins operating at L/L1/D/D1/O/O1/E/BV_{DD} = 1.8 V.

Table 119. GIC DC electrical characteristics (1.8 V)³

Parameter	Symbol	Min	Max	Unit	Notes
Input high voltage	V _{IH}	0.7 x nV _{DD}	—	V	1
Input low voltage	V _{IL}	—	0.2 x nV _{DD}	V	1
Input current (V _{IN} = 0 V or V _{IN} = LV _{DD})	I _{IN}	—	±50	µA	2
Output high voltage (LV _{DD} = min, I _{OH} = -0.5 mA)	V _{OH}	1.35	—	V	—
Output low voltage (LV _{DD} = min, I _{OL} = 0.5 mA)	V _{OL}	—	0.4	V	—
Notes:					
1. The min V _{IL} and max V _{IH} values are based on the respective min and max LV _{IN} values found in Table 3 .					

Table 119. GIC DC electrical characteristics (1.8 V)³

Parameter	Symbol	Min	Max	Unit	Notes
2. The symbol V_{IN} , in this case, represents the LV_{IN} symbol referenced in Table 3 .					
3. For recommended operating conditions, see Table 3 .					

3.26.2 GIC AC timing specifications

This table provides the GIC input and output AC timing specifications.

Table 120. GIC Input AC timing specifications²

Characteristic	Symbol	Min	Max	Unit	Notes
GIC inputs-minimum pulse width	t_{PIWID}	3	-	SYCLKs	1, 3
1. GIC inputs and outputs are asynchronous to any visible clock. GIC outputs must be synchronized before use by any external synchronous logic. GIC inputs are required to be valid for at least t_{PIWID} ns to ensure proper operation when working in edge triggered mode.					
2. For recommended operating conditions, see Table 3 .					
3. Entry and exit from deep sleep respectively require a minimum pulse width t_{PIWID} of 25 SYCLK. See the applicable device reference manual for details on Entry and Exit from deep sleep.					

3.27 High-speed serial interfaces (HSSI)

The chip features a Serializer/Deserializer (SerDes) interface to be used for high-speed serial interconnect applications. The SerDes interface can be used for PCI Express, SGMII, and serial ATA (SATA) data transfers.

This section describes the most common portion of the SerDes DC electrical specifications: the DC requirement for SerDes reference clocks. The SerDes data lane's transmitter (Tx) and receiver (Rx) reference circuits are also described.

3.27.1 Signal terms definitions

The SerDes utilizes differential signaling to transfer data across the serial link. This section defines the terms that are used in the description and specification of differential signals.

This figure shows how the signals are defined. For illustration purposes only, one SerDes lane is used in the description. This figure shows the waveform for either a transmitter output (SD_TXn_P and SD_TXn_N) or a receiver input (SD_RXn_P and SD_RXn_N). Each signal swings between A volts and B volts where $A > B$.

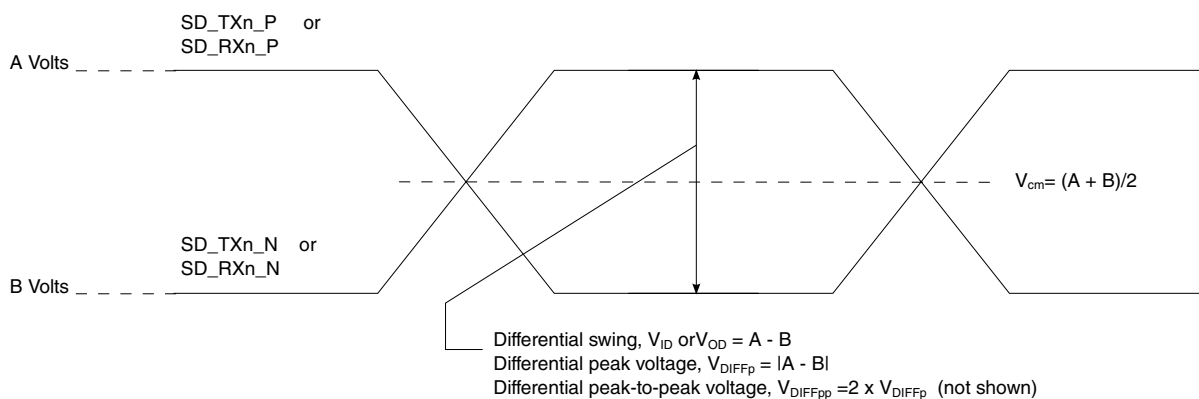

Figure 72. Differential voltage definitions for transmitter or receiver

Using this waveform, the definitions are as described in the following list. To simplify the illustration, the definitions assume that the SerDes transmitter and receiver operate in a fully symmetrical differential signaling environment:

Single-Ended Swing

The transmitter output signals and the receiver input signals SD_TXn_P, SD_TXn_N, SD_RXn_P and SD_RXn_N each have a peak-to-peak swing of A - B volts. This is also referred to as each signal wire's single-ended swing.

Differential Output Voltage, V_{OD} (or Differential Output Swing)

The differential output voltage (or swing) of the transmitter, V_{OD} , is defined as the difference of the two complementary output voltages: $V_{SD_TXn_P} - V_{SD_TXn_N}$. The V_{OD} value can be either positive or negative.

Differential Input Voltage, V_{ID} (or Differential Input Swing)

The differential input voltage (or swing) of the receiver, V_{ID} , is defined as the difference of the two complementary input voltages: $V_{SD_RXn_P} - V_{SD_RXn_N}$. The V_{ID} value can be either positive or negative.

Differential Peak Voltage, V_{DIFFp}

The peak value of the differential transmitter output signal or the differential receiver input signal is defined as the differential peak voltage, $V_{DIFFp} = |A - B|$ volts.

Differential Peak-to-Peak, $V_{DIFFp-p}$

Because the differential output signal of the transmitter and the differential input signal of the receiver each range from A - B to -(A - B) volts, the peak-to-peak value of the differential transmitter output signal or the differential receiver input signal is defined as differential peak-to-peak voltage, $V_{DIFFp-p} = 2 \times V_{DIFFp} = 2 \times |A - B|$ volts, which is twice the differential swing in amplitude, or twice the differential peak. For example, the output differential peak-to-peak voltage can also be calculated as $V_{TX-DIFFp-p} = 2 \times |V_{OD}|$.

Differential Waveform

The differential waveform is constructed by subtracting the inverting signal (SD_TXn_N, for example) from the non-inverting signal (SD_TXn_P, for example)

within a differential pair. There is only one signal trace curve in a differential waveform. The voltage represented in the differential waveform is not referenced to ground. See [Figure 77](#) as an example for differential waveform.

Common Mode Voltage, V_{cm}

The common mode voltage is equal to half of the sum of the voltages between each conductor of a balanced interchange circuit and ground. In this example, for SerDes output, $V_{cm_out} = (V_{SD_TXn_P} + V_{SD_TXn_N}) \div 2 = (A + B) \div 2$, which is the arithmetic mean of the two complementary output voltages within a differential pair. In a system, the common mode voltage may often differ from one component's output to the other's input. It may be different between the receiver input and driver output circuits within the same component. It is also referred to as the DC offset on some occasions.

To illustrate these definitions using real values, consider the example of a current mode logic (CML) transmitter that has a common mode voltage of 2.25 V and outputs, TD and TD_B. If these outputs have a swing from 2.0 V to 2.5 V, the peak-to-peak voltage swing of each signal (TD or TD_B) is 500 mV p-p, which is referred to as the single-ended swing for each signal. Because the differential signaling environment is fully symmetrical in this example, the transmitter output's differential swing (V_{OD}) has the same amplitude as each signal's single-ended swing. The differential output signal ranges between 500 mV and -500 mV. In other words, V_{OD} is 500 mV in one phase and -500 mV in the other phase. The peak differential voltage (V_{DIFFp}) is 500 mV. The peak-to-peak differential voltage ($V_{DIFFp-p}$) is 1000 mV p-p.

3.27.2 SerDes reference clocks

The SerDes reference clock inputs are applied to an internal phase-locked loop (PLL) whose output creates the clock used by the corresponding SerDes lanes. The SerDes reference clocks inputs are SD1_REF_CLK[1:2]_P and SD1_REF_CLK[1:2]_N.

SerDes may be used for various combinations of the following IP blocks based on the RCW Configuration field SRDS_PRTCLn:

- SGMII (1.25 Gbps)
- PCIe (2.5 and 5 Gbps)
- SATA (1.5, 3.0, and 6.0 Gbps)

The following sections describe the SerDes reference clock requirements and provide application information.

3.27.2.1 SerDes spread-spectrum clock source recommendations

SD1_REF_CLK n _P and SD1_REF_CLK n _N are designed to work with spread-spectrum clocking for the PCI Express protocol only with the spreading specification defined in [Table 121](#). When using spread-spectrum clocking for PCI Express, both ends of the link partners should use the same reference clock. For best results, a source without significant unintended modulation must be used.

The SerDes transmitter does not support spread-spectrum clocking for the SATA protocol. The SerDes receiver does support spread-spectrum clocking on receive, which means the SerDes receiver can receive data correctly from a SATA serial link partner using spread-spectrum clocking.

Spread-spectrum clocking cannot be used if the same SerDes reference clock is shared with other non-spread-spectrum-supported protocols. For example, if spread-spectrum clocking is desired on a SerDes reference clock for the PCI Express protocol and the same reference clock is used for any other protocol, such as SATA or SGMII because of the SerDes lane usage mapping option, spread-spectrum clocking cannot be used at all.

This table provides the source recommendations for SerDes spread-spectrum clocking.

Table 121. SerDes spread-spectrum clock source recommendations ¹

Parameter	Min	Max	Unit	Notes
Frequency modulation	30	33	kHz	—
Frequency spread	+0	-0.5	%	2
Notes:				
1. At recommended operating conditions. See Table 3 .				
2. Only down-spreading is allowed.				

3.27.2.2 SerDes reference clock receiver characteristics

This figure shows a receiver reference diagram of the SerDes reference clocks.



Figure 73. Receiver of SerDes reference clocks

The characteristics of the clock signals are as follows:

- The SerDes transceiver's core power supply voltage requirements (SV_{DDn}) are as specified in [Table 3](#).
- The SerDes reference clock receiver reference circuit structure is as follows:
 - The SD1_REF_CLKn_P and SD1_REF_CLKn_N are internally AC-coupled differential inputs as shown in [Figure 73](#). Each differential clock input (SD1_REF_CLKn_P or SD1_REF_CLKn_N) has on-chip 50- Ω termination to SGNDn followed by on-chip AC-coupling.
 - The external reference clock driver must be able to drive this termination.
 - The SerDes reference clock input can be either differential or single-ended. See the differential mode and single-ended mode descriptions in [Signal terms definitions](#) for detailed requirements.
- The maximum average current requirement also determines the common mode voltage range.
 - When the SerDes reference clock differential inputs are DC coupled externally with the clock driver chip, the maximum average current allowed for each input pin is 8 mA. In this case, the exact common mode input voltage is not critical as long as it is within the range allowed by the maximum average current of 8 mA because the input is AC-coupled on-chip.
 - This current limitation sets the maximum common mode input voltage to be less than 0.4 V ($0.4\text{ V} \div 50 = 8\text{ mA}$) while the minimum common mode input level is 0.1 V above SGNDn. For example, a clock with a 50/50 duty cycle can be produced by a clock driver with output driven by its current source from 0 mA to 16 mA (0-0.8 V), such that each phase of the differential input has a single-ended swing from 0 V to 800 mV with the common mode voltage at 400 mV.
 - If the device driving the SD1_REF_CLKn_P and SD1_REF_CLKn_N inputs cannot drive 50 Ω to SGNDn DC or the drive strength of the clock driver chip exceeds the maximum input current limitations, it must be AC-coupled off-chip.
- The input amplitude requirement is described in detail in the following sections.

3.27.2.3 DC-level requirements for SerDes reference clocks

The DC-level requirements for the SerDes reference clock inputs are different depending on the signaling mode used to connect the clock driver chip and SerDes reference clock inputs, as described below:

- Differential Mode
 - The input amplitude of the differential clock must be between 400 mV and 1600 mV differential peak-to-peak (or between 200 mV and 800 mV differential peak). In other words, each signal wire of the differential pair must have a single-ended swing of less than 800 mV and greater than 200 mV. This requirement is the same for both external DC-coupled or AC-coupled connection.
 - For an external DC-coupled connection, as described in [Figure 73](#), the maximum average current requirements set the requirement for average voltage (common mode voltage) as between 100 mV and 400 mV.
 - This figure shows the SerDes reference clock input requirement for a DC-coupled connection scheme.

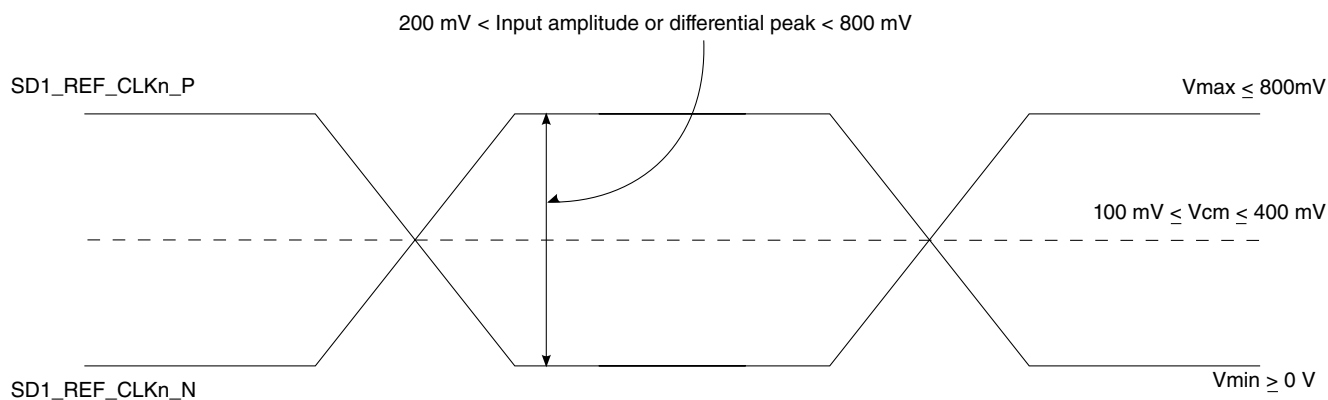

Figure 74. Differential reference clock input DC requirements (external DC-coupled)

- For an external AC-coupled connection, there is no common mode voltage requirement for the clock driver. Because the external AC-coupling capacitor blocks the DC level, the clock driver and the SerDes reference clock receiver operate in different common mode voltages. The SerDes reference clock receiver in this connection scheme has its common mode voltage set to SGNDn. Each signal wire of the differential inputs is allowed to swing below and above the common mode voltage (SGNDn).
- This figure shows the SerDes reference clock input requirement for an AC-coupled connection scheme.



Figure 75. Differential reference clock input DC requirements (external AC-coupled)

- Single-ended mode
 - The reference clock can also be single-ended. The SD1_REF_CLKn_P input amplitude (single-ended swing) must be between 400 mV and 800 mV peak-to-peak (from V_{MIN} to V_{MAX}) with SD1_REF_CLKn_N either left unconnected or tied to ground.
 - To meet the input amplitude requirement, the reference clock inputs may need to be externally DC- or AC-coupled. For the best noise performance, the reference of the clock could be DC- or AC-coupled into the unused phase (SD1_REF_CLKn_N) through the same source impedance as the clock input (SD1_REF_CLKn_P) in use.
 - The SD1_REF_CLKn_P input average voltage must be between 200 and 400 mV.
 - This figure shows the SerDes reference clock input requirement for single-ended signaling mode.

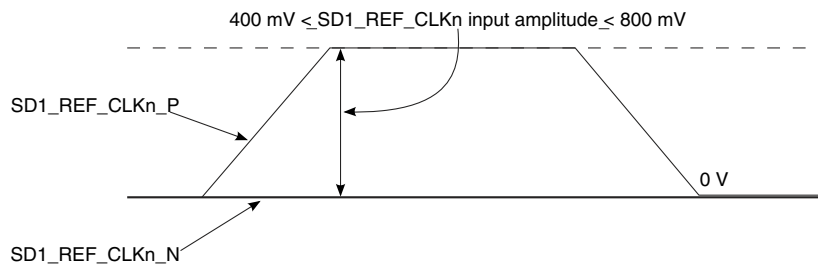

Figure 76. Single-ended reference clock input DC requirements

3.27.2.4 AC requirements for SerDes reference clocks

This table provides the AC requirements for SerDes reference clocks for protocols running at data rates up to 5 Gb/s.

This includes PCI Express (2.5 and 5 GT/s), SGMII (1.25 Gbps), and SATA (1.5, 3.0, and 6.0 Gbps). SerDes reference clocks need to be verified by the customer's application design.

Table 122. SD1_REF_CLKn_P and SD1_REF_CLKn_N input clock requirements (S1V_{DDn} = 1.0 V) ¹

Parameter	Symbol	Min	Typ	Max	Unit	Notes
SD1_REF_CLKn_P/SD1_REF_CLKn_N frequency range	t _{CLK_REF}	—	100/125	—	MHz	2
SD1_REF_CLKn_P/SD1_REF_CLKn_N clock frequency tolerance	t _{CLK_TOL}	-300	—	300	ppm	3
SD1_REF_CLKn_P/SD1_REF_CLKn_N clock frequency tolerance	t _{CLK_TOL}	-100	—	100	ppm	4
SD1_REF_CLKn_P/SD1_REF_CLKn_N reference clock duty cycle	t _{CLK_DUTY}	40	50	60	%	5
SD1_REF_CLKn_P/SD1_REF_CLKn_N max deterministic peak-to-peak jitter at 10 ⁻⁶ BER	t _{CLK_DJ}	—	—	42	ps	—
SD1_REF_CLKn_P/SD1_REF_CLKn_N total reference clock jitter at 10 ⁻⁶ BER (peak-to-peak jitter at refClk input)	t _{CLK_TJ}	—	—	86	ps	6
SD1_REF_CLKn_P/SD1_REF_CLKn_N 10 kHz to 1.5 MHz RMS jitter	t _{REFCLK-LF-RMS}	—	—	3	ps RMS	7
SD1_REF_CLKn_P/SD1_REF_CLKn_N > 1.5 MHz to Nyquist RMS jitter	t _{REFCLK-HF-RMS}	—	—	3.1	ps RMS	7
SD1_REF_CLKn_P/SD1_REF_CLKn_N rising/falling edge rate	t _{CLKRRR} /t _{CLKFR}	1	—	4	V/ns	9
Differential input high voltage	V _{IH}	200	—	—	mV	5
Differential input low voltage	V _{IL}	—	—	-200	mV	5
Rising edge rate (SD1_REF_CLKn_P) to falling edge rate (SD1_REF_CLKn_N) matching	Rise-Fall Matching	—	—	20	%	10, 11

Notes:

- For recommended operating conditions, see [Table 3](#).
- Caution:** Only 100 and 125 have been tested. In-between values do not work correctly with the rest of the system.
- For PCI Express (2.5 and 5 GT/s).
- For SGMII.
- Measurement taken from differential waveform.
- Limits from PCI Express CEM Rev 2.0.
- For PCI Express 5 GT/s, per PCI Express base specification Rev 3.0.
- Measured from -200 mV to +200 mV on the differential waveform (derived from SD1_REF_CLKn_P minus SD1_REF_CLKn_N). The signal must be monotonic through the measurement region for rise and fall time. The 400 mV measurement window is centered on the differential zero crossing. See [Figure 77](#).
- Measurement taken from single-ended waveform.
- Matching applies to rising edge for SD1_REF_CLKn_P and falling edge rate for SD1_REF_CLKn_N. It is measured using a 200 mV window centered on the median cross point where SD1_REF_CLKn_P rising meets SD1_REF_CLKn_N falling. The median cross point is used to calculate the voltage thresholds that the oscilloscope uses for the edge rate calculations. The rise edge rate of SD1_REF_CLKn_P must be compared to the fall edge rate of SD1_REF_CLKn_N, the maximum allowed difference should not exceed 20% of the slowest edge rate. See [Figure 78](#).

This figure shows the differential measurement points for rise and fall time.

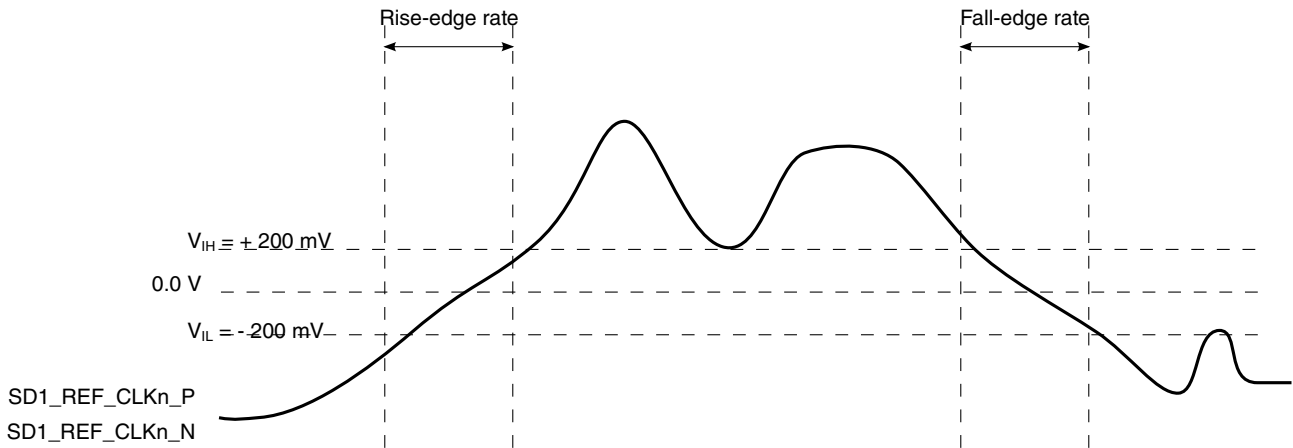

Figure 77. Differential measurement points for rise and fall time

This figure shows the single-ended measurement points for rise and fall time matching.

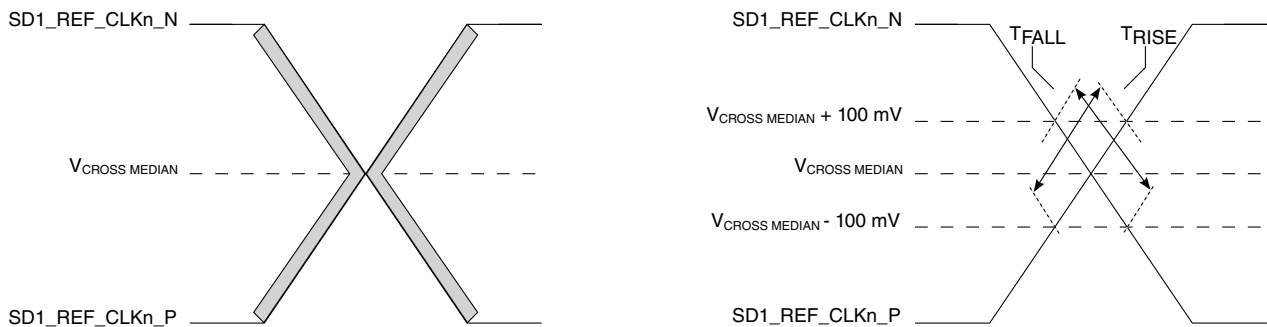

Figure 78. Single-ended measurement points for rise and fall time matching

3.27.3 SerDes transmitter and receiver reference circuits

This figure shows the reference circuits for SerDes data lane's transmitter and receiver.

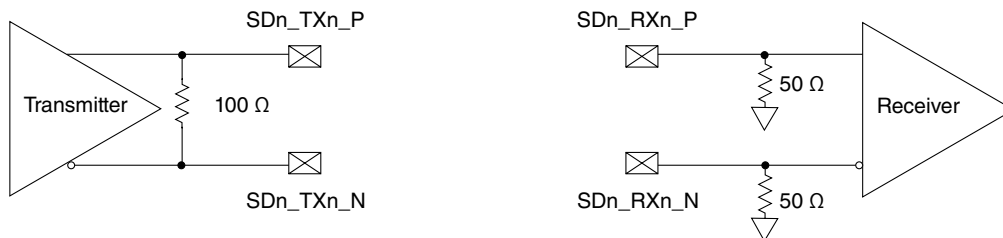

Figure 79. SerDes transmitter and receiver reference circuits

The DC and AC specifications of the SerDes data lanes are defined in each interface protocol section below based on the application usage:

- [PCI Express](#)
- [Serial ATA \(SATA\) interface](#)
- [SGMII interface](#)

Note that an external AC-coupling capacitor is required for the above serial transmission protocols with the capacitor value defined in the specification of each protocol section.

3.27.4 PCI Express

This section describes the clocking dependencies, as well as the DC and AC electrical specifications for the PCI Express bus.

3.27.4.1 Clocking dependencies

The ports on the two ends of a link must transmit data at a rate that is within 600 ppm of each other at all times. This is specified to allow bit rate clock sources with a ± 300 ppm tolerance.

3.27.4.2 PCI Express DC physical layer specifications

This section contains the DC specifications for the physical layer of PCI Express on this chip.

3.27.4.2.1 PCI Express DC physical layer transmitter specifications

This section describes the PCI Express DC physical layer transmitter specifications for 2.5 GT/s and 5 GT/s.

This table provides the PCI Express 2.0 (2.5 GT/s) DC specifications for the differential output at all transmitters. The parameters are specified at the component pins.

Table 123. PCI Express 2.0 (2.5 GT/s) differential transmitter output DC specifications (X1V_{DD} = 1.35 V)¹

Parameter	Symbol	Min	Typical	Max	Units	Notes
Differential peak-to-peak output voltage	V _{TX-DIFF-P-P}	800	1000	1200	mV	2
De-emphasized differential output voltage (ratio)	V _{TX-DE-RATIO}	3.0	3.5	4.0	dB	3
DC differential transmitter impedance	Z _{TX-DIFF-DC}	80	100	120	Ω	4
Transmitter DC impedance	Z _{TX-DC}	40	50	60	Ω	5

Notes:

Table 123. PCI Express 2.0 (2.5 GT/s) differential transmitter output DC specifications (X1V_{DD} = 1.35 V)¹

Parameter	Symbol	Min	Typical	Max	Units	Notes
1. For recommended operating conditions, see Table 3 .						
2. $V_{TX-DIFFp-p} = 2 \times V_{TX-D+} - V_{TX-D-} $						
3. Ratio of the $V_{TX-DIFFp-p}$ of the second and following bits after a transition divided by the $V_{TX-DIFFp-p}$ of the first bit after a transition.						
4. Transmitter DC differential mode low impedance.						
5. Required transmitter D+, as well as D- DC impedance during all states.						

This table provides the PCI Express 2.0 (5 GT/s) DC specifications for the differential output at all transmitters. The parameters are specified at the component pins.

Table 124. PCI Express 2.0 (5 GT/s) differential transmitter output DC specifications (X1V_{DD} = 1.35 V)¹

Parameter	Symbol	Min	Typical	Max	Units	Notes
Differential peak-to-peak output voltage	$V_{TX-DIFFp-p}$	800	1000	1200	mV	2
Low power differential peak-to-peak output voltage	$V_{TX-DIFFp-p_low}$	400	500	1200	mV	2
De-emphasized differential output voltage (ratio)	V_{TX-DE-} RATIO-3.5dB	3.0	3.5	4.0	dB	3
De-emphasized differential output voltage (ratio)	V_{TX-DE-} RATIO-6.0dB	5.5	6.0	6.5	dB	3
DC differential transmitter impedance	$Z_{TX-DIFF-DC}$	80	100	120	Ω	4
Transmitter DC Impedance	Z_{TX-DC}	40	50	60	Ω	5
Notes:						
1. For recommended operating conditions, see Table 3 .						
2. $V_{TX-DIFFp-p} = 2 \times V_{TX-D+} - V_{TX-D-} $						
3. Ratio of the $V_{TX-DIFFp-p}$ of the second and following bits after a transition divided by the $V_{TX-DIFFp-p}$ of the first bit after a transition.						
4. Transmitter DC differential mode low impedance.						
5. Required transmitter D+, as well as D- DC impedance during all states.						

3.27.4.3 PCI Express DC physical layer receiver specifications

This section discusses the PCI Express DC physical layer receiver specifications for 2.5 GT/s and 5 GT/s.

This table defines the DC specifications for the PCI Express 2.0 (2.5 GT/s) differential input at all receivers. The parameters are specified at the component pins.

Table 125. PCI Express 2.0 (2.5 GT/s) differential receiver input DC specifications (S1V_{DD} = 1.0 V)

Parameter	Symbol	Min	Typ	Max	Units	Notes
Differential input peak-to-peak voltage	V _{RX-DIFFp-p}	120	1000	1200	mV	1, 2
DC differential input impedance	Z _{RX-DIFF-DC}	80	100	120	Ω	3
DC input impedance	Z _{RX-DC}	40	50	60	Ω	1, 3, 4
Powered down DC input impedance	Z _{RX-HIGH-IMP-DC}	50	—	—	kΩ	5, 6
Electrical idle detect threshold	V _{RX-IDLE-DET-DIFFp-p}	65	—	175	mV	7, 8

Notes:

1. Measured at the package pins with a test load of 50Ω to GND on each pin.
2. $V_{RX-DIFFp-p} = 2 \times |V_{RX-D+} - V_{RX-D-}|$
3. Impedance during all LTSSM states. When transitioning from a fundamental reset to detect (the initial state of the LTSSM) there is a 5 ms transition time before receiver termination values must be met on all unconfigured lanes of a port.
4. Required receiver D+ as well as D- DC impedance (50 ± 20% tolerance).
5. The receiver DC common mode impedance that exists when no power is present or fundamental reset is asserted. This helps ensure that the receiver detect circuit does not falsely assume a receiver is powered on when it is not. This term must be measured at 300 mV above the receiver ground.
6. Required receiver D+ as well as D- DC impedance when the receiver terminations do not have power.
7. $V_{RX-IDLE-DET-DIFFp-p} = 2 \times |V_{RX-D+} - V_{RX-D-}|$
8. Measured at the package pins of the receiver.

This table defines the DC specifications for the PCI Express 2.0 (5 GT/s) differential input at all receivers. The parameters are specified at the component pins.

Table 126. PCI Express 2.0 (5 GT/s) differential receiver input DC specifications (S1V_{DD} = 1.0 V)

Parameter	Symbol	Min	Typ	Max	Units	Notes
Differential input peak-to-peak voltage	V _{RX-DIFFp-p}	120	1000	1200	mV	1, 2
DC differential input impedance	Z _{RX-DIFF-DC}	80	100	120	Ω	3
DC input impedance	Z _{RX-DC}	40	50	60	Ω	1, 3, 4
Powered down DC input impedance	Z _{RX-HIGH-IMP-DC}	50	—	—	kΩ	5, 6
Electrical idle detect threshold	V _{RX-IDLE-DET-DIFFp-p}	65	—	175	mV	7, 8

Notes:

1. Measured at the package pins with a test load of 50Ω to GND on each pin.
2. $V_{RX-DIFFp-p} = 2 \times |V_{RX-D+} - V_{RX-D-}|$
3. Impedance during all LTSSM states. When transitioning from a fundamental reset to detect (the initial state of the LTSSM) there is a 5 ms transition time before receiver termination values must be met on all unconfigured lanes of a port.
4. Required receiver D+ as well as D- DC impedance (50 ± 20% tolerance).

Table 126. PCI Express 2.0 (5 GT/s) differential receiver input DC specifications (S1V_{DD} = 1.0 V)

Parameter	Symbol	Min	Typ	Max	Units	Notes
5. The receiver DC common mode impedance that exists when no power is present or fundamental reset is asserted. This helps ensure that the receiver detect circuit does not falsely assume a receiver is powered on when it is not. This term must be measured at 300 mV above the receiver ground.						
6. Required receiver D+ as well as D- DC impedance when the receiver terminations do not have power.						
7. $V_{RX-IDLE-DET-DIFFp-p} = 2 \times V_{RX-D+} - V_{RX-D-} $						
8. Measured at the package pins of the receiver.						

3.27.4.4 PCI Express AC physical layer specifications

This section describes the AC specifications for the physical layer of PCI Express on this device.

3.27.4.4.1 PCI Express AC physical layer transmitter specifications

This section discusses the PCI Express AC physical layer transmitter specifications for 2.5 GT/s and 5 GT/s.

This table provides the PCI Express 2.0 (2.5 GT/s) AC specifications for the differential output at all transmitters. The parameters are specified at the component pins. The AC timing specifications do not include RefClk jitter.

Table 127. PCI Express 2.0 (2.5 GT/s) differential transmitter output AC specifications

Parameter	Symbol	Min	Typ	Max	Units	Notes
Unit interval	UI	399.88	400	400.12	ps	1
Minimum transmitter eye width	T _{TX-EYE}	0.75	—	—	UI	2, 3, 4
Maximum time between the jitter median and maximum deviation from the median	T _{TX-EYE-MEDIAN-to-MAX-JITTER}	—	—	0.125	UI	2, 4, 5
AC coupling capacitor	C _{TX}	75	—	200	nF	6, 7

Notes:

- Each UI is 400 ps ± 300 ppm. UI does not account for spread-spectrum clock dictated variations.
- Specified at the measurement point into a timing and voltage test load as shown in [Figure 80](#) and measured over any 250 consecutive transmitter UIs.
- The maximum transmitter jitter can be derived as $T_{TX-MAX-JITTER} = 1 - T_{TX-EYE} = 0.25 \text{ UI}$. Does not include spread-spectrum or RefCLK jitter. Includes device random jitter at 10⁻¹².
- A T_{TX-EYE} = 0.75 UI provides for a total sum of deterministic and random jitter budget of T_{TX-JITTER-MAX} = 0.25 UI for the transmitter collected over any 250 consecutive transmitter UIs. The T_{TX-EYE-MEDIAN-to-MAX-JITTER} median is less than half of the total transmitter jitter budget collected over any 250 consecutive transmitter UIs. It must be noted that the median is not the same as the mean. The jitter median describes the point in time where the number of jitter points on either side is approximately equal as opposed to the averaged time value.

Table 127. PCI Express 2.0 (2.5 GT/s) differential transmitter output AC specifications

Parameter	Symbol	Min	Typ	Max	Units	Notes
5. Jitter is defined as the measurement variation of the crossing points ($V_{TX-DIFFp-p} = 0$ V) in relation to a recovered transmitter UI. A recovered transmitter UI is calculated over 3,500 consecutive unit intervals of sample data. Jitter is measured using all edges of the 250 consecutive UI in the center of the 3,500 UI used for calculating the transmitter UI.						
6. The chip's SerDes transmitter does not have C_{TX} built-in. An external AC coupling capacitor of 100 nF is required.						
7. All transmitters must be AC coupled. The AC coupling is required either within the media or within the transmitting component itself.						

This table provides the PCI Express 2.0 (5 GT/s) AC specifications for the differential output at all transmitters. The parameters are specified at the component pins. The AC timing specifications do not include RefClk jitter.

Table 128. PCI Express 2.0 (5 GT/s) differential transmitter output AC specifications

Parameter	Symbol	Min	Typ	Max	Units	Notes
Unit Interval	UI	199.94	200.00	200.06	ps	1
Minimum transmitter eye width	T_{TX-EYE}	0.75	—	—	UI	2, 3
Transmitter RMS deterministic jitter > 1.5 MHz	$T_{TX-HF-DJ-DD}$	—	—	0.15	ps	—
Transmitter RMS deterministic jitter < 1.5 MHz	$T_{TX-LF-RMS}$	—	3.0	—	ps	4
AC coupling capacitor	C_{TX}	75	—	200	nF	5, 6

Notes:

- Each UI is 200 ps \pm 300 ppm. UI does not account for spread-spectrum clock dictated variations.
- Specified at the measurement point into a timing and voltage test load as shown in [Figure 80](#) and measured over any 250 consecutive transmitter UIs.
- The maximum transmitter jitter can be derived as: $T_{TX-MAX-JITTER} = 1 - T_{TX-EYE} = 0.25$ UI.
- Reference input clock RMS jitter (< 1.5 MHz) at pin < 1ps.
- The chip's SerDes transmitter does not have C_{TX} built-in. An external AC coupling capacitor of 100 nF is required.
- All transmitters must be AC coupled. The AC coupling is required either within the media or within the transmitting component itself.

3.27.4.4.2 PCI Express AC physical layer receiver specifications

This section discusses the PCI Express AC physical layer receiver specifications for 2.5 GT/s and 5 GT/s.

This table provides the AC specifications for the PCI Express 2.0 (2.5 GT/s) differential input at all receivers. The parameters are specified at the component pins. The AC timing specifications do not include RefClk jitter.

Table 129. PCI Express 2.0 (2.5 GT/s) differential receiver input AC specifications

Parameter	Symbol	Min	Typ	Max	Units	Notes
Unit Interval	UI	399.88	400.00	400.12	ps	1
Minimum receiver eye width	T_{RX-EYE}	0.4	—	—	UI	2, 3, 4
Maximum time between the jitter median and maximum deviation from the median	$T_{RX-EYE-MEDIAN-to-MAX-JITTER}$	—	—	0.3	UI	3, 4, 5, 6

Notes:

- Each UI is $400 \text{ ps} \pm 300 \text{ ppm}$. UI does not account for spread-spectrum clock dictated variations.
- The maximum interconnect media and transmitter jitter that can be tolerated by the receiver can be derived as $T_{RX-MAX-JITTER} = 1 - T_{RX-EYE} = 0.6 \text{ UI}$.
- Specified at the measurement point and measured over any 250 consecutive UIs. The test load in [Figure 80](#) must be used as the receiver device when taking measurements. If the clocks to the receiver and transmitter are not derived from the same reference clock, the transmitter UI recovered from 3500 consecutive UI must be used as a reference for the eye diagram.
- A $T_{RX-EYE} = 0.40 \text{ UI}$ provides for a total sum of 0.60 UI deterministic and random jitter budget for the transmitter and interconnect collected any 250 consecutive UIs. The $T_{RX-EYE-MEDIAN-to-MAX-JITTER}$ specification ensures a jitter distribution in which the median and the maximum deviation from the median is less than half of the total. UI jitter budget collected over any 250 consecutive transmitter UIs. It must be noted that the median is not the same as the mean. The jitter median describes the point in time where the number of jitter points on either side is approximately equal as opposed to the averaged time value. If the clocks to the receiver and transmitter are not derived from the same reference clock, the transmitter UI recovered from 3500 consecutive UI must be used as the reference for the eye diagram.
- It is recommended that the recovered transmitter UI is calculated using all edges in the 3500 consecutive UI interval with a fit algorithm using a minimization merit function. Least squares and median deviation fits have worked well with experimental and simulated data.
- Jitter is defined as the measurement variation of the crossing points ($V_{RX-DIFFp-p} = 0 \text{ V}$) in relation to a recovered transmitter UI. A recovered transmitter UI is calculated over 3,500 consecutive unit intervals of sample data. Jitter is measured using all edges of the 250 consecutive UI in the center of the 3,500 UI used for calculating the transmitter UI.

This table defines the AC specifications for the PCI Express 2.0 (5 GT/s) differential input at all receivers. The parameters are specified at the component pins. The AC timing specifications do not include RefClk jitter.

Table 130. PCI Express 2.0 (5 GT/s) differential receiver input AC specifications⁴

Parameter	Symbol	Min	Typ	Max	Units	Notes
Unit Interval	UI	199.40	200.00	200.06	ps	1
Max receiver inherent timing error	$T_{RX-TJ-CC}$	—	—	0.4	UI	2
Max receiver inherent deterministic timing error	$T_{RX-DJ-DD-CC}$	—	—	0.30	UI	3

Notes:

- Each UI is $200 \text{ ps} \pm 300 \text{ ppm}$. UI does not account for spread-spectrum clock dictated variations.
- The maximum inherent total timing error for common and separated RefClk receiver architecture.
- The maximum inherent deterministic timing error for common and separated RefClk receiver architecture.
- If spread spectrum clocking is desired, common clock must be used.

3.27.4.5 Test and measurement load

The AC timing and voltage parameters must be verified at the measurement point. The package pins of the device must be connected to the test/measurement load within 0.2 inches of that load, as shown in the following figure.

NOTE

The allowance of the measurement point to be within 0.2 inches of the package pins is meant to acknowledge that package/board routing may benefit from D+ and D- not being exactly matched in length at the package pin boundary. If the vendor does not explicitly state where the measurement point is located, the measurement point is assumed to be the D+ and D- package pins.

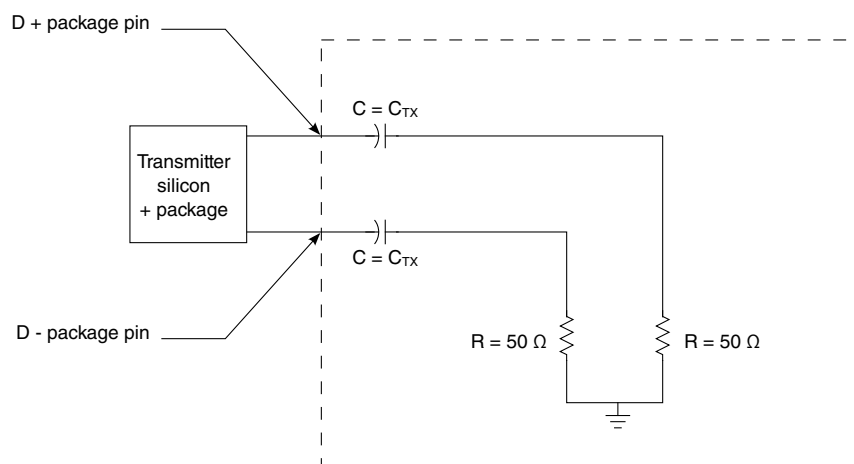

Figure 80. Test and measurement load

3.27.5 Serial ATA (SATA) interface

This section describes the DC and AC electrical specifications for the SATA interface.

3.27.5.1 SATA DC electrical characteristics

This section describes the DC electrical characteristics for SATA.

3.27.5.1.1 SATA DC transmitter output characteristics

This table provides the differential transmitter output DC characteristics for the SATA interface at Gen1i/1m or 1.5 Gbits/s transmission.

Electrical characteristics

Table 131. Gen1i/1m 1.5 G transmitter DC specifications ($X1V_{DD} = 1.35\text{ V}$)³

Parameter	Symbol	Min	Typ	Max	Units	Notes
Tx differential output voltage	$V_{\text{SATA_TXDIFF}}$	400	500	600	mV p-p	1
Tx differential pair impedance	$Z_{\text{SATA_TXDIFFIM}}$	85	100	115	Ω	2

Notes:

1. Terminated by 50 Ω load.
2. DC impedance.
3. For recommended operating conditions, see [Table 3](#).

This table provides the differential transmitter output DC characteristics for the SATA interface at Gen2i/2m or 3.0 Gbits/s transmission.

Table 132. Gen 2i/2m 3 G transmitter DC specifications ($X1V_{DD} = 1.35\text{ V}$)²

Parameter	Symbol	Min	Typ	Max	Units	Notes
Transmitter differential output voltage	$V_{\text{SATA_TXDIFF}}$	400	—	700	mV p-p	1
Transmitter differential pair impedance	$Z_{\text{SATA_TXDIFFIM}}$	85	100	115	Ω	—

Notes:

1. Terminated by 50 Ω load.
2. For recommended operating conditions, see [Table 3](#).

This table provides the differential transmitter output DC characteristics for the SATA interface at Gen 3i transmission.

Table 133. Gen 3i transmitter DC specifications ($X1V_{DD} = 1.35\text{ V}$)²

Parameter	Symbol	Min	Typ	Max	Units	Notes
Transmitter differential output voltage	$V_{\text{SATA_TXDIFF}}$	240	—	900	mV p-p	1
Transmitter differential pair impedance	$Z_{\text{SATA_TXDIFFIM}}$	85	100	115	Ω	—

Notes:

1. Terminated by 50 Ω load.
2. For recommended operating conditions, see [Table 3](#).

3.27.5.1.2 SATA DC receiver input characteristics

This table provides the Gen1i/1m or 1.5 Gbits/s differential receiver input DC characteristics for the SATA interface.

Table 134. Gen1i/1m 1.5 G receiver input DC specifications ($S1V_{DD} = 1.0 V$)³

Parameter	Symbol	Min	Typical	Max	Units	Notes
Differential input voltage	V_{SATA_RXDIFF}	240	500	600	mV p-p	1
Differential receiver input impedance	Z_{SATA_RXSEIM}	85	100	115	Ω	2
OOB signal detection threshold	V_{SATA_OOB}	50	120	240	mV p-p	—

Notes:

1. Voltage relative to common of either signal comprising a differential pair.
2. DC impedance.
3. For recommended operating conditions, see [Table 3](#).

This table provides the Gen2i/2m or 3 Gbits/s differential receiver input DC characteristics for the SATA interface.

Table 135. Gen2i/2m 3 G receiver input DC specifications ($S1V_{DD} = 1.0 V$)³

Parameter	Symbol	Min	Typical	Max	Units	Notes
Differential input voltage	V_{SATA_RXDIFF}	240	—	750	mV p-p	1
Differential receiver input impedance	Z_{SATA_RXSEIM}	85	100	115	Ω	2
OOB signal detection threshold	V_{SATA_OOB}	75	120	240	mV p-p	2

Notes:

1. Voltage relative to common of either signal comprising a differential pair.
2. DC impedance.
3. For recommended operating conditions, see [Table 3](#).

This table provides the Gen 3i differential receiver input DC characteristics for the SATA interface.

Table 136. Gen 3i receiver input DC specifications ($S1V_{DD} = 1.0 V$)³

Parameter	Symbol	Min	Typical	Max	Units	Notes
Differential input voltage	V_{SATA_RXDIFF}	240	—	1000	mV p-p	1
Differential receiver input impedance	Z_{SATA_RXSEIM}	85	100	115	Ω	2
OOB signal detection threshold	—	75	120	200	mV p-p	—

Notes:

1. Voltage relative to common of either signal comprising a differential pair.
2. DC impedance.
3. For recommended operating conditions, see [Table 3](#).

3.27.5.2 SATA AC timing specifications

This section describes the SATA AC timing specifications.

3.27.5.2.1 AC requirements for SATA REF_CLK

This table provides the AC requirements for the SATA reference clock. These requirements must be guaranteed by the customer's application design.

Table 137. SATA reference clock input requirements⁶

Parameter	Symbol	Min	Typ	Max	Unit	Notes
SD1_REF_CLK1_P/SD1_REF_CLK1_N frequency range	$t_{\text{CLK_REF}}$	—	100/125	—	MHz	1
SD1_REF_CLK1_P/SD1_REF_CLK1_N clock frequency tolerance	$t_{\text{CLK_TOL}}$	-350	—	+350	ppm	—
SD1_REF_CLK1_P/SD1_REF_CLK1_N reference clock duty cycle	$t_{\text{CLK_DUTY}}$	40	50	60	%	5
SD1_REF_CLK1_P/SD1_REF_CLK1_N cycle-to-cycle clock jitter (period jitter)	$t_{\text{CLK_CJ}}$	—	—	100	ps	2
SD1_REF_CLK1_P/SD1_REF_CLK1_N total reference clock jitter, phase jitter (peak-to-peak)	$t_{\text{CLK_PJ}}$	-50	—	+50	ps	2, 3, 4

Notes:

- Caution:** Only 100 and 125 MHz have been tested. In-between values do not work correctly with the rest of the system.
- At RefClk input.
- In a frequency band from 150 kHz to 15 MHz at BER of 10^{-12} .
- Total peak-to-peak deterministic jitter must be less than or equal to 50 ps.
- Measurement taken from differential waveform.
- For recommended operating conditions, see [Table 3](#).

3.27.5.3 AC transmitter output characteristics

This table provides the differential transmitter output AC characteristics for the SATA interface at Gen 1i/1m or 1.5 Gbits/s transmission. The AC timing specifications do not include RefClk jitter.

Table 138. Gen 1i/1m 1.5 G transmitter AC specifications²

Parameter	Symbol	Min	Typ	Max	Units	Notes
Channel speed	$t_{\text{CH_SPEED}}$	—	1.5	—	Gbps	—
Unit interval	T_{UI}	666.4333	666.6667	670.2333	ps	—
Total jitter data-data 5 UI	$U_{\text{SATA_TXTJ5UI}}$	—	—	0.355	UI p-p	1
Total jitter, data-data 250 UI	$U_{\text{SATA_TXTJ250UI}}$	—	—	0.47	UI p-p	1
Deterministic jitter, data-data 5 UI	$U_{\text{SATA_TXDJ5UI}}$	—	—	0.175	UI p-p	1
Deterministic jitter, data-data 250 UI	$U_{\text{SATA_TXDJ250UI}}$	—	—	0.22	UI p-p	1

Notes:

- Measured at transmitter output pins peak-to-peak phase variation; random data pattern.
- For recommended operating conditions, see [Table 3](#).

This table provides the differential transmitter output AC characteristics for the SATA interface at Gen 2i/2m or 3.0 Gbits/s transmission. The AC timing specifications do not include RefClk jitter.

Table 139. Gen 2i/2m 3 G transmitter AC specifications²

Parameter	Symbol	Min	Typ	Max	Units	Notes
Channel speed	t_{CH_SPEED}	—	3.0	—	Gbps	—
Unit Interval	T_{UI}	333.2167	333.3333	335.1167	ps	—
Total jitter $f_{C3dB} = f_{BAUD} \div 500$	$U_{SATA_TXTJfB/500}$	—	—	0.37	UI p-p	1
Total jitter $f_{C3dB} = f_{BAUD} \div 1667$	$U_{SATA_TXTJfB/1667}$	—	—	0.55	UI p-p	1
Deterministic jitter, $f_{C3dB} = f_{BAUD} \div 500$	$U_{SATA_TXDJfB/500}$	—	—	0.19	UI p-p	1
Deterministic jitter, $f_{C3dB} = f_{BAUD} \div 1667$	$U_{SATA_TXDJfB/1667}$	—	—	0.35	UI p-p	1

Notes:

1. Measured at transmitter output pins peak-to-peak phase variation; random data pattern.
2. For recommended operating conditions, see [Table 3](#).

This table provides the differential transmitter output AC characteristics for the SATA interface at Gen 3i transmission. The AC timing specifications do not include RefClk jitter.

Table 140. Gen 3i transmitter AC specifications ($S1V_{DD} = 1.0 V$)

Parameter	Symbol	Min	Typ	Max	Units
Speed	—	—	6.0	—	Gb/s
Total jitter before and after compliance interconnect channel	J_T	—	—	0.52	UI p-p
Random jitter before compliance interconnect channel	J_R	—	—	0.18	UI p-p
Unit interval	UI	166.6083	166.6667	167.5583	ps

3.27.5.4 AC differential receiver input characteristics

This table provides the Gen1i/1m or 1.5 Gbits/s differential receiver input AC characteristics for the SATA interface. The AC timing specifications do not include RefClk jitter.

Table 141. Gen 1i/1m 1.5 G receiver AC specifications²

Parameter	Symbol	Min	Typical	Max	Units	Notes
Unit Interval	T_{UI}	666.4333	666.6667	670.2333	ps	—
Total jitter data-data 5 UI	$U_{SATA_RXTJ5UI}$	—	—	0.43	UI p-p	1
Total jitter, data-data 250 UI	$U_{SATA_RXTJ250UI}$	—	—	0.60	UI p-p	1

Table continues on the next page...

Table 141. Gen 1i/1m 1.5 G receiver AC specifications² (continued)

Parameter	Symbol	Min	Typical	Max	Units	Notes
Deterministic jitter, data-data 5 UI	$U_{SATA_RXDJ5UI}$	—	—	0.25	UI p-p	1
Deterministic jitter, data-data 250 UI	$U_{SATA_RXDJ250UI}$	—	—	0.35	UI p-p	1
Notes:						
1. Measured at the receiver.						
2. For recommended operating conditions, see Table 3 .						

This table provides the differential receiver input AC characteristics for the SATA interface at Gen2i/2m or 3.0 Gbits/s transmission. The AC timing specifications do not include RefClk jitter.

Table 142. Gen 2i/2m 3 G receiver AC specifications²

Parameter	Symbol	Min	Typical	Max	Units	Notes
Unit Interval	T_{UI}	333.2167	333.3333	335.1167	ps	—
Total jitter $f_{C3dB} = f_{BAUD} \div 500$	$U_{SATA_RXTJfB/500}$	—	—	0.60	UI p-p	1
Total jitter $f_{C3dB} = f_{BAUD} \div 1667$	$U_{SATA_RXTJfB/1667}$	—	—	0.65	UI p-p	1
Deterministic jitter, $f_{C3dB} = f_{BAUD} \div 500$	$U_{SATA_RXDJfB/500}$	—	—	0.42	UI p-p	1
Deterministic jitter, $f_{C3dB} = f_{BAUD} \div 1667$	$U_{SATA_RXDJfB/1667}$	—	—	0.35	UI p-p	1
Notes:						
1. Measured at the receiver.						
2. For recommended operating conditions, see Table 3 .						

This table provides the differential receiver input AC characteristics for the SATA interface at Gen 3i transmission. The AC timing specifications do not include RefClk jitter.

Table 143. Gen 3i receiver AC specifications²

Parameter	Symbol	Min	Typical	Max	Units	Notes
Total jitter after compliance interconnect channel	J_T	—	—	0.60	UI p-p	1
Random jitter before compliance interconnect channel	J_R	—	—	0.18	UI p-p	1
Unit interval: 6.0 Gb/s	UI	166.6083	166.6667	167.5583	ps	—
Notes:						
1. Measured at the receiver.						
2. The AC specifications do not include RefClk jitter.						

4 Hardware design considerations

4.1 Power supply design

4.1.1 Core and platform supply voltage filtering

The V_{DD} , V_{DDC} supply is normally derived from a linear regulator or switching power supply that can regulate its output voltage very accurately despite changes in current demand from the chip within the regulator's relatively low bandwidth. Several bulk decoupling capacitors must be distributed around the PCB to supply transient current demand above the bandwidth of the voltage regulator.

These bulk capacitors should have a low equivalent series resistance (ESR) rating to ensure a quick response time. They should also be connected to the power and ground planes through two vias to minimize inductance. Customers should work directly with their power regulator vendor for best values and types of bulk capacitors.

As a guideline for customers and their power regulator vendors, NXP recommends that these bulk capacitors be chosen to maintain the positive transient power surges to less than +50 mV (negative transient undershoot should comply with specification of -30 mV) for current steps of up to 2A with a slew rate of 1.5A/ μ s.

These bulk decoupling capacitors will ideally supply a stable voltage for current transients into the megahertz range. Above that, see [Decoupling recommendations](#) for further decoupling recommendations.

4.1.2 PLL power supply filtering

Each of the PLLs is provided with power through independent power supply pins (AV_{DD_PLAT} , AV_{DD_CGA1} , AV_{DD_D1} and $AV_{DD_SD1_PLLn}$). AV_{DD_PLAT} , AV_{DD_CGA1} , and AV_{DD_D1} voltages must be derived directly from a 1.8 V voltage source through a low frequency filter scheme. $AV_{DD_SD1_PLLn}$ voltages must be derived directly from the $X1V_{DD}$ source through a low frequency filter scheme. The recommended solution for PLL filtering is to provide independent filter circuits per PLL power supply, as illustrated in [Figure 81](#), one for each of the AV_{DD} pins. By providing independent filters to each PLL, the opportunity to cause noise injection from one PLL to the other is reduced. This circuit is intended to filter noise in the PLL's resonant frequency range from a 500 kHz to 10 MHz range.

Each circuit should be placed as close as possible to the specific AV_{DD} pin being supplied to minimize noise coupled from nearby circuits. It should be possible to route directly from the capacitors to the AV_{DD} pin, which is on the periphery of the footprint, without the inductance of vias.

This figure shows the PLL power supply filter circuit.

Where:

- $R = 5 \Omega \pm 5\%$
- $C1 = 10 \mu\text{F} \pm 10\%$, 0603, X5R, with $ESL \leq 0.5 \text{ nH}$
- $C2 = 1.0 \mu\text{F} \pm 10\%$, 0402, X5R, with $ESL \leq 0.5 \text{ nH}$

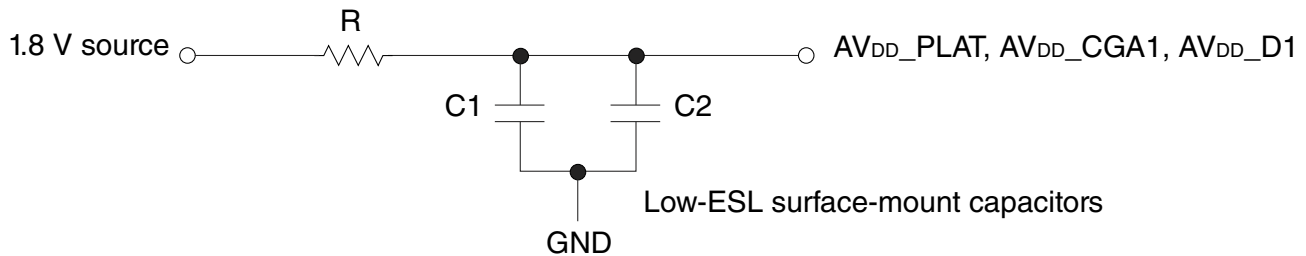

Figure 81. PLL power supply filter circuit

Note the following:

- A higher capacitance value for C2 may be used to improve the filter as long as the other C2 parameters do not change (0402 body, X5R, $ESL \leq 0.5 \text{ nH}$).
- Voltage for AV_{DD} is defined at the input of the PLL supply filter and not the pin of AV_{DD} .

The $AV_{DD_SD1_PLLn}$ signals provide power for the analog portions of the SerDes PLL. To ensure stability of the internal clock, the power supplied to the PLL is filtered using a circuit similar to the one shown in following [Figure 82](#). For maximum effectiveness, the filter circuit is placed as closely as possible to the $AV_{DD_SD1_PLLn}$ balls to ensure it filters out as much noise as possible. The ground connection should be near the $AV_{DD_SD1_PLLn}$ balls. The $0.003\text{-}\mu\text{F}$ capacitors should be closest to the balls, followed by a $4.7\text{-}\mu\text{F}$ and $47\text{-}\mu\text{F}$ capacitor, and finally the 0.33Ω resistor to the board supply plane. The capacitors are connected from $AV_{DD_SD1_PLLn}$ to the ground plane. Use ceramic chip capacitors with the highest possible self-resonant frequency. All traces should be kept short, wide, and direct.

This figure shows the PLL power supply filter circuit for the SerDes.

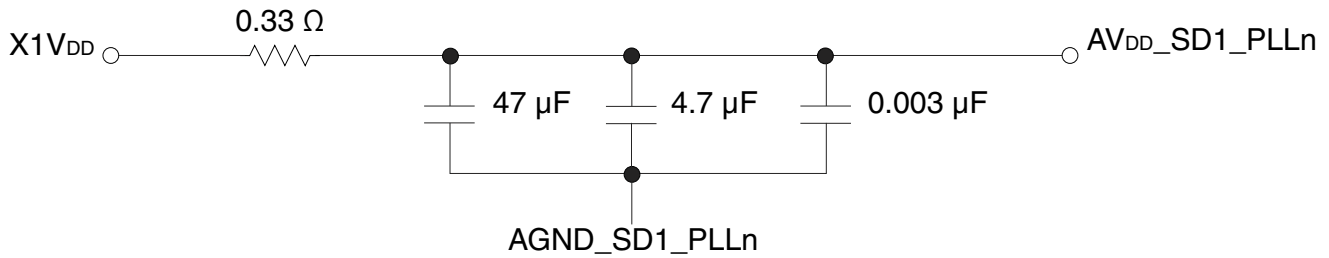

Figure 82. SerDes PLL power supply filter circuit

Note the following:

- $AV_{DD_SD1_PLLn}$ should be a filtered version of $X1V_{DD}$.
- Signals on the SerDes interface are fed from the $X1V_{DD}$ power plane.
- Voltage for $AV_{DD_SD1_PLLn}$ is defined at the PLL supply filter and not the pin of $AV_{DD_SD1_PLLn}$.
- The 47- μ F 0805 XR5 or XR7, 4.7- μ F 0603, and 0.003- μ F 0402 capacitors are recommended. The size and material type are important. A 0.33- $\Omega \pm 1\%$ resistor is recommended.
- There needs to be dedicated analog ground, $AGND_SD1_PLLn$ for each $AV_{DD_SD1_PLLn}$ pin up to the physical locale of the filters themselves.

4.1.3 $S1V_{DD}$ power supply filtering

$S1V_{DD}$ may be supplied by a linear regulator or sourced by a filtered V_{DD} . Systems may design in both options to allow flexibility to address system noise dependencies.

NOTE

For initial system bring-up, the linear regulator option is highly recommended.

The following figure illustrates an example solution for $S1V_{DD}$ filtering, where $S1V_{DD}$ is sourced from a linear regulator. The component values in this example filter are system dependent and are still under characterization. Component values may need adjustment based on the system or environment noise.

Where:

- $C1 = 0.003 \mu\text{F} \pm 10\%$, X5R, with $ESL \leq 0.5 \text{ nH}$
- $C2$ and $C3 = 2.2 \mu\text{F} \pm 10\%$, X5R, with $ESL \leq 0.5 \text{ nH}$
- $F1$ and $F2 = 120 \Omega$ at 100 MHz 2A 25% 0603 Ferrite (for example, Murata BLM18PG121SH1)
- Bulk and decoupling capacitors are added, as needed, per power supply design.

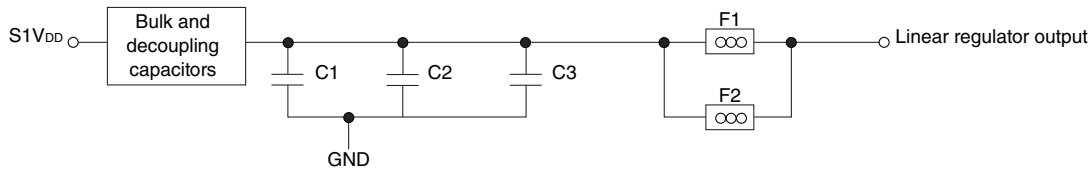

Figure 83. S1V_{DD} power supply filter circuit

Note the following:

- For maximum S1V_{DD} power-up ramp rate, see [Table 11](#).
- There needs to be enough output capacitance or a soft start feature to ensure the ramp rate requirement is met.
- The ferrite beads should be placed in parallel to reduce voltage droop.
- Besides a linear regulator, a low-noise, dedicated switching regulator can also be used. The goal is 10 mVp-p, 50 kHz - 500 MHz.

4.1.4 X1V_{DD} power supply filtering

X1V_{DD} must be supplied by a linear regulator or sourced by a filtered G1V_{DD}. Systems may design in both options to allow flexibility to address system noise dependencies.

NOTE

For initial system bring-up, the linear regulator option is highly recommended.

The following figure is an example solution for X1V_{DD} filtering, where X1V_{DD} is sourced from a linear regulator. The component values in this example filter are system dependent and are still under characterization. Component values may need adjustment based on the system or environment noise.

Where:

- C1 = 0.003 μ F \pm 10%, X5R, with ESL \leq 0.5 nH
- C2 and C3 = 2.2 μ F \pm 10%, X5R, with ESL \leq 0.5 nH
- F1 and F2 = 120 Ω at 100 MHz 2A 25% 0603 Ferrite (for example, Murata BLM18PG121SH1)
- Bulk and decoupling capacitors are added, as needed, per power supply design.

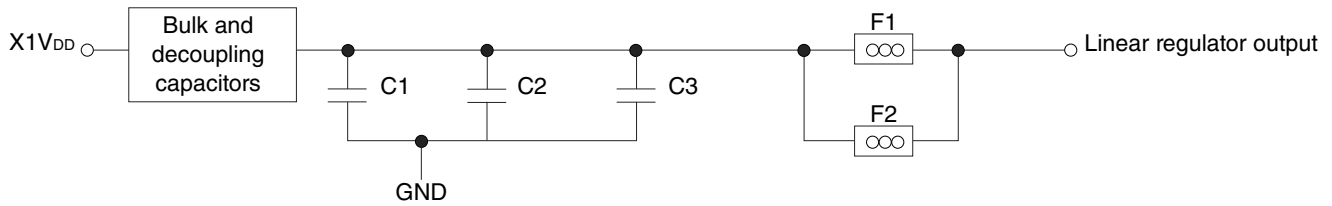

Figure 84. X1V_{DD} power supply filter circuit

Note the following:

- For maximum X1V_{DD} power-up ramp rate, see [Table 11](#).
- There needs to be enough output capacitance or a soft-start feature to ensure the ramp rate requirement is met.
- The ferrite beads should be placed in parallel to reduce voltage droop.
- Besides a linear regulator, a low-noise, dedicated switching regulator can be used. 10 mVp-p, 50 kHz - 500 MHz is the noise goal.

4.1.5 USB_HV_{DD} power supply filtering

USB_HV_{DD} must be sourced by a filtered 3.3 V voltage source using a star connection.

The following figure illustrates an example solution for USB_HV_{DD} filtering, where USB_HV_{DD} is sourced from a 3.3 V voltage source. The component values in this example filter are system dependent and are still under characterization. Component values may need adjustment based on the system or environment noise.

Where:

- C1 = 0.003 $\mu\text{F} \pm 10\%$, X5R, with ESL ≤ 0.5 nH
- C2 and C3 = 2.2 $\mu\text{F} \pm 10\%$, X5R, with ESL ≤ 0.5 nH
- F1 = 120 Ω at 100 MHz 2A 25% 0603 Ferrite (for example, Murata BLM18PG121SH1)
- Bulk and decoupling capacitors are added, as needed, per power supply design.

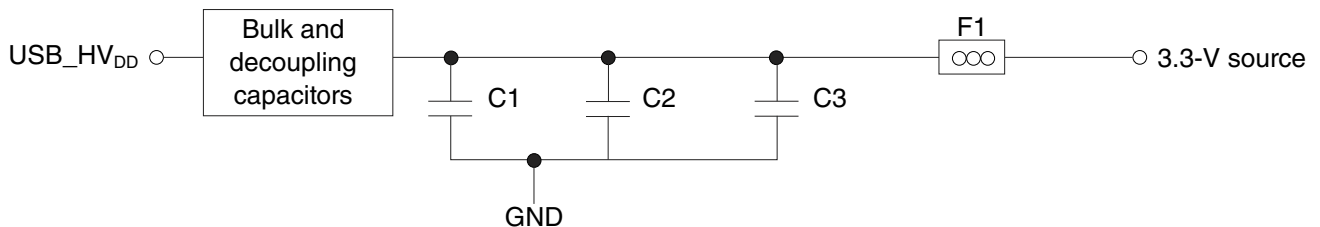

Figure 85. USB_HV_{DD} power supply filter circuit

4.1.6 USB_SnV_{DD} power supply filtering (SDV_{DD}, SPV_{DD}, SXV_{DD})

USB_SnV_{DD} must be sourced by a filtered V_{DD} using a star connection.

The following figure illustrates an example solution for USB_SnV_{DD} filtering, where USB_SnV_{DD} is sourced from V_{DD}. The component values in this example filter are system dependent and are still under characterization. Component values may need adjustment based on the system or environment noise.

Where:

- C1 = 2.2 μ F \pm 20%, X5R, with Low ESL (for example, Panasonic ECJ0EB0J225M)
- F1 = 120 Ω at 100-MHz 2A 25% Ferrite (for example, Murata BLM18PG121SH1)
- Bulk and decoupling capacitors are added, as needed, per power supply design.

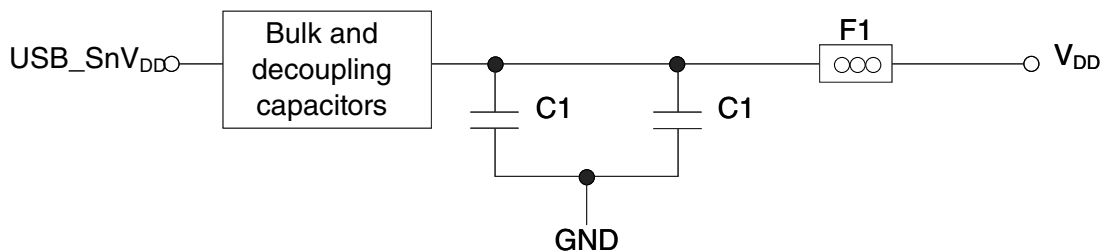

Figure 86. USB_SnV_{DD} power supply filter circuit

4.2 Decoupling recommendations

Because of large address and data buses and high operating frequencies, the device can generate transient power surges and high frequency noise in its power supply, especially while driving large capacitive loads. This noise must be prevented from reaching other components in the chip system, and the chip itself requires a clean, tightly regulated source of power. Therefore, it is recommended that the system designer place at least one decoupling capacitor at each V_{DD}, V_{DDC}, TA_BB_V_{DD}, O1V_{DD}, OV_{DD}, BV_{DD}, D1V_{DD}, DV_{DD}, EV_{DD}, L1V_{DD}, LV_{DD}, and G1V_{DD} pin of the device. These decoupling capacitors should receive their power from separate V_{DD}, V_{DDC}, TA_BB_V_{DD}, O1V_{DD}, OV_{DD}, BV_{DD}, D1V_{DD}, DV_{DD}, EV_{DD}, L1V_{DD}, LV_{DD}, G1V_{DD}, and GND power planes in the PCB, utilizing short traces to minimize inductance. Capacitors may be placed directly under the device using a standard escape pattern. Others may surround the part.

These capacitors should have a value of 0.1 μ F. Only ceramic surface mount technology (SMT) capacitors should be used to minimize lead inductance, preferably 0402 or 0603 sizes.

As presented in [Core and platform supply voltage filtering](#), it is recommended that there be several bulk storage capacitors distributed around the PCB, feeding the V_{DD} , V_{DDC} and other planes (for example, V_{DD} , DV_{DD} , EV_{DD} , LV_{DD} , and $G1V_{DD}$), to enable quick recharging of the smaller chip capacitors.

4.3 SerDes block power supply decoupling recommendations

The SerDes block requires a clean, tightly regulated source of power ($S1V_{DD}$ and $X1V_{DD}$) to ensure low jitter on transmit and reliable recovery of data in the receiver. An appropriate decoupling scheme is outlined below:

1. The board should have at least 1 x 0.1-uF SMT ceramic chip capacitor placed as close as possible to each supply ball of the device. Where the board has blind vias, these capacitors should be placed directly below the chip supply and ground connections. Where the board does not have blind vias, these capacitors should be placed in a ring around the device as close to the supply and ground connections as possible.
2. Between the device and any SerDes voltage regulator, there should be a lower bulk capacitor. For example, a 10-uF, low ESR SMT tantalum or ceramic capacitor. There should also be a higher bulk capacitor. For example, a 100uF - 300-uF low ESR SMT tantalum or ceramic capacitor.

NOTE

Only SMT capacitors should be used to minimize inductance. Connections from all capacitors to power and ground should be done with multiple vias to further reduce inductance.

4.4 Connection recommendations

The following is a list of connection recommendations:

- To ensure reliable operation, it is highly recommended to connect unused inputs to an appropriate signal level. Unless otherwise noted in this document, all unused active low inputs should be tied to V_{DD} , V_{DDC} , $TA_BB_V_{DD}$, $O1V_{DD}$, and OV_{DD} , BV_{DD} , $D1V_{DD}$, DV_{DD} , EV_{DD} , $L1V_{DD}$, LV_{DD} , and $G1V_{DD}$, as required. All unused active high inputs should be connected to GND. All NC (no-connect) signals must remain unconnected. Power and ground connections must be made to all external V_{DD} , V_{DDC} , $TA_BB_V_{DD}$, $O1V_{DD}$, OV_{DD} , BV_{DD} , $D1V_{DD}$, DV_{DD} , EV_{DD} , $L1V_{DD}$, LV_{DD} , $G1V_{DD}$, and GND pins of the device.
- The TEST_SEL_B pin must be pulled to OV_{DD} through a 100-ohm to 1k-ohm resistor.

4.4.1 JTAG configuration signals

Correct operation of the JTAG interface requires configuration of a group of system control pins, as demonstrated in [Figure 88](#). Take care to ensure that these pins are maintained at a valid deasserted state under normal operating conditions as most have asynchronous behavior and spurious assertion will give unpredictable results.

The JTAG port of these processors allows a remote computer system (typically, a PC with dedicated hardware and debugging software) to access and control the internal operations of the processor. The ARM Cortex 10-pin header connects primarily through the JTAG port of the processor, with some additional status monitoring signals.

The Cortex Debug Connector has a standard header, as shown in [Figure 87](#). The connector typically has pin 7 removed as a connector key.

The ARM Cortex 10-pin header adds many benefits, such as breakpoints, watchpoints, register and memory examination/modification, and other standard debugger features. An inexpensive option can be to leave the ARM Cortex 10-pin header unpopulated until needed.

4.4.1.1 Termination of unused signals

If the JTAG interface and ARM Cortex 10-pin header are not used, no pull-up/pull-down is required for TDI, TMS, or TDO.

This figure shows the ARM Cortex 10-pin header physical pinout.

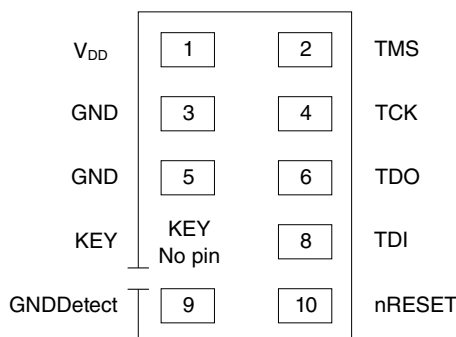

Figure 87. ARM Cortex 10-pin header physical pinout

This figure shows the JTAG interface connection.

4.4.2.1 SerDes interface entirely unused

If the high-speed SerDes interface is not used at all, the unused pin should be terminated as described in this section.

Note that $S1V_{DD}$, $X1V_{DD}$, $AVDD_{SD1_PLL1}$, and $AVDD_{SD1_PLL2}$ must remain powered.

$AVDD_{SD1_PLL1}$ must be connected to $X1V_{DD}$ through a $0\text{-}\Omega$ resistor (instead of through a filter circuit, as shown in [Figure 82](#)).

The following pins must be left unconnected:

- $SD1_TX[3:0]_P$
- $SD1_TX[3:0]_N$
- $SD1_IMP_CAL_RX$
- $SD1_IMP_CAL_TX$

The following pins must be connected to $S1GND$:

- $SD1_REF_CLK1_P$, $SD1_REF_CLK2_P$
- $SD1_REF_CLK1_N$, $SD1_REF_CLK2_N$

It is recommended for the following pins to be connected to $S1GND$:

- $SD1_RX[3:0]_P$
- $SD1_RX[3:0]_N$

It is possible to disable the SerDes module by disabling all PLLs associated with it. Use the following method to disable the SerDes module:

- $SRDS_PLL_PD_S1 = 2'b11$ (Both PLLs are configured as powered down; all data lanes selected by the protocols defined in $SRDS_PRTCL_S1$ associated to the PLLs are powered down, as well.)
- $SRDS_PLL_REF_CLK_SEL_S1 = 2'b00$
- $SRDS_PRTCL_S1 = 2$ (No other values are permitted when both PLLs are powered down.)

4.4.2.2 SerDes interface partly unused

If only part of the high-speed SerDes interface pins are used, the remaining high-speed serial I/O pins should be terminated as described in this section.

Note that both $S1V_{DD}$ and $X1V_{DD}$ must remain powered.

If any of the PLLs are unused, the corresponding AVDD_SD1_PLL1 and AVDD_SD1_PLL2 must be connected to X1V_{DD} through a 0-Ω resistor (instead of through a filter circuit, as shown in [Figure 82](#)).

The following unused pins must be left unconnected:

- SD1_TX0_P
- SD1_TX0_N

The following unused pins must be connected to S1GND:

- SD1_REF_CLK_n_P, SD1_REF_CLK_n_N (If the entire SerDes is unused.)

It is recommended for the following unused pins to be connected to S1GND:

- SD1_RX0_P
- SD1_RX0_N

In the RCW configuration field SRDS_PLL_PD_S1, the respective bits for each unused PLL must be set to power it down. A module is disabled when both its PLLs are turned off.

Unused lanes must be powered down through the SRDS_x Lane m General Control 0 (SRDS_xLNmGCR0) register as follows:

- SRDS_xLNmGCR0[RRST] = 0
- SRDS_xLNmGCR0[TRST] = 0
- SRDS_xLNmGCR0[RX_PD] = 1
- SRDS_xLNmGCR0[TX_PD] = 1

Note that in the case where the SerDes pins are connected to slots, it is acceptable to have these pins unterminated when unused.

4.4.3 USB1 PHY connections

This section describes the hardware connections required for the USB PHY.

This figure shows the VBUS interface for the chip.

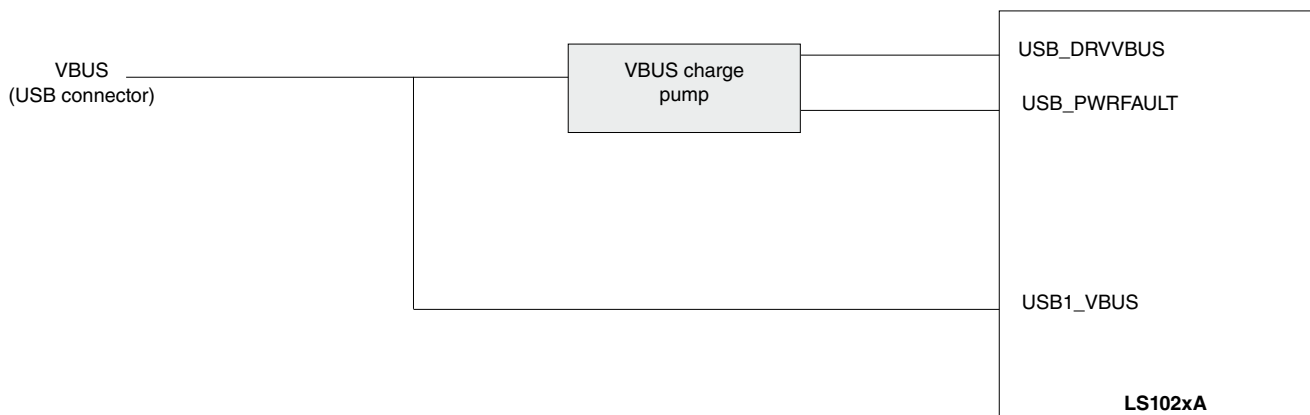

Figure 89. USB1 PHY VBUS interface

4.5 Thermal

This table provides the thermal characteristics for the chip. Note that these numbers are based on design estimates and are preliminary.

Table 144. Package thermal characteristics⁵

Rating	Board	Symbol	Value	Unit	Notes
Junction to ambient, natural convection	Single-layer board (1s)	$R_{\theta JA}$	47	°C/W	1, 2
Junction to ambient, natural convection	Four-layer board (2s2p)	$R_{\theta JA}$	43	°C/W	1, 3
Junction to ambient (at 200 ft./min.)	Single-layer board (1s)	$R_{\theta JMA}$	45	°C/W	1, 2
Junction to ambient (at 200 ft./min.)	Four-layer board (2s2p)	$R_{\theta JMA}$	38	°C/W	1, 2
Junction to board	—	$R_{\theta JB}$	33	°C/W	3
Junction to case top	—	$R_{\theta JCtop}$	<0.1	°C/W	4

Notes:

- Junction temperature is a function of die size, on-chip power dissipation, package thermal resistance, mounting site (board) temperature, ambient temperature, air flow, power dissipation of other components on the board, and board thermal resistance.
- Junction-to-ambient thermal resistance determined per JEDEC JESD51-3 and JESD51-6 with the board (JESD51-9) horizontal.
- Junction-to-board thermal resistance determined per JEDEC JESD51-8. Thermal test board meets JEDEC specification for the specified package.
- Junction-to-case top at the top of the package determined using MIL-STD 883 Method 1012.1. The cold plate temperature is used for the case temperature. Reported value includes the thermal resistance of the interface layer.
- For additional details, see [Thermal management information](#).

4.6 Recommended thermal model

Information about Flotherm models of the package or thermal data not available in this document can be obtained from your local NXP sales office.

4.7 Thermal management information

This section describes the thermal management information for the flip-chip, plastic-ball, grid array (FC-PBGA) package for air-cooled applications. Proper thermal control design is primarily dependent on the system-level design — the heat sink, airflow, and thermal interface material.

The recommended attachment method to the heat sink is illustrated in the following figure. The heat sink should be attached to the printed-circuit board with the spring force centered over the die. This spring force should not exceed 10 pounds force (45 Newton).

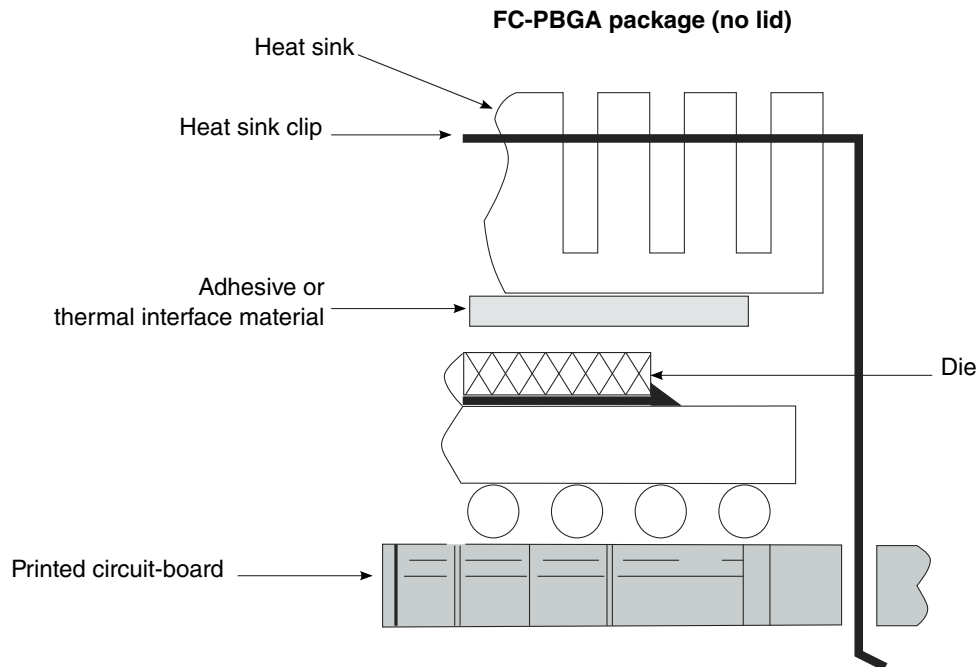

Figure 90. Package exploded, cross-sectional view-FC-PBGA (no lid)

The system board designer can choose between several types of heat sinks to place on the device. There are several commercially available thermal interfaces to choose from in the industry. Ultimately, the final selection of an appropriate heat sink depends on many factors, such as thermal performance at a given air velocity, spatial volume, mass, attachment method, assembly, and cost.

For additional information regarding thermal management of lid-less flip-chip packages, see application note AN4871, "Assembly Handling and Thermal Solutions for Lidless Flip Chip Ball Grid Array Packages".

4.7.1 Internal package conduction resistance

For the package, the intrinsic internal conduction thermal resistance paths are as follows:

- The die junction-to-case thermal resistance
- The die junction-to-board thermal resistance

This figure shows the primary heat transfer path for a package with an attached heat sink mounted to a printed-circuit board.

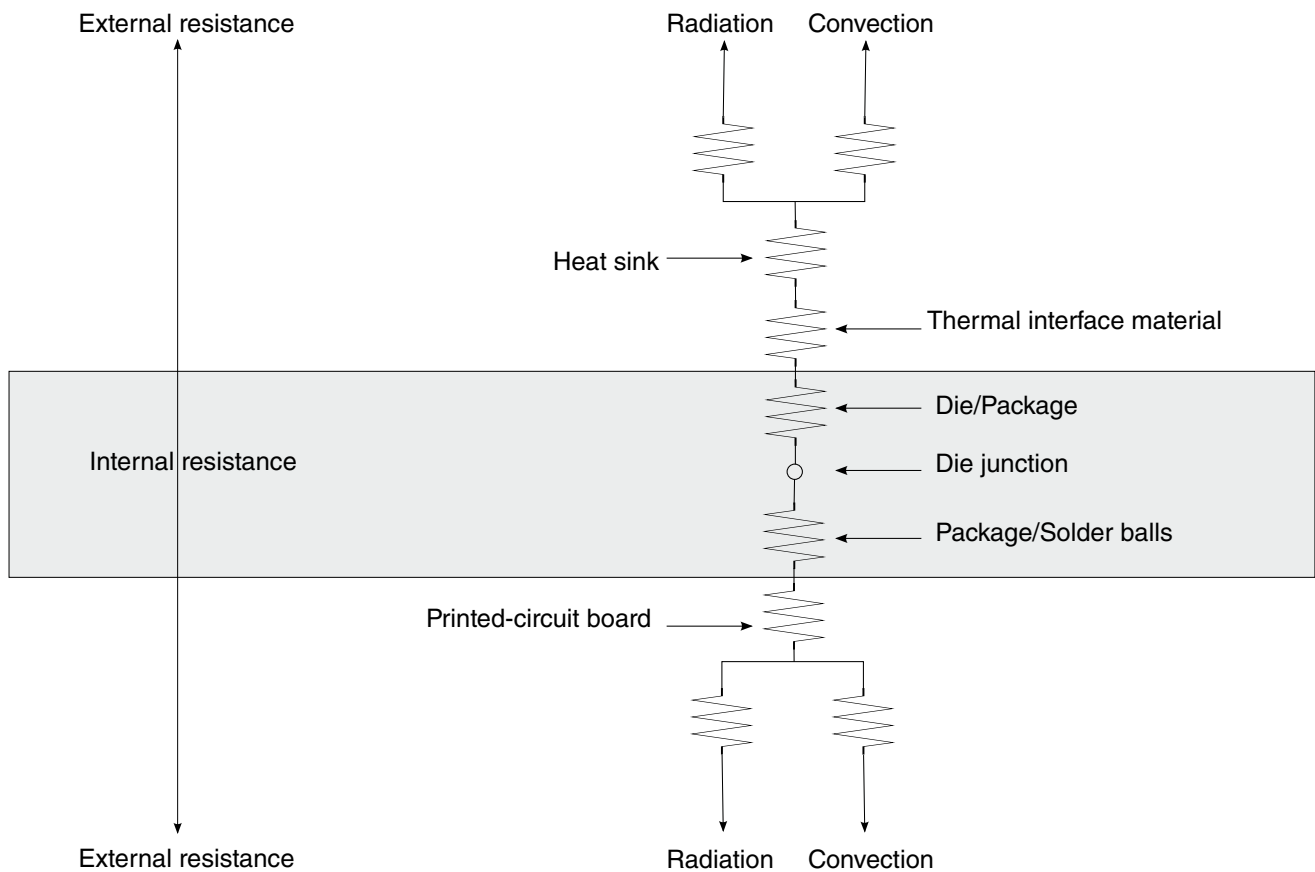

(Note the internal versus external package resistance)

Figure 91. Package with heat sink mounted to a printed-circuit board

The heat sink removes most of the heat from the device. Heat generated on the active side of the chip is conducted through the silicon and through the heat sink attach material (or thermal interface material), and finally to the heat sink. The junction-to-case thermal resistance is low enough that the heat sink attach material and heat sink thermal resistance are the dominant terms.

4.7.2 Thermal interface materials

A thermal interface material is required at the package-to-heat sink interface to minimize the thermal contact resistance. The performance of thermal interface materials improves with increasing contact pressure; this performance characteristic chart is generally provided by the thermal interface vendor. The recommended method of mounting heat sinks on the package is by means of a spring clip attachment to the printed-circuit board (see [Figure 90](#)).

The system board designer can choose among several types of commercially available thermal interface materials.

5 Package information

5.1 Mechanical dimensions of the FC-PBGA

This figure shows the mechanical dimensions and bottom surface nomenclature of the chip.

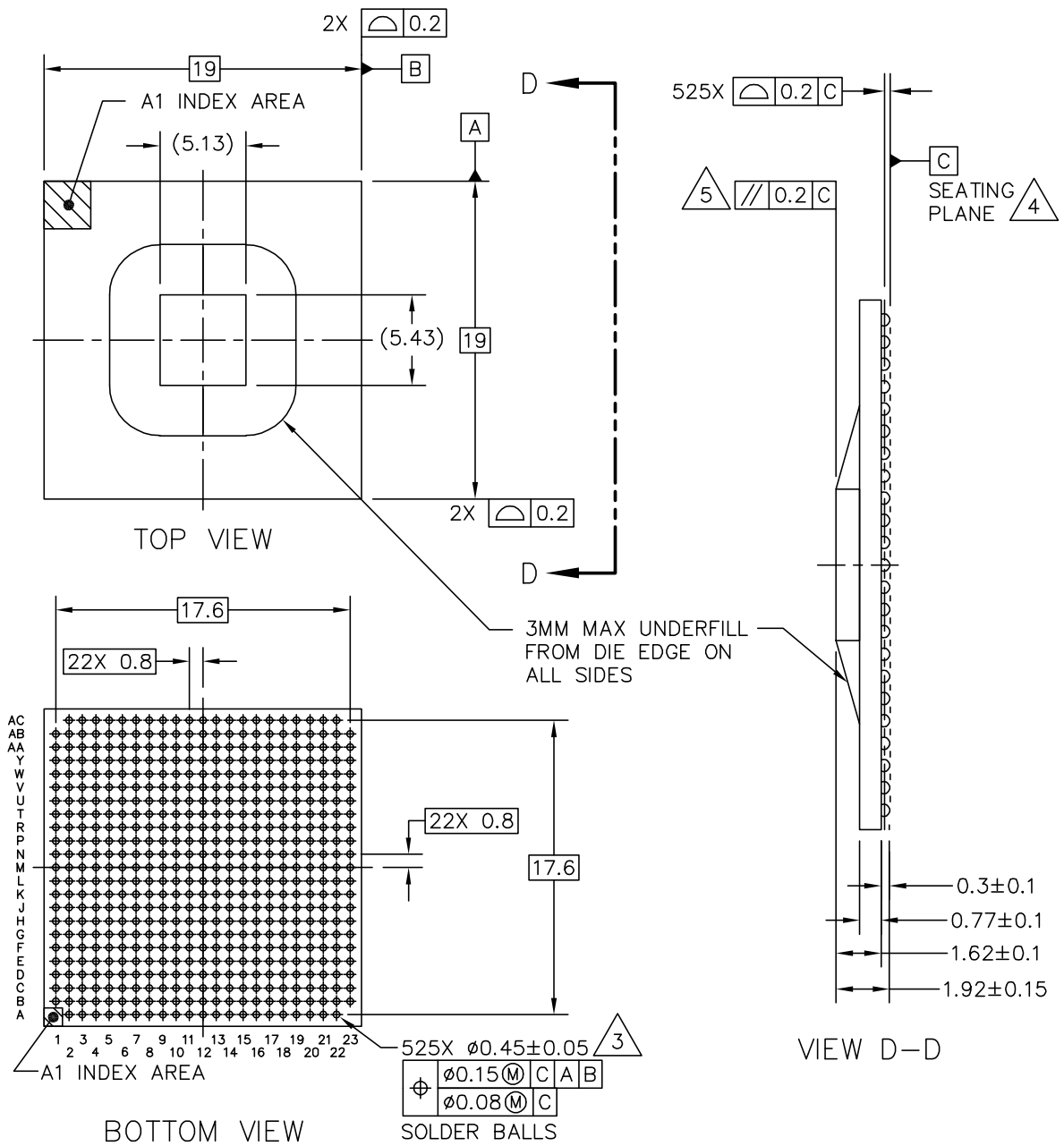

© FREESCALE SEMICONDUCTOR, INC. ALL RIGHTS RESERVED.	MECHANICAL OUTLINE	PRINT VERSION NOT TO SCALE
TITLE: FCPBGA, NO LID, 19 X 19 X 1.92 PKG, 0.8 MM PITCH, 525 I/O	DOCUMENT NO: 98ASA00579D	REV: A
	STANDARD: NON-JEDEC	
18 APR 2013		

Figure 92. Mechanical dimensions of the FC-PBGA

Notes:

1. All dimensions in millimeters.
2. Dimensioning and tolerancing per ASME Y14.5M - 1994.
3. Maximum solder ball diameter measured parallel to datum C.
4. Datum C, the seating plane, is determined by the spherical crowns of the solder balls.
5. Parallelism measurement shall exclude any effect of mark on top surface of package.

6 Security fuse processor

This chip implements the QorIQ platform's Trust Architecture, supporting capabilities such as secure boot. Use of the Trust Architecture features is dependent on programming fuses in the Security Fuse Processor (SFP). The details of the Trust Architecture and SFP can be found in the chip reference manual.

To program SFP fuses, the user is required to supply 1.8 V to the TA_PROG_SFP pin per [Power sequencing](#). TA_PROG_SFP should only be powered for the duration of the fuse programming cycle, with a per device limit of two fuse programming cycles. All other times, TA_PROG_SFP should be connected to GND. The sequencing requirements for raising and lowering TA_PROG_SFP are shown in [Power sequencing](#). To ensure device reliability, fuse programming must be performed within the recommended fuse programming temperature range per [Table 3](#).

NOTE

Users not implementing the QorIQ platform's Trust Architecture features should connect TA_PROG_SFP to GND.

7 Ordering information

7.1 Part numbering nomenclature

This table provides the NXP QorIQ platform part numbering nomenclature.

Table 145. Part numbering nomenclature

<i>p</i>	<i>ls</i>	<i>n</i>	<i>nn</i>	<i>n</i>	<i>x</i>	<i>t</i>	<i>e</i>	<i>n</i>	<i>c</i>	<i>d</i>	<i>r</i>
Qual Status	Generation	Performance level	Number of virtual cores	Unique ID	Core type	Temperature range	Encryption	Package type	CPU speed	DDR data rate	Die revision
P="Prot otype" S="Spec ial" Blank="" Qual"	LS	1	02	0	A = ARM	S = Standard temp X = Extended temp	E = SEC present N = SEC not present	7 = LCFC	K = 1000 MHz H = 800 MHz	N = 1300 MT/s K = 1000 MT/s Q = 1600 MT/s Z = Not specified	B = Rev 2.0

7.2 Orderable part numbers addressed by this document

This table provides the NXP orderable part numbers addressed by this document for the chip.

Table 146. Orderable part numbers addressed by this document

Part number/ marking on the chip	<i>p</i>	<i>ls</i>	<i>n</i>	<i>nn</i>	<i>n</i>	<i>x</i>	<i>t</i>	<i>e</i>	<i>n</i>	<i>c</i>	<i>d</i>	<i>r</i>
LS1020ASE 7KQB	blank	LS	1	02 = 2 core s (virt ual)	0	A = ARM	S = Std temp X = Ext temp	E = Encryp t N = Not Encryp t	7 = LCFC	K = 1000 MHz H = 800 MHz	N = 1300 MT/s Q = 1600 MT/s	B
LS1020AXE 7KQB												
LS1020ASN 7KQB												
LS1020AXN 7KQB												
LS1020ASE 7HNB												
LS1020AXE 7HNB												
LS1020ASN 7HNB												

Table 146. Orderable part numbers addressed by this document

Part number/ marking on the chip	<i>p</i>	<i>ls</i>	<i>n</i>	<i>nn</i>	<i>n</i>	<i>x</i>	<i>t</i>	<i>e</i>	<i>n</i>	<i>c</i>	<i>d</i>	<i>r</i>
LS1020AXN 7HNB												

7.2.1 Part marking

Parts are marked as in the example shown in this figure.

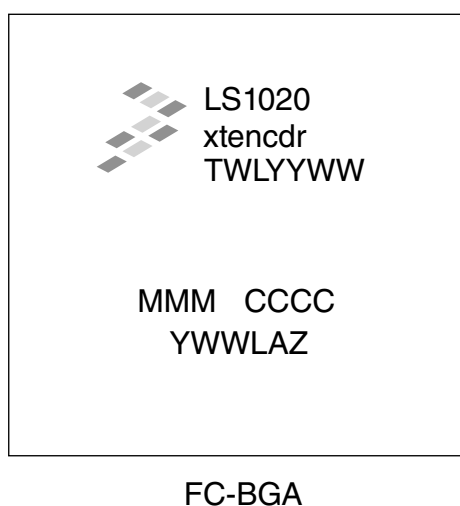

Legend:

LS1020xtencdr is the part marking on the die. See the corresponding orderable part number in the table above.

TWLYYWW is the test traceability code.

MMM is the mask number.

CCCC is the country code.

YWWLAZ is the assembly traceability code.

Figure 93. Part marking for FC-BGA chip (LS1020A)

8 Revision history

This table summarizes revisions to this document.

Table 147. Revision history

Revision	Date	Description
3	05/2016	<ul style="list-style-type: none"> Throughout document: <ul style="list-style-type: none"> Changed company references from Freescale to NXP within the body of the document content.

Table continues on the next page...

Table 147. Revision history (continued)

Revision	Date	Description
		<ul style="list-style-type: none"> • Renamed description for power supply TA_BB_VDD from "Low Powered Security Monitor supply" to Battery Backed Security Monitor supply." • Removed reference to signal TA_BB_RTC. • In Pinout list, <ul style="list-style-type: none"> • Changed name of "Trust" section to "Battery Backed Trust." • For signal TA_BB_RTC: <ul style="list-style-type: none"> • Changed signal description to "Reserved" • Applied note #15, "These pins must be pulled to ground (GND)." • For TA_BB_TMP_DETECT_B, changed signal description from "Low Power Tamper Detect" to "Battery Backed Tamper Detect" • For CKSTP_OUT_B, changed signal description to "Reserved" • For power supply TA_BB_VDD, changed description from "Low Power Security Monitor Supply" to "Battery Backed Security Monitor Supply" • Moved D1_MDM8 (B21), D1_MDQS8 (A21), D1_MDQS8_B(A20) from the reserved listing back to their active locations. • In Power sequencing, updated stable value from 75ms to 400ms and added step three to secure boot fuse programming sequence. • In Differential system clock DC electrical characteristics table, added note 3, "Input differential voltage swing (Vid) specified is equal to IVDIFF_SYSCLK_P - VDIFF_SYSCLK_NI." • In Differential system clock AC timing specifications table, added note 3, "The 100 MHz reference frequency is needed if USB is used. The reference clock to USB PHY is selectable between SYSCLK or DIFF_SYSCLK/DIF_SYSCLK_B. The selected clock must meet the clock specifications for USB."
2	02/2016	<ul style="list-style-type: none"> • In Features listing, removed "supports 1000Base KX" from SerDes feature list. • In Pinout list, added new note, "Permissible voltage range" to the USB1_VBUS pin. • In Recommended operating conditions, updated table and added the following sentence to table note #7, "This also applies to DVDD and D1VDD." • In Output driver capability table, added D1VDD to DVDD. • In Real-time clock recommendations table, added a "Typical value" column and updated min and max values. • In the table for Differential system clock DC electrical characteristics, updated min, max, and typical values for input capacitance and added note #2, "The die capacitance may cause reflection of the clock signal through the package back to the pin. This should not affect the signal quality seen by internal PLL. Recommend verifying signal quality using IBIS simulations." • RESET initialization timing specifications table, added new notes #5 & #6. • In EMI1 DC electrical characteristics, updated all tables: <ul style="list-style-type: none"> • Removed table note #2, "The symbol L1VIN, in this case, represents the L1VIN symbol referenced in Table 3." • Removed table note #3, " The symbol L1VDD, in this case, represents the L1VDD symbols referenced in Table 3." • Updated LVDD to L1VDD. • In USB 3.0 reference clock requirements : <ul style="list-style-type: none"> • Added a paragraph concerning the two options for USB PHY reference clock. • Removed rows pertaining to Common mode input level, Differential input swing, Single-ended input logic low, Single-ended input logic high, Input edge rate, and Reference clock skew from the Reference clock requirements table • In QuadSPI timing SDR mode, updated figure QuadSPI AC timing — SDR mode. • In eSDHC AC timing specifications, updated the following figures: <ul style="list-style-type: none"> • eSDHC DDR50/eMMC DDR mode input AC timing diagram • eSDHC DDR50/eMMC DDR mode output AC timing diagram

Table continues on the next page...

Table 147. Revision history (continued)

Revision	Date	Description
		<ul style="list-style-type: none"> In SATA DC transmitter output characteristics, updated title of table from Gen 3i transmitter DC specifications (S1VDD = 1.0 V)² to Gen 3i transmitter DC specifications (X1VDD = 1.35 V)² In Termination of unused signals, updated note #2 of figure, "JTAG interface connection," to read: "This switch is included as a precaution for IEEE 1149.1 testing."
1	11/2015	<ul style="list-style-type: none"> In Introduction updated block diagram. In DDR3L and DDR4 SDRAM interface AC timing specifications, added entries for 1000 MT/s data rate. In DDR3L and DDR4 SDRAM interface output AC timing specifications, added entries for 1000 MT/s data rate. Removed topic, DDR3L and DDR4 SDRAM differential timing specifications. In Part numbering nomenclature, changed the unit of measure for DDR data rate (column d) from MHz to MT/s. In Orderable part numbers addressed by this document, changed the unit of measure for DDR data rate (column d) from MHz to MT/s.
0	10/2015	Initial public release