

FEATURES

- Guaranteed 1% Initial Voltage Tolerance
- Guaranteed 0.01%/V Line Regulation
- Guaranteed 0.5% Load Regulation
- Guaranteed 0.02%/W Thermal Regulation
- 100% Burn-in in Thermal Limit

APPLICATIONS

- Adjustable Power Supplies
- System Power Supplies
- Precision Voltage/Current Regulators
- On-Card Regulators

DESCRIPTION

The LT[®]137A/LT337A negative adjustable regulators will deliver up to 1.5A output current over an output voltage range of -1.2V to -37V. Linear Technology has made significant improvements in these regulators compared to previous devices, such as better line and load regulation, and a maximum output voltage error of 1%.

Every effort has been made to make these devices easy to use and difficult to damage. Internal current and power limiting coupled with true thermal limiting prevents device damage due to overloads or shorts, even if the regulator is not fastened to a heat sink.

Maximum reliability is attained with Linear Technology's advanced processing techniques combined with a 100% burn-in in the thermal limit mode. This assures that all device protection circuits are working and eliminates field failures experienced with other regulators that receive only standard electrical testing.

LT, LT, LTC and LTM are registered trademarks of Linear Technology Corporation. All other trademarks are the property of their respective owners.

TYPICAL APPLICATION

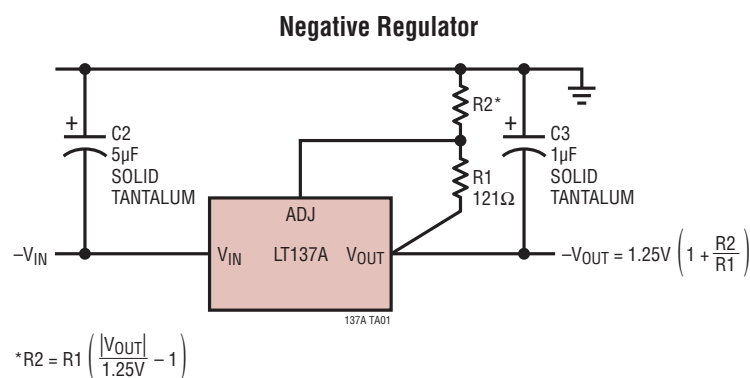

Output Voltage Error

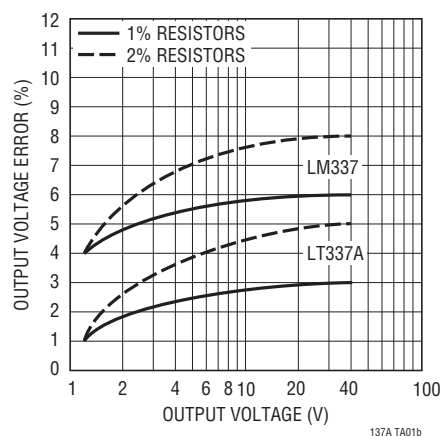

LT137A/LM137 LT337A/LM337

ABSOLUTE MAXIMUM RATINGS

(Note 1)

Power Dissipation Internally Limited
 Input to Output Voltage Differential 40V
 Operating Junction Temperature Range
 LT137A/LM137 -55°C to 150°C
 LT337A/LM337 0°C to 125°C
 Storage Temperature Range
 LT137A/LM137 -65°C to 150°C
 LT337A/LM337 -65°C to 150°C
 Lead Temperature (Soldering, 10 sec.) 300°C

PRECONDITIONING

100% Thermal Limit Burn-In

PIN CONFIGURATION

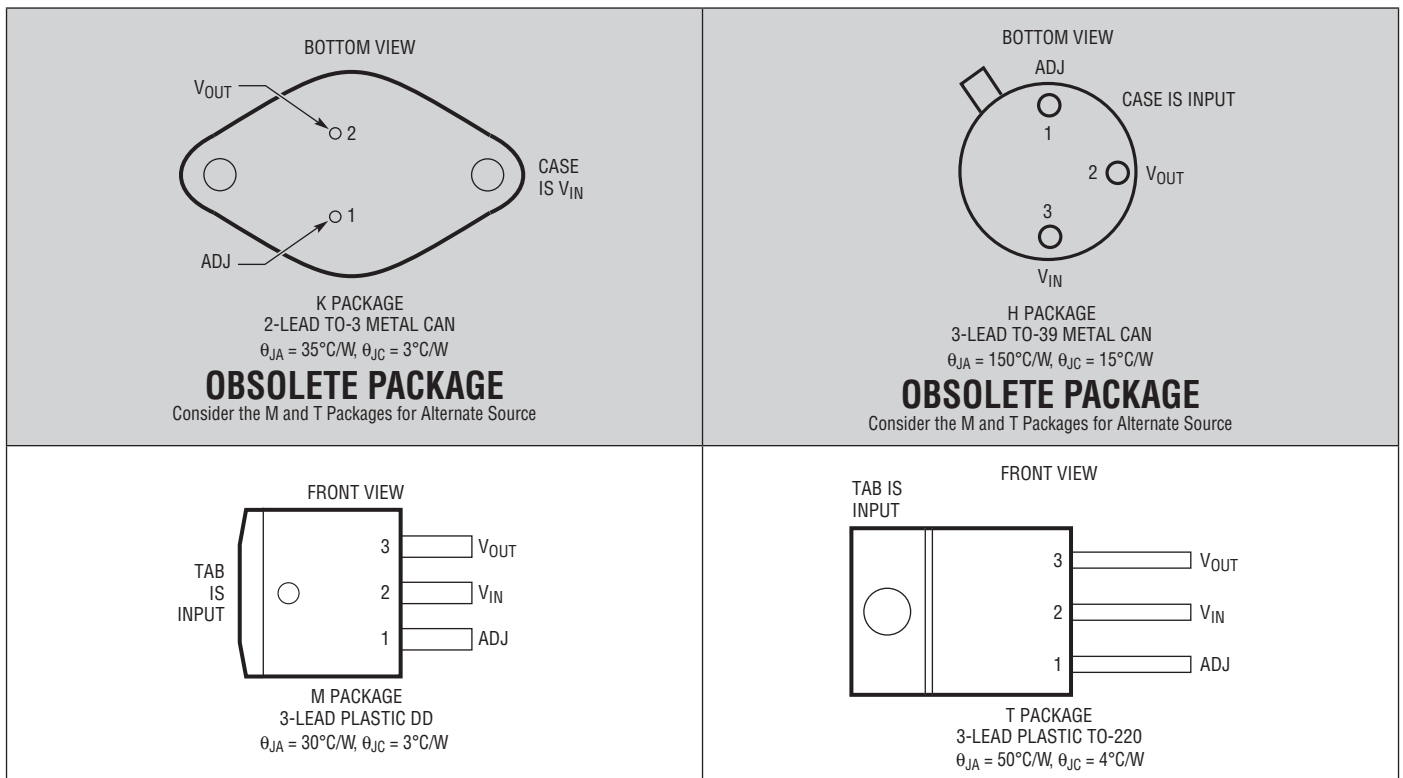

ORDER INFORMATION

LEAD FREE FINISH	TAPE AND REEL	PART MARKING*	PACKAGE DESCRIPTION	TEMPERATURE RANGE
LT337AM#PBF	LT337AM#TRPBF	LT337AM	3-Lead Plastic DD	0°C to 125°C
LT337AT#PBF	LT337AT#TRPBF	LT337AT	3-Lead Plastic TO-220	0°C to 125°C
LM337T#PBF	LM337T#TRPBF	LM337T	3-Lead Plastic TO-220	0°C to 125°C
LEAD BASED FINISH	TAPE AND REEL	PART MARKING*	PACKAGE DESCRIPTION	TEMPERATURE RANGE
LT337AM	LT337AM#TR	LT337AM	3-Lead Plastic DD	0°C to 125°C
LT337AT	LT337AT#TR	LT337AT	3-Lead Plastic TO-220	0°C to 125°C

137afb

ORDER INFORMATION

LEAD BASED FINISH	TAPE AND REEL	PART MARKING	PACKAGE DESCRIPTION	TEMPERATURE RANGE
LM337T	LM337T#TR	LM337T	3-Lead Plastic TO-220	0°C to 125°C

Consult LTC Marketing for parts specified with wider operating temperature ranges. *The temperature grade is identified by a label on the shipping container. Consult LTC Marketing for information on non-standard lead based finish parts.

For more information on lead free part marking, go to: <http://www.linear.com/leadfree/>

For more information on tape and reel specifications, go to: <http://www.linear.com/tapeandreel/>

ELECTRICAL CHARACTERISTICS

The ● denotes the specifications which apply over the full operating temperature range, otherwise specifications are at $T_A = 25^\circ\text{C}$. (Notes 2, 3)

SYMBOL	PARAMETER	CONDITIONS	LT137A			LM137			UNITS
			MIN	TYP	MAX	MIN	TYP	MAX	
V_{REF}	Reference Voltage	$ V_{IN} - V_{OUT} = 5V, I_{OUT} = 10\text{mA}, T_j = 25^\circ\text{C}$	-1.238	-1.250	-1.262	-1.225	-1.250	-1.275	V
		$3V \leq V_{IN} - V_{OUT} \leq 40V$ $10\text{mA} \leq I_{OUT} \leq I_{MAX}, P \leq P_{MAX}$	● -1.220	-1.250	-1.280	-1.200	-1.250	-1.300	V
$\frac{\Delta V_{OUT}}{\Delta I_{OUT}}$	Load Regulation	$10\text{mA} \leq I_{OUT} \leq I_{MAX}$, (Note 4) $T_j = 25^\circ\text{C}, V_{OUT} \leq 5V$		5	25		15	25	mV
		$T_j = 25^\circ\text{C}, V_{OUT} \geq 5V$		0.1	0.5		0.3	0.5	%
		$ V_{OUT} \leq 5V$	●	10	50	●	20	50	mV
		$ V_{OUT} \geq 5V$	●	0.2	1	●	0.3	1	%
$\frac{\Delta V_{OUT}}{\Delta V_{IN}}$	Line Regulation	$3V \leq V_{IN} - V_{OUT} \leq 40V$ (Note 4) $T_j = 25^\circ\text{C}$	●	0.005	0.01		0.01	0.02	%/V
				0.01	0.03		0.02	0.05	%/V
	Ripple Rejection	$V_{OUT} = -10V, f = 120\text{Hz}$ $C_{ADJ} = 0$ $C_{ADJ} = 10\mu\text{F}$	●	60 70	66 80		66 77		dB dB
	Thermal Regulation	$T_j = 25^\circ\text{C}, 10\text{ms Pulse}$		0.002	0.02		0.002	0.02	%/W
I_{ADJ}	Adjust Pin Current		●	65	100		65	100	μA
ΔI_{ADJ}	Adjust Pin Current Change	$10\text{mA} \leq I_{OUT} \leq I_{MAX}$ $3V \leq V_{IN} - V_{OUT} \leq 40V$	●	0.2	2		0.5	5	μA
			●	1	5		2	5	μA
	Minimum Load Current	$ V_{IN} - V_{OUT} \leq 40V$	●	2.5	5		2.5	5	mA
		$ V_{IN} - V_{OUT} \leq 10V$	●	1.2	3		1.2	3	mA
I_{SC}	Current Limit	$ V_{IN} - V_{OUT} \leq 15V$, K and T Package (Note 7)	●	1.5	2.2		1.5	2.2	A
		H Package	●	0.5	0.8		0.5	0.8	A
		$ V_{IN} - V_{OUT} = 40V$, K and T Package		0.24	0.4		0.24	0.4	A
		$T_j = 25^\circ\text{C}$ H Package		0.15	0.25		0.15	0.25	A
$\frac{\Delta V_{OUT}}{\Delta \text{Temp}}$	Temperature Stability of Output Voltage (Note 6)	$T_{MIN} \leq T \leq T_{MAX}$	●	0.6	1.5		0.6		%
$\frac{\Delta V_{OUT}}{\Delta \text{Time}}$	Long Term Stability	$T_A = 125^\circ\text{C}, 1000 \text{Hours}$		0.3	1		0.3	1	%
e_n	RMS Output Noise (% of V_{OUT})	$T_A = 25^\circ\text{C}, 10\text{Hz} \leq f \leq 10\text{kHz}$		0.003			0.003		%
θ_{JC}	Thermal Resistance Junction to Case	H Package		12	15		12	15	$^\circ\text{C/W}$
		K Package		2.3	3		2.3	3	$^\circ\text{C/W}$

LT137A/LM137 LT337A/LM337

ELECTRICAL CHARACTERISTICS

The ● denotes the specifications which apply over the full operating temperature range, otherwise specifications are at $T_A = 25^\circ\text{C}$. (Notes 2, 3)

SYMBOL	PARAMETER	CONDITIONS	LT337A			LM337			UNITS
			MIN	TYP	MAX	MIN	TYP	MAX	
V_{REF}	Reference Voltage	$ V_{IN} - V_{OUT} = 5\text{V}$, $I_{OUT} = 10\text{mA}$, $T_j = 25^\circ\text{C}$	-1.238	-1.250	-1.262	-1.213	-1.250	-1.287	V
		$3\text{V} \leq V_{IN} - V_{OUT} \leq 40\text{V}$ $10\text{mA} \leq I_{OUT} \leq I_{MAX}$, $P \leq P_{MAX}$	● -1.220	-1.250	-1.280	-1.200	-1.250	-1.300	V
$\frac{\Delta V_{OUT}}{\Delta I_{OUT}}$	Load Regulation	$10\text{mA} \leq I_{OUT} \leq I_{MAX}$, (Notes 4 and 5) $T_j = 25^\circ\text{C}$, $ V_{OUT} \leq 5\text{V}$		5	25		15	50	mV
		$T_j = 25^\circ\text{C}$, $ V_{OUT} \geq 5\text{V}$		0.1	0.5		0.3	1	%
		$ V_{OUT} \leq 5\text{V}$	●	10	50		20	70	mV
		$ V_{OUT} \geq 5\text{V}$	●	0.2	1		0.3	1.5	%
$\frac{\Delta V_{OUT}}{\Delta V_{IN}}$	Line Regulation	$3\text{V} \leq V_{IN} - V_{OUT} \leq 40\text{V}$ (Note 4) $T_j = 25^\circ\text{C}$		0.005	0.01		0.01	0.04	%/V
			●	0.01	0.03		0.02	0.07	%/V
	Ripple Rejection	$V_{OUT} = -10\text{V}$, $f = 120\text{Hz}$ $C_{ADJ} = 0$ $C_{ADJ} = 10\mu\text{F}$		60 70	66 80		60 66	77	dB dB
	Thermal Regulation	$T_j = 25^\circ\text{C}$, 10ms Pulse		0.002	0.02		0.003	0.04	%/W
I_{ADJ}	Adjust Pin Current		●	65	100		65	100	μA
ΔI_{ADJ}	Adjust Pin Current Change	$10\text{mA} \leq I_{OUT} \leq I_{MAX}$ $3\text{V} \leq V_{IN} - V_{OUT} \leq 40\text{V}$	●	0.2	2		0.5	5	μA
			●	1	5		2	5	μA
	Minimum Load Current	$ V_{IN} - V_{OUT} \leq 40\text{V}$	●	2.5	5		2.5	10	mA
		$ V_{IN} - V_{OUT} \leq 10\text{V}$	●	1.2	3		1	6	mA
I_{SC}	Current Limit	$ V_{IN} - V_{OUT} \leq 15\text{V}$, K, M and T Package	●	1.5	2.2		1.5	2.2	A
		H Package	●	0.5	0.8		0.5	0.8	A
		$ V_{IN} - V_{OUT} = 40\text{V}$, K, M and T Package		0.24	0.5		0.15	0.4	A
		$T_j = 25^\circ\text{C}$ H Package		0.15	0.25		0.1	0.17	A
$\frac{\Delta V_{OUT}}{\Delta \text{Temp}}$	Temperature Stability of Output Voltage (Note 6)		●	0.6	1.5		0.6		%
$\frac{\Delta V_{OUT}}{\Delta \text{Time}}$	Long Term Stability	$T_A = 125^\circ\text{C}$, 1000 Hours		0.3	1		0.3	1	%
e_n	RMS Output Noise (% of V_{OUT})	$T_A = 25^\circ\text{C}$, $10\text{Hz} \leq f \leq 10\text{kHz}$		0.003			0.003		%
θ_{JC}	Thermal Resistance Junction to Case	H Package		12	15		12	15	$^\circ\text{C}/\text{W}$
		K Package		2.3	3		2.3	3	$^\circ\text{C}/\text{W}$
		M and T Package		3	5		3	5	$^\circ\text{C}/\text{W}$

Note 1: Stresses beyond those listed under Absolute Maximum Ratings may cause permanent damage to the device. Exposure to any Absolute Maximum Rating condition for extended periods may affect device reliability and lifetime.

Note 2: The shaded electrical specifications indicate those parameters which have been improved or guaranteed test limits provided for the first time.

Note 3: Unless otherwise indicated, these specifications apply: $|V_{IN} - V_{OUT}| = 5\text{V}$; and $I_{OUT} = 0.1\text{A}$ for the H package, $I_{OUT} = 0.5\text{A}$ for the K, M, and T packages. Power dissipation is internally limited. However, these specifications apply for power dissipation up to 2W for the H package and 20W for the K and T packages. $I_{MAX} = 1.5\text{A}$ for the K, M, and T packages, and 0.2A for the H package.

Note 4: Testing is done using a pulsed low duty cycle technique. See thermal regulation specifications for output changes due to heating effects. Load regulation is measured on the output pin at a point 1/8" below the base of the K and H package and at the junction of the wide and narrow portion of the lead on the M and T package.

Note 5: Load regulation for the LT337AT is the same as for LM337T.

Note 6: Guaranteed on LT137A and LT337A, but not 100% tested in production.

Note 7: I_{SC} is tested at the ambient temperatures of 25°C and -55°C . I_{SC} cannot be tested at the maximum ambient temperature of 150°C due to the high power level required. I_{SC} specification at 150°C ambient is guaranteed by characterization and correlation to 25°C testing.

TYPICAL PERFORMANCE CHARACTERISTICS

Dropout Voltage

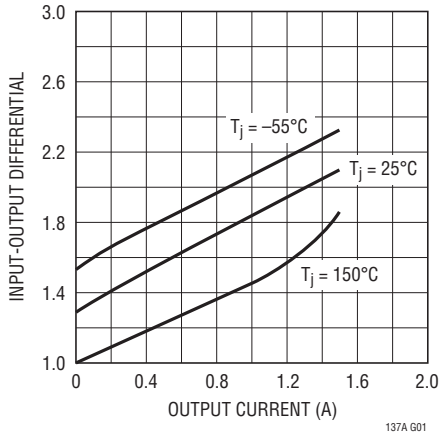

Temperature Stability

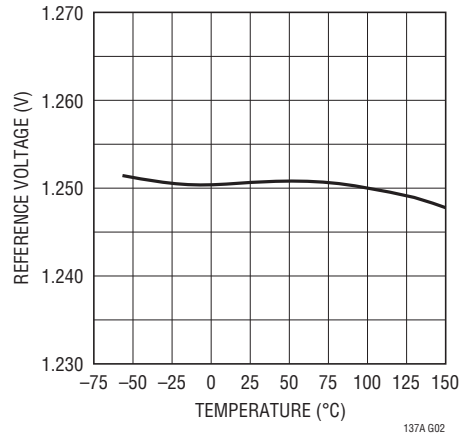

Minimum Load Current

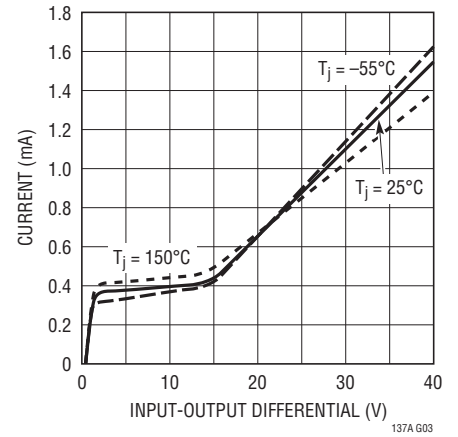

Ripple Rejection

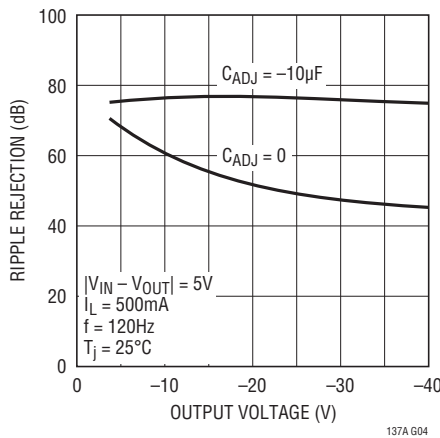

Ripple Rejection

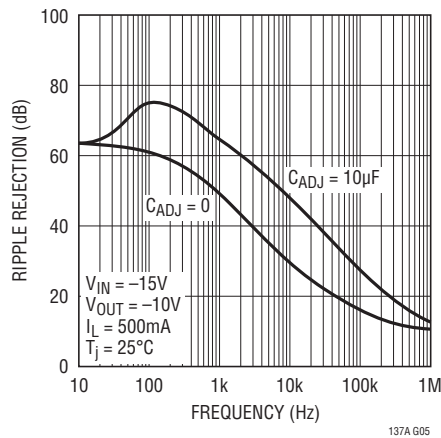

Ripple Rejection

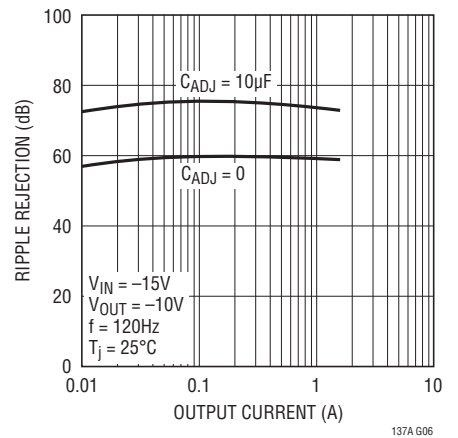

TYPICAL PERFORMANCE CHARACTERISTICS

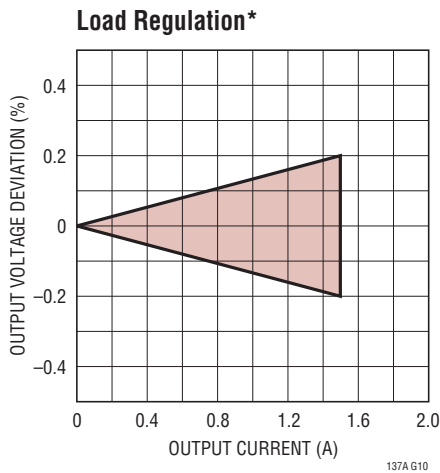
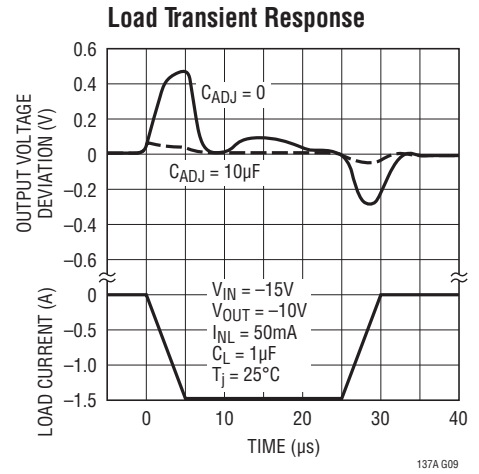
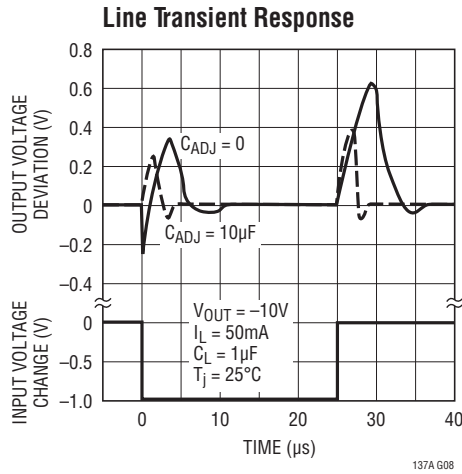
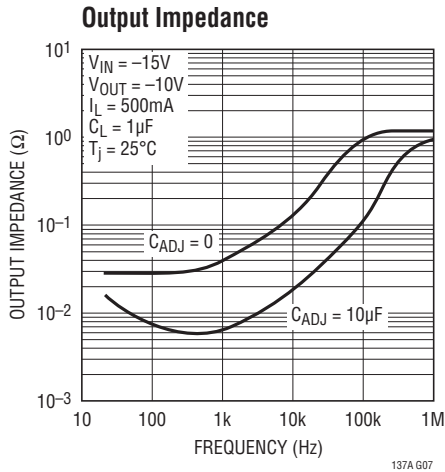

*THE LT137A/LT337A HAS LOAD REGULATION COMPENSATION WHICH MAKES THE TYPICAL UNIT READ CLOSE TO ZERO. THIS BAND REPRESENTS THE TYPICAL PRODUCTION SPREAD.

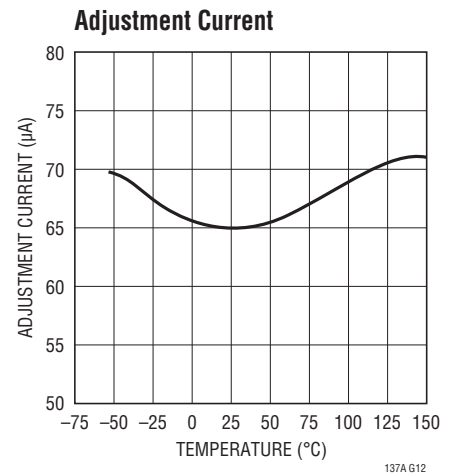
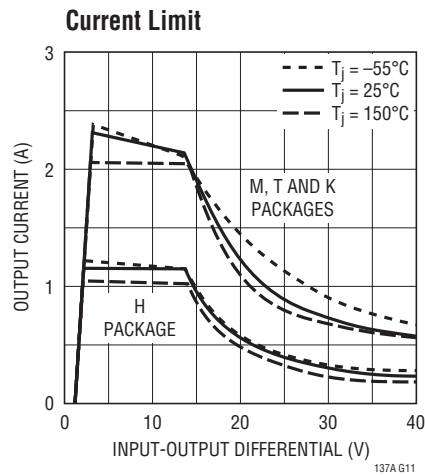

APPLICATIONS INFORMATION

Output Voltage

The output voltage is determined by two external resistors, R1 and R2 (see Figure 1). The exact formula for the output voltage is:

$$V_{OUT} = V_{REF} \left(1 + \frac{R2}{R1} \right) + I_{ADJ}(R2)$$

Where: V_{REF} = Reference Voltage, I_{ADJ} = Adjustment Pin Current. In most applications, the second term is small enough to be ignored, typically about 0.5% of V_{OUT} . In more critical applications, the exact formula should be used, with I_{ADJ} equal to $65\mu\text{A}$. Solving for R2 yields:

$$R2 = \frac{V_{OUT} - V_{REF}}{\frac{V_{REF}}{R1} + I_{ADJ}}$$

Smaller values of R1 and R2 will reduce the influence of I_{ADJ} on the output voltage, but the no-load current drain on the regulator will be increased. Typical values for R1 are between 100Ω and 300Ω , giving 12.5mA and 4.2mA no-load current respectively. There is an additional consideration in selecting R1, the minimum load current specification of the regulator. The operating current of the LT137A flows from input to output. If this current is not absorbed by the load, the output of the regulator will rise above the regulated value. The current drawn by R1 and R2 is normally high enough to absorb the current, but care must be taken in no-load situations where R1 and R2 have high values.

The maximum value for the operating current, which must be absorbed, is 5mA for the LT137A. If input-output voltage differential is less than 10V , the operating current that must be absorbed drops to 3mA .

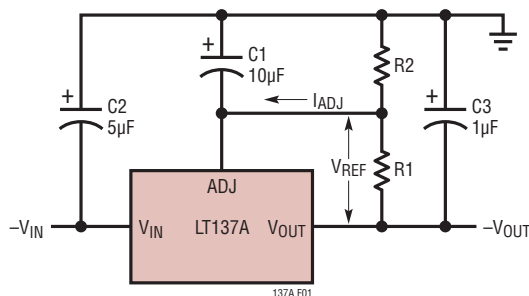

Figure 1

EXAMPLES:

1. A precision 10V regulator to supply up to 1A load current.
 - a. Select $R1 = 100\Omega$ to minimize effect of I_{ADJ}
 - b. Calculate $R2 =$

$$\frac{V_{OUT} - V_{REF}}{\frac{V_{REF}}{R1} + I_{ADJ}} = \frac{10\text{V} - 1.25\text{V}}{\frac{1.25\text{V}}{100\Omega} + 65\mu\text{A}} = 696.4\Omega$$

Use $R2 = 698\Omega$

2. A 15V regulator to run off batteries and supply 50mA . $V_{IN\text{ MAX}} = 25\text{V}$

- a. To minimize battery drain, select R1 as high as possible

$$R1 = \frac{1.25\text{V}}{3\text{mA}} = 417\Omega, \text{ use } 402\Omega, 1\%$$

- b. The high value for R1 will exaggerate the error due to I_{ADJ} , so the exact formula to calculate R2 should be used.

$$R2 = \frac{V_{OUT} - V_{REF}}{\frac{V_{REF}}{R1} + I_{ADJ}} = \frac{15\text{V} - 1.25\text{V}}{\frac{1.25\text{V}}{402\Omega} + 65\mu\text{A}} = 4331\Omega$$

Use $R2 = 4320\Omega$

Capacitors and Protection Diodes

An output capacitor, C3, is required to provide proper frequency compensation of the regulator feedback loop. A $1\mu\text{F}$ or larger solid tantalum capacitor is generally sufficient for this purpose if the 1MHz impedance of the capacitor is 2Ω or less. High Q capacitors, such as Mylar, are not recommended because they tend to reduce the phase margin at light load currents. Aluminum electrolytic capacitors may also be used, but the minimum value should be $10\mu\text{F}$ to ensure a low impedance at 1MHz . The output capacitor should be located within a few inches of the regulator to keep lead impedance to a minimum. The following caution should be noted: if the output voltage is greater than 6V and an output capacitor greater than $20\mu\text{F}$ has been used, it is possible to damage the regulator if the input voltage

APPLICATIONS INFORMATION

becomes shorted, due to the output capacitor discharging into the regulator. This can be prevented by using the diode D1 (see Figure 2) between the input and the output.

The input capacitor, C2, is only required if the regulator is more than 4 inches from the raw supply filter capacitor.

Bypassing the Adjustment Pin

The adjustment pin of the LT137A may be bypassed with a capacitor to ground, C1, to reduce output ripple, noise, and impedance. These parameters scale directly with output voltage if the adjustment pin is not bypassed. A bypass capacitor reduces ripple, noise, and impedance to that of a 1.25V regulator. In a 15V regulator, for example, these parameters are improved by $15V/1.25V = 12$ to 1. This improvement holds only for those frequencies where the impedance of the bypass capacitor is less than R1. Ten microfarads is generally sufficient for 60Hz power line applications where the ripple frequency is 120Hz since $X_C = 130\Omega$. The capacitor should have a voltage rating at least as high as the output voltage of the regulator. Values larger than $10\mu F$ may be used, but if the output is larger than 25V, a diode, D2, should be added between the output and adjustment pins (see Figure 2).

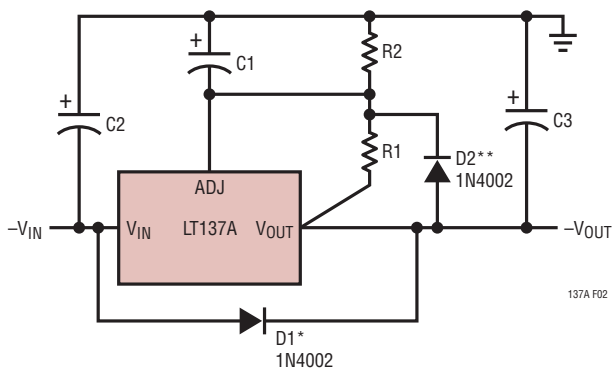

*D1 PROTECTS THE REGULATOR FROM INPUT SHORTS TO GROUND. IT IS REQUIRED ONLY WHEN C3 IS LARGER THAN $20\mu F$ AND V_{OUT} IS LARGER THAN 6V.

**D2 PROTECTS THE ADJUST PIN OF THE REGULATOR FROM OUTPUT SHORTS IF C2 IS LARGER THAN $10\mu F$ AND V_{OUT} IS LARGER THAN -25V.

Figure 2

Proper Connection of Divider Resistors

The LT137A has an excellent load regulation specification of 0.5% and is measured at a point 1/8" from the bottom of the package. To prevent degradation of load regulation, the resistors which set output voltage, R1 and R2, must be connected as shown in Figure 3. Note that the positive side of the load has a true force and sense (Kelvin) connection, but the negative side of the load does not.

R1 should be connected directly to the output lead of the regulator, as close as possible to the specified point 1/8" from the case. R2 should be connected to the positive side of the load separately from the positive (ground) connection to the raw supply. With this arrangement, load regulation is degraded only by the resistance between the regulator output pin and the load. If R1 is connected to the load, regulation will be degraded.

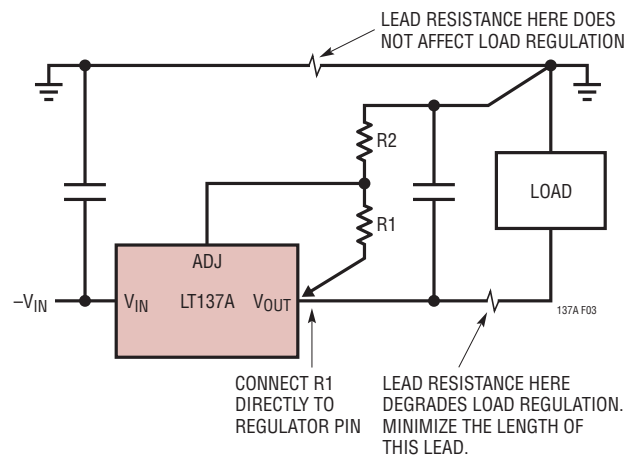

Figure 3

TYPICAL APPLICATIONS

A high stability regulator is illustrated in the application circuit shown to the right. The output stability, load regulation, line regulation, thermal regulation, temperature drift, long term drift, and noise can be improved by a factor of 6.6 over the standard regulator configuration. This assumes a zener whose drift and noise is considerably better than the regulator itself. The LM329B has 20ppm/°C maximum drift and about 10 times lower noise than the regulator.

In the application shown below, regulators #2 to “N” will track regulator #1 to within ±24mV initially, and to ±60mV over all load, line, and temperature conditions. If any regulator output is shorted to ground, all other outputs will drop to approximately $\approx -2V$. Load regulation of regulators 2 to “N” will be improved by $V_{OUT}/1.25V$ compared to a standard regulator, so regulator #1 should be the one which has the lowest load current.

High Stability Regulator

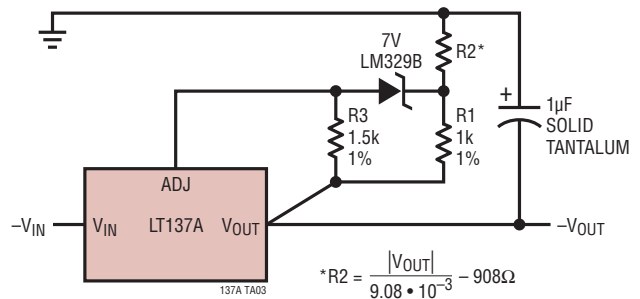

Dual Tracking Supply ±1.25V to ±20V

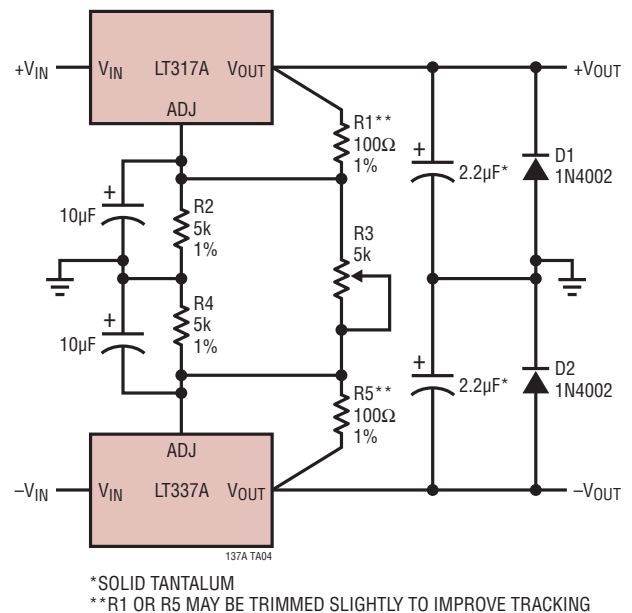

Multiple Tracking Regulators

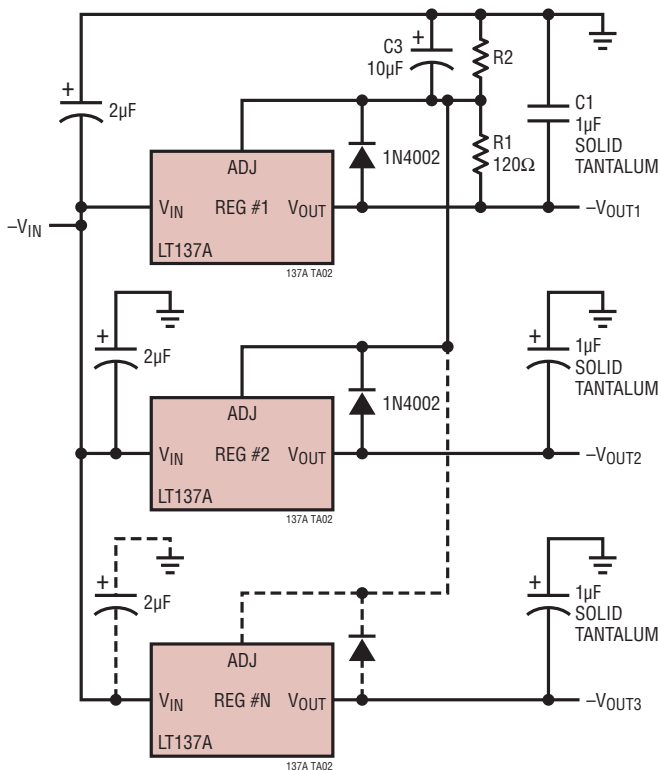

Current Regulator

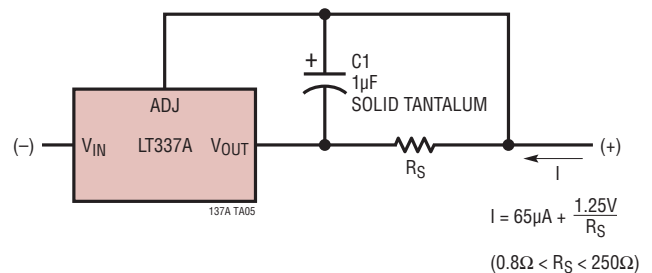

LT137A/LM137
LT337A/LM337

SCHEMATIC DIAGRAM

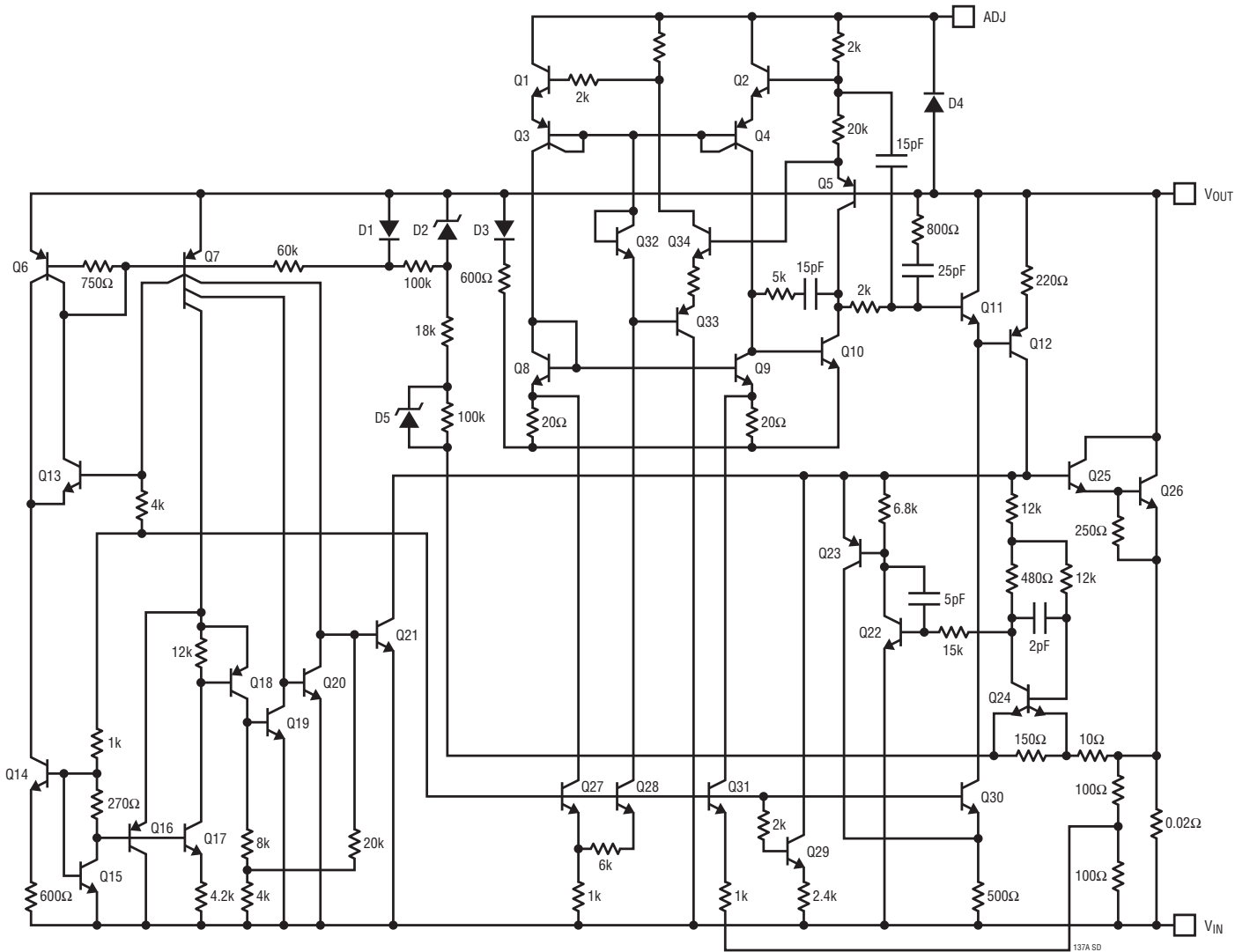

PACKAGE DESCRIPTION

OBSOLETE PACKAGES

H Package
3-Lead TO-39 Metal Can
 (Reference LTC DWG # 05-08-1330)

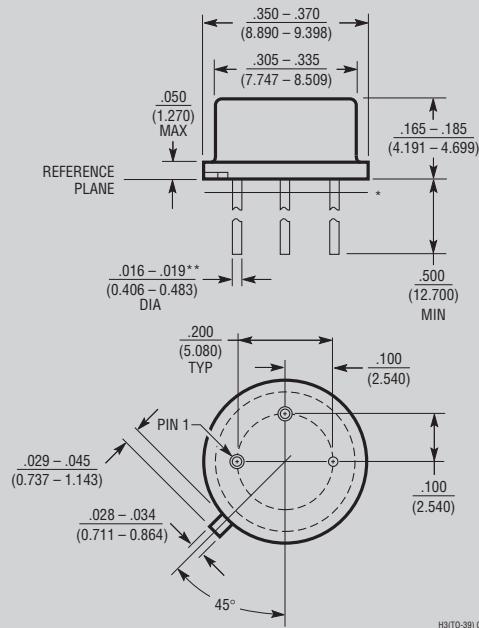

*LEAD DIAMETER IS UNCONTROLLED BETWEEN THE REFERENCE PLANE AND $.050$ " BELOW THE REFERENCE PLANE

**FOR SOLDER DIP LEAD FINISH, LEAD DIAMETER IS $.016 - .024$ (0.406 - 0.610)

K Package
2-Lead TO-3 Metal Can
 (Reference LTC DWG # 05-08-1310)

