

FEATURES

- True Color PWM™ Delivers Constant Color with 3000:1 Dimming Range
- Wide Input Range: 4V to 36V Operating, 40V Maximum
- Accurate and Adjustable Control of LED Current from 50mA to 1.5A
- High Side Current Sense Allows Grounded Cathode LED Operation
- Open LED (LT3475) and Short Circuit Protection
- LT3475-1 Drives LED Strings Up to 25V
- Accurate and Adjustable 200kHz to 2MHz Switching Frequency
- Anti-Phase Switching Reduces Ripple
- Uses Small Inductors and Ceramic Capacitors
- Available in the Compact 20-Lead TSSOP Thermally Enhanced Surface Mount Package

APPLICATIONS

- Automotive and Avionic Lighting
- Architectural Detail Lighting
- Display Backlighting
- Constant-Current Sources

LT, LT, LTC and LTM are registered trademarks of Linear Technology Corporation. All other trademarks are the property of their respective owners. Patents Pending.

DESCRIPTION

The LT®3475/LT3475-1 are dual step-down DC/DC converters designed to operate as a constant-current source. An internal sense resistor monitors the output current allowing accurate current regulation ideal for driving high current LEDs. The high side current sense allows grounded cathode LED operation. High output current accuracy is maintained over a wide current range, from 50mA to 1.5A, allowing a wide dimming range. Unique PWM circuitry allows a dimming range of 3000:1, avoiding the color shift normally associated with LED current dimming.

The high switching frequency offers several advantages, permitting the use of small inductors and ceramic capacitors. Small inductors combined with the 20 lead TSSOP surface mount package save space and cost versus alternative solutions. The constant switching frequency combined with low-impedance ceramic capacitors result in low, predictable output ripple.

With its wide input range of 4V to 36V, the LT3475/LT3475-1 regulate a broad array of power sources. A current mode PWM architecture provides fast transient response and cycle-by-cycle current limiting. Frequency foldback and thermal shutdown provide additional protection.

TYPICAL APPLICATION

Dual Step-Down 1.5A LED Driver

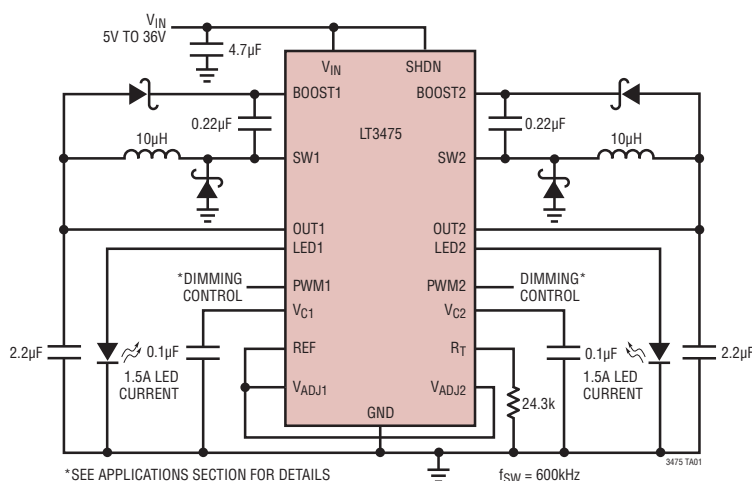

Efficiency

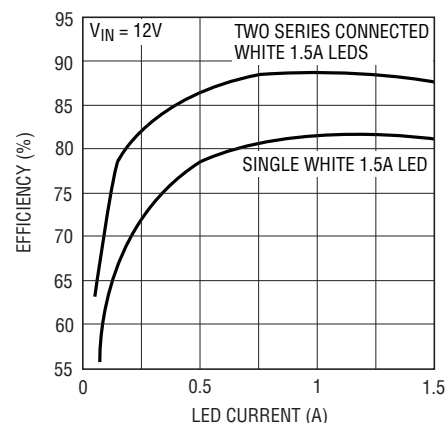

LT3475/LT3475-1

ABSOLUTE MAXIMUM RATINGS

(Note 1)

V_{IN} Pin	(-0.3V), 40V
BOOST Pin Voltage	60V
BOOST Above SW Pin.....	30V
OUT, LED, Pins (LT3475).....	15V
OUT, LED Pins (LT3475-1).....	25V
PWM Pin.....	15V
V_{ADJ} Pin.....	6V
V_C , R_T , REF Pins	3V
SHDN Pin.....	V_{IN}
Maximum Junction Temperature (Note 2).....	125°C
Operating Temperature Range (Note 3)	
LT3475E/LT3475E-1	-40°C to 85°C
LT3475I/LT3475I-1.....	-40°C to 125°C
Storage Temperature Range.....	-65°C to 150°C
Lead Temperature Range (Soldering, 10 sec)	300°C

PIN CONFIGURATION

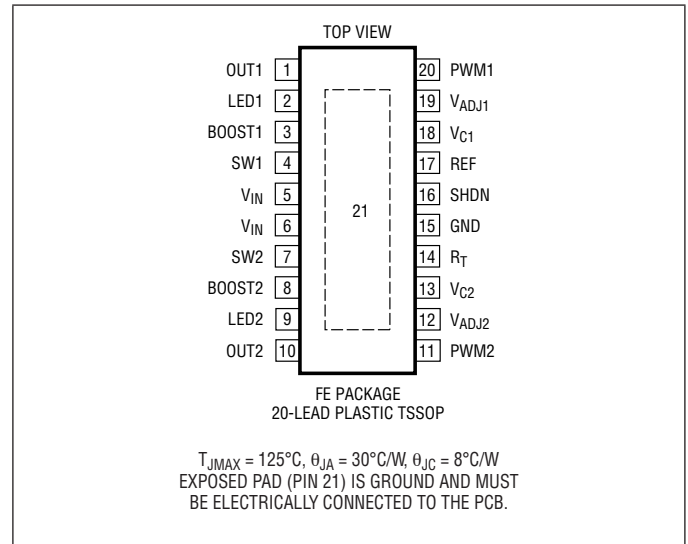

ORDER INFORMATION

LEAD FREE FINISH	TAPE AND REEL	PART MARKING*	PACKAGE DESCRIPTION	TEMPERATURE RANGE
LT3475EFE#PBF	LT3475EFE#TRPBF	LT3475EFE	20-Lead Plastic TSSOP	-40°C to 85°C
LT3475IFE#PBF	LT3475IFE#TRPBF	LT3475IFE	20-Lead Plastic TSSOP	-40°C to 125°C
LT3475EFE-1#PBF	LT3475EFE-1#TRPBF	LT3475FE-1	20-Lead Plastic TSSOP	-40°C to 85°C
LT3475IFE-1#PBF	LT3475IFE-1#TRPBF	LT3475FE-1	20-Lead Plastic TSSOP	-40°C to 125°C

Consult LTC Marketing for parts specified with wider operating temperature ranges. *The temperature grade is identified by a label on the shipping container. Consult LTC Marketing for information on non-standard lead based finish parts.

For more information on lead free part marking, go to: <http://www.linear.com/leadfree/>

For more information on tape and reel specifications, go to: <http://www.linear.com/tapeandreeel/>

ELECTRICAL CHARACTERISTICS

The ● denotes the specifications which apply over the full operating temperature range, otherwise specifications are at $T_A = 25^\circ\text{C}$. $V_{IN} = 12\text{V}$, $V_{BOOST} = 16\text{V}$, $V_{OUT} = 4\text{V}$ unless otherwise noted (Note 3)

PARAMETER	CONDITIONS	MIN	TYP	MAX	UNITS
Minimum Input Voltage		●	3.7	4	V
Input Quiescent Current	Not Switching		6	8	mA
Shutdown Current	SHDN = 0.3V, $V_{BOOST} = V_{OUT} = 0\text{V}$		0.01	2	μA

ELECTRICAL CHARACTERISTICS The ● denotes the specifications which apply over the full operating temperature range, otherwise specifications are at $T_A = 25^\circ\text{C}$. $V_{IN} = 12\text{V}$, $V_{BOOST} = 16\text{V}$, $V_{OUT} = 4\text{V}$ unless otherwise noted (Note 3)

PARAMETER	CONDITIONS	MIN	TYP	MAX	UNITS	
LED Pin Current	V_{ADJ} Tied to $V_{REF} \cdot 2/3$ V_{ADJ} Tied to $V_{REF} \cdot 7/30$ LT3475E/LT3475E-1 0°C to 85°C	● 0.97	1.00	1.03	A	
		0.94		1.04	A	
		0.336	0.350	0.364	A	
		0.325		0.375	A	
		● 0.31		0.385	A	
REF Voltage		● 1.22	1.25	1.27	V	
Reference Voltage Line Regulation	$4\text{V} < V_{IN} < 40\text{V}$		0.05		%/V	
Reference Voltage Load Regulation	$0 < I_{REF} < 500\mu\text{A}$		0.0002		%/ μA	
V_{ADJ} Pin Bias Current (Note 4)		●	40	400	nA	
Switching Frequency	$R_T = 24.3\text{k}$	● 530	600	640	kHz	
Maximum Duty Cycle	$R_T = 24.3\text{k}$ $R_T = 4.32\text{k}$ $R_T = 100\text{k}$	● 90	95		%	
			80		%	
			98		%	
Switching Phase	$R_T = 24.3\text{k}$		150	180	210	Deg
Foldback Frequency	$R_T = 24.3\text{k}$, $V_{OUT} = 0\text{V}$		80			kHz
SHDN Threshold (to Switch)		2.5	2.6	2.74	V	
SHDN Pin Current (Note 5)	$V_{SHDN} = 2.6\text{V}$	7	9	11	μA	
PWM Threshold		0.3	0.8	1.2	V	
V_C Switching Threshold			0.8		V	
V_C Source Current	$V_C = 1\text{V}$		50		μA	
V_C Sink Current	$V_C = 1\text{V}$		50		μA	
LED to V_C Transresistance			500		V/A	
LED to V_C Current Gain			1		mA/ μA	
V_C to Switch Current Gain			2.6		A/V	
V_C Clamp Voltage			1.8		V	
V_C Pin Current in PWM Mode	$V_C = 1\text{V}$, $V_{PWM} = 0.3\text{V}$	●	10	400	nA	
OUT Pin Clamp Voltage (LT3475)		13.5	14	14.5	V	
OUT Pin Current in PWM Mode	$V_{OUT} = 4\text{V}$, $V_{PWM} = 0.3\text{V}$	●	25	50	μA	
Switch Current Limit (Note 6)		2.3	2.7	3.2	A	
Switch V_{CESAT}	$I_{SW} = 1.5\text{A}$		350	500	mV	
BOOST Pin Current	$I_{SW} = 1.5\text{A}$		25	40	mA	
Switch Leakage Current			0.1	10	μA	
Minimum Boost Voltage Above SW			1.8	2.5	V	

Note 1: Stresses beyond those listed under Absolute Maximum Ratings may cause permanent damage to the device. Exposure to any Absolute Maximum Rating condition for extended periods may affect device reliability and lifetime.

Note 2: This IC includes overtemperature protection that is intended to protect the device during momentary overload conditions. Junction temperature will exceed 125°C when overtemperature protection is active. Continuous operation above the specified maximum operating junction temperature may impair device reliability.

Note 3: The LT3475E and LT3475E-1 are guaranteed to meet performance specifications from 0°C to 85°C . Specifications over the -40°C to 85°C operating temperature range are assured by design, characterization and correlation with statistical process controls. The LT3475I and LT3475I-1 are guaranteed to meet performance specifications over the -40°C to 125°C operating temperature range.

Note 4: Current flows out of pin.

Note 5: Current flows into pin.

Note 6: Current limit is guaranteed by design and/or correlation to static test. Slope compensation reduces current limit at higher duty cycles.

TYPICAL PERFORMANCE CHARACTERISTICS

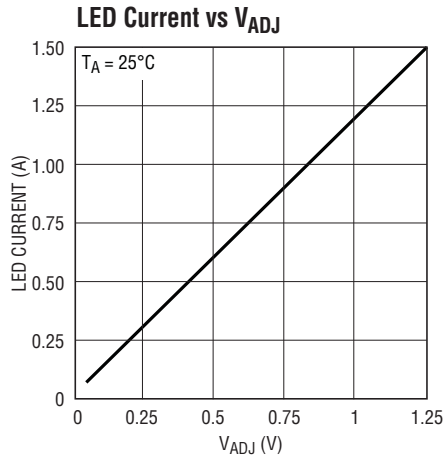

3475 G01

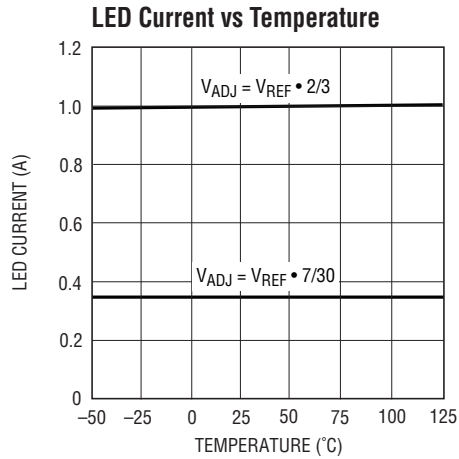

3475 G02

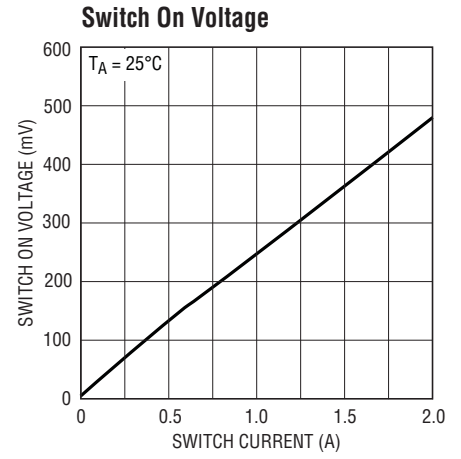

3475 G03

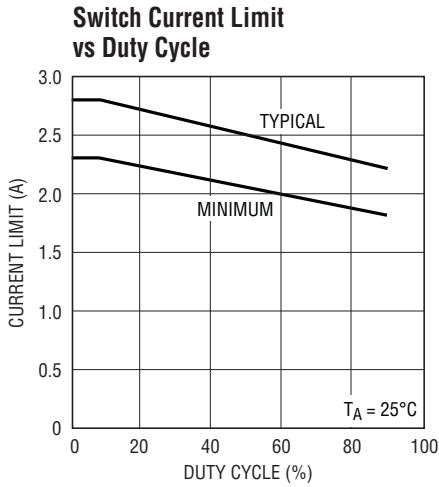

3475 G04

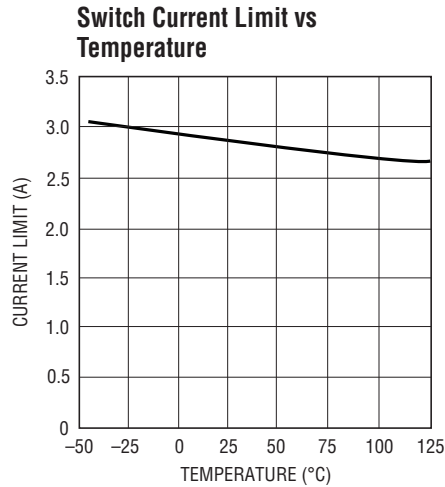

3475 G05

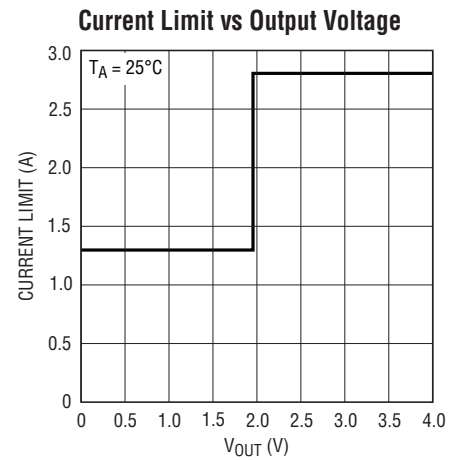

3475 G06

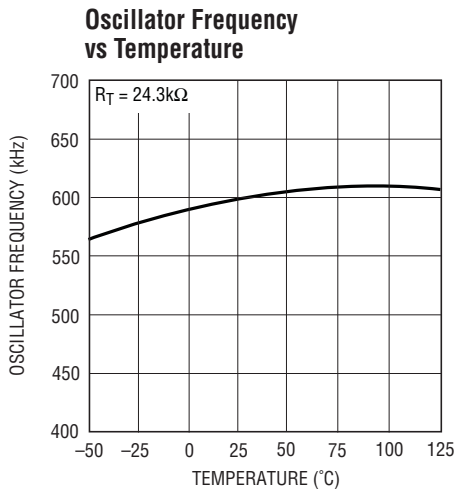

3475 G07

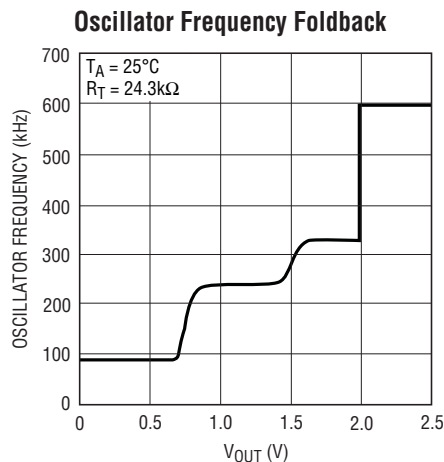

3475 G08

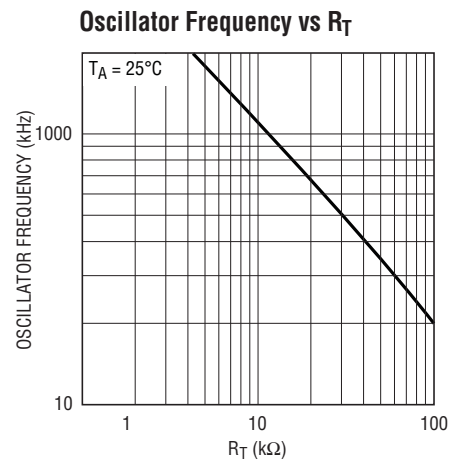

3475 G09

TYPICAL PERFORMANCE CHARACTERISTICS

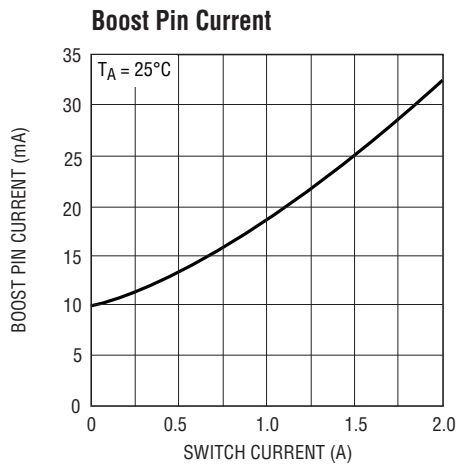

3475 G10

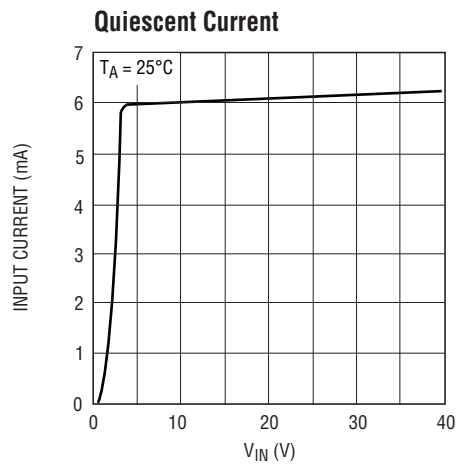

3475 G11

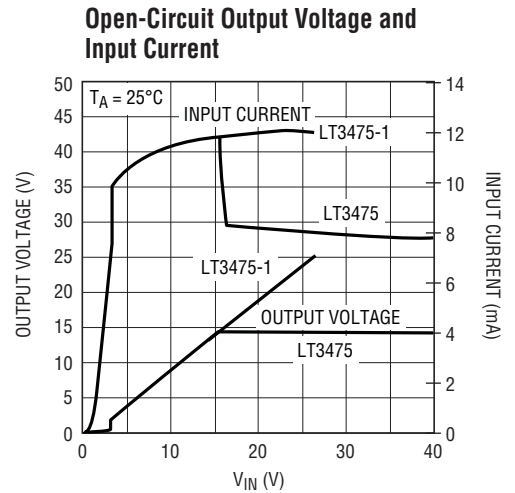

3475 G12

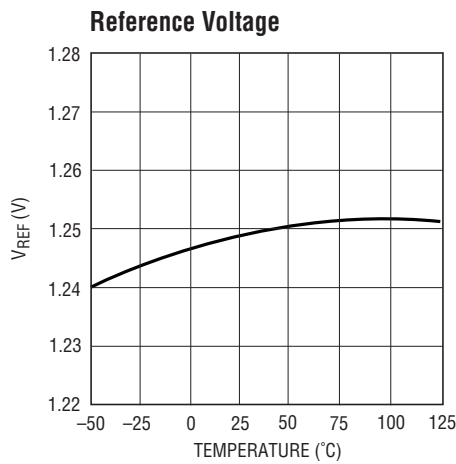

3475 G13

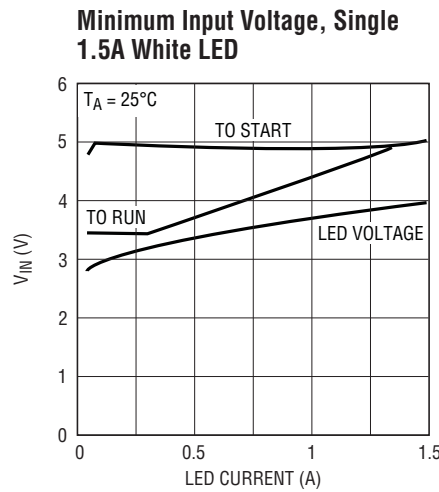

3475 G14

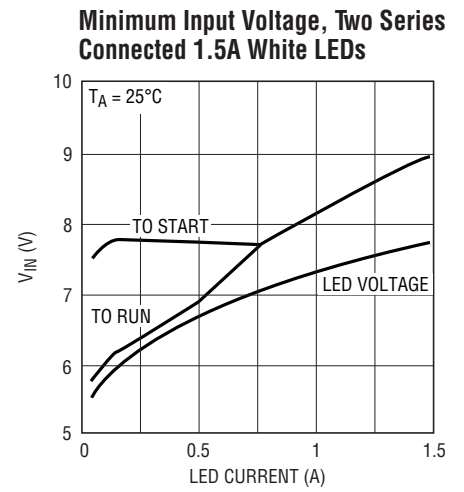

3475 G15

PIN FUNCTIONS

OUT1, OUT2 (Pins 1, 10): The OUT pin is the input to the current sense resistor. Connect this pin to the inductor and the output capacitor.

LED1, LED2 (Pins 2, 9): The LED pin is the output of the current sense resistor. Connect the anode of the LED here.

V_{IN} (Pins 5, 6): The V_{IN} pins supply current to the internal circuitry and to the internal power switches and must be locally bypassed.

SW1, SW2 (Pins 4, 7): The SW pin is the output of the internal power switch. Connect this pin to the inductor, switching diode and boost capacitor.

BOOST1, BOOST2 (Pins 3, 8): The BOOST pin is used to provide a drive voltage, higher than the input voltage, to the internal bipolar NPN power switch.

GND (Pins 15, Exposed Pad Pin 21): Ground. Tie the GND pin and the exposed pad directly to the ground plane. The exposed pad metal of the package provides both electrical contact to ground and good thermal contact to the printed circuit board. The exposed pad must be soldered to the circuit board for proper operation. Use a large ground plane and thermal vias to optimize thermal performance.

PIN FUNCTIONS

R_T (Pin 14): The R_T pin is used to set the internal oscillator frequency. Tie a 24.3k resistor from R_T to GND for a 600kHz switching frequency.

SHDN (Pin 16): The SHDN pin is used to shut down the switching regulator and the internal bias circuits. The 2.6V switching threshold can function as an accurate undervoltage lockout. Pull below 0.3V to shut down the LT3475/LT3475-1. Pull above 2.6V to enable the LT3475/LT3475-1. Tie to V_{IN} if the SHDN function is unused.

REF (Pin 17): The REF pin is the buffered output of the internal reference. Either tie the REF pin to the V_{ADJ} pin for a 1.5A output current, or use a resistor divider to generate a lower voltage at the V_{ADJ} pin. Leave this pin unconnected if unused.

V_{C1}, V_{C2} (Pins 18, 13): The V_C pin is the output of the internal error amp. The voltage on this pin controls the peak switch current. Use this pin to compensate the control loop.

V_{ADJ1}, V_{ADJ2} (Pins 19, 12): The V_{ADJ} pin is the input to the internal voltage-to-current amplifier. Connect the V_{ADJ} pin to the REF pin for a 1.5A output current. For lower output currents, program the V_{ADJ} pin using the following formula: $I_{LED} = 1.5A \cdot V_{ADJ}/1.25V$.

PWM1, PWM2 (Pins 20, 11): The PWM pin controls the connection of the V_C pin to the internal circuitry. When the PWM pin is low, the V_C pin is disconnected from the internal circuitry and draws minimal current. If the PWM feature is unused, leave this pin unconnected.

BLOCK DIAGRAM

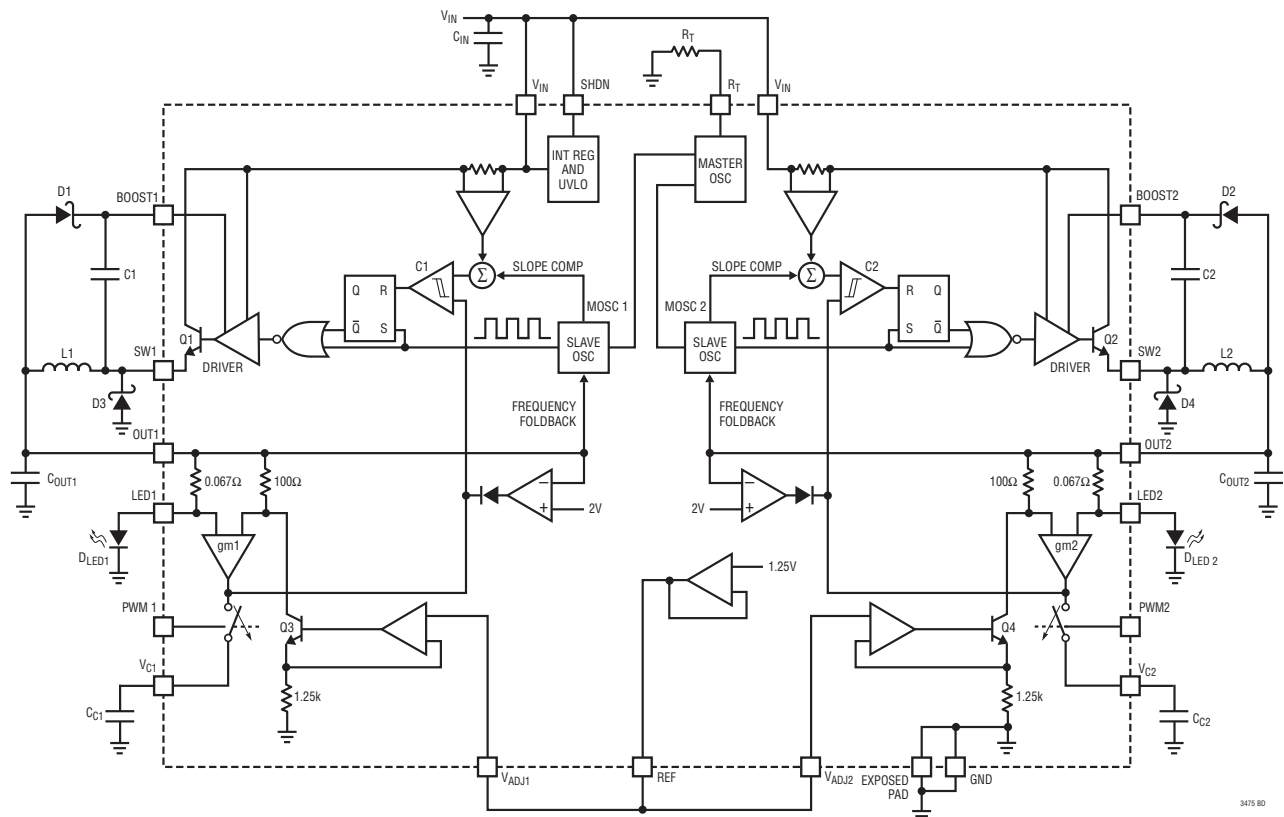

3475 80

OPERATION

The LT3475 is a dual constant frequency, current mode regulator with internal power switches capable of generating constant 1.5A outputs. Operation can be best understood by referring to the Block Diagram.

If the SHDN pin is tied to ground, the LT3475 is shut down and draws minimal current from the input source tied to V_{IN} . If the SHDN pin exceeds 1V, the internal bias circuits turn on, including the internal regulator, reference and oscillator. The switching regulators will only begin to operate when the SHDN pin exceeds 2.6V.

The switcher is a current mode regulator. Instead of directly modulating the duty cycle of the power switch, the feedback loop controls the peak current in the switch during each cycle. Compared to voltage mode control, current mode control improves loop dynamics and provides cycle-by-cycle current limit.

A pulse from the oscillator sets the RS flip-flop and turns on the internal NPN bipolar power switch. Current in the switch and the external inductor begins to increase. When this current exceeds a level determined by the voltage at V_C , current comparator C1 resets the flip-flop, turning off the switch. The current in the inductor flows through the external Schottky diode and begins to decrease. The cycle begins again at the next pulse from the oscillator. In this way, the voltage on the V_C pin controls the current through the inductor to the output. The internal error amplifier regulates the output current by continually adjusting the V_C pin voltage. The threshold for switching on the V_C pin is 0.8V, and an active clamp of 1.8V limits the output current.

The voltage on the V_{ADJ} pin sets the current through the LED pin. The NPN, Q3, pulls a current proportional to the voltage on the V_{ADJ} pin through the 100 Ω resistor. The gm amplifier servos the V_C pin to set the current through the 0.067 Ω resistor and the LED pin. When the voltage drop across the 0.067 Ω resistor is equal to the voltage drop across the 100 Ω resistor, the servo loop is balanced.

Tying the REF pin to the V_{ADJ} pin sets the LED pin current to 1.5A. Tying a resistor divider to the REF pin allows the

programming of LED pin currents of less than 1.5A. LED pin current can also be programmed by tying the V_{ADJ} pin directly to a voltage source.

An LED can be dimmed with pulse width modulation using the PWM pin and an external NFET. If the PWM pin is unconnected or is pulled high, the part operates nominally. If the PWM pin is pulled low, the V_C pin is disconnected from the internal circuitry and draws minimal current from the compensation capacitor. Circuitry drawing current from the OUT pin is also disabled. This way, the V_C pin and the output capacitor store the state of the LED pin current until the PWM is pulled high again. This leads to a highly linear relationship between pulse width and output light, allowing for a large and accurate dimming range.

The R_T pin allows programming of the switching frequency. For applications requiring the smallest external components possible, a fast switching frequency can be used. If low dropout or very high input voltages are required, a slower switching frequency can be programmed.

During startup V_{OUT} will be at a low voltage. The NPN, Q3, can only operate correctly with sufficient voltage of $\approx 1.7V$ at V_{OUT} . A comparator senses V_{OUT} and forces the V_C pin high until V_{OUT} rises above 2V, and Q3 is operating correctly.

The switching regulator performs frequency foldback during overload conditions. An amplifier senses when V_{OUT} is less than 2V and begins decreasing the oscillator frequency down from full frequency to 15% of the nominal frequency when $V_{OUT} = 0V$. The OUT pin is less than 2V during startup, short circuit, and overload conditions. Frequency foldback helps limit switch current under these conditions.

The switch driver operates either from V_{IN} or from the BOOST pin. An external capacitor and Schottky diode are used to generate a voltage at the BOOST pin that is higher than the input supply. This allows the driver to saturate the internal bipolar NPN power switch for efficient operation.

APPLICATIONS INFORMATION

Open Circuit Protection

The LT3475 has internal open-circuit protection. If the LED is absent or is open circuit, the LT3475 clamps the voltage on the LED pin at 14V. The switching regulator then operates at a very low frequency to limit the input current. The LT3475-1 has no internal open circuit protection. With the LT3475-1, be careful not to violate the ABSMAX voltage of the BOOST pin; if $V_{IN} > 25V$, external open circuit protection circuitry (as shown in Figure 1) may be necessary. The output voltage during an open LED condition is shown in the Typical Performance Characteristics section.

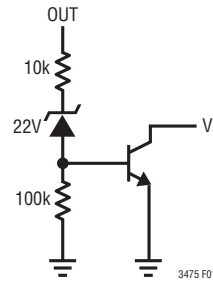

Figure 1. External Overvoltage Protection Circuitry for the LT3475-1

Undervoltage Lockout

Undervoltage lockout (UVLO) is typically used in situations where the input supply is current limited, or has high source resistance. A switching regulator draws constant power from the source, so the source current increases as the source voltage drops. This looks like a negative resistance load to the source and can cause the source to current limit or latch low under low source voltage conditions. UVLO prevents the regulator from operating at source voltages where these problems might occur.

An internal comparator will force the part into shut-down when V_{IN} falls below 3.7V. If an adjustable UVLO threshold is required, the SHDN pin can be used. The threshold voltage of the SHDN pin comparator is 2.6V. An internal resistor pulls 9 μ A to ground from the SHDN pin at the UVLO threshold.

Choose resistors according to the following formula:

$$R2 = \frac{2.6V}{\frac{V_{TH} - 2.6V}{R1} - 9\mu A}$$

V_{TH} = UVLO Threshold

Example: Switching should not start until the input is above 8V.

$V_{TH} = 8V$

$R1 = 100k$

$$R2 = \frac{2.6V}{\frac{8V - 2.6V}{100k} - 9\mu A} = 57.6k$$

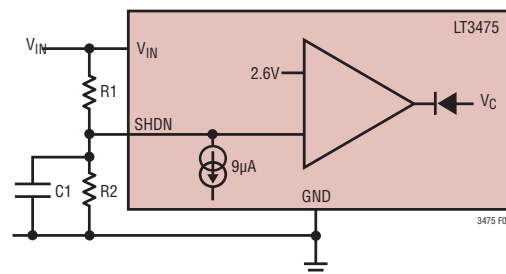

Figure 2. Undervoltage Lockout

Keep the connections from the resistors to the SHDN pin short and make sure the coupling to the SW and BOOST pins is minimized. If high resistance values are used, the SHDN pin should be bypassed with a 1nF capacitor to prevent coupling problems from switching nodes.

Setting the Switching Frequency

The LT3475 uses a constant frequency architecture that can be programmed over a 200kHz to 2MHz range with a single external timing resistor from the R_T pin to ground. A graph for selecting the value of R_T for a given operating frequency is shown in the Typical Applications section.

Table 1. Switching Frequencies

SWITCHING FREQUENCY (MHz)	R_T (k Ω)
2	4.32
1.5	6.81
1.2	9.09
1	11.8
0.8	16.9
0.6	24.3
0.4	40.2
0.3	57.6
0.2	100

3475fb

APPLICATIONS INFORMATION

Table 1 shows suggested R_T selections for a variety of switching frequencies.

Operating Frequency Selection

The choice of operating frequency is determined by several factors. There is a tradeoff between efficiency and component size. A higher switching frequency allows the use of smaller inductors at the cost of increased switching losses and decreased efficiency.

Another consideration is the maximum duty cycle. In certain applications, the converter needs to operate at a high duty cycle in order to work at the lowest input voltage possible. The LT3475 has a fixed oscillator off time and a variable on time. As a result, the maximum duty cycle increases as the switching frequency is decreased.

Input Voltage Range

The minimum operating voltage is determined either by the LT3475's undervoltage lockout of 4V, or by its maximum duty cycle. The duty cycle is the fraction of time that the internal switch is on and is determined by the input and output voltages:

$$DC = \frac{(V_{OUT} + V_F)}{(V_{IN} - V_{SW} + V_F)}$$

where V_F is the forward voltage drop of the catch diode (~0.4V) and V_{SW} is the voltage drop of the internal switch (~0.4V at maximum load). This leads to a minimum input voltage of:

$$V_{IN(MIN)} = \frac{V_{OUT} + V_F}{DC_{MAX}} - V_F + V_{SW}$$

with $DC_{MAX} = 1 - t_{OFF(MIN)} \cdot f$

where $t_{OFF(MIN)}$ is equal to 167ns and f is the switching frequency.

Example: $f = 600\text{kHz}$, $V_{OUT} = 4\text{V}$

$$DC_{MAX} = 1 - 167\text{ns} \cdot 600\text{kHz} = 0.90$$

$$V_{IN(MIN)} = \frac{4\text{V} + 0.4\text{V}}{0.9} - 0.4\text{V} + 0.4\text{V} = 4.9\text{V}$$

The maximum operating voltage is determined by the absolute maximum ratings of the V_{IN} and BOOST pins, and by the minimum duty cycle.

$$V_{IN(MAX)} = \frac{V_{OUT} + V_F}{DC_{MIN}} - V_F + V_{SW}$$

with $DC_{MIN} = t_{ON(MIN)} \cdot f$

where $t_{ON(MIN)}$ is equal to 140ns and f is the switching frequency.

Example: $f = 750\text{kHz}$, $V_{OUT} = 3.4\text{V}$

$$DC_{MIN} = 140\text{ns} \cdot 750\text{kHz} = 0.105$$

$$V_{IN(MAX)} = \frac{3.4\text{V} + 0.4\text{V}}{0.105} - 0.4\text{V} + 0.4\text{V} = 36\text{V}$$

The minimum duty cycle depends on the switching frequency. Running at a lower switching frequency might allow a higher maximum operating voltage. Note that this is a restriction on the operating input voltage; the circuit will tolerate transient inputs up to the Absolute Maximum Ratings of the V_{IN} and BOOST pins. The input voltage should be limited to the V_{IN} operating range (36V) during overload conditions (short circuit or start up).

Minimum On Time

The LT3475 will regulate the output current at input voltages greater than $V_{IN(MAX)}$. For example, an application with an output voltage of 3V and switching frequency of 1.2MHz has a $V_{IN(MAX)}$ of 20V, as shown in Figure 3. Figure 4 shows operation at 35V. Output ripple and peak inductor

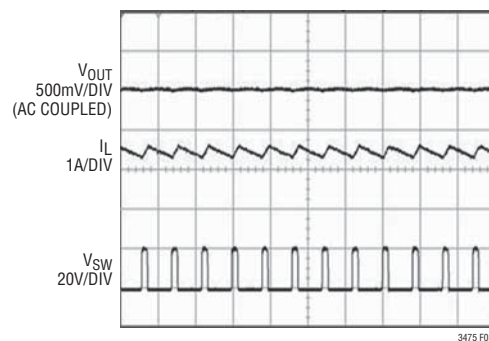

Figure 3. Operation at $V_{IN(MAX)} = 20\text{V}$. $V_{OUT} = 3\text{V}$ and $f_{SW} = 1.2\text{MHz}$

APPLICATIONS INFORMATION

current have significantly increased. Exceeding $V_{IN(MAX)}$ is safe if the external components have adequate ratings to handle the peak conditions and if the peak inductor current does not exceed 3.2A. A saturating inductor may further reduce performance.

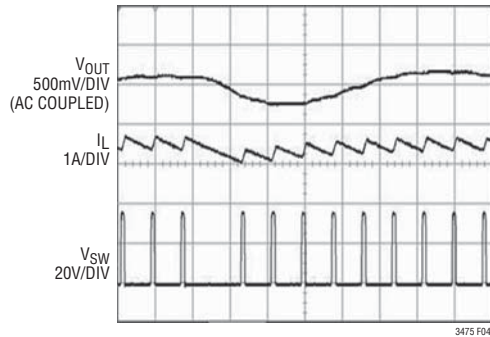

Figure 4. Operation above $V_{IN(MAX)}$. Output Ripple and Peak Inductor Current Increases

Inductor Selection and Maximum Output Current

A good first choice for the inductor value is:

$$L = (V_{OUT} + V_F) \cdot \frac{1.2\text{MHz}}{f}$$

where V_F is the voltage drop of the catch diode ($\sim 0.4V$), f is the switching frequency and L is in μH . With this value the maximum load current will be above 1.6A at all duty cycles. The inductor's RMS current rating must be greater than the maximum load current and its saturation current should be at least 30% higher. For highest efficiency, the series resistance (DCR) should be less than 0.15Ω . Table 2 lists several vendors and types that are suitable. For robust operation at full load and high input voltages ($V_{IN} > 30V$), use an inductor with a saturation current higher than 3.2A.

Table 2. Inductors

PART NUMBER	VALUE (μH)	I_{RMS} (A)	DCR (Ω)	HEIGHT (mm)
Sumida				
CR43-3R3	3.3	1.44	0.086	3.5
CR43-4R7	4.7	1.15	0.109	3.5
CDRH4D16-3R3	3.3	1.10	0.063	1.8
CDRH4D28-3R3	3.3	1.57	0.049	3.0
CDRH4D28-4R7	4.7	1.32	0.072	3.0
CDRH6D26-5R0	5.0	2.20	0.032	2.8
CDRH6D26-5R6	5.6	2.0	0.036	2.8
CDRH5D28-100	10	1.30	0.048	3.0
CDRH5D28-150	15	1.10	0.076	3.0
CDRH73-100	10	1.68	0.072	3.4
CDRH73-150	15	1.33	0.130	3.4
CDRH104R-150	15	3.1	0.050	4.0
Coilcraft				
DO1606T-332	3.3	1.30	0.100	2.0
DO1606T-472	4.7	1.10	0.120	2.0
DO1608C-332	3.3	2.00	0.080	2.9
DO1608C-472	4.7	1.50	0.090	2.9
MOS6020-332	3.3	1.80	0.046	2.0
MOS6020-472	10	1.50	0.050	2.0
DO3316P-103	10	3.9	0.038	5.2
DO3316P-153	15	3.1	0.046	5.2

The optimum inductor for a given application may differ from the one indicated by this simple design guide. A larger value inductor provides a higher maximum load current, and reduces the output voltage ripple. If your load is lower than the maximum load current, then you can relax the value of the inductor and operate with higher ripple current. This allows you to use a physically smaller inductor, or one with a lower DCR resulting in higher efficiency. In addition, low inductance may result in discontinuous mode operation, which further reduces maximum load current. For details of maximum output current and discontinuous mode operation, see Linear Technology's Application Note 44. Finally, for duty cycles greater than 50% ($V_{OUT}/V_{IN} > 0.5$), a minimum inductance is required to avoid sub-harmonic oscillations:

$$L_{MIN} = (V_{OUT} + V_F) \cdot \frac{800\text{kHz}}{f}$$

APPLICATIONS INFORMATION

The current in the inductor is a triangle wave with an average value equal to the load current. The peak switch current is equal to the output current plus half the peak-to-peak inductor ripple current. The LT3475 limits its switch current in order to protect itself and the system from overload faults. Therefore, the maximum output current that the LT3475 will deliver depends on the switch current limit, the inductor value, and the input and output voltages.

When the switch is off, the potential across the inductor is the output voltage plus the catch diode drop. This gives the peak-to-peak ripple current in the inductor

$$\Delta I_L = \frac{(1-DC)(V_{OUT} + V_F)}{L \cdot f}$$

where f is the switching frequency of the LT3475 and L is the value of the inductor. The peak inductor and switch current is

$$I_{SW(PK)} = I_{L(PK)} = I_{OUT} + \frac{\Delta I_L}{2}$$

To maintain output regulation, this peak current must be less than the LT3475's switch current limit I_{LIM} . I_{LIM} is at least 2.3A at low duty cycles and decreases linearly to 1.8A at $DC = 0.9$. The maximum output current is a function of the chosen inductor value:

$$\begin{aligned} I_{OUT(MAX)} &= I_{LIM} - \frac{\Delta I_L}{2} \\ &= 2.3A \cdot (1 - 0.25 \cdot DC) - \frac{\Delta I_L}{2} \end{aligned}$$

Choosing an inductor value so that the ripple current is small will allow a maximum output current near the switch current limit.

One approach to choosing the inductor is to start with the simple rule given above, look at the available inductors, and choose one to meet cost or space goals. Then use these equations to check that the LT3475 will be able to deliver the required output current. Note again that these equations assume that the inductor current is continuous. Discontinuous operation occurs when I_{OUT} is less than $\Delta I_L/2$.

Input Capacitor Selection

Bypass the input of the LT3475 circuit with a 4.7 μ F or higher ceramic capacitor of X7R or X5R type. A lower value or a less expensive Y5V type will work if there is additional bypassing provided by bulk electrolytic capacitors or if the input source impedance is low. The following paragraphs describe the input capacitor considerations in more detail.

Step-down regulators draw current from the input supply in pulses with very fast rise and fall times. The input capacitor is required to reduce the resulting voltage ripple at the LT3475 input and to force this switching current into a tight local loop, minimizing EMI. The input capacitor must have low impedance at the switching frequency to do this effectively, and it must have an adequate ripple current rating. With two switchers operating at the same frequency but with different phases and duty cycles, calculating the input capacitor RMS current is not simple. However, a conservative value is the RMS input current for the channel that is delivering most power ($V_{OUT} \cdot I_{OUT}$):

$$C_{INRMS} = I_{OUT} \cdot \frac{\sqrt{V_{OUT}(V_{IN} - V_{OUT})}}{V_{IN}} < \frac{I_{OUT}}{2}$$

and is largest when $V_{IN} = 2V_{OUT}$ (50% duty cycle). As the second, lower power channel draws input current, the input capacitor's RMS current actually decreases as the out-of-phase current cancels the current drawn by the higher power channel. Considering that the maximum load current from a single channel is ~1.5A, RMS ripple current will always be less than 0.75A.

The high frequency of the LT3475 reduces the energy storage requirements of the input capacitor, so that the capacitance required is less than 10 μ F. The combination of small size and low impedance (low equivalent series resistance or ESR) of ceramic capacitors makes them the preferred choice. The low ESR results in very low voltage ripple. Ceramic capacitors can handle larger magnitudes of ripple current than other capacitor types of the same value. Use X5R and X7R types.

APPLICATIONS INFORMATION

An alternative to a high value ceramic capacitor is a lower value ceramic along with a larger electrolytic capacitor. The electrolytic capacitor likely needs to be greater than 10 μ F in order to meet the ESR and ripple current requirements. The input capacitor is likely to see high surge currents when the input source is applied. Tantalum capacitors can fail due to an over-surge of current. Only use tantalum capacitors with the appropriate surge current rating. The manufacturer may also recommend operation below the rated voltage of the capacitor.

A final caution is in order regarding the use of ceramic capacitors at the input. A ceramic input capacitor can combine with stray inductance to form a resonant tank circuit. If power is applied quickly (for example by plugging the circuit into a live power source) this tank can ring, doubling the input voltage and damaging the LT3475. The solution is to either clamp the input voltage or dampen the tank circuit by adding a lossy capacitor in parallel with the ceramic capacitor. For details, see Application Note 88.

Output Capacitor Selection

For most LEDs, a 2.2 μ F, 6.3V ceramic capacitor (X5R or X7R) at the output results in very low output voltage ripple and good transient response. Other types and values will also work. The following discusses tradeoffs in output ripple and transient performance.

The output capacitor filters the inductor current to generate an output with low voltage ripple. It also stores energy in order to satisfy transient loads and stabilizes the LT3475's control loop. Because the LT3475 operates at a high frequency, minimal output capacitance is necessary. In addition, the control loop operates well with or without the presence of output capacitor series resistance (ESR). Ceramic capacitors, which achieve very low output ripple and small circuit size, are therefore an option.

You can estimate output ripple with the following equation:

$$V_{\text{RIPPLE}} = \Delta I_L / (8 \cdot f \cdot C_{\text{OUT}}) \text{ for ceramic capacitors}$$

where ΔI_L is the peak-to-peak ripple current in the inductor. The RMS content of this ripple is very low so the

RMS current rating of the output capacitor is usually not of concern. It can be estimated with the formula:

$$I_{C(\text{RMS})} = \Delta I_L / \sqrt{12}$$

The low ESR and small size of ceramic capacitors make them the preferred type for LT3475 applications. Not all ceramic capacitors are the same, however. Many of the higher value capacitors use poor dielectrics with high temperature and voltage coefficients. In particular Y5V and Z5U types lose a large fraction of their capacitance with applied voltage and at temperature extremes. Because loop stability and transient response depend on the value of C_{OUT} , this loss may be unacceptable. Use X7R and X5R types. Table 3 lists several capacitor vendors.

Table 3. Low ESR Surface Mount Capacitors.

VENDOR	TYPE	SERIES
Taiyo-Yuden	Ceramic	X5R, X7R
AVX	Ceramic	X5R, X7R
TDK	Ceramic	X5R, X7R

Diode Selection

The catch diode (D3 from the Block Diagram) conducts current only during switch off time. Average forward current in normal operation can be calculated from:

$$I_{D(\text{AVG})} = I_{\text{OUT}} (V_{\text{IN}} - V_{\text{OUT}}) / V_{\text{IN}}$$

The only reason to consider a diode with a larger current rating than necessary for nominal operation is for the worst-case condition of shorted output. The diode current will then increase to one half the typical peak switch current limit.

Peak reverse voltage is equal to the regulator input voltage. Use a diode with a reverse voltage rating greater than the input voltage. Table 4 lists several Schottky diodes and their manufacturers.

Diode reverse leakage can discharge the output capacitor during LED off times while PWM dimming. If operating at high ambient temperatures, use a low leakage Schottky for the widest PWM dimming range.

APPLICATIONS INFORMATION

Table 4. Schottky Diodes

	V _R (V)	I _{AVE} (A) (A)	V _F at 1A (mV)	V _F at 2A (mV)
On Semiconductor				
MBR0540	40	0.5	620	
MBRM120E	20	1	530	
MBRM140	40	1	550	
Diodes Inc				
B120	20	1	500	
B130	30	1	500	
B140HB	40	1	530	
DFLS140	40	1.1	510	
B240	40	2		500
International Rectifier				
10BQ030	30	1	420	

BOOST Pin Considerations

The capacitor and diode tied to the BOOST pin generate a voltage that is higher than the input voltage. In most cases, a 0.22µF capacitor and fast switching diode (such as the CMDSH-3 or MMSD914LT1) will work well. Figure 5 shows three ways to arrange the boost circuit. The BOOST pin must be more than 2.5V above the SW

pin for full efficiency. For outputs of 3.3V and higher, the standard circuit (Figure 5a) is best. For outputs between 2.8V and 3.3V, use a small Schottky diode (such as the BAT-54). For lower output voltages, the boost diode can be tied to the input (Figure 5b). The circuit in Figure 5a is more efficient because the BOOST pin current comes from a lower voltage source. The anode of the boost diode can be tied to another source that is at least 3V. For example, if you are generating a 3.3V output, and the 3.3V output is on whenever the LED is on, the BOOST pin can be connected to the 3.3V output. For LT3475-1 applications with higher output voltages, an additional Zener diode may be necessary (Figure 5d) to maintain pin voltage below the absolute maximum. In any case, be sure that the maximum voltage at the BOOST pin is both less than 60V and the voltage difference between the BOOST and SW pins is less than 30V.

The minimum operating voltage of an LT3475 application is limited by the undervoltage lockout (~3.7V) and by the maximum duty cycle. The boost circuit also limits the minimum input voltage for proper start up. If the input voltage ramps slowly, or the LT3475 turns on when the output is already in regulation, the boost capacitor may not be fully charged. Because the boost capacitor charges

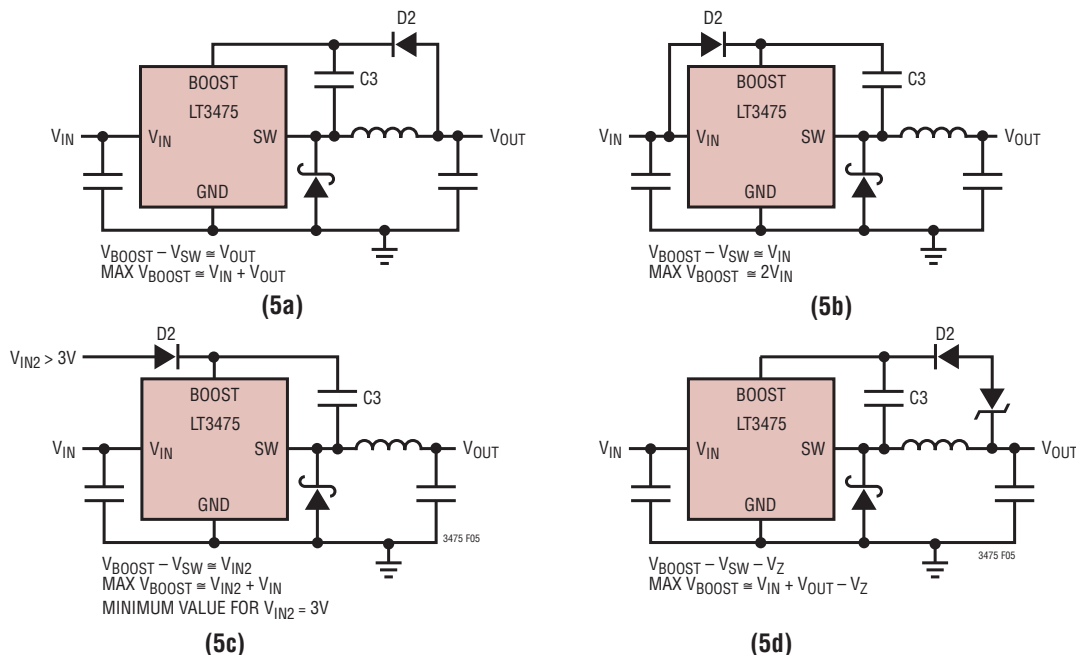

Figure 5. Generating the Boost Voltage

APPLICATIONS INFORMATION

with the energy stored in the inductor, the circuit will rely on some minimum load current to get the boost circuit running properly. This minimum load will depend on input and output voltages, and on the arrangement of the boost circuit. The minimum load current generally goes to zero once the circuit has started. The typical performance characteristics section shows a plot of minimum load to start and to run as a function of input voltage. Even without an output load current, in many cases the discharged output capacitor will present a load to the switcher that will allow it to start. The plots show the worst case, where V_{IN} is ramping very slowly.

Programming LED Current

The LED current can be set by adjusting the voltage on the V_{ADJ} pin. For a 1.5A LED current, either tie V_{ADJ} to REF or to a 1.25V source. For lower output currents, program the V_{ADJ} using the following formula: $I_{LED} = 1.5A \cdot V_{ADJ}/1.25V$. Voltages less than 1.25V can be generated with a voltage divider from the REF pin, as shown in Figure 6. In order to have accurate LED current, precision resistors are preferred (1% or better is recommended). Note that the V_{ADJ} pin sources a small amount of bias current, so use the following formula to choose resistors:

$$R2 = \frac{V_{ADJ}}{\frac{1.25V - V_{ADJ}}{R1} + 50nA}$$

To minimize the error from variations in V_{ADJ} pin current, use resistors with a parallel resistance of less than 4k. Use resistor strings with a high enough series resistance so as not to exceed the 500 μ A current compliance of the REF pin.

Dimming Control

There are several different types of dimming control circuits. One dimming control circuit (Figure 7) changes

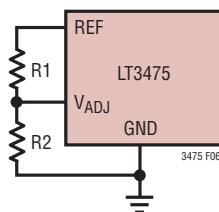

Figure 6. Setting V_{ADJ} with a Resistor Divider

the voltage on the V_{ADJ} pin by tying a low on resistance FET to the resistor divider string. This allows the selection of two different LED currents. For reliable operation program an LED current of no less than 50mA. The maximum current dimming ratio (I_{RATIO}) can be calculated from the maximum LED current (I_{MAX}) and the minimum LED current (I_{MIN}) as follows:

$$I_{MAX}/I_{MIN} = I_{RATIO}$$

Another dimming control circuit (Figure 8) uses the PWM pin and an external NFET tied to the cathode of the LED. An external PWM signal is applied to the PWM pin and the gate of the NFET (For PWM dimming ratios of 20 to 1 or less, the NFET can be omitted). The average LED current is proportional to the duty cycle of the PWM signal. When the PWM signal goes low, the NFET turns off, turning off the LED and leaving the output capacitor charged. The PWM pin is pulled low as well, which disconnects the V_C pin, storing the voltage in the capacitor tied there. Use the C-RC string shown in Figure 8 and Figure 9 tied to the V_C pin for proper operation during startup. When the PWM pin goes high again, the LED current returns rapidly to its previous on state since the compensation and output capacitors are at the correct voltage. This fast settling time allows the

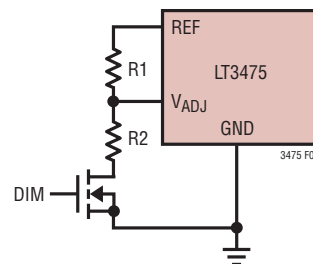

Figure 7. Dimming with a MOSFET and Resistor Divider

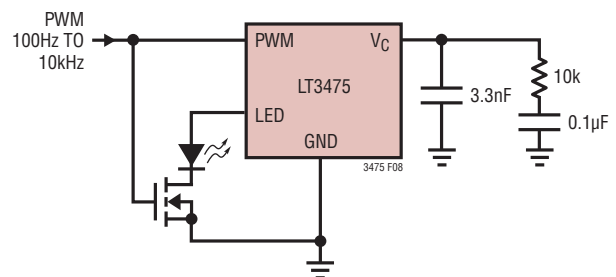

Figure 8. Dimming Using PWM Signal

APPLICATIONS INFORMATION

LT3475 to maintain diode current regulation with PWM pulse widths as short as 7.5 switching cycles ($12.5\mu\text{s}$ for $f_{\text{SW}} = 600\text{kHz}$). Maximum PWM period is determined by the system and is unlikely to be longer than 12ms. Using PWM periods shorter than $100\mu\text{s}$ is not recommended. The maximum PWM dimming ratio ($\text{PWM}_{\text{RATIO}}$) can be calculated from the maximum PWM period (t_{MAX}) and minimum PWM pulse width (t_{MIN}) as follows:

$$t_{\text{MAX}}/t_{\text{MIN}} = \text{PWM}_{\text{RATIO}}$$

Total dimming ratio ($\text{DIM}_{\text{RATIO}}$) is the product of the PWM dimming ratio and the current dimming ratio.

Example:

$$I_{\text{MAX}} = 1\text{A}, I_{\text{MIN}} = 0.1\text{A}, t_{\text{MAX}} = 9.9\text{ms}$$

$$t_{\text{MIN}} = 3.3\mu\text{s} (f_{\text{SW}} = 1.4\text{MHz})$$

$$I_{\text{RATIO}} = 1\text{A}/0.1\text{A} = 10:1$$

$$\text{PWM}_{\text{RATIO}} = 9.9\text{ms}/3.3\mu\text{s} = 3000:1$$

$$\text{DIM}_{\text{RATIO}} = 10 \cdot 3000 = 30000:1$$

To achieve the maximum PWM dimming ratio, use the circuit shown in Figure 9. This allows PWM pulse widths as short as 4.5 switching cycles ($7.5\mu\text{s}$ for $f_{\text{SW}} = 600\text{kHz}$). Note that if you use the circuit in Figure 9, the rising edge of the two PWM signals must align within 100ns.

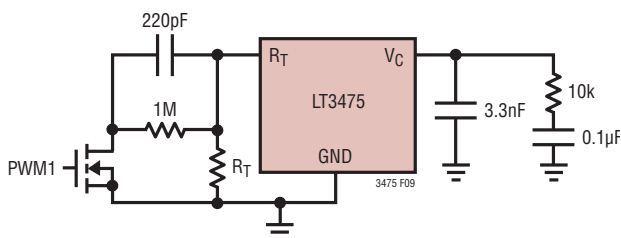

Figure 9. Extending the PWM Dimming Range

Layout Hints

As with all switching regulators, careful attention must be paid to the PCB layout and component placement. To maximize efficiency, switch rise and fall times are made as short as possible. To prevent electromagnetic interference (EMI) problems, proper layout of the high frequency switching path is essential. The voltage signal of the SW and BOOST pins have sharp rise and fall edges. Minimize the area of all traces connected to the BOOST and SW pins and always use a ground plane under the switching regulator to minimize interplane coupling. In addition, the ground connection for frequency setting resistor R_T and capacitors at V_{C1} , V_{C2} pins (refer to the Block Diagram) should be tied directly to the GND pin and not shared with the power ground path, ensuring a clean, noise-free connection.

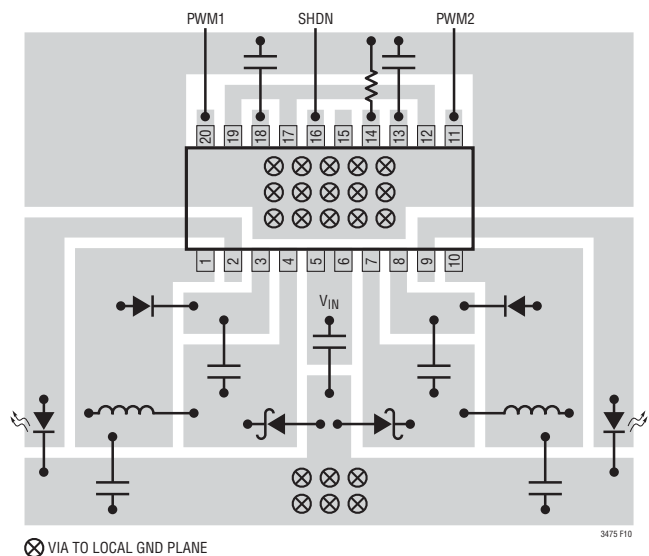
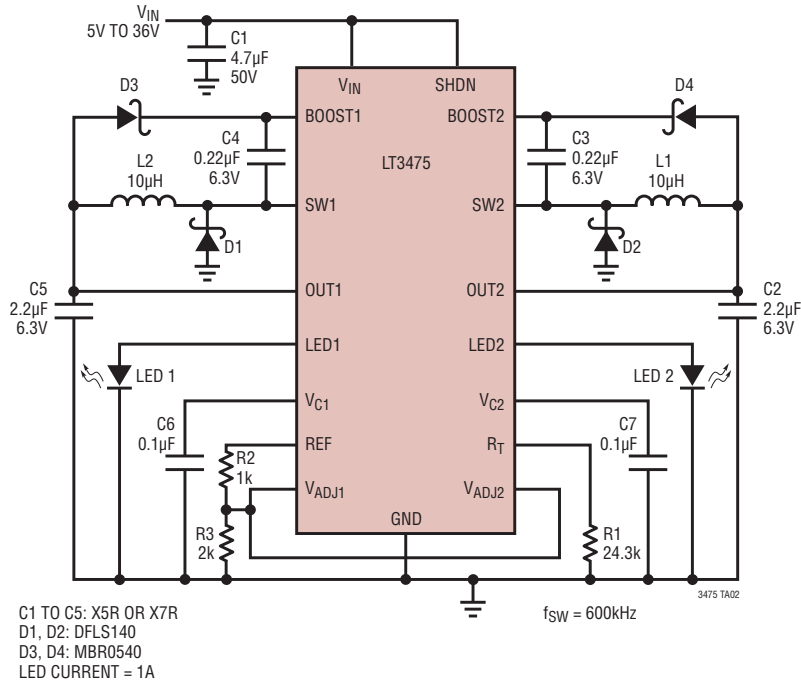

Figure 10. Recommended Component Placement

TYPICAL APPLICATIONS

Dual Step-Down 1A LED Driver



Dual Step-Down 1.5A LED Driver with 1200 : 1 True Color PWM Dimming

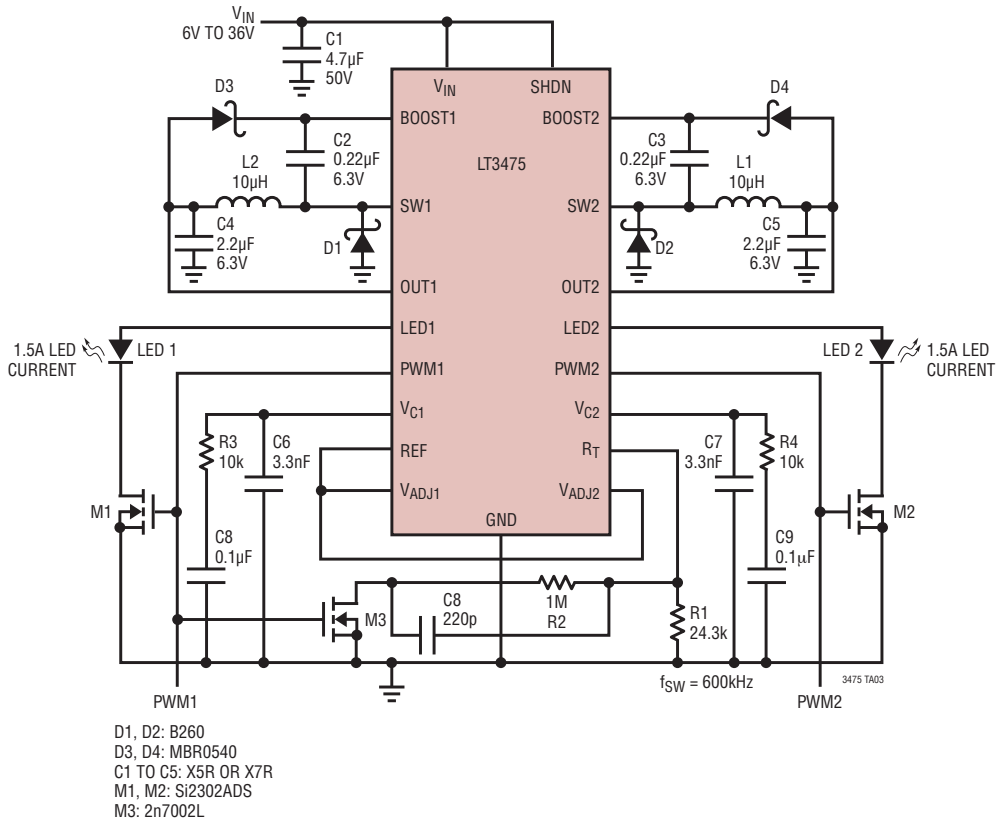

TYPICAL APPLICATIONS

Step-Down 3A LED Driver

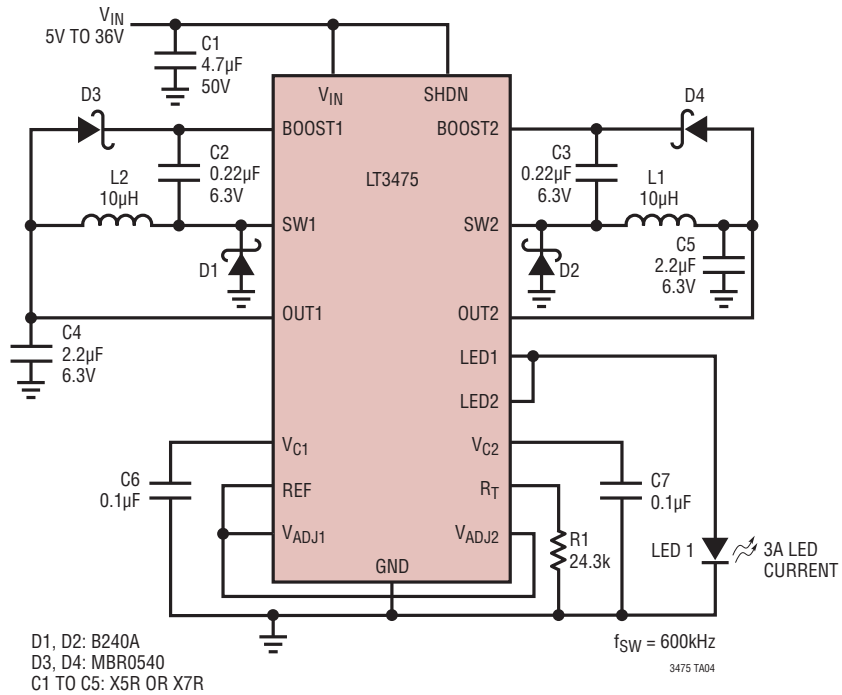

Dual Step-Down LED Driver with Series Connected LEDs

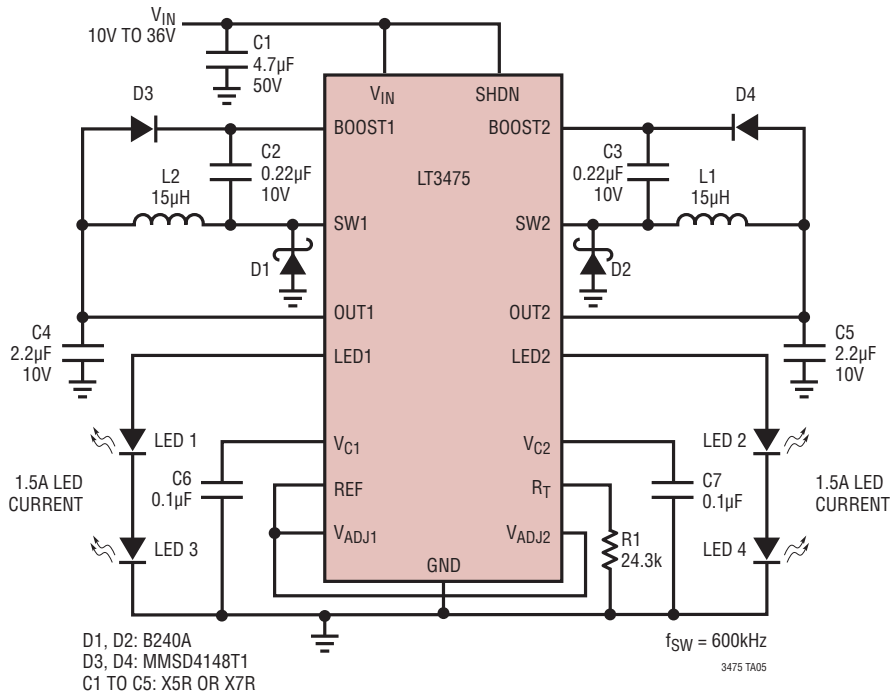

TYPICAL APPLICATIONS

Dual Step-Down 1.5A Red LED Driver

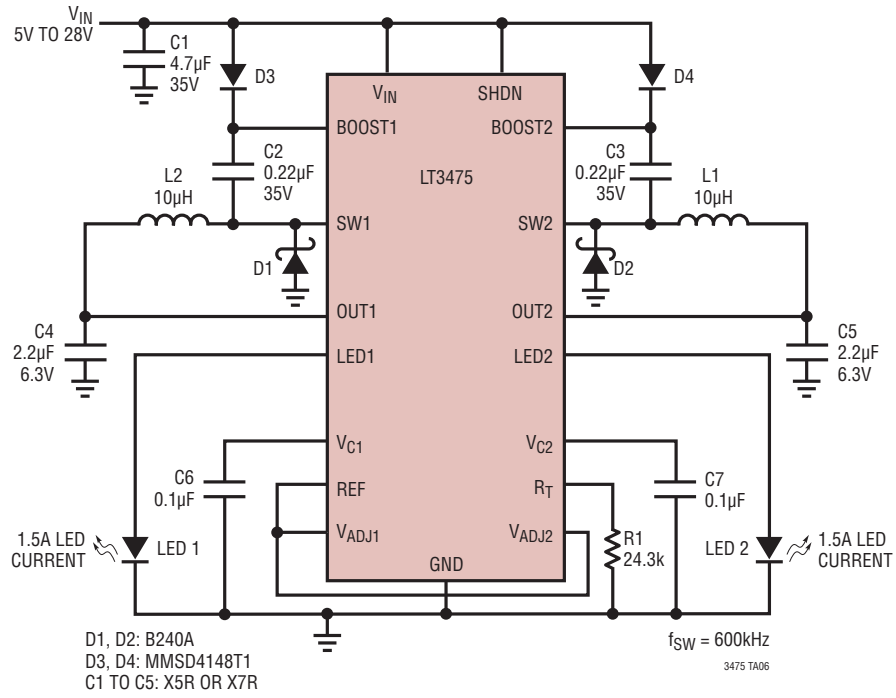

PACKAGE DESCRIPTION

**FE Package
20-Lead Plastic TSSOP (4.4mm)
(Reference LTC DWG # 05-08-1663)
Exposed Pad Variation CB**

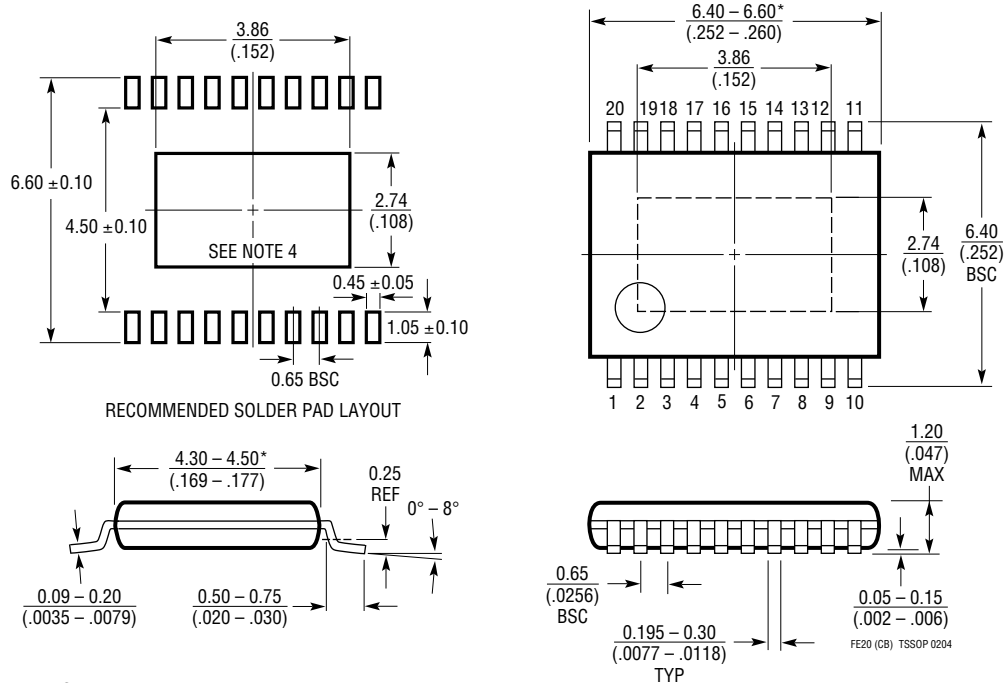

- NOTE:
1. CONTROLLING DIMENSION: MILLIMETERS
 2. DIMENSIONS ARE IN $\frac{\text{MILLIMETERS}}{\text{INCHES}}$
 3. DRAWING NOT TO SCALE
 4. RECOMMENDED MINIMUM PCB METAL SIZE FOR EXPOSED PAD ATTACHMENT
- *DIMENSIONS DO NOT INCLUDE MOLD FLASH. MOLD FLASH SHALL NOT EXCEED 0.150mm (.006") PER SIDE