

500mA Wide Input Voltage Range Step-Down LED Driver with 10:1 Dimming

FEATURES

- **Wide Input Voltage Range**
Operation from 3.6V to 36V
- **Resistor Adjustable 400kHz–2.2MHz Switching Frequency**
- **Shorted and Open LED Protected**
- **Internal Switch Current Sense Resistor**
- **External Resistor Programs LED Current, Pin Selects 10:1 Ratio**
- 50mA/500mA LED Current Settings
- Catch Diode Current Sense to Prevent Runaway at High V_{IN}
- Small Thermally Enhanced 10-Lead DFN (2mm × 3mm) and MSOP-10 Packages

APPLICATIONS

- Automotive Signal Lighting
- Industrial Lighting
- Constant-Current, Constant Voltage Supplies

DESCRIPTION

The LT[®]3592 is a fixed frequency step-down DC/DC converter designed to operate as a constant-current source. An external sense resistor monitors the output current allowing accurate current regulation, ideal for driving high current LEDs. The output current can be dimmed by a factor of 10 using an external signal for nighttime brake lights.

The high switching frequency offers several advantages by permitting the use of a small inductor and small ceramic capacitors. Small components combined with the LT3592's 10-pin DFN leadless surface mount package save space and cost versus alternative solutions. The constant switching frequency combined with low-impedance ceramic capacitors result in low, predictable output ripple.

A wide input voltage range of 3.6V to 36V makes the LT3592 useful in a variety of applications. Current mode PWM architecture provides fast transient response and cycle-by-cycle current limiting. Thermal shutdown provides additional protection.

LT, LT, LTC and LTM are registered trademarks of Linear Technology Corporation. All other trademarks are the property of their respective owners.

TYPICAL APPLICATION

50/500mA Two Series Red LED Driver

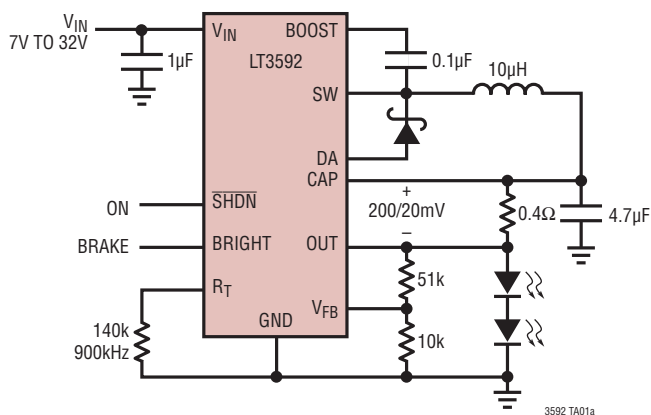

Efficiency for 2 Red LEDs, L = 10µH, 900kHz

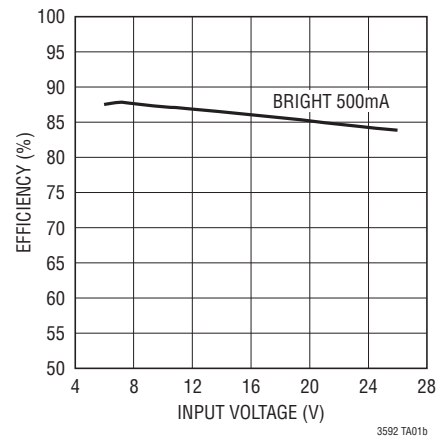

ABSOLUTE MAXIMUM RATINGS (Note 1)

V_{IN} , BRIGHT Voltages	-0.3V to 36V	\overline{SHDN} Voltage	V_{IN}
BOOST Voltage	60V	DA Pin Current (Average).....	-1.2A (sourcing)
BOOST above SW pin	30V	Operating Temperature Range (Notes 2, 3)	
CAP, OUT Voltages ($OUT \leq CAP$)	30V	LT3592E.....	-40°C to 125°C
V_{FB} Voltage	4V	LT3592I.....	-40°C to 125°C
R_T Voltage.....	6V	Storage Temperature Range.....	-65°C to 150°C

PIN CONFIGURATION

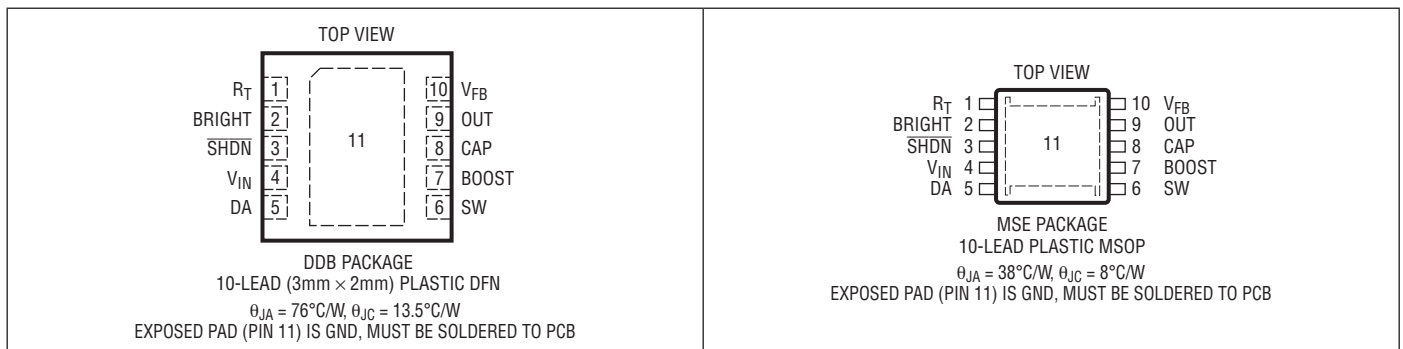

ORDER INFORMATION

LEAD FREE FINISH	TAPE AND REEL	PART MARKING*	PACKAGE DESCRIPTION	TEMPERATURE RANGE
LT3592EDDB#PBF	LT3592EDDB#TRPBF	LDCQ	10-Lead (3mm × 2mm) Plastic DFN	-40°C to 125°C
LT3592IDDB#PBF	LT3592IDDB#TRPBF	LDCQ	10-Lead (3mm × 2mm) Plastic DFN	-40°C to 125°C
LT3592EMSE#PBF	LT3592EMSE#TRPBF	LTDCR	10-Lead Plastic MSOP	-40°C to 125°C
LT3592IMSE#PBF	LT3592IMSE#TRPBF	LTDCR	10-Lead Plastic MSOP	-40°C to 125°C
LEAD BASED FINISH	TAPE AND REEL	PART MARKING	PACKAGE DESCRIPTION	TEMPERATURE RANGE
LT3592EDDB	LT3592EDDB#TR	LDCQ	10-Lead (3mm × 2mm) Plastic DFN	-40°C to 125°C
LT3592IDDB	LT3592IDDB#TR	LDCQ	10-Lead (3mm × 2mm) Plastic DFN	-40°C to 125°C
LT3592EMSE	LT3592EMSE#TR	LTDCR	10-Lead Plastic MSOP	-40°C to 125°C
LT3592IMSE	LT3592IMSE#TR	LTDCR	10-Lead Plastic MSOP	-40°C to 125°C

Consult LTC Marketing for parts specified with wider operating temperature ranges. *The temperature grade is identified by a label on the shipping container.

For more information on lead free part marking, go to: <http://www.linear.com/leadfree/>

For more information on tape and reel specifications, go to: <http://www.linear.com/tapeandreel/>

ELECTRICAL CHARACTERISTICS The ● denotes the specifications which apply over the full operating temperature range, otherwise specifications are at $T_A = 25^\circ\text{C}$. $V_{IN} = 12\text{V}$, $V_{BOOST} = 16\text{V}$, $V_{OUT} = 4\text{V}$ unless otherwise noted. (Note 2)

PARAMETER	CONDITIONS		MIN	TYP	MAX	UNITS
Minimum Input Voltage		●		3.25	3.6	V
Input Quiescent Current in Shutdown	Not Switching $V_{SHDN} = 0.3\text{V}$			2 0.1	3 2	mA μA
CAP to OUT Voltage	0.4 Ω CAP to OUT BRIGHT = 1.4V BRIGHT = 0.3V	● ●	190 18	200 20	210 22	mV mV
DA Pin Current to Stop OSC			-0.8	-1	-1.2	A
Switching Frequency	$R_T = 357\text{k}$ $R_T = 140\text{k}$ $R_T = 48.7\text{k}$		350 800 1.9	400 900 2.2	450 1000 2.5	kHz kHz MHz
Maximum Duty Cycle	$R_T = 140\text{k}$		90	94		%
SHDN Input High Voltage			2.3			V
SHDN Input Low Voltage					0.3	V
BRIGHT Input High Voltage			1.4			V
BRIGHT Input Low Voltage					0.3	V
Switch Current Limit (Note 4)		●	0.85	1.25	1.5	A
Switch V_{CESAT}	$I_{SW} = 500\text{mA}$			300		mV
Boost Pin Current	$I_{SW} = 500\text{mA}$			20	30	mA
Switch Leakage Current				1	10	μA
Minimum Boost Voltage ($V_{BOOST} - V_{IN}$)	$V_{OUT} = 4\text{V}$			1.8	2.5	V
Boost Diode Forward Voltage	$I_{DIO} = 50\text{mA}$			800		mV
V_{FB} Voltage	OUT = CAP = 4V, Bright = 12V	●	1.185	1.21	1.235	V
V_{FB} Input Leakage Current	$V_{FB} = 1.21\text{V}$	●	-250		250	nA

Note 1: Stresses beyond those listed under Absolute Maximum Ratings may cause permanent damage to the device. Exposure to any Absolute Maximum Rating condition for extended periods may affect device reliability and lifetime.

Note 2: The LT3592E is guaranteed to meet performance specifications from 0°C to 125°C junction temperature. Specifications over the -40°C to 125°C operating junction temperature range are assured by design, characterization and correlation with statistical process controls. The LT3592I is guaranteed over the full -40°C to 125°C operating junction temperature range. The operating lifetime is derated at junction temperatures greater than 125°C .

Note 3: This IC includes overtemperature protection that is intended to protect the device during momentary overload conditions. Junction temperature will exceed the maximum operating junction temperature when overtemperature protection is active. Continuous operation above the specified maximum operating junction temperature may result in device degradation or failure.

Note 4: Switch Current Measurements are performed when the outputs are not switching. Slope compensation reduces current limit at higher duty cycles.

TYPICAL PERFORMANCE CHARACTERISTICS ($T_A = 25^\circ\text{C}$, unless otherwise noted)

**Efficiency (2 Red LEDs,
L = 10 μH , 900kHz)**

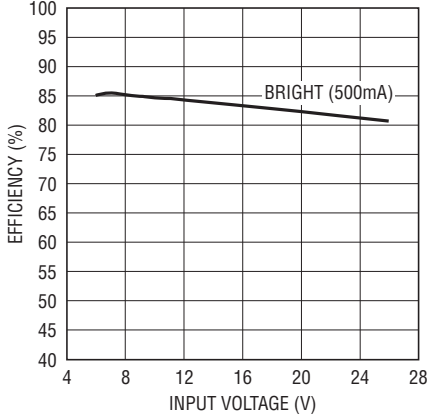

3592 G01

**Efficiency (1 Red LED,
L = 6.8 μH , 900kHz)**

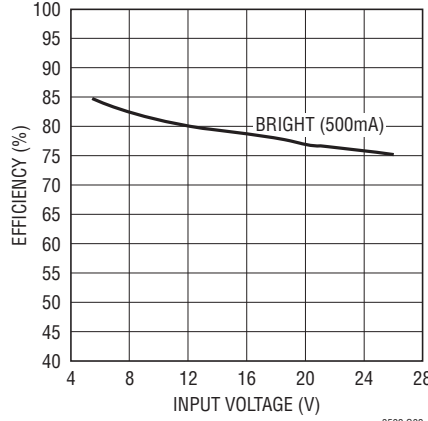

3592 G02

**Efficiency (2 Red LEDs,
L = 22 μH , 400kHz)**

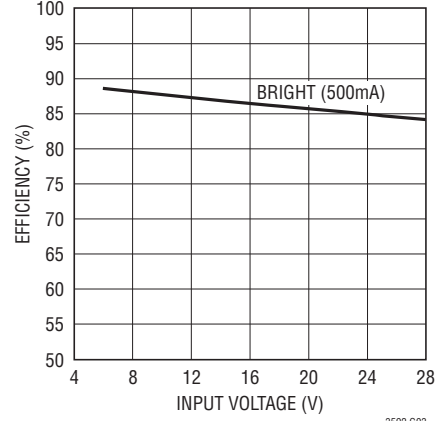

3592 G03

**Efficiency (2 Red LEDs,
L = 4.7 μH , 2.2MHz)**

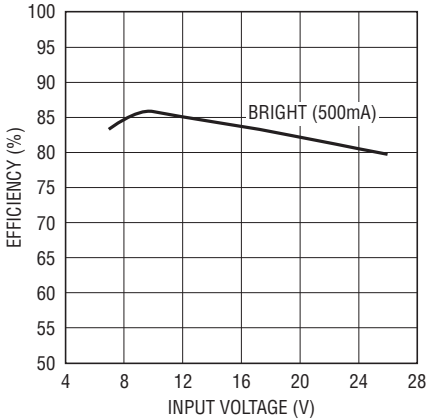

3592 G04

**Minimum V_{IN} for 500mA Output
Current vs V_{OUT} , L = 22 μH ,
f = 400kHz (LED Loads)**

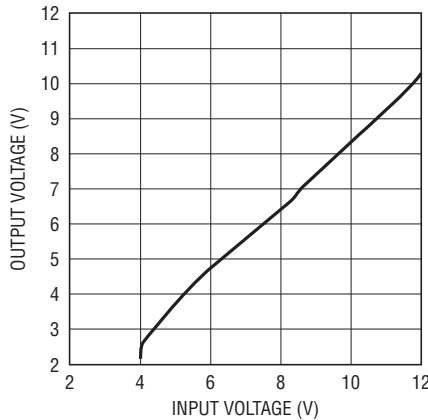

3592 G05

**Minimum V_{IN} for 500mA Output
Current vs V_{OUT} , L = 6.8 μH ,
f = 900kHz (LED Loads)**

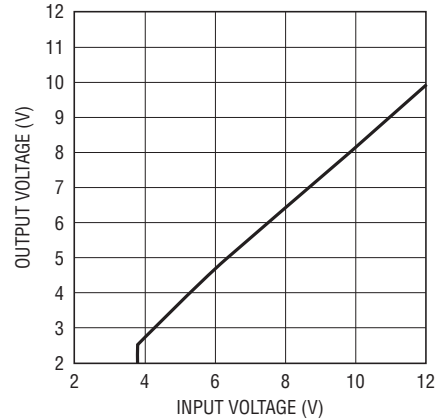

3592 G06

**Minimum V_{IN} for 500mA Output
Current vs V_{OUT} , L = 4.7 μH ,
f = 2.2MHz (LED Loads)**

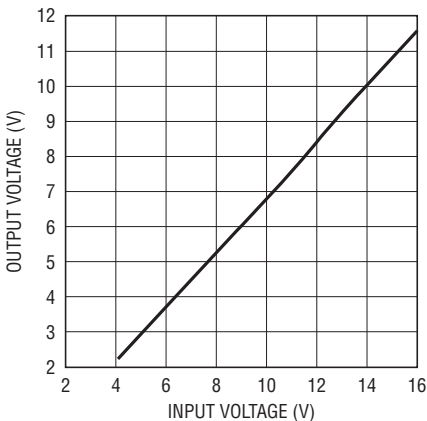

3592 G07

**Switch Voltage Drop
vs Switch Current**

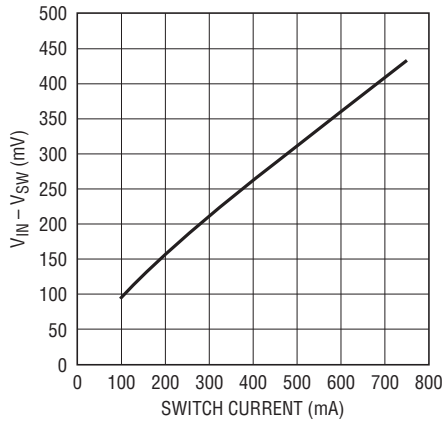

3592 G08

**Switch Voltage Drop at 500mA
vs Temperature**

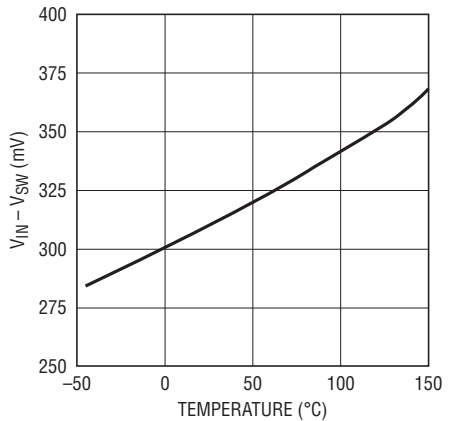

3592 G09

TYPICAL PERFORMANCE CHARACTERISTICS ($T_A = 25^\circ\text{C}$, unless otherwise noted)

Undervoltage Lockout vs Temperature

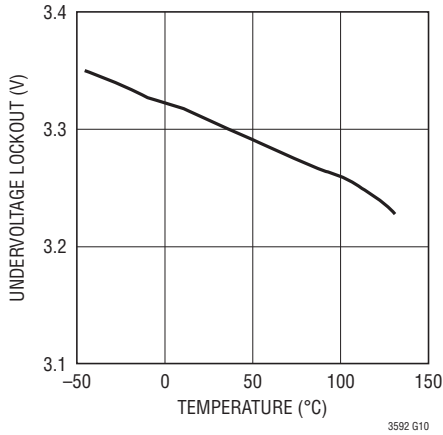

Switching Frequency vs Temperature

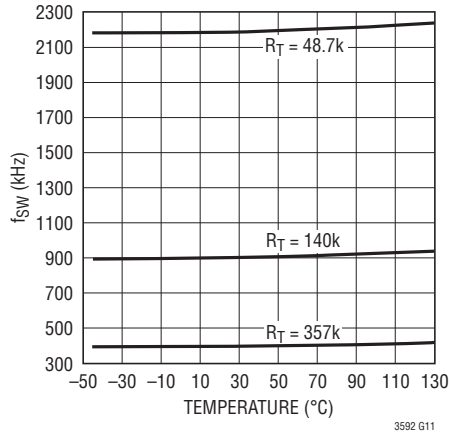

Current Limit During Soft Start

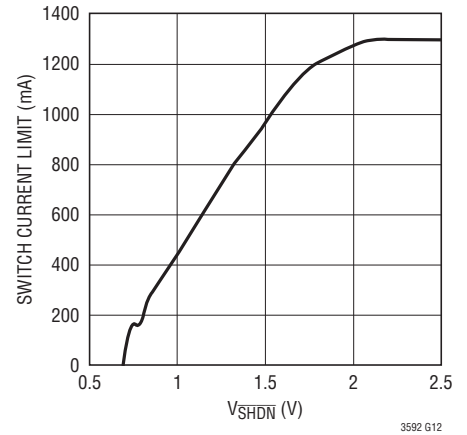

Frequency Foldback

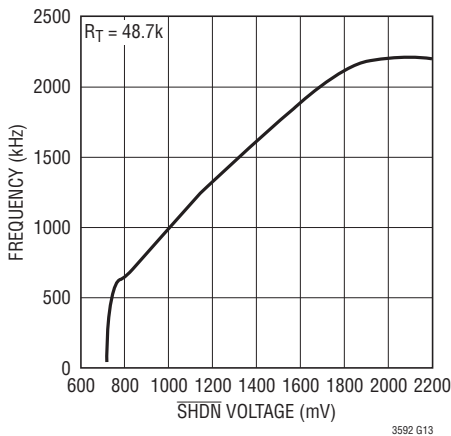

Switch Current Limit

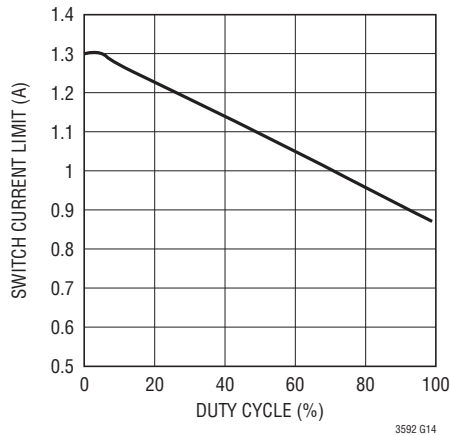

Switch Current Limit

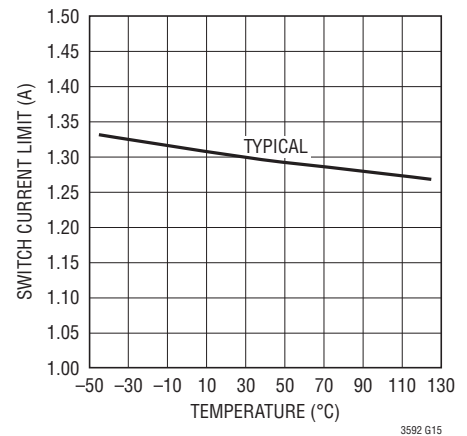

Operating Waveforms

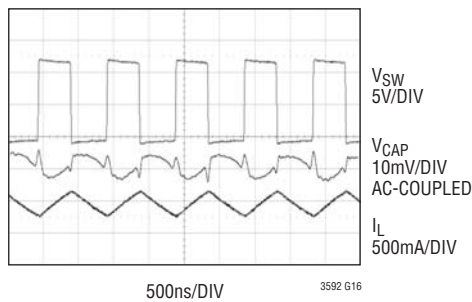

Operating Waveforms, Discontinuous Mode

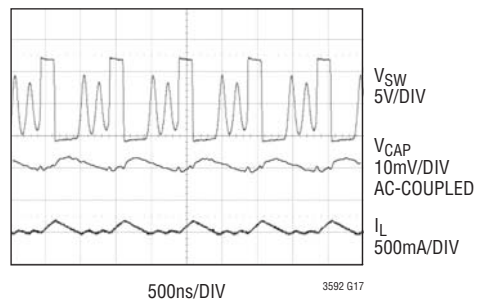

TYPICAL PERFORMANCE CHARACTERISTICS ($T_A = 25^\circ\text{C}$, unless otherwise noted)

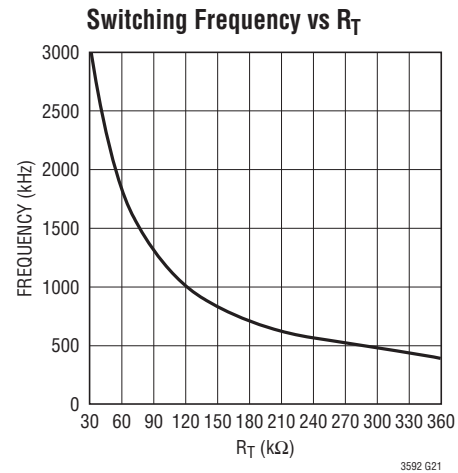
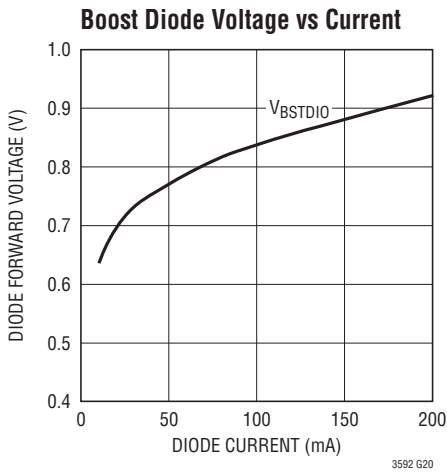
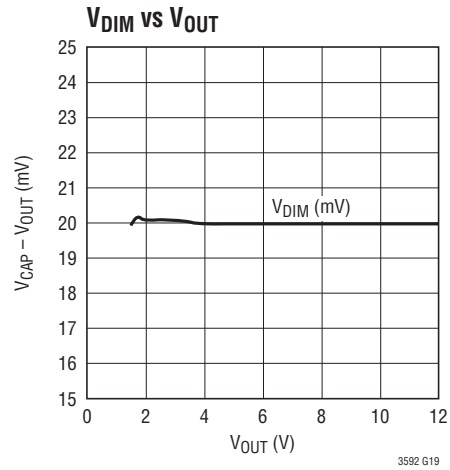
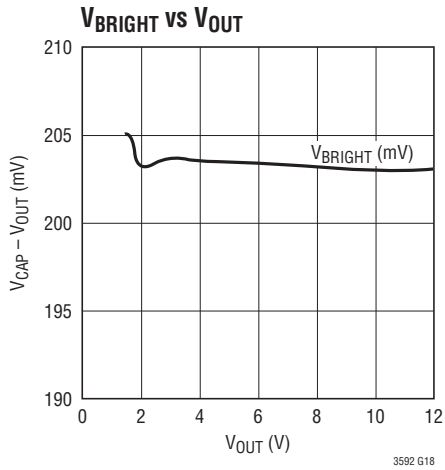

PIN FUNCTIONS

R_T (Pin 1): Programs the frequency of the internal oscillator. Connect a resistor from R_T to ground. Refer to Table 1 or the Typical Performance Characteristics for resistor values that result in desired oscillator frequencies.

BRIGHT (Pin 2): Used to program a 10:1 dimming ratio for the LED current. Drive this pin above 1.4V to command maximum intensity or below 0.3V to command minimum intensity. This pin can be PWMed at 150Hz for brightness control between the 1x and 10x current levels.

SHDN (Pin 3): Used to shutdown the switching regulator and the internal bias circuits. This pin can be PWMed at 150Hz for brightness control.

V_{IN} (Pin 4): Supplies current to the LT3592's internal circuitry and to the internal power switches. Must be locally bypassed. For automotive applications, a pi network with a cap from V_{IN} to GND, a series inductor connected between V_{IN} and the power source, and another cap from the far end of the inductor to GND is recommended.

DA (Pin 5): Allows the external catch diode current to be sensed to prevent current runaway, such as when V_{IN} is high and the duty cycle is very low. Connect this pin to the anode of the external catch Schottky diode.

SW (Pin 6): The SW pin is the output of the internal power switch. Connect this pin to the inductor and the cathode of the switching diode.

BOOST (Pin 7): Provides a drive voltage, higher than the input voltage to the internal bipolar NPN power switch. BOOST will normally be tied to the SW pin through a 0.1μF

capacitor. An internal Schottky is provided for the boost function and an external diode is not needed. An external Schottky diode should be connected between BOOST and CAP for single LED applications or whenever a higher BOOST voltage is desired.

CAP (Pin 8): Output of the step-down converter and also an input to the LED current sense amplifier. Connect the filter capacitor, inductor, and the top of the external LED current sense resistor to this pin.

OUT (Pin 9): Drives the LED or LEDs and is the other input to the LED current sense amplifier. Connect this pin to the anode of the top LED in the string, the bottom of the external LED current sense resistor, and the top of the V_{FB} resistor divider.

V_{FB} (Pin 10): The feedback node for the output voltage control loop. Tie this node to a resistor divider between OUT and GND to set the maximum output voltage of the step-down converter according to the following formula:

$$V_{OUT} = 1.21 \cdot \frac{R1 + R2}{R2}$$

where R1 connects between OUT and V_{FB} and R2 connects between V_{FB} and GND.

Exposed Pad (Pin 11): Ground. The underside exposed pad metal of the package provides both electrical contact to ground and good thermal contact to the printed circuit board. The device must be soldered to the circuit board for proper operation.

BLOCK DIAGRAM

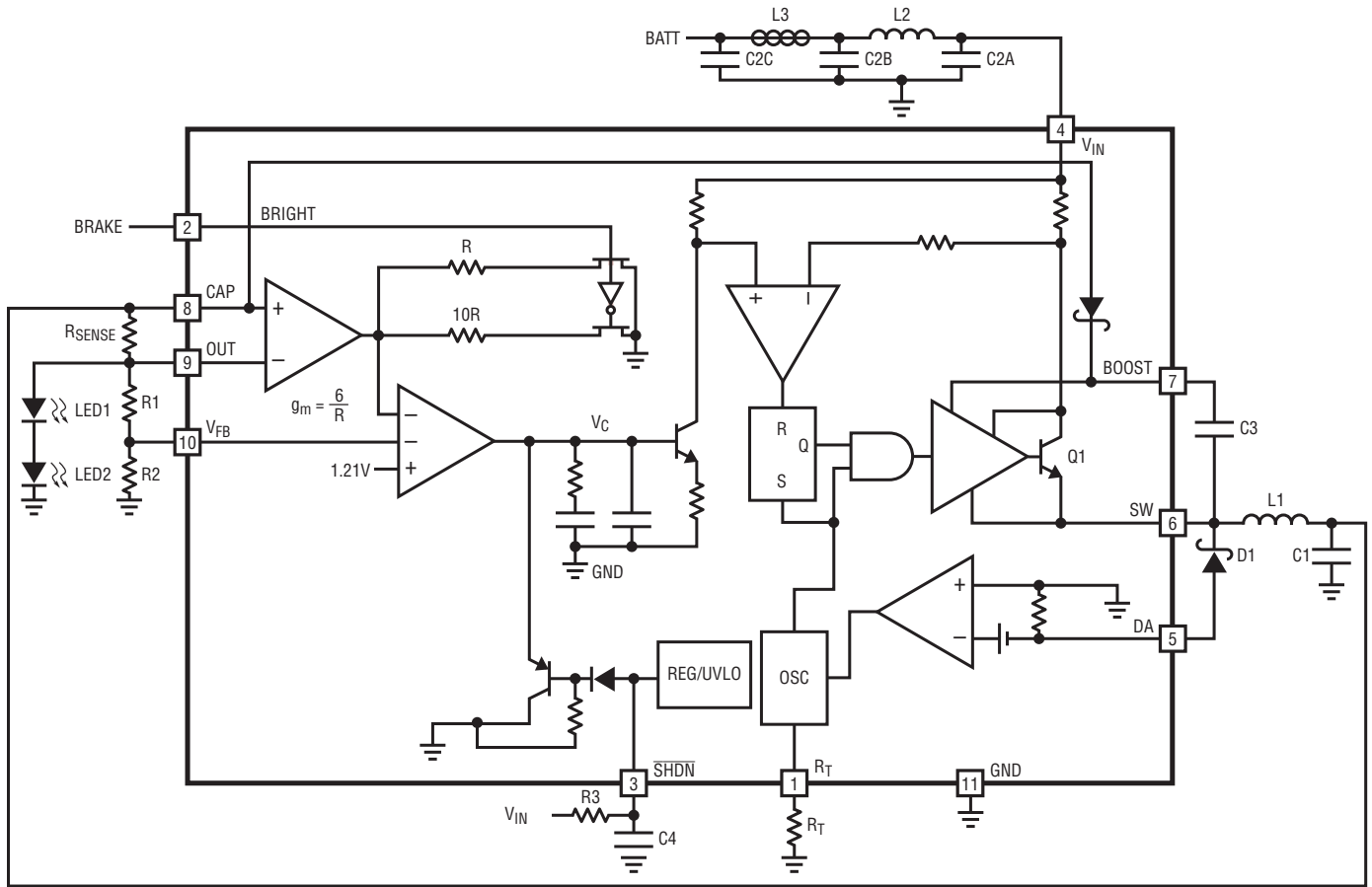

3592 BD

OPERATION

The LT3592 is a constant frequency, current mode step-down LED driver. An internal oscillator that is programmed by a resistor from the R_T pin to ground enables an RS flip-flop, turning on the internal 1.25A power switch Q1. An amplifier and comparator monitor the current flowing between the V_{IN} and SW pins, turning the switch off when this current reaches a level determined by the voltage at V_C . An error amplifier that servos the V_C node has two inputs, one from a voltage measurement and one from a current measurement.

An instrumentation amplifier measures the drop across an external current sense resistor between the CAP and OUT pins and applies a gain of 60 (BRIGHT low for dim mode) or 6 (BRIGHT high for bright mode) to this signal and presents it to one negative error amp input. The output of a external resistor divider between OUT and ground is tied to the V_{FB} pin and presented to a second negative error amp input. Whichever input is higher in voltage will end up controlling the loop, so a circuit in which current control is desired (as for driving a LED) will be set up such that the output of the instrumentation amp will be higher than the V_{FB} pin at the current level that is desired. The voltage feedback loop will act to limit the output voltage and prevent circuit damage if an LED should go open circuit.

The positive input to the error amp is a 1.21V reference, so the voltage loop forces the V_{FB} pin to 1.21V and the current loop forces the voltage difference between CAP and OUT to be 200mV for BRIGHT mode and 20mV for DIM mode. A rise in the output of the error amplifier results in a increase in output current, and a fall in the

error amplifier output means less output current. Current limit is provided by an active clamp on the V_C node, and this node is also clamped to the \overline{SHDN} pin. Soft-start is implemented by ramping the \overline{SHDN} pin using an external resistor and capacitor.

An internal regulator provides power to the control circuitry and also includes an undervoltage lockout to prevent switching when V_{IN} is less than 3.25V. If \overline{SHDN} is low, the output is disconnected and the input current is less than 2 μ A.

The switch driver operates from the input of the BOOST pin. An external capacitor and internal diode are used to generate a voltage at the BOOST pin that is higher than the input supply, which allows the driver to fully saturate the internal bipolar NPN power switch for efficient operation. An external diode can be used to make the BOOST drive more effective at low output voltage.

The oscillator reduces the LT3592's operating frequency when the voltage at the OUT pin is low. This frequency foldback helps to control the output current during startup and overload.

The anode of the catch diode for the step-down circuit is connected to the DA pin to provide a direct sense of the current in this device. If this diode's current goes above a level set by an internal catch diode current limit circuit, the oscillator frequency is slowed down. This prevents current runaway due to minimum on time limitations at high V_{IN} voltages. This function can easily be disabled by tying the DA pin and the catch diode anode to ground.

APPLICATIONS INFORMATION

Oscillator

The frequency of operation is programmed by an external resistor from R_T to ground. Table 1 shows R_T values for commonly used oscillator frequencies, and refer to the Typical Performance Characteristics curve for other values.

Table 1. R_T Values for Selector Oscillator Frequencies

f_{osc}	R_T
400kHz	357k
900kHz	140k
2.2MHz	48.7k

FB Resistor Network

The output voltage limit is programmed with a resistor divider between the output and the V_{FB} pin. This is the voltage that the output will be clamped to in case the LED goes open circuit. Choose the resistors according to

$$R1 = R2([V_{OUT}/1.21V] - 1)$$

Be sure to choose V_{OUT} such that it does not interfere with the operation of the current control loop; it should be set at least 10% above the maximum expected LED voltage for the selected BRIGHT output current. $R2$ should be 20k or less to avoid bias current errors. An optional phase-lead capacitor of 22pF between V_{OUT} and V_{FB} reduces light-load ripple.

Output Current Selection

The output current levels are programmed by the value of the external current sense resistor between CAP and OUT.

The BRIGHT mode current is given by:

$$I_{BRIGHT} = 200mV/R_{SENSE}$$

The DIM mode current is 10% of the BRIGHT mode value. The maximum allowed DC value of the BRIGHT mode current is 500mA. When the recommended component values are used in a 900kHz 2 LED application, the transient from switching between BRIGHT and DIM currents will be less than 50 μ s in duration.

The sense resistor used should exhibit a low TC to keep the LED current from drifting as the operating temperature changes.

The BRIGHT pin can tolerate voltages as high as 36V and can be safely tied to V_{IN} even in high voltage applications, but it also has a low threshold voltage (~0.7V) that allows it to interface to logic level control signals.

Input Voltage Range

The maximum allowed input voltage for the LT3592 is 36V. The minimum input voltage is determined by either the LT3592's minimum operating voltage of 3.6V or by its maximum duty cycle. The duty cycle is the fraction of time that the internal switch is on and is determined by the input and output voltages:

$$DC = \frac{V_{OUT} + V_D}{V_{IN} - V_{SW} + V_D}$$

where V_D is the forward voltage drop of the catch diode (~0.4V) and V_{SW} is the voltage drop of the internal switch

Table 2. Inductor Vendor Information

SUPPLIER	PHONE	FAX	WEBSITE
Panasonic	(800) 344-2112		www.panasonic.com/industrial/components/components.html
Vishay	(402) 563-6866	(402) 563-6296	www.vishay.com/resistors
Coilcraft	(847) 639-6400	(847) 639-1469	www.coilcraft.com
CoEv Magnetics	(800) 227-7040	(650) 361-2508	www.circuitprotection.com/magnetics.asp
Murata	(814) 237-1431 (800) 831-9172	(814) 238-0490	www.murata.com
Sumida	USA: (847) 956-0666 Japan: 81(3) 3607-5111	USA: (847) 956-0702 Japan: 81(3) 3607-5144	www.sumida.com
TDK	(847) 803-6100	(847) 803-6296	www.component.tdk.com
TOKO	(847) 297-0070	(847) 699-7864	www.tokoam.com

APPLICATIONS INFORMATION

(~0.4V at maximum load). This leads to a minimum input voltage of:

$$V_{IN(MIN)} = \frac{V_{OUT} + V_D}{DC_{MAX}} - V_D + V_{SW}$$

with $DC_{MAX} = 0.90$.

The maximum input voltage is determined by the absolute maximum ratings of the V_{IN} and BOOST pins. The continuous mode operation, the maximum input voltage is determined by the minimum duty cycle, which is dependent upon the oscillator frequency:

$$DC_{MIN} = f_{OSC} \cdot 70nsec$$

$$V_{IN(MAX)} = \frac{V_{OUT} + V_D}{DC_{MIN}} - V_D + V_{SW}$$

Note that this is a restriction on the operating input voltage for continuous mode operation. The circuit will tolerate transient inputs up to the absolute maximum of the V_{IN} and BOOST pins. The input voltage should be limited to

the V_{IN} absolute maximum range (36V) during overload conditions (short circuit or startup).

Minimum On Time

The LT3592 will still regulate the output properly at input voltages that exceed $V_{IN(MAX)}$ (up to 36V); however, the output voltage ripple increases as the input voltage is increased.

Figure 1 illustrates switching waveforms in a 2.2MHz single red LED application near $V_{IN(MAX)} = 24V$.

As the input voltage is increased, the part is required to switch for shorter periods of time. Delays associated with turning off the power switch dictate the minimum on time of the part. The minimum on time for the LT3592 is ~70ns. Figure 2 illustrates the switching waveforms when the input voltage is increased to $V_{IN} = 26V$.

Now the required on time has decreased below the minimum on time of 70ns. Instead of the switch pulse width becoming narrower to accommodate the lower duty cycle requirement, the switch pulse width remains fixed at 70ns. In Figure 2, the inductor current ramps up to a value exceeding the load current and the output ripple increases to about 70mV. The part then remains off until the output voltage dips below the programmed value before it switches again.

Provided that the load can tolerate the increases output voltage ripple and the the components have been properly selected, operation about $V_{IN(MAX)}$ is safe and will not damage the part. Figure 3 illustrates the switching waveforms when the input voltage is increased to 36V.

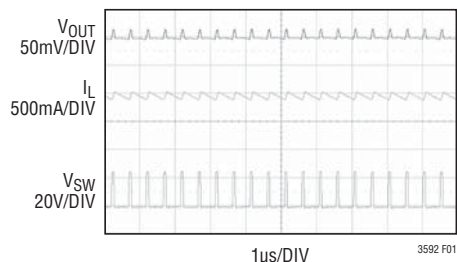

Figure 1.

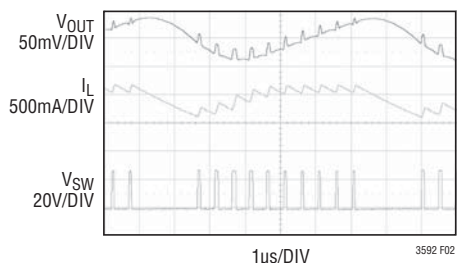

Figure 2.

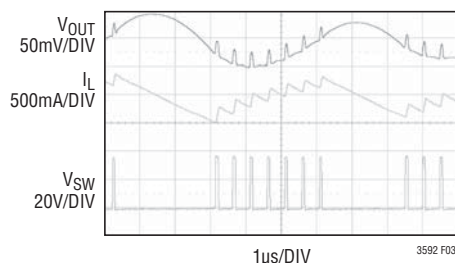

Figure 3.

APPLICATIONS INFORMATION

As the input voltage increases, the inductor current ramps up more quickly, the number of skipped pulses increases, and the output voltage ripple increases. For operation above $V_{IN(MAX)}$, the only component requirement is that they be adequately rated for operation at the intended voltage levels.

The LT3592 is robust enough to survive prolonged operation under these conditions as long as the peak inductor current does not exceed 1.2A. Inductor saturation due to high current may further limit performance in this operating regime.

Inductor Selection and Maximum Output Current

A good first choice for the inductor value is:

$$L = 1.2A \cdot \frac{(V_{OUT} + 0.2V + V_D)}{f}$$

where V_D is the forward voltage drop of the catch diode ($\sim 0.4V$), f is the switching frequency in MHz and L is in μH . With this value, there will be no subharmonic oscillation for applications with 50% or greater duty cycle. For low duty cycle applications in which V_{IN} is more than three times V_{OUT} , a good guide for the minimum inductor value is

$$L = 1.7 \cdot \left(\frac{(V_{IN} - V_{OUT} - 0.2V)}{V_{IN} - V_{SW} + V_D} \right) \cdot \left(\frac{(V_{OUT} + 0.2V + V_D)}{f} \right)$$

where V_{SW} is the switch voltage drop (about 0.3V at 500mA). The inductor's RMS current rating must be greater than your maximum load current and its saturation current should be about 30% higher. For robust operation in fault conditions, the saturation current should be above 1.5A. To keep efficiency high, the series resistance (DCR) should be less than 0.1 Ω . Table 2 lists several inductor vendors.

Of course, such a simple design guide will not always result in the optimum inductor for your application. A larger value provides a higher maximum load current and reduces output voltage ripple at the expense of a slower transient response. If your load is lower than 500mA, then you can decrease the value of the inductor and operate with higher ripple current. This allows you to use a physically smaller inductor, or one with a lower DCR resulting in higher efficiency. There are several graphs in the Typical Performance

Characteristics section of this data sheet that show the maximum load current as a function of input voltage and inductor value for several popular output voltages. Low inductance may result in discontinuous mode operation, which is acceptable, but further reduces maximum load current. For details of the maximum output current and discontinuous mode operation, see Linear Technology Application Note 44.

Catch Diode

Depending on load current, a 500mA to 1A Schottky diode is recommended for the catch diode, D1. The diode must have a reverse voltage rating equal to or greater than the maximum input voltage. The ON Semiconductor MBRA140T3 and Central Semiconductor CMMSH1-40 are good choices, as they are rated for 1A continuous forward current and a maximum reverse voltage of 40V.

Input Filter Network

For applications that only require a capacitor, bypass V_{IN} with a 1 μF or higher ceramic capacitor of X7R or X5R type. Y5V types have poor performance over temperature and applied voltage and should not be used. A 1 μF ceramic capacitor is adequate to bypass the LT3592 and will easily handle the ripple current. However, if the input power source has high impedance, or there is significant inductance due to long wires or cables, additional bulk capacitance might be necessary. The can be provided with a low performance (high ESR) electrolytic capacitor in parallel with the ceramic device.

Some applications, such as those in automobiles, may require extra filtering due to EMI/EMC requirements. In these applications, very effective EMI filtering can be provided by a capacitor to ground right at the source voltage, a series ferrite bead, and a pi filter composed of a capacitor to ground, a series inductor, and another capacitor directly from the device pin to ground (see the Block Diagram for an example). Typical values for the filter components are 10nF for C2C, a ferrite bead that is $\sim 220\Omega$ at 100MHz for L2, 3.3 μF for C2B, 10 μH for L3, and 1 μF for C2A.

Step-down regulators draw current from the input supply in pulses with very fast rise and fall times. The input capacitor is required to reduce the resulting voltage ripple

APPLICATIONS INFORMATION

at the LT3592 and to force this very high frequency switching current into a tight local loop, minimizing EMI. A 1 μ F capacitor is capable of this task, but only if it is placed close to the LT3592 and catch diode (see the PCB layout section). A second precaution regarding the ceramic input capacitor concerns the maximum input voltage rating of the LT3592. A ceramic input capacitor combined with trace or cable inductance forms a high quality (underdamped) tank circuit. If the LT3592 circuit is plugged into a live supply, the input voltage can ring to twice its nominal value, possibly exceeding the LT3592's voltage rating. This situation can easily be avoided, as discussed in the Hot Plugging Safety section. For more details, see Linear Technology Application Note 88.

Output Capacitor

For most 2.2MHz LED applications, a 3.3 μ F or higher output capacitor is sufficient for stable operation. A 900kHz application should use a 4.7 μ F or higher output capacitor. 400kHz applications require a 22 μ F or higher output capacitor. The minimum recommended values should provide an acceptable (if somewhat underdamped) transient response, but larger values can always be used when extra damping is required or desired.

The output capacitor filters the inductor current to generate an output with low voltage ripple. It also stores energy in order to satisfy transient loads and stabilizes the LT3592's control loop. Because the LT3592 operates at a high frequency, minimal output capacitance is necessary. In addition, the control loop operates well with or without the presence of significant output capacitor equivalent series resistance (ESR). Ceramic capacitors, which achieve very low output ripple and small circuit size, are therefore an option.

You can estimate output ripple with the following equation:

$$V_{\text{RIPPLE}} = \frac{\Delta I_{\text{LP-P}}}{8 \cdot f \cdot C_{\text{OUT}}}$$

where $\Delta I_{\text{LP-P}}$ is the peak-to-peak ripple current in the inductor. The RMS content of this ripple is very low, so the RMS current rating of the output capacitor is usually not a concern. It can be estimated with the formula:

$$I_{\text{C(RMS)}} = \frac{\Delta I_{\text{L}}}{\sqrt{12}}$$

The low ESR and small size of ceramic capacitors make them the preferred type for LT3592 applications. Not all ceramic capacitors are the same, though. Many of the higher value ceramic capacitors use poor dielectrics with high temperature and voltage coefficients. In particular, Y5V and Z5U types lose a large fraction of their capacitance with applied voltage and at temperature extremes.

Because loop stability and transient response depend on the value of C_{OUT} , this loss may be unacceptable. Use X7R and X5R types. Table 3 lists several capacitor vendors.

Figure 4 shows the transient response of the LT3592 when switching between DIM and BRIGHT current levels with two output capacitor choices. The output load is two series Luxeon K2 Red LEDs, the DIM current is 50mA and the BRIGHT current is 500mA, and the circuit is running at 900kHz. The upper photo shows the recommended 4.7 μ F value. The second photo shows the improved response resulting from a larger output capacitor.

Table 3. Capacitor Vendor Information

SUPPLIER	PHONE	FAX	WEBSITE
AVX	(803) 448-9411	(803) 448-1943	www.avxcorp.com
Sanyo	(619) 661-6322	(619) 661-1055	www.sanyovideo.com
Taiyo Yuden	(408) 573-4150	(408) 573-4159	www.t-yuden.com
TDK	(847) 803-6100	(847) 803-6296	www.component.tdk.com

APPLICATIONS INFORMATION

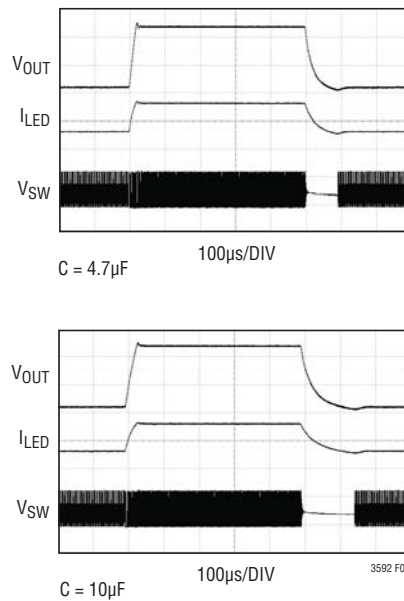

Figure 4. Transient Load Response of the LT3592 with Different Output Capacitors

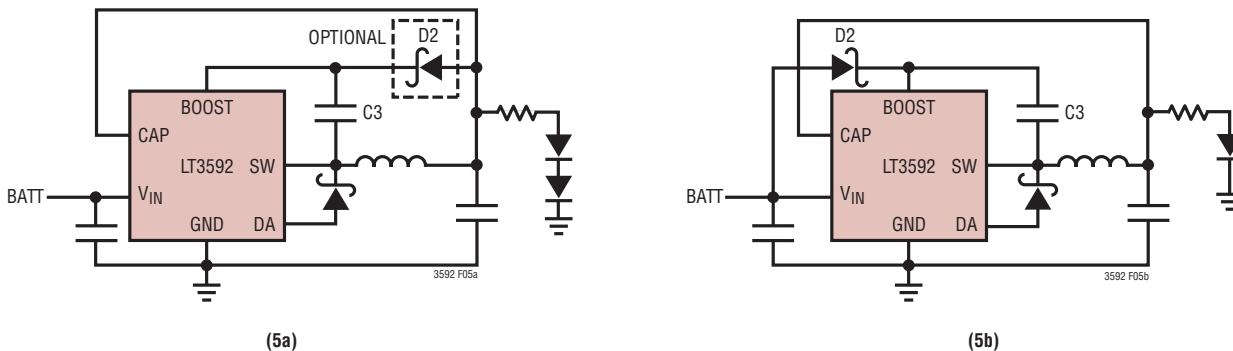

Figure 5. Two Circuits for Generating the Boost Voltage

BOOST Pin Considerations

The capacitor C3 and an internal Schottky diode from the CAP to the BOOST pin are used to generate a boost voltage that is higher than the input voltage. An external fast switching Schottky diode (such as the BAS40) can be used in parallel with the internal diode to make this boost circuit even more effective. In most cases, a 0.1µF capacitor works well for the boost circuit. The BOOST pin must be at least 2.5V above the SW pin for best efficiency. For output voltages above 12V, use a 0.1µF cap and an external boost diode (such as a BAS40) connected in

parallel with the internal Schottky diode, anode to CAP and cathode to BOOST. For outputs between 3.3V and 12V, the 0.1µF cap and the internal boost diode will be effective. For 3V to 3.3V outputs, use a 0.22µF capacitor. For output between 2.5V and 3V, use a 0.47µF capacitor and an external Schottky diode connected as shown in Figure 5a. For lower output voltages, the external boost diode’s anode can be tied to the input voltage. This connection is not as efficient as the others because the BOOST pin current comes from a higher voltage. The user must also be sure that the maximum voltage rating of the BOOST pin is not exceeded.

APPLICATIONS INFORMATION

The minimum operating voltage of an LT3592 application is limited by the undervoltage lockout (UVLO, ~3.25V) and by the maximum duty cycle as outlined above. For proper startup, the minimum input voltage is also limited by the boost circuit. If the input voltage is ramped slowly, or the LT3592 is turned on with its $\overline{\text{SHDN}}$ pin when the output is already in regulation, then the boost capacitor might not be fully charged. Because the boost capacitor is charged with the energy stored in the inductor, the circuit will rely on some minimum load current to get the boost circuit running properly. This minimum load generally goes to zero once the circuit has started. Figure 6 shows a plot of minimum input voltage needed to start with a 500mA output current versus output voltage with LED loads. For LED applications, the output voltage will typically drop rapidly after start due to diode heating, but this is not a concern because the voltage to run is lower than the voltage to start. The plots show the worst case situation when V_{IN} is ramping very slowly. For a lower startup voltage, the boost diode's anode can be tied to V_{IN} , but

this restricts the input range to one-half of the absolute maximum rating of the BOOST pin.

At light loads, the inductor current becomes discontinuous and the effective duty cycle can be very high. This reduces the minimum input voltage to about 400mV above V_{CAP} . At higher load currents, the inductor current is continuous and the duty cycle is limited by the maximum duty cycle of the LT3592, requiring a higher input voltage to maintain regulation.

Soft-Start

The $\overline{\text{SHDN}}$ pin can be used to soft-start the LT3592, reducing the maximum input current during startup. The $\overline{\text{SHDN}}$ pin is driven through an external RC filter to create a voltage ramp at this pin. Figure 7 shows the startup waveforms with and without the soft-start circuit. By choosing a large RC time constant, the peak startup current can be reduced to programmed LED current, with no overshoot. Choose the value of the resistor so that it can supply 20 μA when the $\overline{\text{SHDN}}$ pin reaches 2.3V.

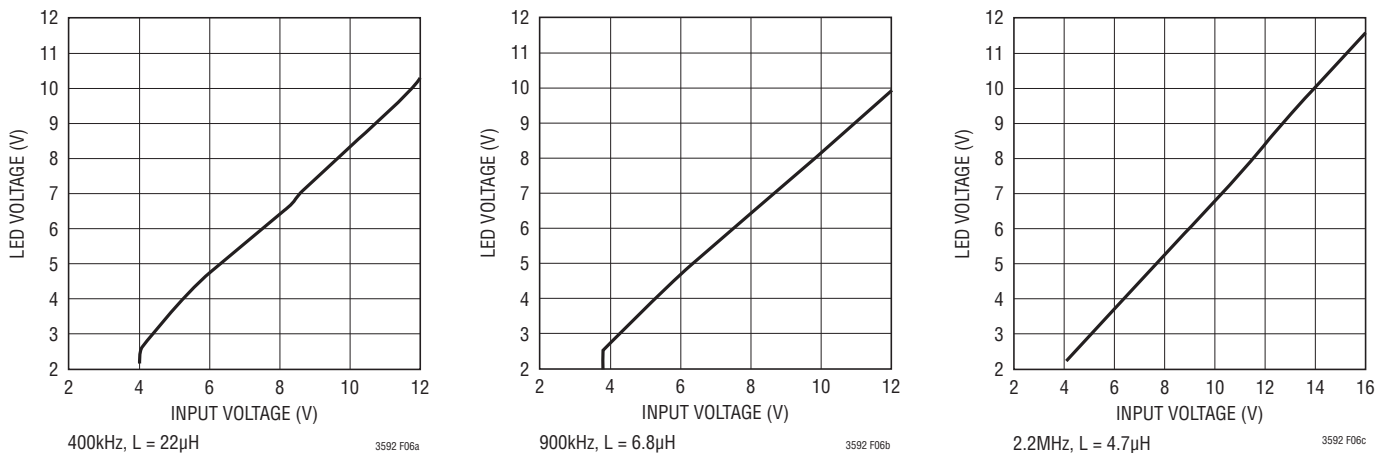

Figure 6. Input Voltage Needed to Start at 500mA Output Current vs LED Voltage

APPLICATIONS INFORMATION

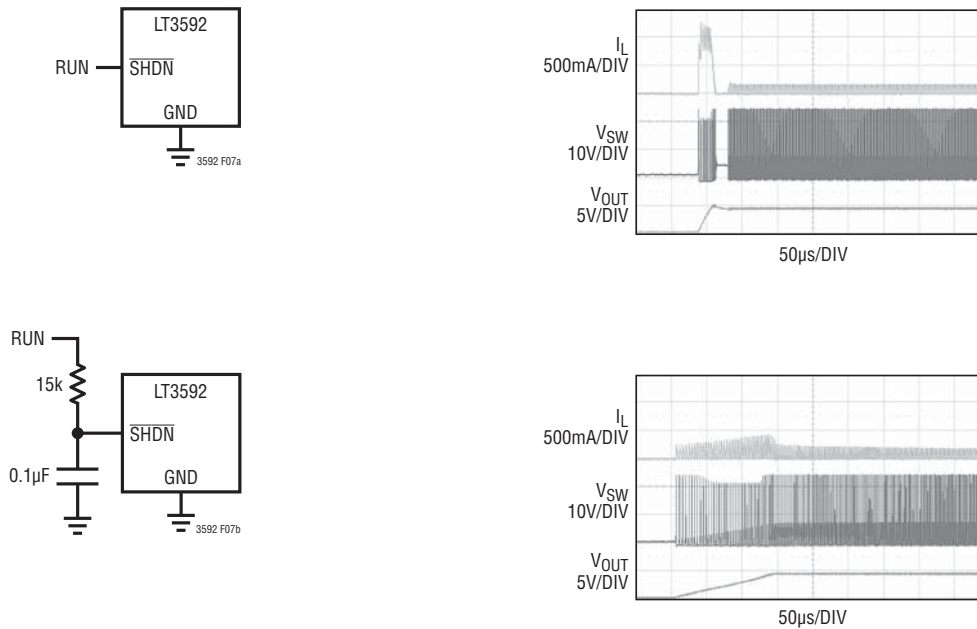

Figure 7. To Soft-Start the LT3592, Add a Resistor and Capacitor to the SHDN Pin

Shorted and Open LED Protection

In case of a shorted LED string or the OUT pin being shorted to ground by any means, the current loop will help to limit the output current for many conditions, but the switch current may still reach the switch current limit on some cycles despite the actions of the current loop. For some conditions (especially cold), the output current for shorted OUT will only be limited by the switch current limit (which can be as high as 1.5A) and the switching frequency foldback that occurs when OUT is close to ground, and the current control loop will have little to no effect. The total power dissipation will be quite low in either case due to the frequency foldback and the fact that the small current sense resistor will effectively be the output load for shorted OUT. Peak switch and inductor currents will be high, but the peaks will be brief and well separated due to the lowered operating frequency. The main concern in this condition is that the output inductor not saturate and force the switch into an unsafe operating condition of simultaneous high current and high voltage drop. If the current sense resistor between CAP and OUT

becomes shorted or the CAP pin is shorted to ground, the peak output current will be limited by the internal switch current limit, which could be as high as 1.5A.

If an LED goes open circuit, the voltage control loop through the R1-R2 resistor divider to FB will take control and prevent the output voltages from flying up close to V_{IN} . Program the desired open circuit voltage to a value below the absolute maximum for the CAP and OUT pins but well above the maximum possible forward drop of the LED at the programmed BRIGHT current.

Reversed Input Protection

In some systems, the output will be held high when the input to the LT3592 is absent. This may occur in battery charging applications or in battery backup systems where a battery or some other supply is diode ORed with the LT3592's output. If the V_{IN} pin is allowed to float and the SHDN pin is held high (either by a logic signal or because it is tied to V_{IN}), then the LT3592's internal circuitry will draw its quiescent current through its SW pin. This is fine if the system can tolerate a few mA in this state. If you

APPLICATIONS INFORMATION

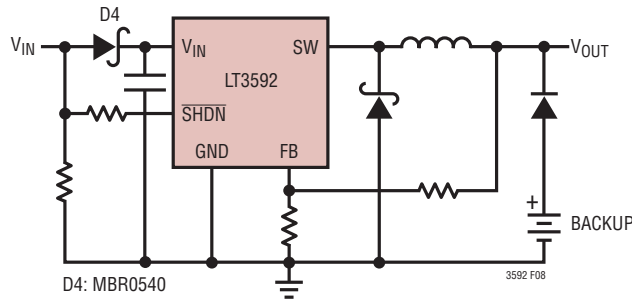

Figure 8. Circuit to Address Reversed Input and Backpowering Issues

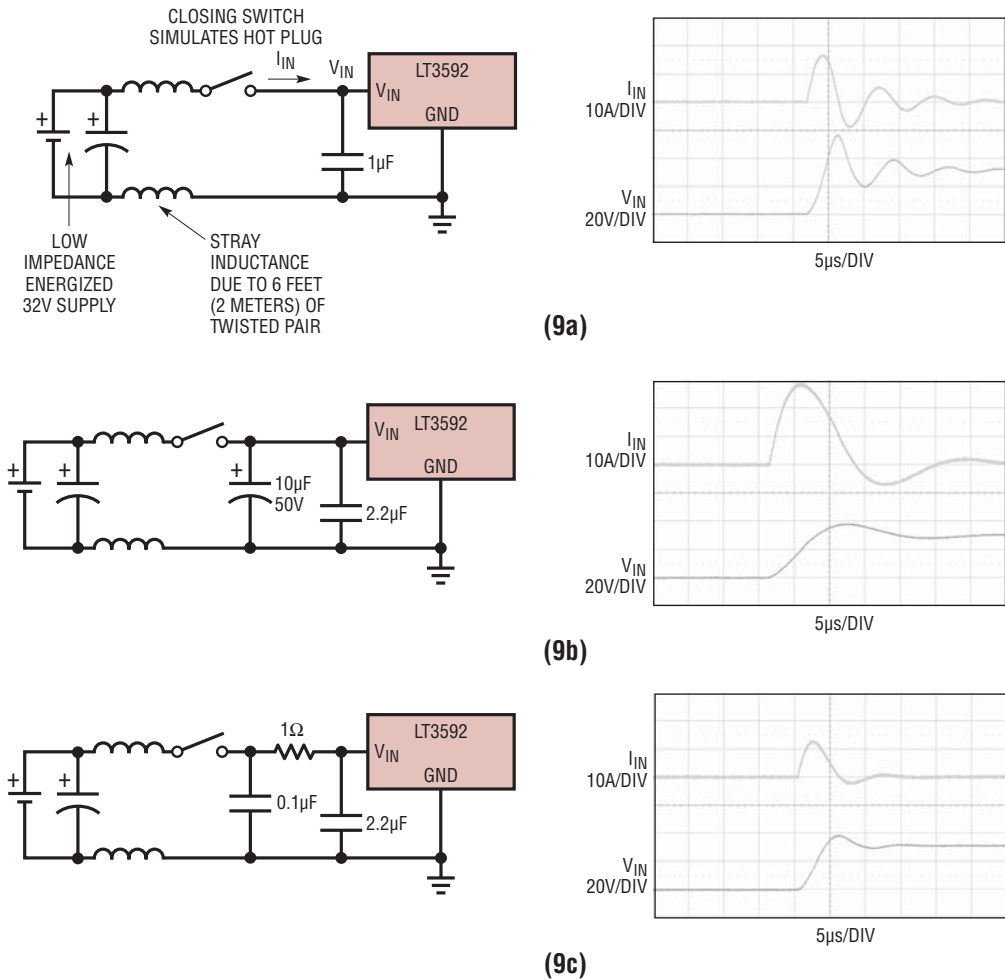

Figure 9. A Well Chosen Input Network Prevents Input Voltage Overshoot and Ensures Reliable Operation When the LT3592 is Connected to a Live Supply

3493 F09

APPLICATIONS INFORMATION

ground the $\overline{\text{SHDN}}$ pin, the SW pin current will drop to essentially zero. However, if the V_{IN} pin is grounded while the output is held high, then parasitic diodes inside the LT3592 can pull large currents from the output through the SW pin and the V_{IN} pin. Figure 8 shows a circuit that will run only when the input voltage is present and that protects against a shorted or reversed input.

Hot Plugging Safely

The small size, robustness, and low impedance of ceramic capacitors make them an attractive option for the input bypass capacitor of LT3592 circuits. However, these capacitors can cause problems if the LT3592 is plugged into a live supply (see Linear Technology Application Note 88 for a complete discussion). The low loss ceramic capacitor combined with stray inductance in series with the power source forms an underdamped tank circuit, and the voltage at the V_{IN} pin of the LT3592 can ring to twice the nominal input voltage, possibly exceeding the LT3592's rating and damaging the part. If the input supply is poorly controlled or the user will be plugging the LT3592 into an energized supply, the input network should be designed to prevent this overshoot.

Figure 9 shows the waveforms that result when an LT3592 circuit is connected to a 32V supply through six feet of 24 gauge twisted pair. The first plot is the response with a $1\mu\text{F}$ ceramic capacitor at the input. The input voltage rings as high as 56V and the input current peaks at 16A.

One method of damping the tank circuit is to add another capacitor with a series resistor to the circuit. In Figure 9b, a tantalum chip capacitor has been added. This capacitor's high equivalent series resistance (ESR) damps the circuit and eliminates the voltage overshoot. The extra capacitor improves low frequency ripple filtering and can slightly improve the efficiency of the circuit, though it is likely to be the largest component in the circuit. An alternate solution is shown in Figure 9c. A 1Ω resistor is added in series with the input to eliminate the voltage overshoot (it also reduces the peak input current). A $0.1\mu\text{F}$ capacitor improves high frequency filtering. This solution is smaller and less expensive than the tantalum capacitor. For high input voltages, the impact of the 1Ω resistor on efficiency

is minor, reducing it by less than one half percent for a two red series LED load in BRIGHT mode operating from 32V.

Frequency Compensation

The LT3592 uses current mode control to regulate the loop, whether the current control or voltage control loop is active. This simplifies loop compensation. In particular, the LT3592 does not require the ESR of the output capacitor for stability, allowing the use of ceramic capacitors to achieve low output ripple and small circuit size. A low ESR output capacitor will typically provide for a greater margin of circuit stability than an otherwise equivalent capacitor with higher ESR, although the higher ESR will tend to provide a faster loop response. Figure 10 shows an equivalent circuit for the LT3592 control loops, both for current and voltage mode. Both use the same error amplifier and power section, but an additional voltage gain amp is used in conjunction with the external current sense resistor to implement output current control. The error amplifier is a transconductance type with finite output impedance. The power section, consisting of the modulator, power switch, and inductor, is modeled as a transconductance amplifier generating an output current proportional to the voltage at the V_C node. Note that the output capacitor integrates this current, and that the capacitor on the V_C node (C_C) integrates the error amplifier output current, resulting in

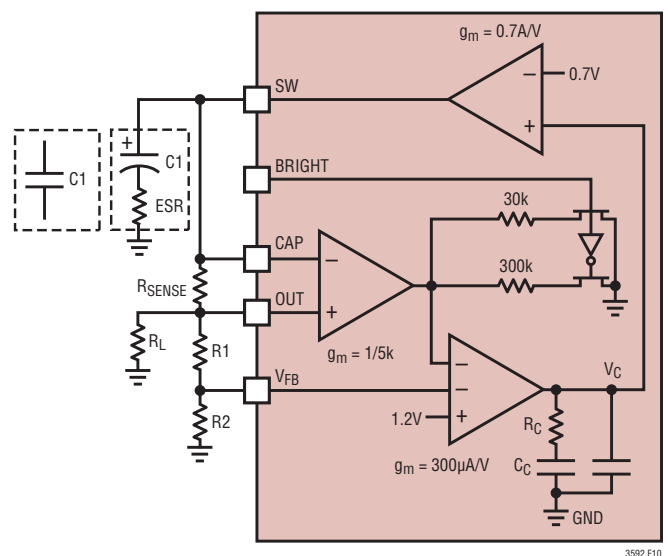

Figure 10. Model for Loop Response

APPLICATIONS INFORMATION

two poles in the loop. R_C provides a zero. With the recommended output capacitor, the loop crossover occurs above the $R_C C_C$ zero. This simple model works well as long as the value of the inductor is not too high and the loop crossover frequency is much lower than the switching frequency. With a larger ceramic capacitor that will have lower ESR, crossover may be lower and a phase lead capacitor (C_{PL}) across the feedback divider may improve the transient response. Large electrolytic capacitors may have an ESR large enough to create an additional zero, and the phase lead might not be necessary. If the output capacitor is different than the recommended capacitor, stability should be checked across all operating conditions, including DIM and BRIGHT current modes, voltage control via FB, input voltage, and temperature.

PCB Layout

For proper operation and minimum EMI, care must be taken during printed circuit board layout. Figure 11 shows the recommended component placement with trace, ground plane, and via locations. Note that large, switched currents flow in the LT3592's V_{IN} and SW pins, the catch diode (D1), and the input capacitor (C2). The loop formed by these components should be as small as possible and tied to system ground in only one place. These components, along with the inductor and output capacitor, should be placed on the same side of the circuit board, and their connections should be made on that layer. Place a local, unbroken ground plane below these components, and tie this ground plane to system ground at one location (ideally at the ground

terminal of the output capacitor C1). The SW and BOOST nodes should be as small as possible. Finally, keep the FB node small so that the ground pin and ground traces will shield it from the SW and BOOST nodes. Include vias near the exposed GND pad of the LT3592 to help remove heat from the LT3592 to the ground plane.

High Temperature Considerations

The die temperature of the LT3592 must be lower than the maximum rating of 125°C. This is generally not a concern unless the ambient temperature is above 85°C. For higher temperatures, extra care should be taken in the layout of the circuit to ensure good heat sinking at the LT3592. The maximum load current should be derated as the ambient temperature approaches 125°C. The die temperature is calculated by multiplying the LT3592 power dissipation by the thermal resistance from junction to ambient. Power dissipation within the LT3592 can be estimated by calculating the total power loss from an efficiency measurement and subtracting the catch diode loss. The resulting temperature rise at full load is nearly independent of input voltage. Thermal resistance depends upon the layout of the circuit board, but 76°C/W is typical for the 3mm × 2mm DFN (DDB10) package, and 38°C/W is typical for the MS10E package.

Higher Output Voltages

At higher output voltages, the choice of output capacitor becomes especially critical. Many small case size ceramic capacitors lose much of their rated capacitance well below

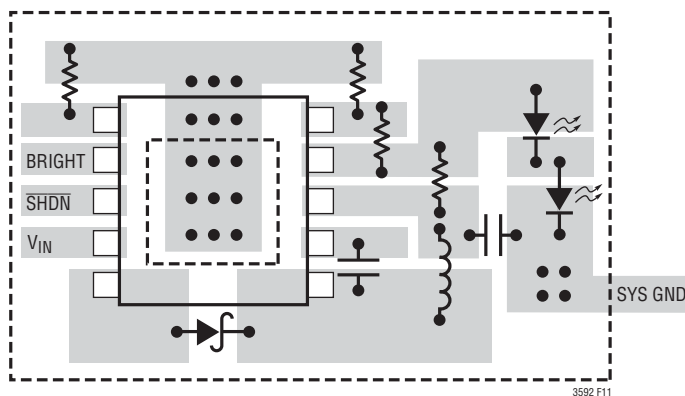

Figure 11. A Good PCB Layout Ensures Proper, Low EMI Operation

APPLICATIONS INFORMATION

their maximum voltage capability. If a capacitor with a lower voltage rating is found to not be stable in a design, it will often result in a smaller solution to choose a larger capacitor value of the same voltage rating than to choose one of the same capacitance and higher voltage rating. For example, a 10 μ F, 10V ceramic capacitor might be smaller than a 4.7 μ F, 16V part, if a 4.7 μ F, 10V capacitor is found to not be adequate in a given application. The LT3592HV can tolerate sustained output voltages of up to 25V. For output voltages above 12V, use an external Schottky diode for the boost circuit with the anode tied to CAP and the cathode tied to BOOST (as shown in Figure 13).

Transient Performance with Voltage Control Loop

The voltage control loop transient characteristics are similar to, but not identical to the current control loop. Figure 12 shows the transient for a 12V input application running at

900kHz with a 6.8 μ H inductor and a 4.7 μ F ceramic output capacitor. The LT3592 is in BRIGHT (500mA) mode but the current load is switched from 50mA to 450mA and back, so the current control loop is not active for either current level and the output voltage is regulated through the resistive voltage divider to the FB pin.

Other Linear Technology Publications

Application Notes AN19, AN35, and AN44 contain more detailed descriptions and design information for Step-down regulators and other switching regulators. The LT1376 data sheet has an extensive discussion of output ripple, loop compensation, and stability testing. Design Note DN100 shows how to generate a bipolar output supply using a Step-down regulator.

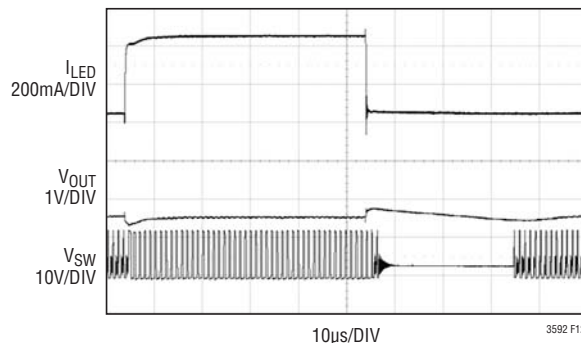

Figure 12. Switching Transient When Going from 50mA to 500mA Current and Back in Voltage Mode

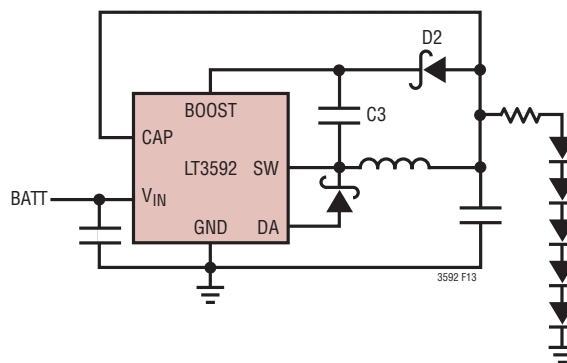
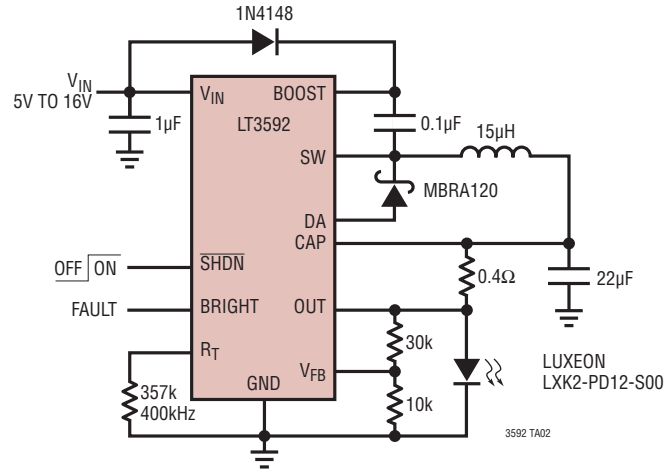

Figure 13. Boost Circuit with External Schottky Diode for Output Voltages Above 12V

TYPICAL APPLICATIONS

Single Red LED Driver with Boost Diode to V_{IN} Due to Low V_{OUT}



50mA/500mA Two Series Red LED Driver

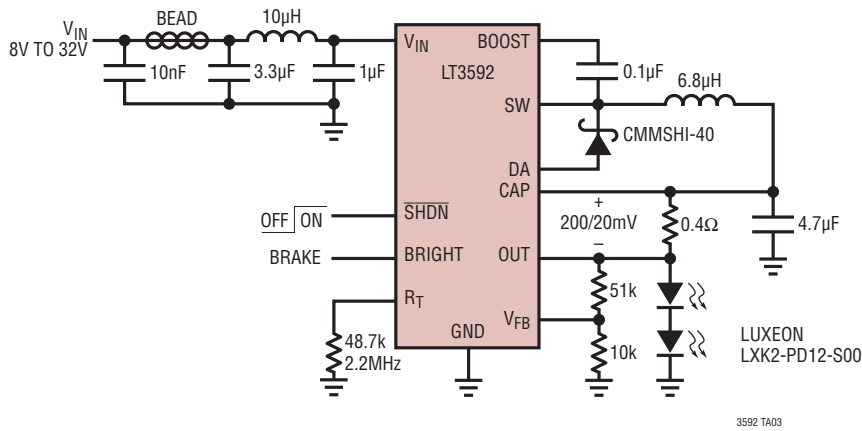

5V Supply with 500mA Current Limit

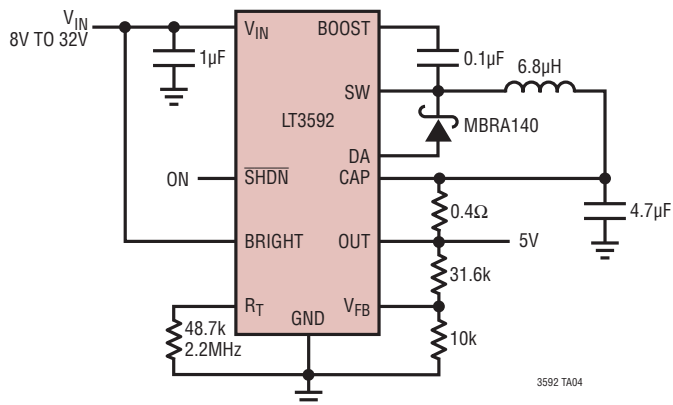

PACKAGE DESCRIPTION

MSE Package 10-Lead Plastic MSOP (Reference LTC DWG # 05-08-1664)

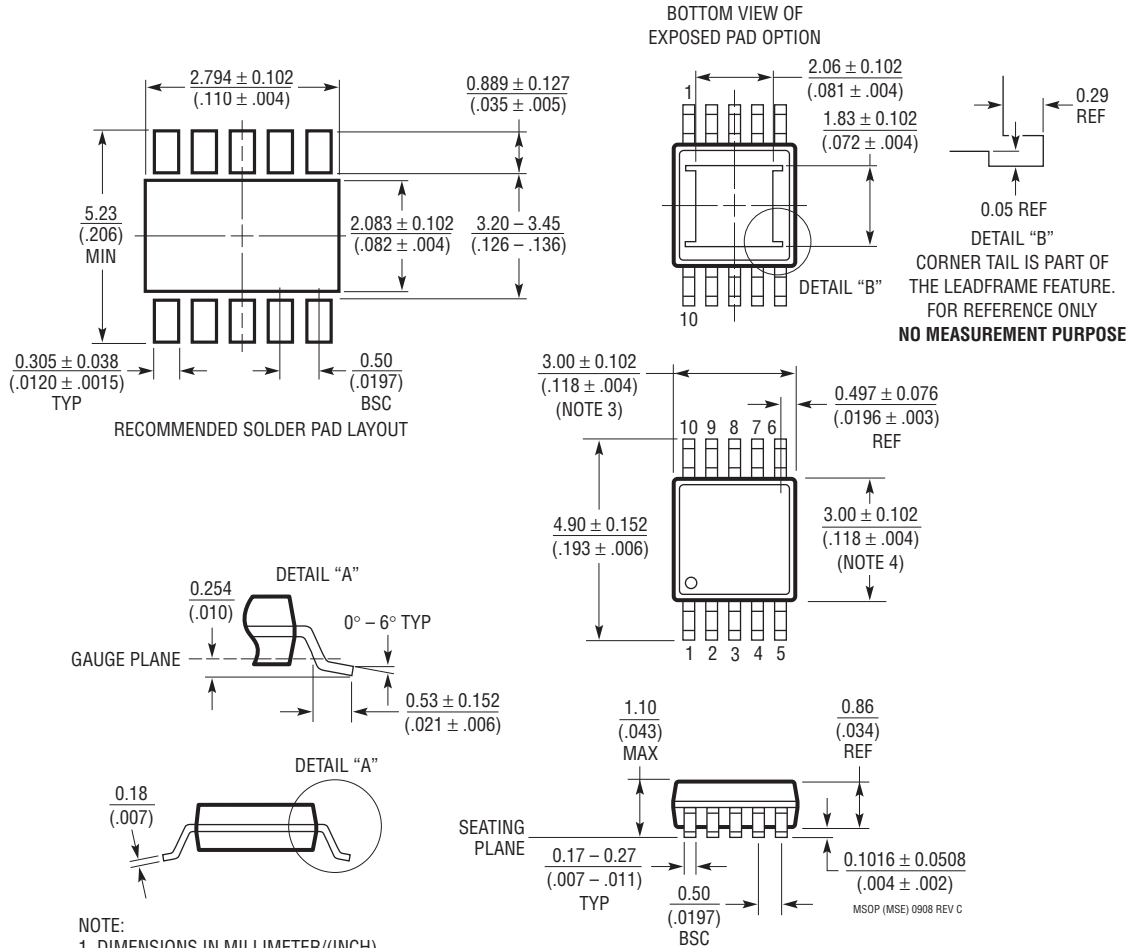

- NOTE:
1. DIMENSIONS IN MILLIMETER/(INCH)
 2. DRAWING NOT TO SCALE
 3. DIMENSION DOES NOT INCLUDE MOLD FLASH, PROTRUSIONS OR GATE BURRS.
MOLD FLASH, PROTRUSIONS OR GATE BURRS SHALL NOT EXCEED 0.152mm (.006") PER SIDE
 4. DIMENSION DOES NOT INCLUDE INTERLEAD FLASH OR PROTRUSIONS.
INTERLEAD FLASH OR PROTRUSIONS SHALL NOT EXCEED 0.152mm (.006") PER SIDE
 5. LEAD COPLANARITY (BOTTOM OF LEADS AFTER FORMING) SHALL BE 0.102mm (.004") MAX