

FEATURES

- **Wide Input Voltage Range: 4.75V to 32V (40V Absolute Maximum)**
- **Programmable Charge Current Up to 2A**
- **User-Selectable Termination: C/10 or Onboard Termination Timer**
- **Dynamic Charge Rate Programming/Soft-Start Pin**
- **Programmable Input Current Limit**
- **No V_{IN} Blocking Diode Required**
- 1MHz Fixed Frequency
- Average Current Mode Control
- 0.5% Float Voltage Accuracy
- 5% Charge Current Accuracy
- 2.5% C/10 Detection Accuracy
- NTC Resistor Temperature Monitor
- Auto-Recharge at 97.5% Float Voltage
- Auto-Precondition at <70% Float Voltage
- Bad-Battery Detection with Auto-Reset
- Binary Coded Open-Collector Status Pins
- 3mm × 3mm DFN-12 or MSOP-12 Package

APPLICATIONS

- Industrial Handheld Instruments
- 12V to 24V Automotive and Heavy Equipment
- Desktop Cradle Chargers
- Notebook Computers

DESCRIPTION

The LT[®]3650 is a complete monolithic single-cell Li-Ion/ Polymer battery charger that operates over a 4.75V to 32V input voltage range (7.5V minimum start-up voltage). The LT3650 provides a constant-current/constant-voltage charge characteristic, with maximum charge current externally programmable up to 2A, set using an external current sense resistor. A precondition feature trickle-charges a low voltage battery, and bad-battery detection provides a signal and suspends charging if a battery does not respond to preconditioning.

The LT3650 can be configured to terminate charging when charge current falls to C/10, or one-tenth the programmed maximum current. Once charging is terminated, the LT3650 enters a low current (85 μ A) standby mode. An auto-restart feature starts a new charging cycle if the battery voltage drops 2.5% from the float voltage, or if a new battery is inserted into a charging system.

The LT3650 contains a user-programmable internal safety timer (typically set to a three hour full cycle time). The IC can be configured to use this internal timer if a time-based termination scheme is desired in which charging can continue below C/10 until a desired time is reached.

The LT3650 is available in a low profile (0.75mm) 3mm × 3mm 12-pin DFN and 12-pin MSOP packages.

LT, LT, LTC, LTM, Linear Technology, PowerPath and the Linear logo are registered trademarks of Linear Technology Corporation. All other trademarks are the property of their respective owners.

TYPICAL APPLICATION

7.5V to 32V Single-Cell Li-Ion 2A Charger

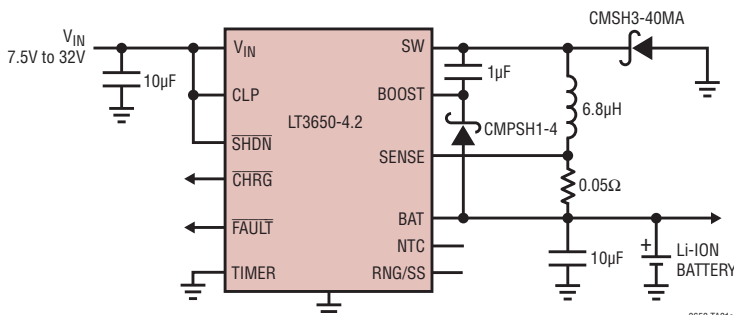

V_{BAT} and Efficiency vs I_{BAT}

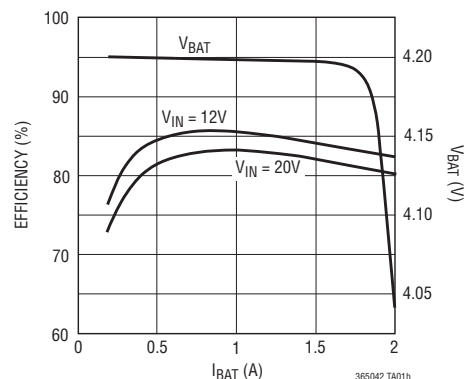

LT3650-4.1/LT3650-4.2

ABSOLUTE MAXIMUM RATINGS (Note 1)

V_{IN}	40V	SENSE-BAT	-0.5V to 0.5V
SHDN, CHRG, FAULT	$V_{IN} + 0.5V$, 40V	TIMER, RNG/SS, NTC	2.5V
CLP	$V_{IN} \pm 0.5V$, 40V	Operating Junction Temperature Range	
SW	40V	(Note 2).....	-40°C to 125°C
SW- V_{IN}	4.5V	Storage Temperature Range	-65°C to 150°C
BOOST	SW + 10V, 50V	Lead Temperature (Soldering, 10 sec)	
SENSE, BAT	10V	MSE.....	300°C

PIN CONFIGURATION



ORDER INFORMATION

LEAD FREE FINISH	TAPE AND REEL	PART MARKING*	PACKAGE DESCRIPTION	TEMPERATURE RANGE
LT3650EDD-4.1#PBF	LT3650EDD-4.1#TRPBF	LFGQ	12-Lead Plastic DFN (3mm x 3mm)	-40°C to 85°C
LT3650IDD-4.1#PBF	LT3650IDD-4.1#TRPBF	LFGQ	12-Lead Plastic DFN (3mm x 3mm)	-40°C to 85°C
LT3650EDD-4.2#PBF	LT3650EDD-4.2#TRPBF	LDDS	12-Lead Plastic DFN (3mm x 3mm)	-40°C to 85°C
LT3650IDD-4.2#PBF	LT3650IDD-4.2#TRPBF	LDDS	12-Lead Plastic DFN (3mm x 3mm)	-40°C to 85°C
LT3650EMSE-4.1#PBF	LT3650EMSE-4.1#TRPBF	365041	12-Lead Plastic MSOP	-40°C to 85°C
LT3650IMSE-4.1#PBF	LT3650IMSE-4.1#TRPBF	365041	12-Lead Plastic MSOP	-40°C to 85°C
LT3650EMSE-4.2#PBF	LT3650EMSE-4.2#TRPBF	365042	12-Lead Plastic MSOP	-40°C to 85°C
LT3650IMSE-4.2#PBF	LT3650IMSE-4.2#TRPBF	365042	12-Lead Plastic MSOP	-40°C to 85°C

Consult LTC Marketing for parts specified with wider operating temperature ranges. *The temperature grade is identified by a label on the shipping container. Consult LTC Marketing for information on nonstandard lead based finish parts.

For more information on lead free part marking, go to: <http://www.linear.com/leadfree/>
For more information on tape and reel specifications, go to: <http://www.linear.com/tapeandreeel/>

ELECTRICAL CHARACTERISTICS The ● denotes the specifications which apply over the full operating temperature range, otherwise specifications are at $V_{IN} = 20V$, $BOOST-SW = 4V$, $SHDN = 2V$, $SENSE = BAT = V_{BAT(FLT)}$, $C_{TIMER} = 0.68\mu F$.

SYMBOL	PARAMETER	CONDITIONS	MIN	TYP	MAX	UNITS
LT3650						
V_{IN}	V_{IN} Operating Range V_{IN} Start Voltage	(Note 3)	● ●	4.75	32 7.5	V V
$V_{IN(OVLO)}$	OVLO Threshold OVLO Hysteresis	V_{IN} Rising	●	32 35 1	40	V V
$V_{IN(UVLO)}$	UVLO Threshold UVLO Hysteresis	V_{IN} Rising	●	4.6 0.2	4.75	V V
$V_{BAT(FLT)}$	Battery Float Voltage	LT3650-4.1	●	4.08 4.06	4.1 4.12 4.14	V V
		LT3650-4.2	●	4.18 4.16	4.2 4.22 4.24	V V
ΔV_{RECHRG}	Recharge Battery Threshold	Threshold Voltage Relative to $V_{BAT(FLT)}$		-100		mV
$V_{BAT(PRE)}$	Battery Precondition Threshold Voltage	V_{BAT} Rising		2.9		V
$V_{BAT(PREHYST)}$	Battery Precondition Threshold Hysteresis			90		mV
I_{VIN}	Operating Input Supply Current	CC/CV Mode, $I_{SW} = 0$ Standby Mode Shutdown ($SHDN = 0$)	●	2.5 85 15	3.5	mA μA μA
I_{BOOST}	BOOST Supply Current	Switch-On, $I_{SW} = 0$ $2.5V < V_{(BOOST-SW)} < 4.5V$		20		mA
I_{BOOST}/I_{SW}	BOOST Switch Drive	$I_{SW} = 2A$		30		mA/A
$V_{SW(ON)}$	Switch-On Voltage Drop	$V_{IN} - V_{SW}$, $I_{SW} = 2A$		350		mV
$I_{SW(MAX)}$	Switch Current Limit		●	2.5		A
$V_{SENSE(PRE)}$	Precondition Current Sense Voltage	$V_{SENSE} - V_{BAT}$ $V_{BAT} = 2.5$		15		mV
$V_{CLP(DC)}$	CLP Threshold Voltage	$V_{CLP} - V_{IN}$; $V_{SENSE} - V_{BAT} = 50mV$	●	37.5	50 62.5	mV
I_{CLP}	CLP Input Bias Current			200		nA
$V_{SENSE(DC)}$	Maximum Current Sense Voltage	$V_{SENSE} - V_{BAT}$; $V_{BAT} = 3.5V$, $V_{RNG/SS} = 1.2V$	●	95	100 105	mV
$V_{SENSE(C/10)}$	C/10 Trigger Sense Voltage		●	7.5	10 12.5	mV
I_{BAT}	BAT Input Bias Current	Charging Terminated	●	0.1	1	μA
I_{SENSE}	SENSE Input Bias Current	Charging Terminated	●	0.1	1	μA
$I_{REVERSE}$	Charger Reverse Current: $I_{BAT} + I_{SENSE} + I_{SW}$	$V_{IN} = 0V$; $BAT = SENSE = SW = V_{BAT(FLT)}$		1		μA
$V_{NTC(H)}$	NTC Range Limit (High)	V_{NTC} Rising	●	1.25	1.36 1.45	V
$V_{NTC(L)}$	NTC Range Limit (Low)	V_{NTC} Falling	●	0.27	0.29 0.315	V
$V_{NTC(HYST)}$	NTC Threshold Hysteresis	% of Threshold		20		%
$R_{NTC(DIS)}$	NTC Disable Impedance	Minimum External Impedance to GND	●	250	500	k Ω
I_{NTC}	NTC Bias Current	$V_{NTC} = 0.8V$	●	47.5	50 52.5	μA
$I_{RNG/SS}$	$I_{RNG/SS}$ Bias Current		●	45	50 55	μA
$V_{RNG/SS}/V_{SENSE}$	Current Limit Programming: $V_{RNG/SS}/V_{SENSE(MAX)}$	$V_{RNG/SS} = 0.5$	●	8.5	10 11.5	V/V
V_{SHDN}	Shutdown Threshold	Rising	●	1.17	1.20 1.23	V
$V_{SHDN(HYST)}$	Shutdown Hysteresis			120		mV
I_{SHDN}	SHDN Input Bias Current			-10		nA

LT3650-4.1/LT3650-4.2

ELECTRICAL CHARACTERISTICS

The ● denotes the specifications which apply over the full operating temperature range, otherwise specifications are at $V_{IN} = 20V$, $BOOST-SW = 4V$, $\overline{SHDN} = 2V$, $SENSE = BAT = V_{BAT(FLT)}$, $C_{TIMER} = 0.68\mu F$.

SYMBOL	PARAMETER	CONDITIONS	MIN	TYP	MAX	UNITS	
V_{CHRG}, V_{FAULT}	Status Low Voltage	10mA Load	●		0.4	V	
I_{TIMER}	Charge/Discharge Current			25		μA	
$V_{TIMER(DIS)}$	Timer Disable Threshold		●	0.1	0.25	V	
t_{TIMER}	Full Charge Cycle Timeout			3		hr	
	Precondition Timeout			22.5		min	
	Timer Accuracy		●	-10	10	%	
f_0	Operating Frequency		●	0.9	1	1.1	MHz
DC	Duty Cycle Range	Continuous Operation	●	15	90	%	

Note 1: Stresses beyond those listed under Absolute Maximum Ratings may cause permanent damage to the device. Exposure to any Absolute Maximum Rating condition for extended periods may affect device reliability and lifetime.

Note 2: The LT3650E is guaranteed to meet performance specifications from 0°C to 85°C. Specifications over the -40°C to 85°C operating

temperature range are assured by design, characterization and correlation with statistical process controls. The LT3650I specifications are guaranteed over the full -40°C to 85°C temperature range. High junction temperatures degrade operating lifetimes.

Note 3: V_{IN} voltages below the start threshold are only supported if $(V_{BOOST} - V_{SW}) > 2V$.

TYPICAL PERFORMANCE CHARACTERISTICS

$T_A = 25^\circ C$, unless otherwise noted.

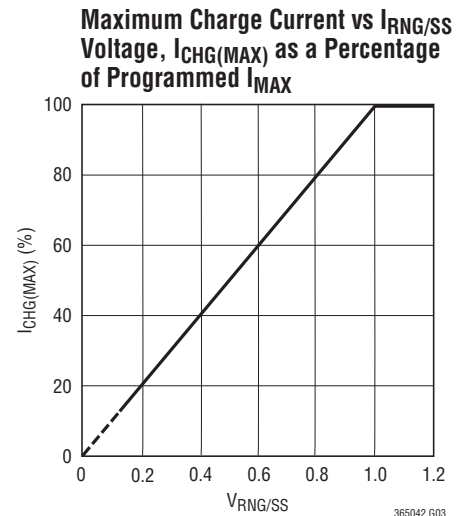
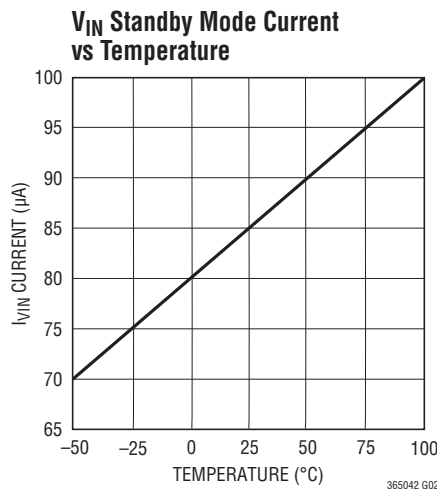
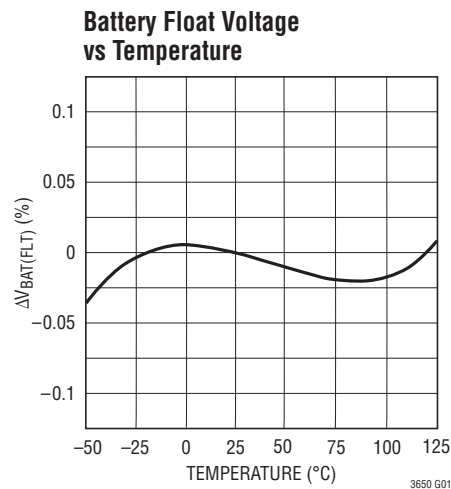

TYPICAL PERFORMANCE CHARACTERISTICS $T_A = 25^\circ\text{C}$, unless otherwise noted.

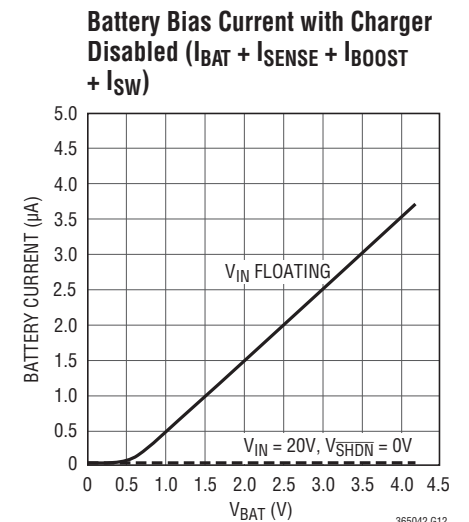
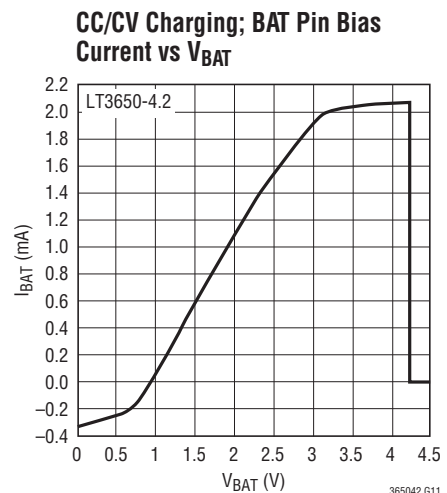
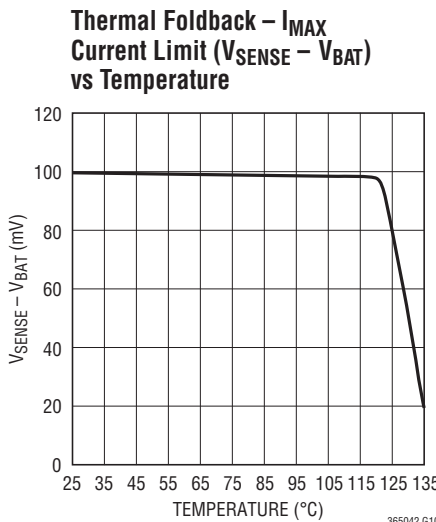
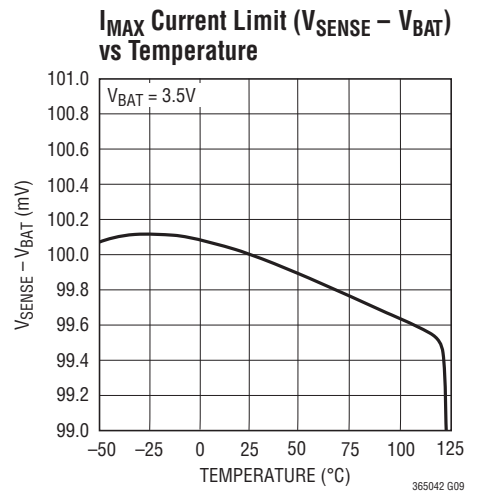
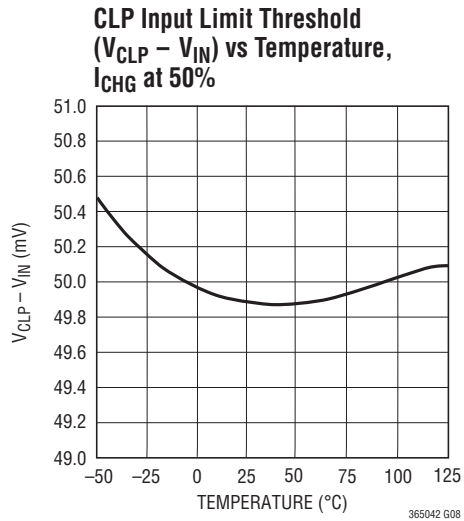
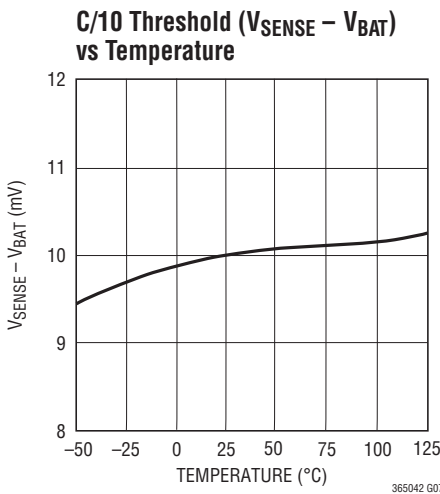
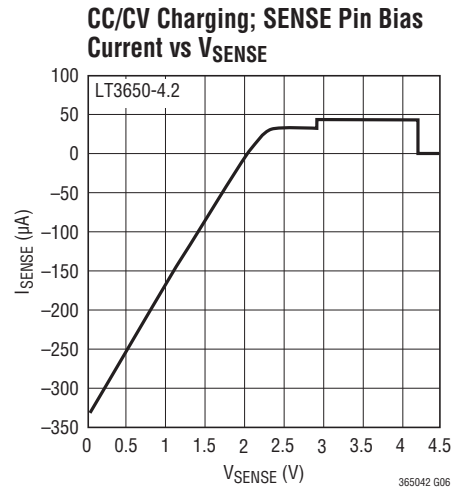
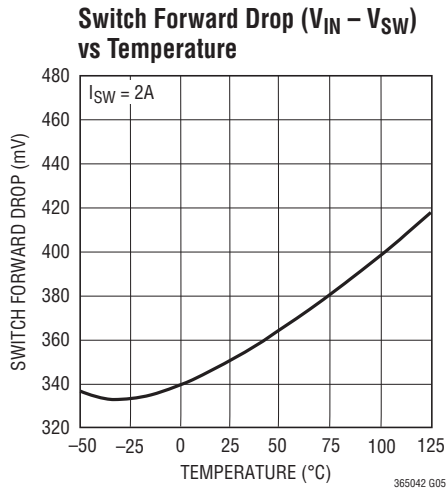
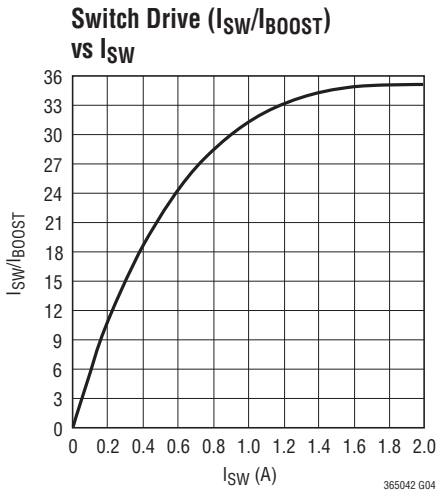

PIN FUNCTIONS

V_{IN} (Pin 1): Charger Input Supply. V_{IN} pin operating range is 4.75V to 32V. V_{IN} ≥ 7.5V or (V_{BOOST} – V_{SW}) > 2V is required for start-up. I_{VIN} = 85μA after charge termination.

CLP (Pin 2): System Current Limit Input. System current levels can be monitored by connecting the input power supply to the CLP pin and connecting a sense resistor from the CLP pin to the V_{IN} pin. Additional system load is drawn from the V_{IN} pin connection, and maximum system load is achieved when V_{CLP} – V_{VIN} = 50mV. The LT3650 servos the maximum charge current required to maintain programmed maximum system current. If this function is not desired, connect the CLP pin to the V_{IN} pin (see the Applications Information section).

SHDN (Pin 3): Precision Threshold Shutdown Pin. The enable threshold is 1.225V (rising), with 120mV of input hysteresis. When in shutdown mode, all charging functions are disabled. The precision threshold allows use of the SHDN pin to incorporate UVLO functions. If the SHDN pin is pulled below 0.4V, the IC enters a low current shutdown mode where the V_{IN} pin current is reduced to 15μA. Typical SHDN pin input bias current is 10nA. If the shutdown function is not desired, connect the pin to the V_{IN} pin.

CHRG (Pin 4): Open-Collector Charger Status Output; typically pulled up through a resistor to a reference voltage. This status pin can be pulled up to voltages as high as V_{IN} when disabled, and can sink currents up to 10mA when enabled. During a battery charging cycle, CHRG is pulled low. When the charge cycle is terminated, the CHRG pin becomes high impedance. If the internal timer is used for termination, the pin stays low during the charging cycle until the charge current drops below a C/10 rate, or I_{CHG(MAX)}/10. A temperature fault also causes this pin to be pulled low (see the Applications Information section).

FAULT (Pin 5): Open-Collector Fault Status Output; typically pulled up through a resistor to a reference voltage. This status pin can be pulled up to voltages as high as V_{IN} when disabled, and can sink currents up to 10mA when enabled. This pin indicates charge cycle fault conditions during a battery charging cycle. A temperature fault causes this pin to be pulled low. If the internal timer is used for termination, a bad-battery fault also causes this pin to

be pulled low. If no fault conditions exist, the FAULT pin remains high impedance (see the Applications Information section).

TIMER (Pin 6): End-Of-Cycle Timer Programming Pin. If a timer-based charge termination is desired, connect a capacitor from this pin to ground. Full charge end-of-cycle time (in hours) is programmed with this capacitor following the equation:

$$t_{EOC} = C_{TIMER} \cdot 4.4 \cdot 10^6$$

A bad-battery fault is generated if the battery does not reach the precondition threshold voltage within one-eighth of t_{EOC}, or:

$$t_{PRE} = C_{TIMER} \cdot 5.5 \cdot 10^5$$

A 0.68μF capacitor is typically used, which generates a timer EOC at three hours, and a precondition limit time of 22.5 minutes. If a timer-based termination is not desired, the timer function is disabled by connecting the TIMER pin to ground. With the timer function disabled, charging terminates when the charge current drops below a C/10 rate, or I_{CHG(MAX)}/10.

RNG/SS (Pin 7): Charge Current Programming Pin. This pin allows a dynamic adjustment of the maximum charge current, and can be used to employ a soft-start function. Maximum charge current is adjusted by setting the voltage on this pin, such that the maximum desired voltage across the inductor current sense resistor (V_{SENSE} – V_{BAT}) is 0.1 • V_{RNG/SS}, so the maximum charge current reduces to:

$$V_{RNG/SS} \cdot I_{CHG(MAX)}$$

This pin has an effective range from 0V to 1V. 50μA is sourced from this pin, so the maximum charge current can be programmed by connecting a resistor (R_{RNG/SS}) from RNG/SS to ground, such that the voltage dropped across the resistor is equivalent to the desired programming voltage, or:

$$V_{RNG/SS} = 50\mu A \cdot R_{RNG/SS}$$

Soft-start functionality can be implemented by connecting a capacitor (C_{RNG/SS}) from RNG/SS to ground, such that the time required to charge the capacitor to 1V

PIN FUNCTIONS

(full charge current) is the desired soft-start interval (t_{SS}). For no $R_{RNG/SS}$, this capacitor value follows the relation:

$$C_{RNG/SS} = 50\mu A \cdot t_{SS}$$

The RNG/SS pin is pulled low during fault conditions, allowing graceful recovery from faults should soft-start functionality be implemented. Both the soft-start capacitor and the programming resistor can be implemented in parallel. All C/10 monitoring functions are disabled while $V_{RNG/SS}$ is below 0.1V to accommodate long soft-start intervals.

RNG/SS voltage can also be manipulated using an active device, employing a pull-down transistor to disable charge current or to dynamically servo maximum charge current. Manipulation of the RNG/SS pin with active devices that have low impedance pull-up capability is not allowed (see the Applications Information section).

NTC (Pin 8): Battery Temperature Monitor Pin. This pin is the input to the NTC (negative temperature coefficient) thermistor temperature monitoring circuit. This function is enabled by connecting a 10k Ω , B = 3380 NTC thermistor from the NTC pin to ground. The pin sources 50 μ A, and monitors the voltage across the 10k Ω thermistor. When the voltage on this pin is above 1.36V ($T < 0^{\circ}\text{C}$) or below 0.29V ($T > 40^{\circ}\text{C}$), charging is disabled and the $\overline{\text{CHRG}}$ and $\overline{\text{FAULT}}$ pins are both pulled low. If internal timer termination is being used, the timer is paused, suspending the charging cycle. Charging resumes when the voltage on NTC returns to within the 0.29V to 1.36V active region. There is approximately 5 $^{\circ}\text{C}$ of temperature hysteresis associated with each of the temperature thresholds. The temperature monitoring function remains enabled while thermistor resistance to ground is less than 250k Ω , so if this function is not desired, leave the NTC pin unconnected.

BAT (Pin 9): Battery Voltage Monitor Pin. Connect 10 μ F decoupling capacitance (C_{BAT}) from this pin to ground. Depending on application requirements, larger value decoupling capacitors may be required (see the Application Information section). The charge function operates to achieve the final float voltage at this pin. The auto-restart feature initiates a new charging cycle when the voltage at

the BAT pin falls 2.5% below this float voltage. Once the charge cycle is terminated, the input bias current of the BAT pin is reduced to <0.1 μ A, to minimize battery discharge while the charger remains connected.

SENSE (Pin 10): Charge Current Sense Pin. Connect the more positive voltage end of the inductor sense resistor (R_{SENSE}) to the SENSE pin and the other end to the BAT pin. The voltage across this resistor sets the average charge current. The maximum average charge current (I_{MAX}) corresponds to 100mV across the sense resistor. This resistor can be set to program maximum charge currents as high as 2A. The sense resistor value follows the relation:

$$R_{SENSE} = \frac{0.1V}{I_{MAX}}$$

Once the charge cycle is terminated, the input bias current of the SENSE pin is reduced to <0.1 μ A, to minimize battery discharge while the charger remains connected.

BOOST (Pin 11): Bootstrapped Supply Rail for Switch Drive. This pin facilitates saturation of the switch transistor. Connect a 1 μ F or greater capacitor from the BOOST pin to the SW pin. Operating range of this pin is 0V to 4.5V, referenced to the SW pin. The voltage on the decoupling capacitor is refreshed through a rectifying diode, with the anode connected to either the battery output voltage or an external source, and the cathode connected to the BOOST pin.

SW (Pin 12): Switch Output Pin. This pin is the output of the charger switch, and corresponds to the emitter of the switch transistor. When enabled, the switch shorts the SW pin to the V_{IN} supply. The drive circuitry for this switch is bootstrapped above the V_{IN} supply using the BOOST supply pin, allowing saturation of the switch for maximum efficiency. The effective on-resistance of the boosted switch is 0.175 Ω .

SGND (Pin 13): Ground Reference and Backside Exposed Lead Frame Thermal Connection. Solder the exposed lead frame to the PCB ground plane.

BLOCK DIAGRAM

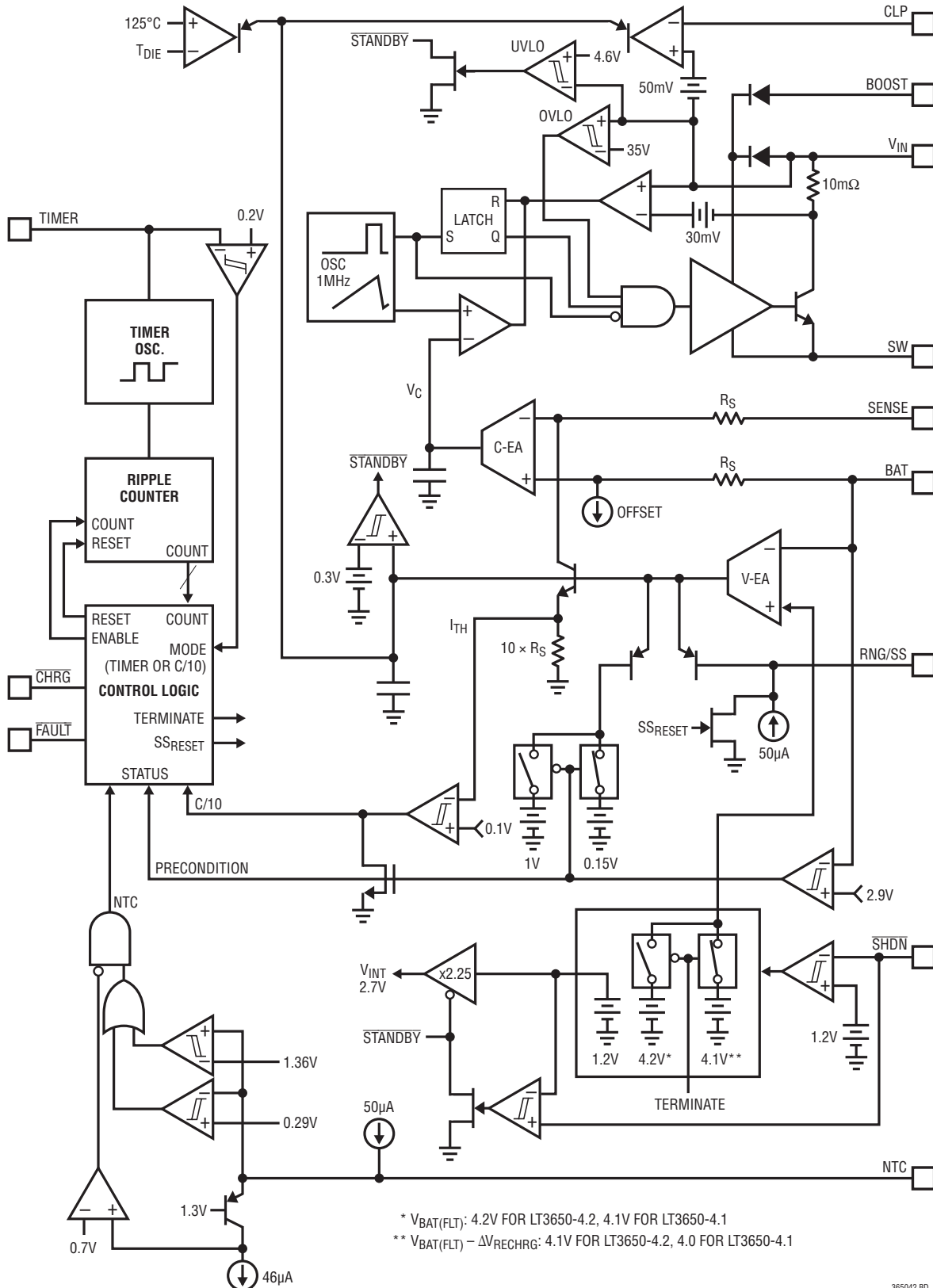

365042 BD

OPERATION

OVERVIEW

LT3650 is a complete monolithic, mid-power, Li-Ion battery charger, addressing high input voltage applications with solutions that use a minimum of external components. The IC uses a 1MHz constant-frequency, average current mode step-down architecture. Internal reverse-voltage protection allows direct connection to the input supply without a blocking diode.

The LT3650 incorporates a 2A switch that is driven by a bootstrapped supply to maximize efficiency during charging cycles. A wide input range allows the operation to full charge from $5V \pm 5\%$ to 32V. A precision threshold shutdown pin allows incorporation of UVLO functionality using a simple resistor divider. The IC can also be put into a low current shutdown mode, in which the input supply bias is reduced to only $15\mu A$.

The LT3650 incorporates several degrees of charge current control freedom. The overall maximum charge current is set using an external inductor current sense resistor. A maximum charge current programming pin allows dynamic manipulation of the battery charge current. The LT3650 also incorporates a system input supply current limit control feature that servos the battery charge current to accommodate overall system load requirements.

The LT3650 automatically enters a battery precondition mode if the sensed battery voltage is very low. In this mode, the charge current is reduced to 15% of the programmed maximum, as set by the inductor sense resistor, R_{SENSE} . Once the battery voltage climbs above the internally set precondition threshold of 2.9V, the IC automatically increases the maximum charge current to the full programmed value.

The LT3650 can use a charge current based C/10 termination scheme, which ends a charge cycle when the battery charge current falls to one-tenth the programmed maximum charge current. The LT3650 also contains an internal charge cycle control timer, for timer-based termination. When using the internal timer, the IC combines C/10 detection with a programmable time constraint, during which the charging cycle can continue beyond the C/10 level to *top-off* a battery. The charge cycle terminates when a specific time elapses, typically three hours. When the

timer-based scheme is used, the IC also supports bad-battery detection, which triggers a system fault if a battery stays in precondition mode for more than one-eighth of the total programmed charge cycle time.

Once charging is terminated and the LT3650 is not actively charging, the IC automatically enters a low current standby mode in which supply bias currents are reduced to $85\mu A$. If the battery voltage drops 2.5% from the full charge float voltage, the LT3650 engages an automatic charge cycle restart. The IC also automatically restarts a new charge cycle after a bad-battery fault once the failed battery is removed and replaced with another battery.

The LT3650 contains provisions for a battery temperature monitoring circuit. This feature monitors battery temperature by using a thermistor during the charging cycle, suspends charging, and signals a fault condition if the battery temperature moves outside a safe charging range.

The LT3650 contains two digital open-collector outputs, which provide charger status and signal fault conditions. These binary coded pins signal battery charging, standby or shutdown modes, battery temperature faults and bad-battery faults.

General Operation (See Block Diagram)

The LT3650 uses average current mode control architecture, such that the IC servos directly to average charge current. The LT3650 senses charger output voltage via the BAT pin. The difference between the voltage on this pin and an internal float voltage reference is integrated by the voltage error amplifier (V-EA). This amplifier generates an error voltage on its output (I_{TH}), which corresponds to the average current sensed across the inductor current sense resistor, R_{SENSE} , which is connected between the SENSE and BAT pins. The I_{TH} voltage is then divided down by a factor of 10, and imposed on the input of the current error amplifier (C-EA). The difference between this imposed voltage and the current sense resistor voltage is integrated, with the resulting voltage (V_C) used as a threshold that is compared against an internally generated ramp. The output of this comparison controls the charger's switch.

OPERATION

The I_{TH} error voltage corresponds linearly to average current sensed across the inductor current sense resistor, allowing maximum charge current control by limiting the effective voltage range of I_{TH} . A clamp limits this voltage to 1V which, in turn, limits the current sense voltage to 100mV. This sets the maximum charge current, or the current delivered while the charger is operating in constant-current (CC) mode, which corresponds to 100mV across R_{SENSE} . This maximum charge current level can also be manipulated through the RNG/SS pin (see the RNG/SS: Dynamic Charge Current Adjust and RNG/SS: Soft-Start sections).

If the voltage on the BAT pin is below $V_{BAT(PRE)}$, the LT3650 engages precondition mode. During the precondition interval, the charger continues to operate in constant-current mode, but the maximum charge current is reduced to 15% of the maximum programmed value as set by R_{SENSE} .

When the charger output voltage on the BAT pin approaches the float voltage ($V_{BAT(FLT)}$), the charger transitions into constant-voltage (CV) mode, and charge current is reduced from the maximum value. As this occurs, the I_{TH} voltage falls from the limit clamp and servos to lower voltages. The IC monitors the I_{TH} voltage as it is reduced, and detection of the C/10 charge current is achieved when $I_{TH} = 0.1V$. If the charger is configured for C/10 termination, this threshold is used to terminate the charge cycle. Once the charge cycle is terminated, the \overline{CHRG} status pin becomes high impedance and the charger enters low current standby mode.

The LT3650 contains an internal charge cycle timer that terminates a successful charge cycle after a programmed amount of time. This timer is typically programmed to achieve end-of-cycle (EOC) in three hours, but can be configured for any amount of time by setting an appropriate

timing capacitor value (C_{TIMER}). When timer termination is used, the charge cycle does not terminate after C/10 is achieved. Because the \overline{CHRG} status pin responds to the C/10 current level, the IC will indicate a fully charged battery status, but the charger will continue to source low currents into the battery until the programmed EOC time has elapsed, at which time the charge cycle will terminate. At EOC, when the charging cycle terminates, if the battery did not achieve at least 97.5% of the full float voltage, charging is deemed unsuccessful. The LT3650 will then re-initiate, and charging will continue for another full timer cycle.

Use of the timer function also enables bad-battery detection. This fault condition is achieved if the battery does not respond to preconditioning and the charger remains in (or enters) precondition mode after one-eighth of the programmed charge cycle time. A bad-battery fault halts the charging cycle, the \overline{CHRG} status pin goes high impedance and the \overline{FAULT} pin is pulled low.

When the LT3650 terminates a charging cycle, whether through C/10 detection or by reaching timer EOC, the average current mode analog loop remains active but the internal float voltage reference is reduced by 2.5%. Because the voltage on a successfully charged battery is at the full float voltage, the voltage error amp detects an overvoltage condition and rails low. When the voltage error amp output drops below 0.3V, the IC enters standby mode, where most of the internal circuitry is disabled, and the V_{IN} bias current is reduced to 85 μ A. When the voltage on the BAT pin drops below the reduced float reference level, the output of the voltage error amp will climb, at which point the IC comes out of standby mode and a new charging cycle is initiated.

APPLICATIONS INFORMATION

V_{IN} Input Supply

The LT3650 is biased directly from the charger input supply through the V_{IN} pin. This supply provides large switched currents, so a high quality, low ESR decoupling capacitor is recommended to minimize voltage glitches on V_{IN} . The V_{IN} decoupling capacitor (C_{VIN}) absorbs all input switching ripple current in the charger, so it must have an adequate ripple current rating. RMS ripple current ($I_{CVIN(RMS)}$) is:

$$I_{CVIN(RMS)} \sim I_{CHG(MAX)} \cdot \left(\frac{V_{BAT}}{V_{IN}} \right) \cdot \left(\left[\frac{V_{IN}}{V_{BAT}} \right] - 1 \right)^{\frac{1}{2}}$$

which has a maximum at $V_{IN} = 2 \cdot V_{BAT}$, where:

$$I_{CVIN(RMS)} = I_{CHG(MAX)}/2$$

The simple worst-case of $1/2 \cdot I_{CHG(MAX)}$ is commonly used for design.

Bulk capacitance is a function of desired input ripple voltage (ΔV_{IN}), and follows the relation:

$$C_{IN(BULK)} = I_{MAX} \cdot \left(\frac{V_{BAT} / V_{IN}}{\Delta V_{IN}} \right) (\mu F)$$

10 μ F is typically adequate for most charger applications.

BOOST Supply

The BOOST bootstrapped supply rail drives the internal switch and facilitates saturation of switch transistor. Operating range of the BOOST pin is 0V to 4.5V, as referenced to the SW pin. Connect a 1 μ F or greater capacitor from the BOOST pin to the SW pin.

The voltage on the decoupling capacitor is refreshed through a diode, with the anode connected to/from either the battery output voltage or an external source, and the cathode connected to the BOOST pin. Rate the diode average current greater than 0.1A, and its reverse voltages greater than $V_{IN(MAX)}$.

V_{IN} /BOOST Start-Up Requirement

The LT3650 operates with a V_{IN} range of 4.75V to 32V, however, a start-up voltage requirement exists due to the nature of the nonsynchronous step-down switcher topology used for the charger. If there is no BOOST supply available, the internal switch requires $(V_{IN} - V_{SW}) > 3V$ to operate. This requirement does not exist if the BOOST supply is available and $(V_{BOOST} - V_{SW}) > 2V$.

When an LT3650 charger is not switching, the SW pin is at the same potential as the battery, which can be as high as $V_{BAT(FLT)}$. For reliable start-up, the V_{IN} supply must be at least 3V above the SW pin. The minimum start-up specification of V_{IN} at or above 7.5V provides ample margin to satisfy this requirement. Once switching begins, the BOOST supply capacitor gets charged such that $(V_{BOOST} - V_{SW}) > 2V$, and the V_{IN} requirement no longer applies.

In low V_{IN} applications, the BOOST supply can be powered by an external source for start-up, eliminating the V_{IN} start-up requirement.

V_{BAT} Output Decoupling

An LT3650 charger output requires bypass capacitance connected from the BAT pin to ground (C_{BAT}). A 10 μ F ceramic capacitor is required for all applications. In systems where the battery can be disconnected from the charger output, additional bypass capacitance may be desired for visual indication of a no-battery condition (see the Status Pins section).

If it is desired to operate a system load from the LT3650 charger output when the battery is disconnected, additional bypass capacitance is required. In this type of application with the charger being used as a DC/DC converter, excessive ripple and/or low amplitude oscillations can occur without additional output bulk capacitance. For these applications, place a 100 μ F low ESR nonceramic capacitor (chip tantalum or organic semiconductor capacitors such as Sanyo OS-CONs or POSCAPs) from BAT to ground, in parallel with the 10 μ F ceramic bypass capacitor. This additional bypass capacitance may also be required in systems where the battery is connected to the charger through long wires. The voltage rating on C_{BAT} must meet or exceed the battery float voltage.

APPLICATIONS INFORMATION

R_{SENSE}: Charge Current Programming

The LT3650 charger is configurable to charge at average currents as high as 2A. Maximum charge current is set by choosing an inductor sense resistor such that the desired maximum average current through that sense resistor creates a 100mV drop, or:

$$R_{SENSE} = \frac{0.1}{I_{MAX(AVG)}}$$

where $I_{MAX(AVG)}$ is the maximum average charge current. A 2A charger, for example, would use a 0.05Ω sense resistor.

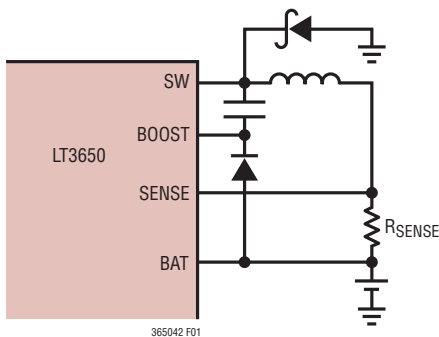

Figure 1. Programming Maximum Charge Current Using R_{SENSE}

Inductor Selection

The primary criteria for inductor value selection in an LT3650 charger is the ripple current created in that inductor. Once the inductance value is determined, an inductor must also have a saturation current equal to or exceeding the maximum peak current in the inductor. An inductor value (L), given the desired amount of ripple current (ΔI_{MAX}) can be approximated using the relation:

$$L = \left(\frac{10}{\Delta I_{MAX}} \right) \cdot R_{SENSE} \cdot (V_{BAT} + V_F) \cdot \left(1 - \left[\frac{V_{BAT} + V_F}{V_{IN(MAX)} + V_F} \right] \right) (\mu H)$$

In the previous relation, ΔI_{MAX} is the normalized ripple current, $V_{IN(MAX)}$ as the maximum operational voltage, and V_F is the forward voltage of the rectifying Schottky diode. Ripple current is typically set within a range of 25%

to 35% of I_{MAX} , so an inductor value can be determined by setting $0.25 < \Delta I_{MAX} < 0.35$.

Magnetics vendors typically specify inductors with maximum RMS and saturation current ratings. Select an inductor that has a saturation current rating at or above $(1 + \Delta I_{MAX}/2) \cdot I_{MAX}$, and an RMS rating above I_{MAX} . Inductors must also meet a maximum volt-second product requirement. If this specification is not in the data sheet of an inductor, consult the vendor to make sure the maximum volt-second product is not being exceeded by your design. The minimum required volt-second product is:

$$V_{BAT} \cdot \left(1 - \frac{V_{BAT}}{V_{IN(MAX)}} \right) (V \cdot \mu s)$$

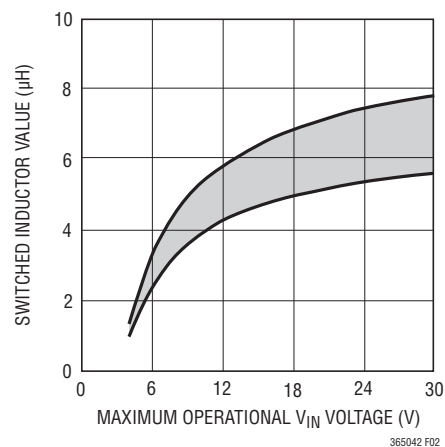

Figure 2. 2A Charger Switched Inductor Value (R_{SENSE} = 0.05Ω) 25% to 35% I_{MAX} Ripple Current

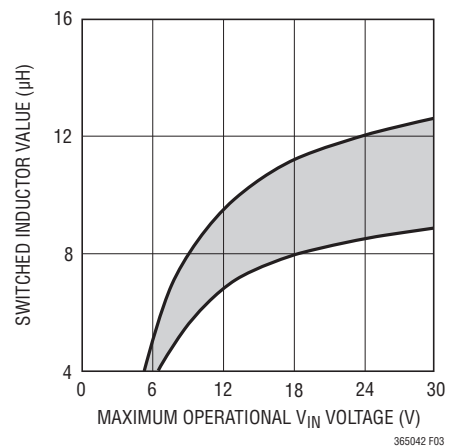

Figure 3. 1.3A Charger Switched Inductor Value (R_{SENSE} = 0.075Ω) 25% to 35% I_{MAX} Ripple Current

APPLICATIONS INFORMATION

Rectifier Selection

The rectifier diode in an LT3650 battery charger provides a current path for the inductor current when the main power switch is disabled. The rectifier is selected based upon forward voltage, reverse voltage, and maximum current. A Schottky diode is required, as low forward voltage yields the lowest power loss and highest efficiency. The rectifier diode must be rated to withstand reverse voltages greater than the maximum V_{IN} voltage.

The minimum average diode current rating ($I_{DIODE(MAX)}$) is calculated with maximum output current (I_{MAX}), maximum operational V_{IN} , and output at the precondition threshold ($V_{BAT(PRE)}$):

$$I_{DIODE(MAX)} > \frac{I_{MAX} \cdot (V_{IN(MAX)} - V_{BAT(PRE)})}{V_{IN(MAX)}} \quad (A)$$

For example, a rectifier diode for a 4.2V, 1.5A charger with a 20V maximum input voltage would require:

$$I_{DIODE(MAX)} > \frac{1.5 \cdot (20 - 2.9)}{20}, \text{ or:}$$

$$I_{DIODE(MAX)} > 1.3A$$

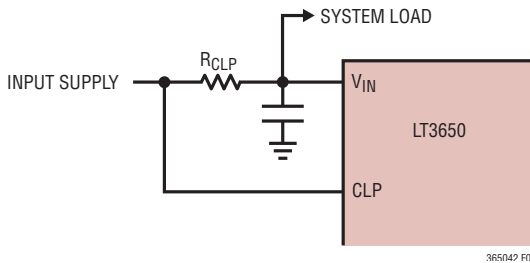

Figure 4. R_{CLP} Sets the Input Supply Current Limit

CLP: System Current Limit

The LT3650 contains a PowerPath™ control feature to support multiple load systems. The charger adjusts output current in response to a system load if overall input supply current exceeds the programmed maximum value.

Maximum input supply current is set by choosing a sense resistor (R_{CLP}) such that the desired maximum current through that sense resistor creates a 50mV drop, or:

$$R_{CLP} = \frac{0.05}{I_{MAX(IN)}}$$

where $I_{MAX(IN)}$ is the maximum input current. A 1.5A system limit, for example, would use a 33mΩ sense resistor.

The LT3650 integrates the CLP signal internally, so average current limiting is performed in most cases without the need for external filter elements.

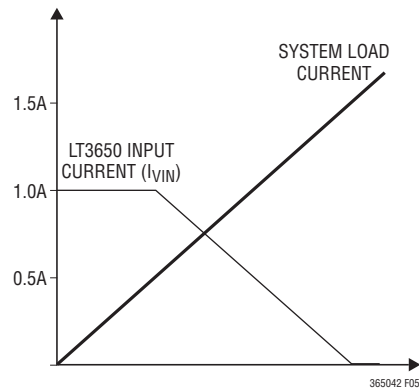

Figure 5. CLP Limit: Charger Current vs System Load Current with 1.5A Limit

APPLICATIONS INFORMATION

RNG/SS: Dynamic Charge Current Adjust

The LT3650 gives the user the capability to adjust maximum charge current dynamically through the RNG/SS pin. The voltage on the RNG/SS pin corresponds to ten times the maximum voltage across the sense resistor (R_{SENSE}). The default maximum sense voltage is 100mV, so maximum charge current can be expressed as:

$$I_{MAX(RNG/SS)} = I_{MAX} \cdot V_{RNG/SS}$$

where $I_{MAX(RNG/SS)}$ is the maximum charge current if $V_{RNG/SS}$ is within 0V to 1V. Voltages higher than 1V have no effect on the maximum charge current.

The LT3650 sources 50µA from the RNG/SS pin, such that a current control voltage can be set by simply connecting an appropriately valued resistor to ground, following the relation:

$$R_{RNG/SS} = \frac{V_{RNG/SS}}{50\mu A}$$

For example, to reduce the maximum charge current to 50% of the original value, which corresponds to a maximum sense voltage of 50mV, RNG/SS would be set to 0.5V.

$$R_{RNG/SS} = \frac{0.5V}{50\mu A} = 10k\Omega$$

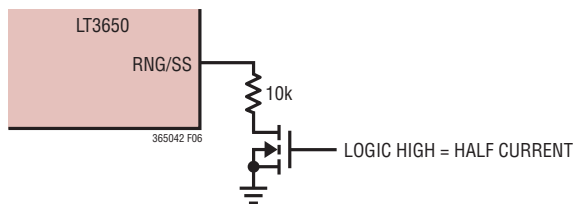

Figure 6. Using the RNG/SS Pin for Digital Control of Maximum Charge Current

This feature could be used, for example, to switch in a reduced charge current level. Active servos can also be used to impose voltages on the RNG/SS pin, provided they can only sink current. Active circuits that source current cannot be used to drive the RNG/SS pin. Resistive pull-ups can be used, but extreme care must be taken not to exceed the 2.5V absolute maximum voltage on the pin.

RNG/SS: Soft-Start

Soft-start functionality is also supported by the RNG/SS pin. 50µA is sourced from the RNG/SS pin, so connecting a capacitor from the RNG/SS pin to ground ($C_{RNG/SS}$) creates a linear voltage ramp. The maximum charge current follows this voltage. Thus, the charge current increases from zero to the fully programmed value as the capacitor charges from 0V to 1V. The value of $C_{RNG/SS}$ is calculated based on the desired time to full current (t_{SS}) following the relation:

$$C_{RNG/SS} = 50\mu A \cdot t_{SS}$$

The RNG/SS pin is pulled to ground internally when charging is terminated so each new charging cycle begins with a soft-start cycle. RNG/SS is also pulled to ground during bad-battery and NTC fault conditions, so a graceful recovery from these faults is possible.

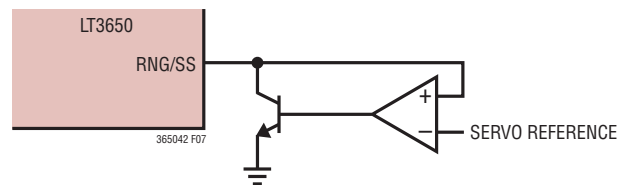

Figure 7. Driving the RNG/SS Pin with a Current-Sink Active Servo Amplifier

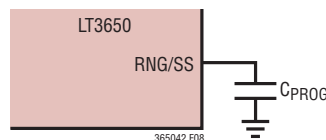

Figure 8. Using the RNG/SS Pin for Soft-Start

APPLICATIONS INFORMATION

Status Pins

The LT3650 reports charger status through two open-collector outputs, the $\overline{\text{CHRG}}$ and $\overline{\text{FAULT}}$ pins. These pins can accept voltages as high as V_{IN} , and can sink up to 10mA when enabled.

The $\overline{\text{CHRG}}$ pin indicates that the charger is delivering current at greater than a C/10 rate, or one-tenth of the programmed maximum charge current. The $\overline{\text{FAULT}}$ pin signals bad-battery and NTC faults. These pins are binary coded, and signal following the table below, where On indicates the pin pulled low, and Off indicates pin high impedance:

Table 1. Status Pins State Table

STATUS PINS STATE		CHARGER STATUS
$\overline{\text{CHRG}}$	$\overline{\text{FAULT}}$	
Off	Off	Not Charging—Standby or Shutdown Mode
Off	On	Bad-Battery Fault (Precondition Timeout/EOC Failure)
On	Off	Normal Charging at C/10 or Greater
On	On	NTC Fault (Pause)

If the battery is removed from an LT3650 charger that is configured for C/10 termination, a sawtooth waveform of approximately 100mV appears at the charger output, due to cycling between termination and recharge events. This cycling results in pulsing at the $\overline{\text{CHRG}}$ output. An LED connected to this pin will exhibit a blinking pattern, indicating to the user that a battery is not present. The frequency of this blinking pattern is dependent on the output capacitance.

C/10 Termination

The LT3650 supports a low current based termination scheme, where a battery charge cycle terminates when the current output from the charger falls to below one-tenth the maximum current, as programmed with R_{SENSE} . The C/10 threshold current corresponds to 10mV across R_{SENSE} . This termination mode is engaged by shorting the TIMER pin to ground.

When C/10 termination is used, an LT3650 charger sources battery charge current as long as the average current level remains above the C/10 threshold. As the full-charge float

voltage is achieved, the charge current falls until the C/10 threshold is reached, at which time the charger terminates and the LT3650 enters standby mode. The $\overline{\text{CHRG}}$ status pin follows the charger cycle and is high impedance when the charger is not actively charging.

When V_{BAT} drops below 97.5% of the full-charged float voltage, whether by battery loading or replacement of the battery, the charger automatically re-engages and starts charging.

There is no provision for bad-battery detection if C/10 termination is used.

Timer Termination

The LT3650 supports a timer-based termination scheme, in which a battery charge cycle is terminated after a specific amount of time elapses. Timer termination is engaged when a capacitor (C_{TIMER}) is connected from the TIMER pin to ground. The timer cycle EOC (t_{EOC}) occurs based on C_{TIMER} following the relation:

$$C_{\text{TIMER}} = t_{\text{EOC}} \cdot 2.27 \cdot 10^{-7} \text{ (Hours)}$$

Timer EOC is typically set to three hours, which requires a 0.68 μF capacitor.

The $\overline{\text{CHRG}}$ status pin continues to signal charging at a C/10 rate, regardless of which termination scheme is used. When timer termination is used, the $\overline{\text{CHRG}}$ status pin is pulled low during a charging cycle until the charger output current falls below the C/10 threshold. The charger continues to *top off* the battery until timer EOC, when the LT3650 terminates the charging cycle and enters standby mode.

Termination at the end of the timer cycle only occurs if the charging cycle was successful. A successful charge cycle occurs when the battery is charged to within 2.5% of the full-charge float voltage. If a charge cycle is not successful at EOC, the timer cycle resets and charging continues for another full timer cycle.

When V_{BAT} drops below 97.5% of the full-charge float voltage, whether by battery loading or replacement of the battery, the charger automatically re-engages and starts charging.

APPLICATIONS INFORMATION

Preconditioning and Bad-Battery Fault

An LT3650 charger has a precondition mode, in which charge current is limited to 15% of the programmed I_{MAX} , as set by R_{SENSE} . The precondition current corresponds to 15mV across R_{SENSE} .

Precondition mode is engaged while the voltage on the BAT pin is below the precondition threshold ($V_{BAT(PRE)}$). Once the BAT voltage rises above the precondition threshold, normal full-current charging can commence. The LT3650 incorporates 3% of threshold hysteresis to prevent mode glitching.

When the internal timer is used for termination, bad-battery detection is engaged. This fault detection feature is designed to identify failed cells. A bad-battery fault is triggered when the voltage on BAT remains below the precondition threshold for greater than one-eighth of a full timer cycle (one-eighth EOC). A bad-battery fault is also triggered if a normally charging battery re-enters precondition mode after one-eighth EOC.

When a bad-battery fault is triggered, the charging cycle is suspended, so the \overline{CHRG} status pin becomes high impedance. The \overline{FAULT} pin is pulled low to signal a fault detection. The RNG/SS pin is also pulled low during this fault, to accommodate a graceful restart, in the event that a soft-start function is incorporated (see the RNG/SS : Soft-Start section).

Cycling the charger's power or \overline{SHDN} function initiates a new charging cycle, but an LT3650 charger does not require a reset. Once a bad-battery fault is detected, a new timer charging cycle initiates when the BAT pin exceeds the precondition threshold voltage. During a bad-battery fault, 0.5mA is sourced from the charger; removing the failed battery allows the charger output voltage to rise and initiate a charge cycle reset. As such, removing a bad battery resets the LT3650, so a new charging cycle is started by connecting another battery to the charger output.

Battery Temperature Fault: NTC

The LT3650 can accommodate battery temperature monitoring by using an NTC (negative temperature coefficient) thermistor close to the battery pack. The temperature monitoring function is enabled by connecting a 10k Ω , B = 3380 NTC thermistor from the NTC pin to ground. If the NTC function is not desired, leave the pin unconnected.

The NTC pin sources 50 μ A, and monitors the voltage dropped across the 10k Ω thermistor. When the voltage on this pin is above 1.36V (0 $^{\circ}$ C) or below 0.29V (40 $^{\circ}$ C), the battery temperature is out of range, and the LT3650 triggers an NTC fault. The NTC fault condition remains until the voltage on the NTC pin corresponds to a temperature within the 0 $^{\circ}$ C to 40 $^{\circ}$ C range. Both hot and cold thresholds incorporate hysteresis that corresponds to 5 $^{\circ}$ C.

If higher operational charging temperatures are desired, the temperature range can be expanded by adding series resistance to the 10k NTC resistor. Adding a 0.91k resistor will increase the effective temperature threshold to 45 $^{\circ}$ C.

During an NTC fault, charging is halted and both status pins are pulled low. If timer termination is enabled, the timer count is suspended and held until the fault condition is relieved. The RNG/SS pin is also pulled low during this fault, to accommodate a graceful restart in the event that a soft-start function is being incorporated (see the RNG/SS : Soft-Start section).

Thermal Foldback

The LT3650 contains a thermal foldback protection feature that reduces maximum charger output current if the IC junction temperature approaches 125 $^{\circ}$ C. In most cases, on-chip temperatures servo such that any overtemperature conditions are relieved with only slight reductions in maximum charger current.

In some cases, the thermal foldback protection feature can reduce charger currents below the C/10 threshold. In applications that use C/10 termination (TIMER = 0V), the LT3650 will suspend charging and enter standby mode until the overtemperature condition is relieved.

APPLICATIONS INFORMATION

Layout Considerations

The LT3650 switch node has rise and fall times that are typically less than 10ns to maximize conversion efficiency. The switched node (Pin SW) trace should be kept as short as possible to minimize high frequency noise. The input capacitor (C_{IN}) should be placed close to the IC to minimize this switching noise. Short, wide traces on these nodes also help to avoid voltage stress from inductive ringing. The BOOST decoupling capacitor should also be in close proximity to the IC to minimize inductive ringing. The SENSE and BAT traces should be routed together and kept as short as possible. Shielding these signals from switching noise with ground is recommended.

High current paths and transients should be kept isolated from battery ground, to assure an accurate output voltage reference. Effective grounding can be achieved by considering switched current in the ground plane,

and careful component placement and orientation can effectively steer these high currents such that the battery reference does not get corrupted. Figure 9 illustrates an effective grounding scheme using component placement to control ground currents. When the switch is enabled (loop #1), current flows from the input bypass capacitor (C_{IN}) through the switch and inductor to the battery positive terminal. When the switch is disabled (loop #2), the current to the battery positive terminal is provided from ground through the freewheeling Schottky diode (D_F). In both cases, these switched currents return to ground via the output bypass capacitor (C_{BAT}).

The LT3650 packaging has been designed to efficiently remove heat from the IC via the exposed pad on the backside of the package, which is soldered to a copper footprint on the PCB. This footprint should be made as large as possible to reduce the thermal resistance of the IC case to ambient air.

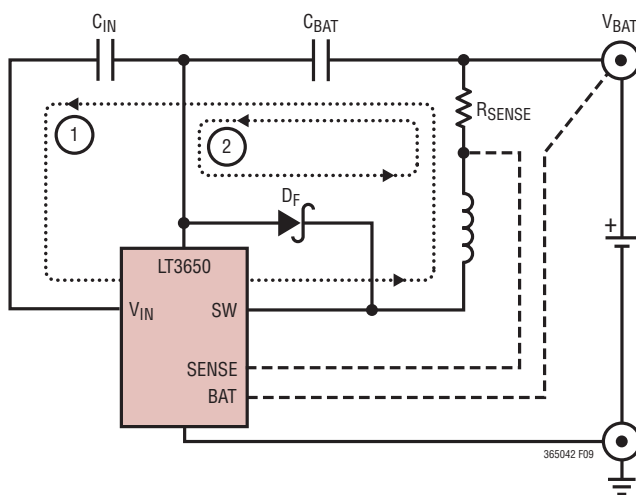
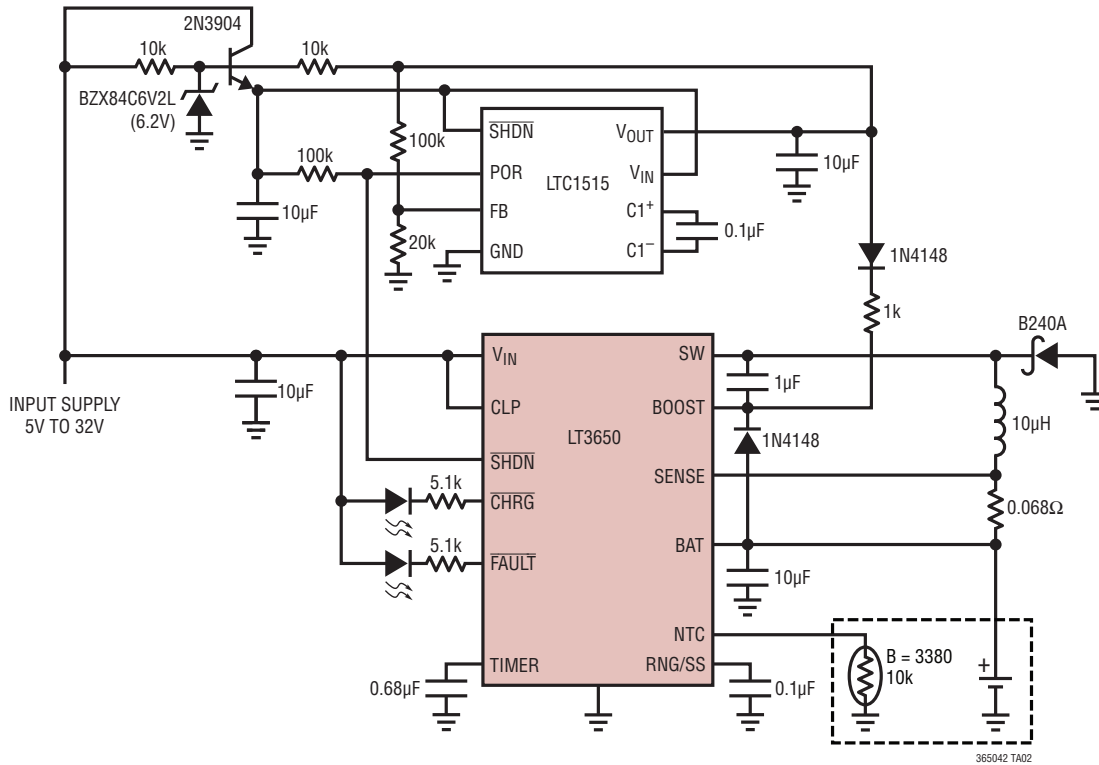

Figure 9. Component Orientation Isolates High Current Paths From Sensitive Nodes

TYPICAL APPLICATIONS

5V to 32V 1.5A Charger with Three Hour EOC Termination. The LTC1515 Provides Boost Start-Up Requirement. Status Pins Use LED Indicators



12V to 32V 2A Charger with Three Hour EOC Termination and Removable Battery Pack. The RNG/SS Pin Is Used to Reduce the Maximum Charger Current if $12V < V_{IN} < 20V$; Input UVLO = 10V. NTC Range Is Extended to +45C. The Charger Can Supply Loads Up to the Maximum Charger Current with No Battery Connected

**RNG/SS Pin Foldback:
 $I_{CHG(MAX)}$ vs V_{IN}**

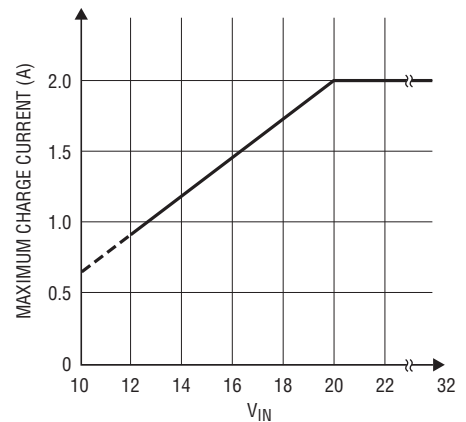
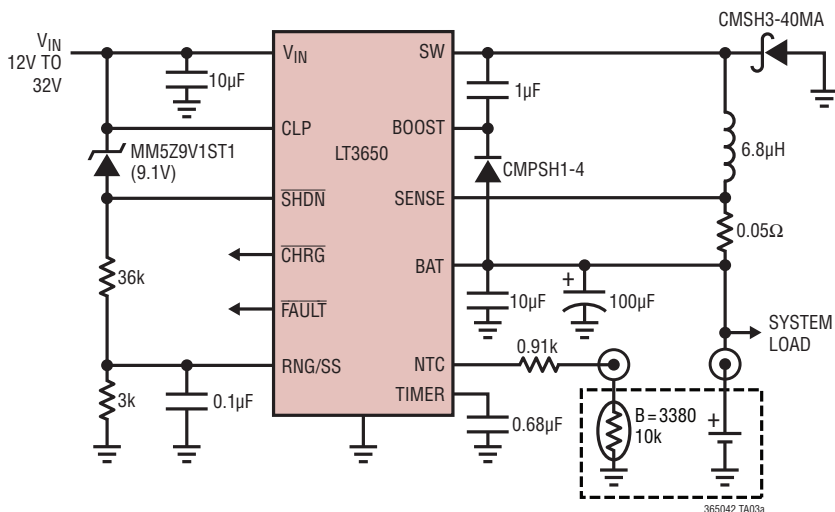

PACKAGE DESCRIPTION

Please refer to <http://www.linear.com/designtools/packaging/> for the most recent package drawings.

DD Package 12-Lead Plastic DFN (3mm × 3mm) (Reference LTC DWG # 05-08-1725 Rev A)

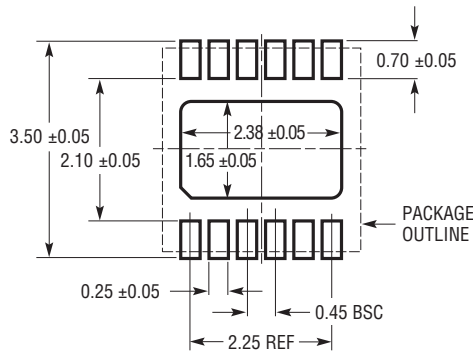

RECOMMENDED SOLDER PAD PITCH AND DIMENSIONS
APPLY SOLDER MASK TO AREAS THAT ARE NOT SOLDERED

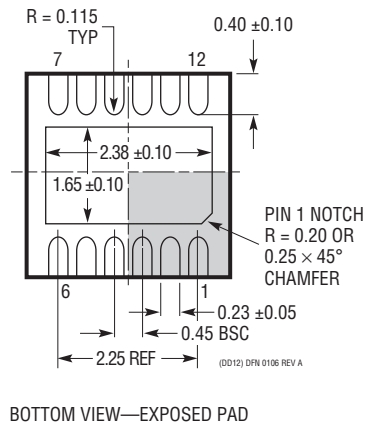
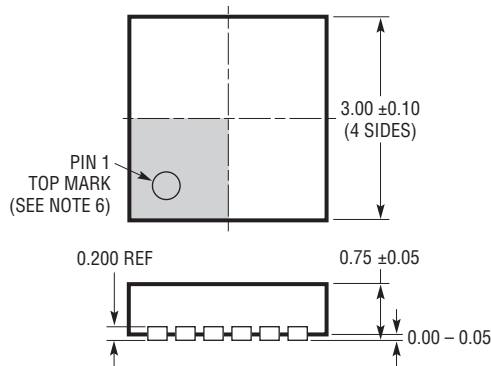

- NOTE:
1. DRAWING IS NOT A JEDEC PACKAGE OUTLINE
 2. DRAWING NOT TO SCALE
 3. ALL DIMENSIONS ARE IN MILLIMETERS
 4. DIMENSIONS OF EXPOSED PAD ON BOTTOM OF PACKAGE DO NOT INCLUDE MOLD FLASH. MOLD FLASH, IF PRESENT, SHALL NOT EXCEED 0.15mm ON ANY SIDE
 5. EXPOSED PAD AND TIE BARS SHALL BE SOLDER PLATED
 6. SHADED AREA IS ONLY A REFERENCE FOR PIN 1 LOCATION ON THE TOP AND BOTTOM OF PACKAGE

PACKAGE DESCRIPTION

Please refer to <http://www.linear.com/designtools/packaging/> for the most recent package drawings.

MSE Package 12-Lead Plastic MSOP, Exposed Die Pad (Reference LTC DWG # 05-08-1666 Rev F)

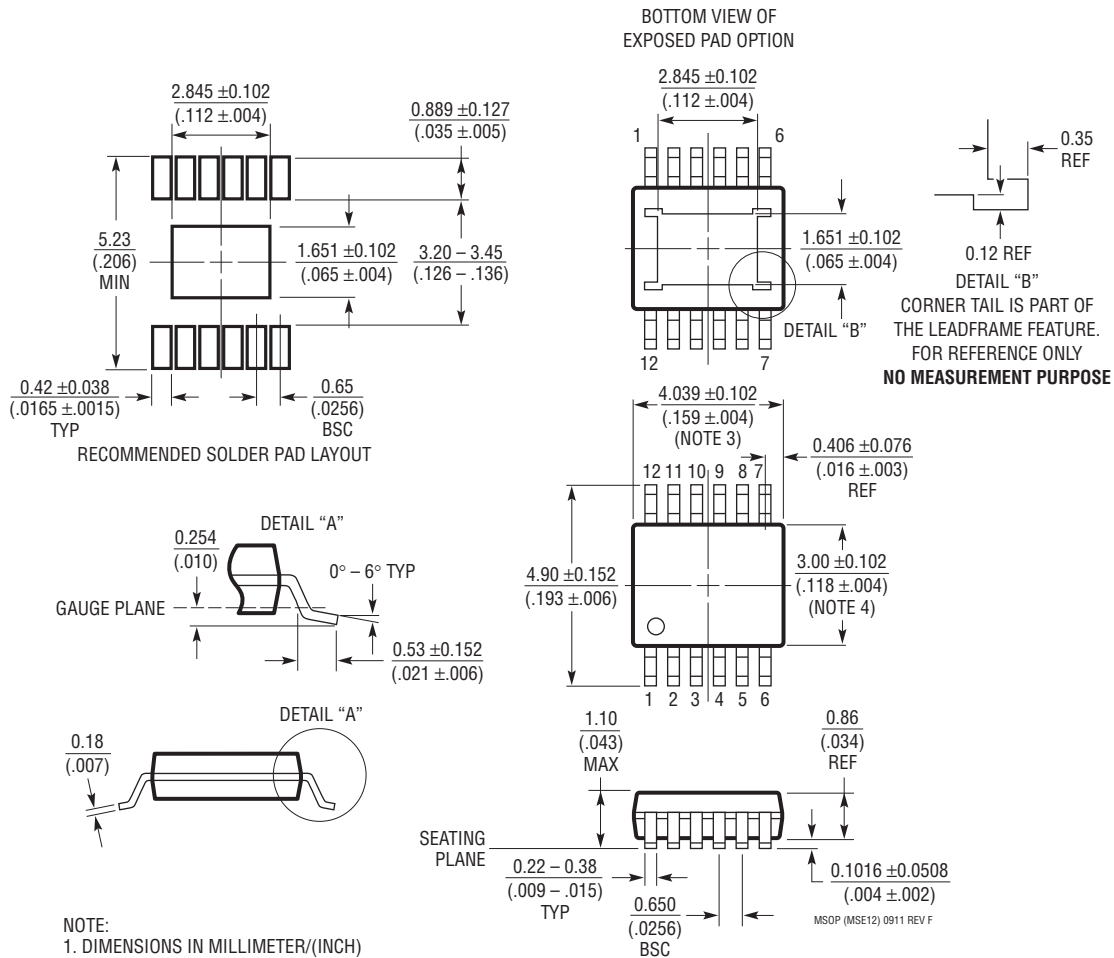

NOTE:

1. DIMENSIONS IN MILLIMETER/(INCH)
2. DRAWING NOT TO SCALE
3. DIMENSION DOES NOT INCLUDE MOLD FLASH, PROTRUSIONS OR GATE BURRS. MOLD FLASH, PROTRUSIONS OR GATE BURRS SHALL NOT EXCEED 0.152mm (.006") PER SIDE
4. DIMENSION DOES NOT INCLUDE INTERLEAD FLASH OR PROTRUSIONS. INTERLEAD FLASH OR PROTRUSIONS SHALL NOT EXCEED 0.152mm (.006") PER SIDE
5. LEAD COPLANARITY (BOTTOM OF LEADS AFTER FORMING) SHALL BE 0.102mm (.004") MAX
6. EXPOSED PAD DIMENSION DOES INCLUDE MOLD FLASH. MOLD FLASH ON E-PAD SHALL NOT EXCEED 0.254mm (.010") PER SIDE.

REVISION HISTORY (Revision history begins at Rev C)

REV	DATE	DESCRIPTION	PAGE NUMBER
C	12/12	Added new Battery Bias Current curve	5