

# Single 5V RS232/RS485 Multiprotocol Transceiver

## FEATURES

- Two RS232 Transceivers or One RS485 Transceiver
- Operates from a Single 5V Supply
- Guaranteed Receiver Output with Inputs Floating or Shorted to Ground
- Logic Selectable Fast/Slow RS485 Driver Slew Rate
- Low Supply Current: 7mA Typical
- 5 $\mu$ A Supply Current in Shutdown
- Self-Testing Capability in Loopback Mode
- Separate Driver and Receiver Enable Controls
- Driver Maintains High Impedance in Three-State, Shutdown or with Power Off
- Receiver Inputs Can Withstand  $\pm 25$ V

## APPLICATIONS

- Point-of-Sale Terminals
- Software Selectable Multiprotocol Interface Ports
- Low Power RS485/RS422/RS232/EIA562 Interface
- Cable Repeaters
- Level Translators

## DESCRIPTION

The LTC<sup>®</sup>1387 is a low power reconfigurable CMOS bi-directional transceiver. It can be configured as an RS485 differential port or as two RS232 single-ended ports. An onboard charge pump uses four 0.1 $\mu$ F capacitors to generate boosted positive and negative supplies, allowing the RS232 drivers to meet  $\pm 5$ V output swing requirements with only a single 5V supply. A shutdown mode reduces the I<sub>CC</sub> supply current to 5 $\mu$ A.

The RS232 transceivers are in full compliance with RS232 specification. The RS485 transceiver is in full compliance with RS485 and RS422 specifications. The RS485 receiver assumes a known output state when the inputs are floating or shorted to ground. All interface drivers feature short-circuit and thermal shutdown protection. An enable pin allows RS485 driver outputs to be forced into high impedance which is maintained even when the outputs are forced beyond supply rails or the power is off. A loop back mode allows the driver outputs to be connected back to the receiver inputs for diagnostic self-test.

The LTC1387 is available in 20-pin plastic SSOP and SW packages.

 LTC and LT are registered trademarks of Linear Technology Corporation.

## TYPICAL APPLICATION

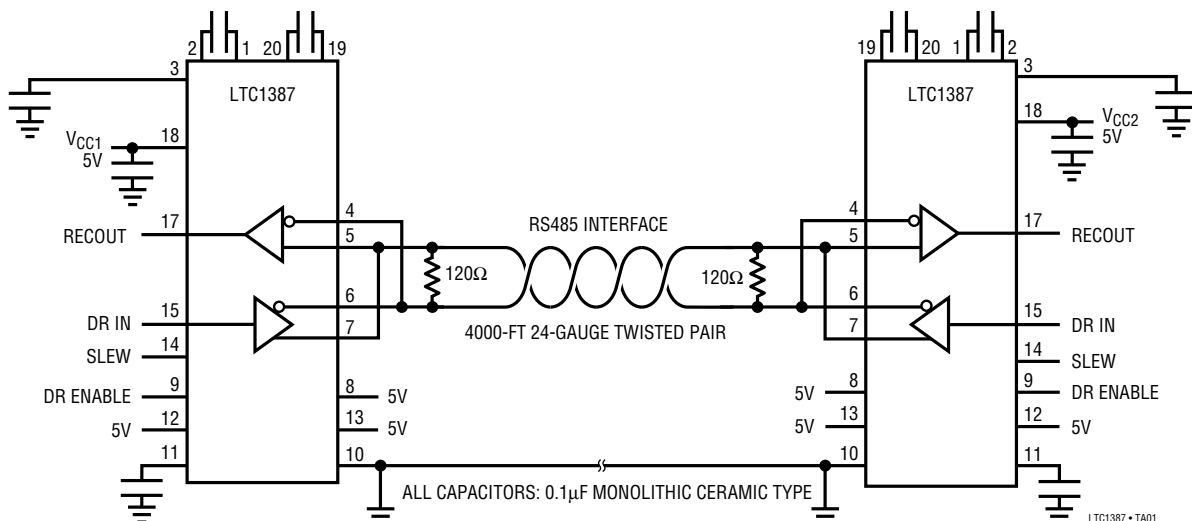

LTC1387 • TA01

## ABSOLUTE MAXIMUM RATINGS

(Note 1)

Supply Voltage ( $V_{CC}$ ) .....	6.5V
Input Voltage	
Drivers .....	-0.3V to ( $V_{CC} + 0.3V$ )
Receivers .....	-25V to 25V
485/232, ON, DXEN	
RXEN, SLEW .....	-0.3V to ( $V_{CC} + 0.3V$ )
Output Voltage	
Drivers .....	-18V to 18V
Receivers .....	-0.3V to ( $V_{CC} + 0.3V$ )
Short-Circuit Duration	
Output .....	Indefinite
$V_{DD}$ , $V_{EE}$ , $C1^+$ , $C1^-$ , $C2^+$ , $C2^-$ .....	30 sec
Operating Temperature Range	
LTC1387C .....	0°C to 70°C
LTC1387I .....	-40°C to 85°C
Storage Temperature Range .....	-65°C to 150°C
Lead Temperature (Soldering, 10 sec) .....	300°C

## PACKAGE/ORDER INFORMATION

TOP VIEW

G PACKAGE      SW PACKAGE  
20-LEAD PLASTIC SSOP      20-LEAD PLASTIC SO

$T_{JMAX} = 125^{\circ}C, \theta_{JA} = 120^{\circ}C/W (G)$   
 $T_{JMAX} = 125^{\circ}C, \theta_{JA} = 75^{\circ}C/W (SW)$

ORDER PART NUMBER

LTC1387CG  
LTC1387CSW  
LTC1387IG  
LTC1387ISW

Consult factory for Military grade parts.

## DC ELECTRICAL CHARACTERISTICS

$T_A = 25^{\circ}C$ ,  $V_{CC} = 5V$ ,  $C1 = C2 = C3 = C4 = 0.1\mu F$  (Notes 2, 3), unless otherwise noted.

SYMBOL	PARAMETER	CONDITIONS	MIN	TYP	MAX	UNITS
<b>RS485 Driver (485/232 = High, ON = DXEN = High)</b>						
$V_{OD1}$	Differential Driver Output Voltage (Unloaded)	$I_O = 0$	●		6	V
$V_{OD2}$	Differential Driver Output Voltage (With Load)	Figure 1, $R = 50\Omega$ (RS422) Figure 1, $R = 27\Omega$ (RS485)	●	2.0	6	V
$\Delta V_{OD}$	Change in Magnitude of Driver Differential Output Voltage for Complementary Output States	Figure 1, $R = 27\Omega$ or $R = 50\Omega$	●		0.2	V
$V_{OC}$	Driver Common Mode Output Voltage	Figure 1, $R = 27\Omega$ or $R = 50\Omega$	●		3	V
$\Delta  V_{OC} $	Change in Magnitude of Driver Common Mode Output Voltage for Complementary Output States	Figure 1, $R = 27\Omega$ or $R = 50\Omega$	●		0.2	V
$I_{OSD}$	Driver Short-Circuit Current	$V_O = -7V, 12V; V_O = \text{High}$ $V_O = -7V, 12V; V_O = \text{Low}$ (Note 4)	●	35	250	mA
$I_{OZD}$	Three-State Output Current (Y, Z)	$-7V \leq V_O \leq 12V$		±5	500	µA
<b>RS232 Driver (485/232 = Low, ON = DXEN = High)</b>						
$V_O$	Output Voltage Swing	Figure 4, $R_L = 3k$ , Positive Figure 4, $R_L = 3k$ , Negative	●	5	6.5	V
$I_{OSD}$	Output Short-Circuit Current	$V_O = 0V$	●	±17	±60	mA
<b>Driver Inputs and Control Inputs</b>						
$V_{IH}$	Input High Voltage	$D_Y, D_Z, DXEN, RXEN, ON, 485/232, SLEW$	●	2		V
$V_{IL}$	Input Low Voltage	$D_Y, D_Z, DXEN, RXEN, ON, 485/232, SLEW$	●		0.8	V
$I_{IN}$	Input Current	$D_Y, D_Z, DXEN, RXEN, ON, 485/232, SLEW$ (Note 5)	●	±0.1	±10	µA
			●	5	15	µA

**DC ELECTRICAL CHARACTERISTICS**

$T_A = 25^\circ\text{C}$ ,  $V_{CC} = 5\text{V}$ ,  $C_1 = C_2 = C_3 = C_4 = 0.1\mu\text{F}$  (Notes 2, 3), unless otherwise noted.

SYMBOL	PARAMETER	CONDITIONS	MIN	TYP	MAX	UNITS
<b>RS485 Receiver (485/232 = High, ON = RXEN = High)</b>						
$V_{TH}$	Differential Input Threshold Voltage	$-7\text{V} \leq V_{CM} \leq 12\text{V}$	●	-0.20	0.20	V
$\Delta V_{TH}$	Input Hysteresis	$V_{CM} = 0\text{V}$		40		mV
$I_{IN}$	Input Current (A, B)	$V_{IN} = 12\text{V}$ $V_{IN} = -7\text{V}$	● ●	-0.8	1	mA mA
$R_{IN}$	Input Resistance	$-7\text{V} \leq V_{IN} \leq 12\text{V}$	●	12	24	k $\Omega$
<b>RS232 Receiver (485/232 = Low, ON = RXEN = High)</b>						
$V_{TH}$	Receiver Input Voltage Threshold	Input Low Threshold Input High Threshold	● ●	0.8	2.4	V V
$\Delta V_{TH}$	Receiver Input Hysteresis			0.6		V
$R_{IN}$	Receiver Input Resistance	$V_{IN} = \pm 10\text{V}$		3	5	7 k $\Omega$
<b>Receiver Output (ON = RXEN = High)</b>						
$V_{OH}$	Receiver Output High Voltage	$I_O = -3\text{mA}$ , $V_{IN} = 0\text{V}$ , 485/232 = Low	●	3.5	4.6	V
$V_{OL}$	Receiver Output Low Voltage	$I_O = 3\text{mA}$ , $V_{IN} = 3\text{V}$ , 485/232 = Low	●		0.2	0.4 V
$I_{OSR}$	Short-Circuit Current	$0\text{V} \leq V_O \leq V_{CC}$	●	7	85	mA
$I_{OZR}$	Three-State Output Current	$RXEN = 0\text{V}$	●		$\pm 0.1$	$\pm 10$ $\mu\text{A}$
<b>Power Supply Generator</b>						
$V_{DD}$	$V_{DD}$ Output Voltage	No Load, ON = DXEN = RXEN = High $I_{DD} = -5\text{mA}$ , ON = DXEN = RXEN = High		8 7		V V
$V_{EE}$	$V_{EE}$ Output Voltage	No Load, ON = DXEN = RXEN = High $I_{EE} = 5\text{mA}$ , ON = DXEN = RXEN = High		-7.7 -7.0		V V
<b>Power Supply</b>						
$I_{CC}$	$V_{CC}$ Supply Current	No Load, ON = DXEN = RXEN = High Shutdown, ON = DXEN = RXEN = 0V	● ●	7 5	25 100	mA $\mu\text{A}$

**AC ELECTRICAL CHARACTERISTICS**

$T_A = 25^\circ\text{C}$ ,  $V_{CC} = 5\text{V}$ ,  $C_1 = C_2 = C_3 = C_4 = 0.1\mu\text{F}$  (Notes 2, 3), unless otherwise noted.

SYMBOL	PARAMETER	CONDITIONS	MIN	TYP	MAX	UNITS
<b>RS232 Mode (ON = DXEN = RXEN = High, 485/232 = Low)</b>						
SR	Slew Rate	Figure 4, $R_L = 3\text{k}$ , $C_L = 15\text{pF}$ Figure 4, $R_L = 3\text{k}$ , $C_L = 1000\text{pF}$	● ●		30	V/ $\mu\text{s}$ V/ $\mu\text{s}$
$t_T$	Transition Time	Figure 4, $R_L = 3\text{k}$ , $C_L = 2500\text{pF}$	●	0.22	1.9	3.1 $\mu\text{s}$
$t_{PLH}$	Driver Input to Output	Figures 4, 10, $R_L = 3\text{k}$ , $C_L = 15\text{pF}$	●	0.6	4	$\mu\text{s}$
$t_{PHL}$	Driver Input to Output	Figures 4, 10, $R_L = 3\text{k}$ , $C_L = 15\text{pF}$	●	0.6	4	$\mu\text{s}$
$t_{PLH}$	Receiver Input to Output	Figures 5, 11	●	0.3	6	$\mu\text{s}$
$t_{PHL}$	Receiver Input to Output	Figures 5, 11	●	0.4	6	$\mu\text{s}$
<b>RS485 Mode (Fast Slew Rate, ON = DXEN = High, 485/232 = High, SLEW = High)</b>						
$t_{PLH}$	Driver Input to Output	Figures 2, 7, $R_L = 54\Omega$ , $C_L = 100\text{pF}$	●	15	40	70 ns
$t_{PHL}$	Driver Input to Output	Figures 2, 7, $R_L = 54\Omega$ , $C_L = 100\text{pF}$	●	15	40	70 ns
$t_{SKEW}$	Driver Output to Output	Figures 2, 7, $R_L = 54\Omega$ , $C_L = 100\text{pF}$	●	5	15	ns
$t_r, t_f$	Driver Rise or Fall Time	Figures 2, 7, $R_L = 54\Omega$ , $C_L = 100\text{pF}$	●	3	15	40 ns

## AC ELECTRICAL CHARACTERISTICS

$T_A = 25^\circ\text{C}$ ,  $V_{CC} = 5\text{V}$ ,  $C_1 = C_2 = C_3 = C_4 = 0.1\mu\text{F}$  (Notes 2, 3), unless otherwise noted.

SYMBOL	PARAMETER	CONDITIONS		MIN	TYP	MAX	UNITS
<b>RS485 Mode (Fast Slew Rate, ON = DXEN = High, 485/232 = High, SLEW = High)</b>							
$t_{ZL}$	Driver Enable to Output Low	Figures 3, 8, $C_L = 100\text{pF}$ , S1 Closed	●		50	90	ns
$t_{ZH}$	Driver Enable to Output High	Figures 3, 8, $C_L = 100\text{pF}$ , S2 Closed	●		50	90	ns
$t_{LZ}$	Driver Disable from Low	Figures 3, 8, $C_L = 15\text{pF}$ , S1 Closed	●		50	90	ns
$t_{HZ}$	Driver Disable from High	Figures 3, 8, $C_L = 15\text{pF}$ , S2 Closed	●		60	90	ns
<b>RS485 Mode (Slow Slew Rate, ON = DXEN = High, 485/232 = High, SLEW = Low)</b>							
$t_{PLH}$	Driver Input to Output	Figures 2, 7, $R_L = 54\Omega$ , $C_L = 100\text{pF}$	●	100	700	1500	ns
$t_{PHL}$	Driver Input to Output	Figures 2, 7, $R_L = 54\Omega$ , $C_L = 100\text{pF}$	●	100	700	1500	ns
$t_{SKEW}$	Driver Output to Output	Figures 2, 7, $R_L = 54\Omega$ , $C_L = 100\text{pF}$	●		200	750	ns
$t_r, t_f$	Driver Rise or Fall Time	Figures 2, 7, $R_L = 54\Omega$ , $C_L = 100\text{pF}$	●	150	300	1500	ns
$t_{ZL}$	Driver Enable to Output Low	Figures 3, 8, $C_L = 100\text{pF}$ , S1 Closed	●		600	1500	ns
$t_{ZH}$	Driver Enable to Output High	Figures 3, 8, $C_L = 100\text{pF}$ , S2 Closed	●		600	1500	ns
$t_{LZ}$	Driver Disable from Low	Figures 3, 8, $C_L = 15\text{pF}$ , S1 Closed	●		100	200	ns
$t_{HZ}$	Driver Disable from High	Figures 3, 8, $C_L = 15\text{pF}$ , S2 Closed	●		100	200	ns
<b>RS485 Mode (ON = RXEN = High, 485/232 = High)</b>							
$t_{PLH}$	Receiver Input to Output	Figures 2, 9, $R_L = 54\Omega$ , $C_L = 100\text{pF}$	●	20	70	140	ns
$t_{PHL}$	Receiver Input to Output	Figures 2, 9, $R_L = 54\Omega$ , $C_L = 100\text{pF}$	●	20	70	140	ns
$t_{SKEW}$	Differential Receiver Skew, $ t_{PLH} - t_{PHL} $	Figures 2, 9, $R_L = 54\Omega$ , $C_L = 100\text{pF}$			10		ns
<b>Receiver Output Enable/Disable (ON = High)</b>							
$t_{ZL}$	Receiver Enable to Output Low	Figures 6, 12, $C_L = 15\text{pF}$ , S1 Closed	●		40	90	ns
$t_{ZH}$	Receiver Enable to Output High	Figures 6, 12, $C_L = 15\text{pF}$ , S2 Closed	●		40	90	ns
$t_{LZ}$	Receiver Disable from Low	Figures 6, 12, $C_L = 15\text{pF}$ , S1 Closed	●		40	90	ns
$t_{HZ}$	Receiver Disable from High	Figures 6, 12, $C_L = 15\text{pF}$ , S2 Closed	●		40	90	ns

The ● denotes specifications which apply over the full operating temperature range.

**Note 1:** Absolute Maximum Ratings are those values beyond which the life of the device may be impaired.

**Note 2:** All currents into device pins are positive; all currents out of device pins are negative. All voltages are referenced to device ground unless otherwise specified.

**Note 3:** All typicals are given at  $V_{CC} = 5\text{V}$ ,  $C_1 = C_2 = C_3 = C_4 = 0.1\mu\text{F}$  and  $T_A = 25^\circ\text{C}$ .

**Note 4:** Short-circuit current for RS485 driver output low state folds back above  $V_{CC}$ . Peak current occurs around  $V_O = 3\text{V}$ .

**Note 5:** SLEW includes an internal pull-up in RS485 mode.

## PIN FUNCTIONS

**C1+ (Pin 1):** Commutating Capacitor C1 Positive Terminal. Requires an external  $0.1\mu\text{F}$  capacitor between Pins 1 and 2.

**C1- (Pin 2):** Commutating Capacitor C1 Negative Terminal.

**$V_{DD}$  (Pin 3):** Charge Pump Positive Supply Output. Requires an external  $0.1\mu\text{F}$  capacitor to ground.

**A (Pin 4):** Receiver Input A. Inverting input of RS232 receiver A in RS232 mode; inverting RS485 receiver input in RS485 mode.

**B (Pin 5):** Receiver Input B. Inverting input of RS232 receiver B in RS232 mode; noninverting RS485 receiver input in RS485 mode.

**Y (Pin 6):** Driver Output Y. Inverting RS232 driver Y output in RS232 mode; inverting RS485 driver output in RS485 mode.

**Z (Pin 7):** Driver Output Z. Inverting RS232 driver Z output in RS232 mode; noninverting RS485 driver output in RS485 mode.

## PIN FUNCTIONS

**485/232 (Pin 8):** Interface Mode Select Input. A low logic input enables two RS232 drivers and two RS232 receivers. A high input enables the RS485 driver and the RS485 receiver.

**DXEN (Pin 9):** Driver Enable Input. A high logic input enables the drivers and a low logic input disables the drivers. When disabled, all driver outputs are in high impedance

**GND (Pin 10):** Ground.

**V<sub>EE</sub> (Pin 11):** Charge Pump Negative Supply Output. Requires an external 0.1 $\mu$ F capacitor to ground.

**RXEN (Pin 12):** Receiver Enable Input. A high logic input enables the receivers and a low logic input disables the receivers. When disabled, all receiver outputs are in high impedance.

**ON (Pin 13):** A high logic level at ON input keeps the charge pump active regardless of the state of the DXEN and RXEN inputs. When the charge pump is active, the drivers and receivers can be enabled or disabled without waiting for charge pump stabilization time (typically 100 $\mu$ s with 0.1 $\mu$ F capacitors). A low logic state at the ON, DXEN and RXEN inputs will put the transceiver and charge pump in shutdown mode and reduces I<sub>CC</sub> to 5 $\mu$ A. Whenever the transceiver is activated from shutdown, the charge pump should be allowed to stabilize before data transmission. When DXEN and RXEN are high and ON is low, the charge pump, drivers and receivers are all active and the driver outputs are internally looped back to the inputs of the receiver. The three control inputs ON, DXEN and RXEN can

be configured for one-, two- or three-wire control: one-wire mode – all three inputs connected together; two-wire mode – inputs ON and RXEN connected to one wire, DXEN a separate wire; three-wire mode – separate wires to each input. See the Function Tables.

**D<sub>Z</sub>/SLEW (Pin 14):** Driver Z or Slew Input. In RS232 mode, this pin is the driver Z input. In RS485 mode, this pin controls the slew rate of the RS485 driver. With the SLEW pin high, the RS485 driver runs at maximum (fast) slew rate and can transmit signals up to 5MBd. With the SLEW pin low, the RS485 driver runs with reduced (slow) slew rate to control reflections with improperly terminated cables. In slow mode, the RS485 driver can support data rates up to 150kBd. This SLEW pin has internal 5 $\mu$ A pull-up during RS485 mode.

**D<sub>Y</sub> (Pin 15):** Driver Y Input. Input Y in RS232 mode; the differential driver input in RS485 mode.

**R<sub>B</sub> (Pin 16):** Receiver B Output. Output B in RS232 mode; output is high impedance in RS485 mode.

**R<sub>A</sub> (Pin 17):** Receiver A Output. Output A in RS232 mode; the differential receiver output in RS485 mode.

**V<sub>CC</sub> (Pin 18):** Positive Supply.  $4.75V \leq V_{CC} \leq 5.25V$ . Requires an external 0.1 $\mu$ F bypass capacitor to ground.

**C2<sup>-</sup> (Pin 19):** Commutating Capacitor C2 Negative Terminal. Requires an external 0.1 $\mu$ F capacitor between Pins 19 and 20.

**C2<sup>+</sup> (Pin 20):** Commutating Capacitor C2 Positive Terminal.

# FUNCTION TABLES

## Select Modes

SELECT INPUTS				RECEIVER		DRIVER		CHARGE PUMP	LOOPBACK	COMMENTS
ON	RXEN	DXEN	485/232	RXA	RXB	DXY	DXZ			
1	0	0	0	Z	Z	Z	Z	ON	OFF	RS232 Mode, DX and RX Off
1	0	1	0	Z	Z	ON	ON	ON	OFF	RS232 Mode, DXY and DXZ On, RX Off
1	1	0	0	ON	ON	Z	Z	ON	OFF	RS232 Mode, DX Off, RXA and RXB On
1	1	1	0	ON	ON	ON	ON	ON	OFF	RS232 Mode, DXY and DXZ On, RXA and RXB On
0	0	1	0	Z	Z	ON	Z	ON	OFF	RS232 Mode, DXY On, DXZ Off, RX Off
0	1	0	0	Z	ON	ON	Z	ON	OFF	RS232 Mode, DXY On, DXZ Off, RXA Off, RXB On
0	1	1	0	ON	ON	ON	ON	ON	ON	RS232 Loopback Mode, DXY and DXZ On, RXA and RXB On
0	0	0	X	Z	Z	Z	Z	OFF	OFF	Shutdown, RS485 R <sub>IN</sub>
1	0	0	1	Z	Z	Z	Z	ON	OFF	RS485 Mode, DX and RX Off
X	0	1	1	Z	Z	ON	ON	ON	OFF	RS485 Mode, DX On, RX Off
X	1	0	1	ON	Z	Z	Z	ON	OFF	RS485 Mode, DX Off, RX On
1	1	1	1	ON	Z	ON	ON	ON	OFF	RS485 Mode, DX On, RX On
0	1	1	1	ON	Z	ON	ON	ON	ON	RS485 Loopback Mode, DX On, RX On

### RS232 Driver Mode

SELECTED	INPUTS		CONDITIONS	OUTPUTS Y, Z
	485/232	D		
YES	0	0	No Fault	1
YES	0	1	No Fault	0
YES	0	X	Thermal Fault	Z
NO	0	X	X	Z

### RS232 Receiver Mode

SELECTED	INPUTS		OUTPUTS R <sub>A</sub> , R <sub>B</sub>
	485/232	A, B	
YES	0	0	1
YES	0	1	0
YES	0	Inputs Open	1
NO	0	X	Z

### RS485 Driver Slew Rate

DXEN	INPUTS		OUTPUTS SLEW RATE
	485/232	SLEW	
1	1	0	Slow
1	1	1	Fast
0	1	X	Z

### RS485 Driver Mode

DXEN	INPUTS		CONDITIONS	OUTPUTS	
	485/232	D		Z	Y
1	1	0	No Fault	0	1
1	1	1	No Fault	1	0
1	1	X	Thermal Fault	Z	Z
0	1	X	X	Z	Z

### RS485 Receiver Mode

RXEN	INPUTS		OUTPUTS	
	485/232	B - A	R <sub>A</sub>	R <sub>B</sub>
1	1	< -0.2V	0	Z
1	1	> 0.2V	1	Z
1	1	Inputs Open or Shorted to Ground	1	Z
0	1	X	Z	Z

# BLOCK DIAGRAM

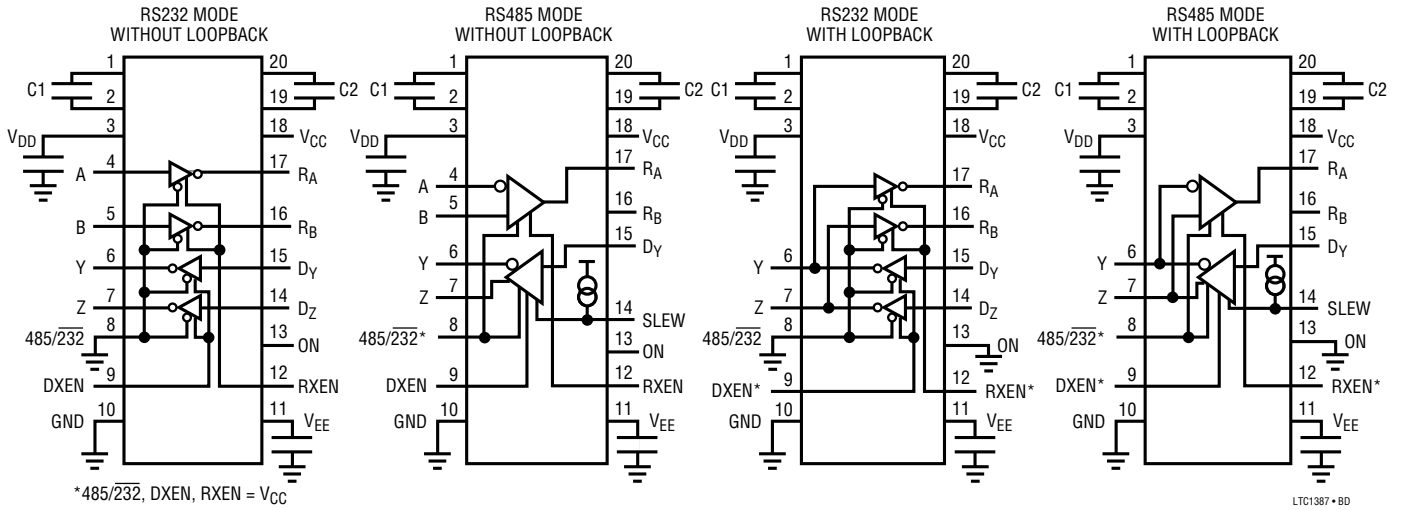

# TEST CIRCUITS

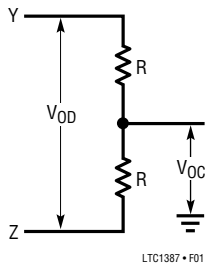

Figure 1. RS485 Driver Test Load

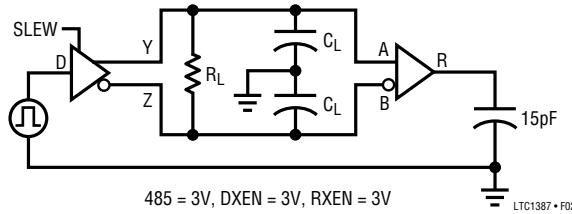

Figure 2. RS485 Driver/Receiver Timing Test Circuit

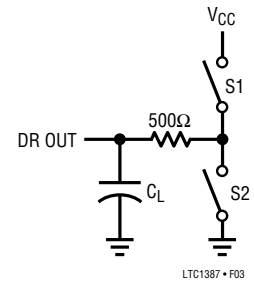

Figure 3. RS485 Driver Output Enable/Disable Timing Test Load

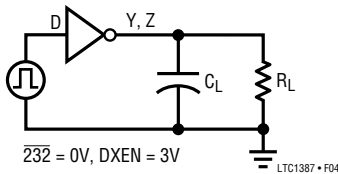

Figure 4. RS232 Driver Timing Test Circuit

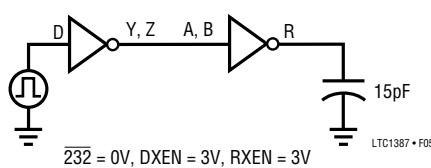

Figure 5. RS232 Receiver Timing Test Circuit

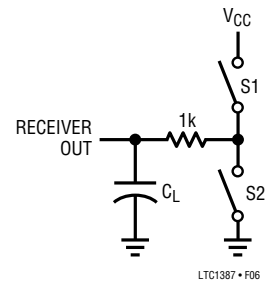

Figure 6. Receiver Output Enable/Disable Timing Test Load

# SWITCHING WAVEFORMS

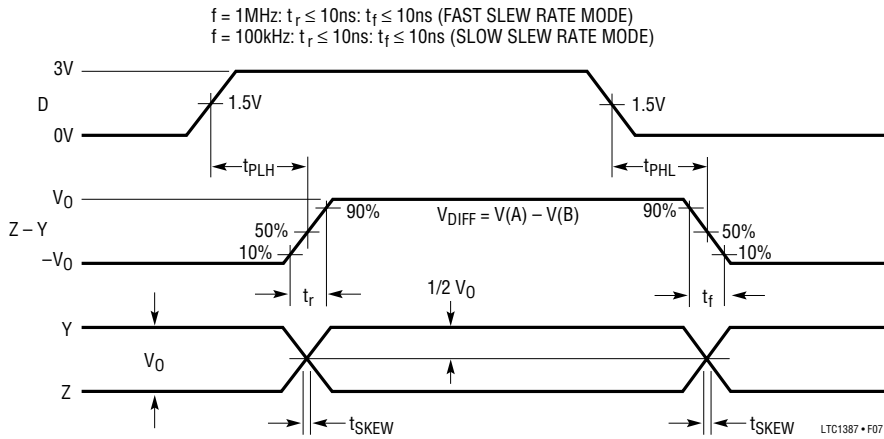

Figure 7. RS485 Driver Propagation Delays

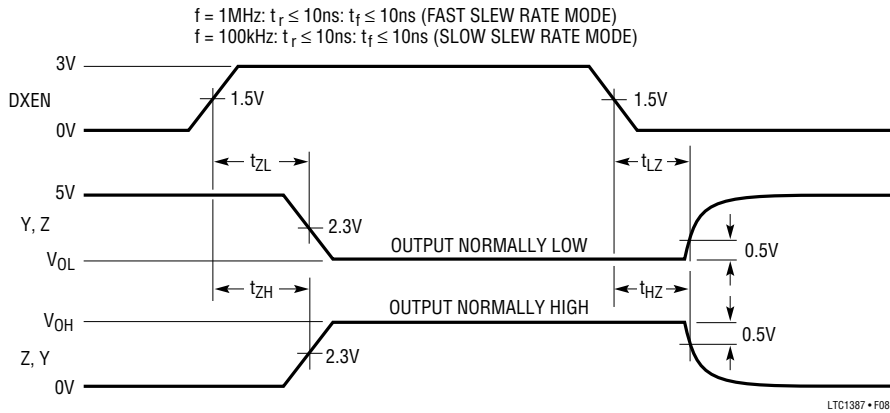

Figure 8. RS485 Driver Enable and Disable Times

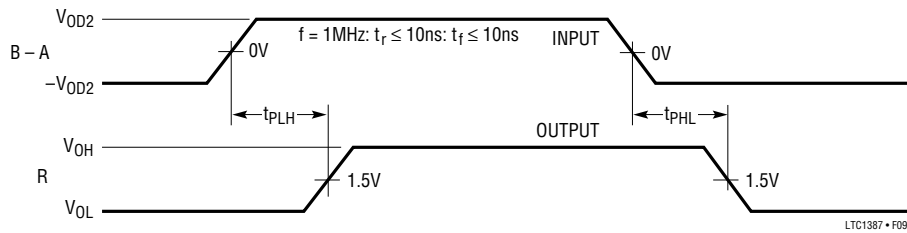

Figure 9. RS485 Receiver Propagation Delays

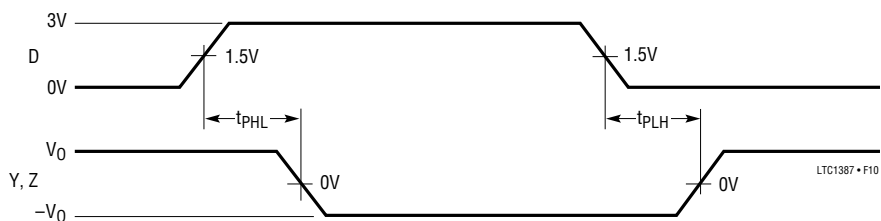

Figure 10. RS232 Driver Propagation Delays



## SWITCHING WAVEFORMS

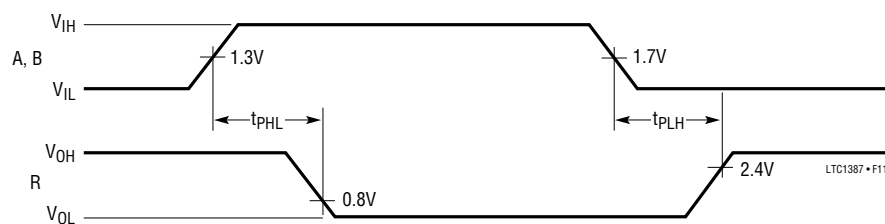

Figure 11. RS232 Receiver Propagation Delays

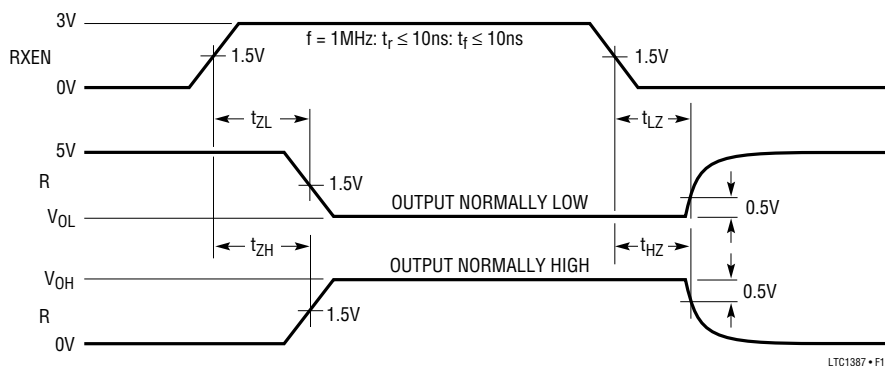

Figure 12. Receiver Enable and Disable Times

## APPLICATIONS INFORMATION

### Basic Theory of Operating

The LTC1387 is a single 5V supply, single-port logic reconfigurable RS485/RS232 transceiver with an onboard charge pump. The interface port offers a flexible combination of an RS485 driver and an RS485 receiver or two RS232 drivers and two RS232 receivers. The RS485 transceiver and the RS232 transceivers are designed to share the same I/O pins. A logic input 485/232 controls the selection between RS485 and RS232 transceiver modes. The RS485 transceiver supports both RS485 and RS422 standards, whereas the RS232 transceivers support both RS232 and EIA562 standards. With four additional control inputs: ON, DXEN, RXEN and SLEW, the LTC1387 can easily be reconfigured via software to adapt to various communication needs including a one-signal-line RS232 I/O mode. Four examples of interface port connections are shown in Figures 13 through 16.

Both the interface drivers and the receivers feature three-state outputs. Driver outputs are forced into high impedance when the driver is disabled, in the shutdown mode or with the power off. The driver outputs can be forced beyond power supply levels without damage up to  $\pm 18V$ . The receiver inputs can withstand  $\pm 25V$  without damage. The receiver input resistance is typically 24k in RS485 mode, shutdown mode or power off but drops to 5k in RS232 mode.

In RS485 mode, the DXEN and RXEN control the three-state outputs of the driver and receiver respectively. The SLEW input is active during RS485 mode and the logic level controls the differential driver slew rate. This pin has an internal 5 $\mu A$  pull-up current source during the RS485 mode. A high logic selects fast differential driver slew rate and a low logic selects slow slew rate. In slow slew mode, the maximum signal bandwidth is reduced, minimizing

## APPLICATIONS INFORMATION

EMI and signal reflection problems. Slow slew rate systems can often use improperly terminated or even unterminated cables with acceptable results. The RS485 differential input receiver features an offset input threshold of  $-80\text{mV}$  at  $0\text{V}$  common mode voltage. This allows the receiver output to have a known High output state when the inputs are open or shorted. The receiver also features an input hysteresis of  $40\text{mV}$ . The charge pump can be kept active regardless of the state of  $\text{DXEN}$  and  $\text{RXEN}$  pins by keeping the  $\text{ON}$  pin High. This improves the receiver response time by removing the  $100\mu\text{s}$  charge pump start-up time.

In RS232 mode, the drivers and receivers can be selected from the Function Tables with control inputs  $\text{ON}$ ,  $\text{RXEN}$  and  $\text{DXEN}$ . The receivers feature a typical  $0.6\text{V}$  input hysteresis.

All the interface driver outputs are fault protected by a current limiting and thermal shutdown circuit. The thermal shutdown circuit disables both the RS232 and RS485 driver outputs when the die temperature reaches  $150^\circ\text{C}$ . The thermal shutdown circuit reenables the drivers when the die temperature cools to  $135^\circ\text{C}$ .

A loopback mode enables internal connections from driver outputs to receiver inputs for self-test. The driver outputs are not isolated from the external loads during loopback.

The charge pump generates boosted positive voltage  $V_{\text{DD}}$  and negative voltage  $V_{\text{EE}}$  for true RS232 levels from a single  $5\text{V}$   $V_{\text{CC}}$  supply. The charge pump requires four  $0.1\mu\text{F}$  capacitors.

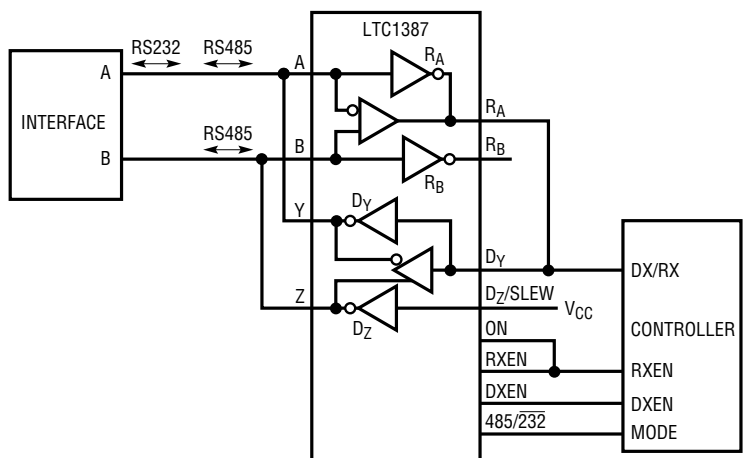

RS232 TRANSMIT MODE	RS232 RECEIVE MODE	RS485 TRANSMIT MODE	RS485 RECEIVE MODE	SHUTDOWN MODE
$\text{RXEN} = 0$	$\text{RXEN} = 1$	$\text{RXEN} = 0$	$\text{RXEN} = 1$	$\text{RXEN} = 0$
$\text{DXEN} = 1$	$\text{DXEN} = 0$	$\text{DXEN} = 1$	$\text{DXEN} = 0$	$\text{DXEN} = 0$
$\text{MODE} = 0$	$\text{MODE} = 0$	$\text{MODE} = 1$	$\text{MODE} = 1$	$\text{MODE} = X$

1387 • F13

Figure 13. Half-Duplex RS232 (1-Channel), Half-Duplex RS485

# APPLICATIONS INFORMATION

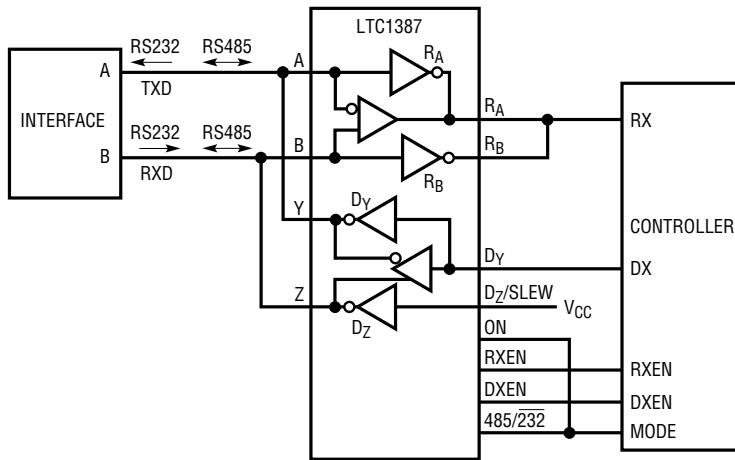

RS232 MODE	RS485 TRANSMIT MODE	RS485 RECEIVE MODE	SHUTDOWN MODE
RXEN = 1	RXEN = 0	RXEN = 1	RXEN = 0
DXEN = 0	DXEN = 1	DXEN = 0	DXEN = 0
MODE = 0	MODE = 1	MODE = 1	MODE = 0

1387 • F14

Figure 14. Full-Duplex RS232 (1-Channel), Half-Duplex RS485

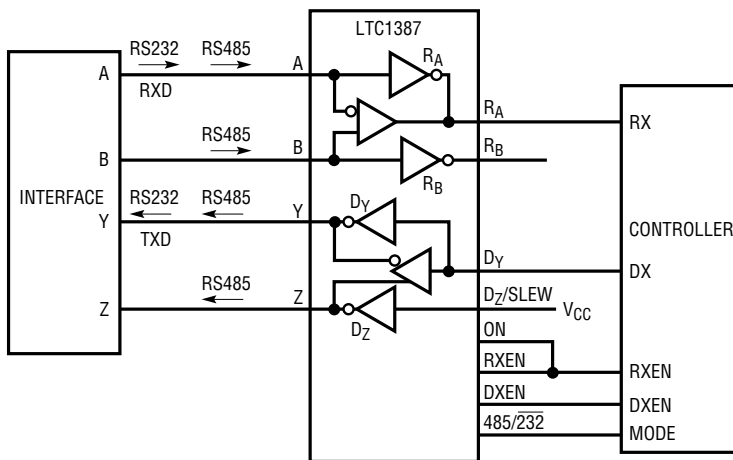

RS232 MODE	RS485 MODE	SHUTDOWN MODE
RXEN = 1	RXEN = 1	RXEN = 0
DXEN = 1	DXEN = 1	DXEN = 0
MODE = 0	MODE = 1	MODE = X

1387 • F15

Figure 15. Full-Duplex RS232 (1-Channel), Full-Duplex RS485/RS422

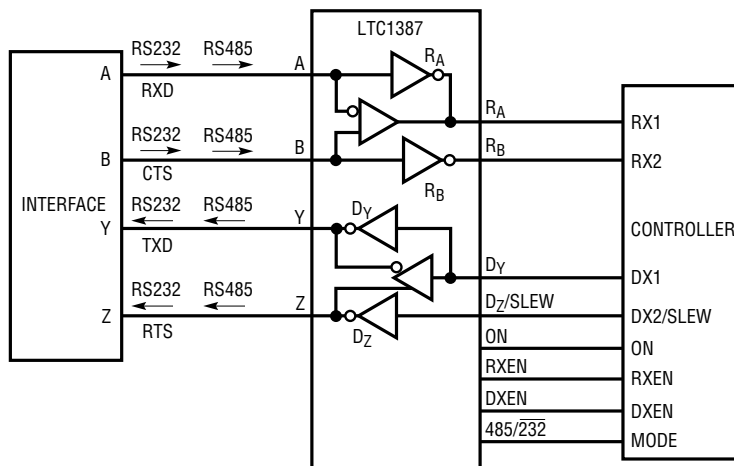

RS232 MODE	RS485 MODE	SHUTDOWN MODE
ON = 1	ON = 1	ON = 0
RXEN = 1	RXEN = 1	RXEN = 0
DXEN = 1	DXEN = 1	DXEN = 0
MODE = 0	MODE = 1	MODE = X

1387 • F16

Figure 16. Full-Duplex RS232 (2-Channel), Full-Duplex RS485/RS422 with SLEW Control