

NOT RECOMMENDED FOR NEW DESIGNS

Contact Linear Technology for Potential Replacement

FEATURES

- Complete Battery Backup System in an SO-8, 16-Pin GN or SO Package
- Generates Fixed Backup Voltage (3.07V/4.63V) from a Single 1.2V NiCd Button Cell
- Automatic Main Supply to Backup Switching
- Minimum 100mW Output Power
- Automatic Fast Recharge of NiCd Battery
- Programmable NiCd Trickle Charge Current
- Smart NiCd Charger Minimizes Recharge Time and Maximizes System Efficiency After Backup
- Onboard Power-Up and Push-Button Reset Generator
- Performs V_{CC} Supervisory Functions
- Reset Assertion Guaranteed at $V_{CC} = 1V$
- Short-Circuit Protection
- Thermal Limiting

APPLICATIONS

- Notebook Computers
- Palmtop Computers/PDAs
- Portable Instruments
- Battery-Powered Systems

DESCRIPTION

The LTC[®]1559 is a backup battery controller that provides all the functions necessary to implement a backup 3.3V or 5V power supply using a single NiCd cell. It includes a 1.2V to 3.07V/4.63V boost converter, an intelligent 2-stage battery charger, automatic backup switching and a micro-processor reset generator. The boost converter uses a synchronous switching architecture to achieve a typical efficiency of 70%, ensuring maximum backup lifetime from a small NiCd cell.

The on-chip NiCd charger uses an internal gas gauge to minimize fast recharge time and prevent overcharging of the backup cell, thereby improving system efficiency and extending the life of the backup cell. The LTC1559 also provides a user programmable trickle charge current to compensate for self-discharge losses in the backup cell.

The LTC1559's automatic backup switching scheme requires minimum intervention from the host system and provides feedback to the host to minimize system loading in the backup state. Its internal V_{CC} fault detector and reset generator eliminate the need for a separate microprocessor supervisory chip in most applications.

The LTC1559 is available in an SO-8, 16-pin GN or SO package.

LT, LTC and LT are registered trademarks of Linear Technology Corporation.

TYPICAL APPLICATION

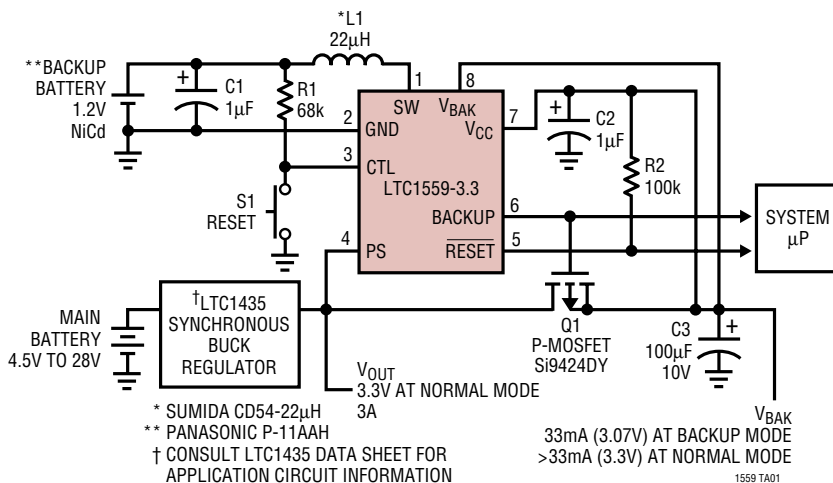

Backup Time vs
 V_{BAK} Output Load Current

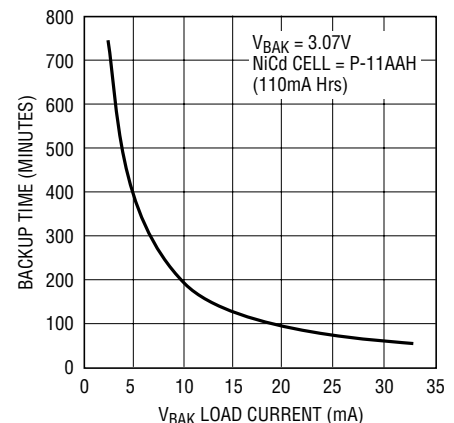

LTC1559-3.3/LTC1559-5

ABSOLUTE MAXIMUM RATINGS

(Note 1)

Terminal Voltages

V_{CC}	6V
V_{BAK}	12V
SW	14V
All Other Pins	-0.3V to $V_{CC} + 0.3V$
SW Input Currents	500mA

V_{BAK} Output Current	Short-Circuit Protected
Operating Ambient Temperature Range	0°C to 70°C
Junction Temperature	125°C
Storage Temperature Range	-65°C to 150°C
Lead Temperature (Soldering, 10 sec)	300°C

PACKAGE/ORDER INFORMATION

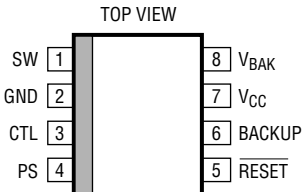
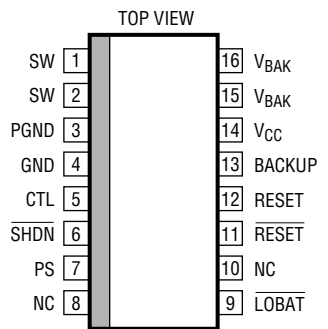
 <p>TOP VIEW</p> <p>SW [1] 8] V_{BAK}</p> <p>GND [2] 7] V_{CC}</p> <p>CTL [3] 6] BACKUP</p> <p>PS [4] 5] RESET</p> <p>S8 PACKAGE 8-LEAD PLASTIC SO</p> <p>$T_{JMAX} = 125^{\circ}C, \theta_{JA} = 130^{\circ}C/W$</p>	ORDER PART NUMBER	 <p>TOP VIEW</p> <p>SW [1] 16] V_{BAK}</p> <p>SW [2] 15] V_{BAK}</p> <p>PGND [3] 14] V_{CC}</p> <p>GND [4] 13] BACKUP</p> <p>CTL [5] 12] RESET</p> <p>SHDN [6] 11] RESET</p> <p>PS [7] 10] NC</p> <p>NC [8] 9] LOBAT</p> <p>GN PACKAGE S PACKAGE 16-LEAD PLASTIC SSOP 16-LEAD PLASTIC SO</p> <p>$T_{JMAX} = 125^{\circ}C, \theta_{JA} = 110^{\circ}C/W$ (GN) $T_{JMAX} = 125^{\circ}C, \theta_{JA} = 110^{\circ}C/W$ (S)</p>	ORDER PART NUMBER
	LTC1559CS8-3.3 LTC1559CS8-5		LTC1559CGN-3.3 LTC1559CGN-5 LTC1559CS-3.3 LTC1559CS-5
	S8 PART MARKING		
	155933 15595		

Consult factory for Industrial and Military grade parts.

ELECTRICAL CHARACTERISTICS

$V_{BAT} = 1.2V, T_A = 0^{\circ}C$ to $70^{\circ}C$ unless otherwise noted.

SYMBOL	PARAMETER	CONDITIONS	MIN	TYP	MAX	UNITS
Battery Backup Switching						
V_{CC}	Operating Voltage Range	LTC1559-3.3 LTC1559-5	● ●	2.900 4.400	3.5 5.5	V V
V_{BAT}	Backup Battery Cell Voltage		●	1.0	1.2 1.5	V
I_{VCC}	Quiescent Supply Current (Note 2)		●	155	250	μA
I_{BAT}	Peak Inductor Current (Backup)	Boost Converter in Low Current Mode (Note 7) Boost Converter in High Current Mode (Note 7)	● ●	80 225	165 330 225 445	mA mA
$I_{BAT(SHDN)}$	Battery Standby Current	$V_{CC} = 0V$	●	0.1	15	μA
$I_{VCC(SHDN)}$	Supply Current During Shutdown (Note 3)		●		50	μA
$V_{BAK(ON)}$	V_{CC} Backup Request/Booster Assertion Trip Point (Note 4)	LTC1559-3.3 LTC1559-5	● ●	3.011 4.475	3.070 4.625 3.127 4.775	V V
$V_{BAK(OFF)}$	V_{CC} Backup Deassertion Trip Point (Note 4)	LTC1559-3.3 LTC1559-5	● ●	3.061 4.550	3.119 4.700 3.176 4.850	V V
V_{LOBAT1}	Low V_{BAT} Detect (Note 3)		●	0.95	1.00 1.05	V
$V_{UVLO(ON)}$	V_{CC} UVLO Trip Voltage (Note 4)	LTC1559-3.3 LTC1559-5	● ●	2.904 4.400	3.003 4.550 3.102 4.700	V V
$V_{UVLO(OFF)}$	V_{CC} UVLO Trip Voltage (Note 4)	LTC1559-3.3 LTC1559-5	● ●	3.061 4.550	3.119 4.700 3.176 4.850	V V

ELECTRICAL CHARACTERISTICS $V_{BAT} = 1.2V$, $T_A = 0^{\circ}C$ to $70^{\circ}C$ unless otherwise noted.

SYMBOL	PARAMETER	CONDITIONS	MIN	TYP	MAX	UNITS	
UVLO Reset Monitor							
V_{LOBAT2}	V_{BAT} UVLO Trip Voltage (Note 5)		●	0.85	0.9	0.95	V
Backup Battery Charger							
I_{CHGF}	Battery Charge Current During Fast Recharge		●	11	16	21	mA
I_{CHGT}	User-Programmable Trickle Charge Current Range		●	0.05		2	mA
Q_{RECH}	Fast Recharge Factor (Note 6)			1.35	1.6	1.85	C/C
Q_{TRK}	Nominal Trickle Charge Multiplier Factor	$I_{CHGT} = 1mA$	●	8	10	12	A/A
$V_{CTL(CLAMP)}$	CTL Clamp Voltage in Trickle Mode	$I_{CHGT} = 1mA$	●	0.45	0.5	0.55	V
Push-Button Reset							
V_{CTL}	CTL Input Threshold					250	mV
t_{CTL}	CTL Input Low Time (Debounce Time)			20	26		ms
Reset Timer							
t_{HRESET}	Push-Button Duration for Hard Reset			1.10	1.8	3.4	sec
t_{RST}	RESET Pulse Width	V_{CTL} Low for $<t_{HRESET}$ (Soft Reset)	●	50	80	150	μs
		V_{CTL} Low for $>t_{HRESET}$ (Hard Reset)	●	115	185	345	ms
V_{RST1}	RESET Output Voltage	$V_{CC} = 1V$, $I_{SINK} = 10\mu A$	●		5	200	mV
V_{RST}	RESET Output Voltage	$V_{CC} = 4.25V$, $I_{SINK} = 1.6mA$	●		0.1	0.4	V
I_{SC}	RESET Output Current	Output Source Current $V_{CC} = 3.3V$			10		mA
		Output Source Current $V_{CC} = 5V$			20		mA
	Short-Circuit Current	Output Sink Current $V_{CC} = 3.3V$			20		mA
		Output Sink Current $V_{CC} = 5V$			40		mA
PS Comparator							
V_{HYST}	Comparator Threshold Hysteresis	$T_A = 25^{\circ}C$			90		mV
Internal V_{CC} Monitor Comparator							
t_r	UVLO, Comparator Propagation Delay (Rising)				7.5		μs
Shutdown Pin (Note 3)							
V_{SHDN}	SHDN Input Threshold	Logic Low, V_{IL} Logic High, V_{IH}	● ●			0.8	V V
I_{SHDN}	SHDN Pin Bias Current	$V_{CC} = 5V$, $V_{SHDN} = 0V$	●		8	15	μA

The ● denotes specifications which apply over the full operating temperature range.

Note 1: Absolute Maximum Ratings are those values beyond which the life of a device may be impaired.

Note 2: Quiescent current is measured during push-button reset.

Note 3: Only applies to 16-pin version.

Note 4: Although the $V_{BAK(ON)}$, $V_{BAK(OFF)}$, $V_{UVLO(ON)}$ and $V_{UVLO(OFF)}$ threshold voltages have a specification tolerance, they are guaranteed by design and tested in production never to overlap.

Note 5: Low cell voltage reset is only triggered when $0.25V < V_{CTL} < 0.9V$ for at least $20\mu s$ while in backup mode.

Note 6: Fast recharge factor is defined as the ratio of charge replenished to the NiCd battery during fast recharge to the charge withdrawn from the NiCd battery during backup.

Note 7: The LTC1559 switches automatically between the low and high operating current levels. See Applications Information for more details.

TYPICAL PERFORMANCE CHARACTERISTICS

Output Power vs Battery Voltage

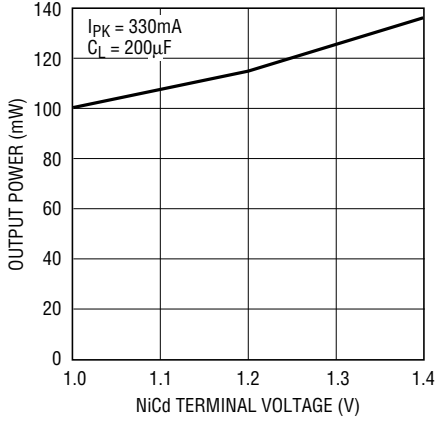

1559 G01

Backup Time vs Battery Capacity

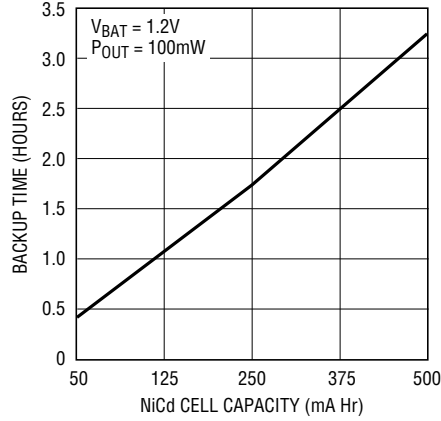

1559 G02

Boost Converter Switching Frequency

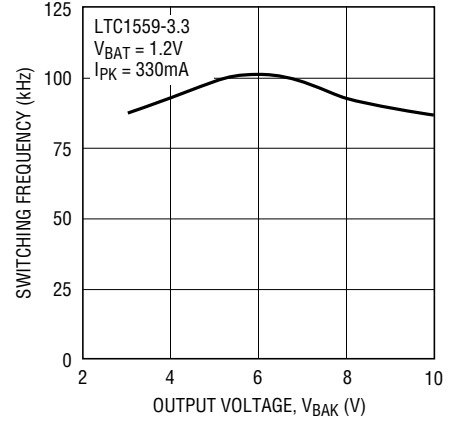

1559 G03

Boost Converter Switching Duty Cycle

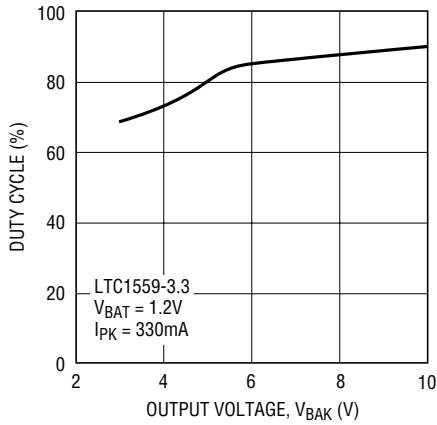

1559 G04

Trickle Charge Multiplier Factor

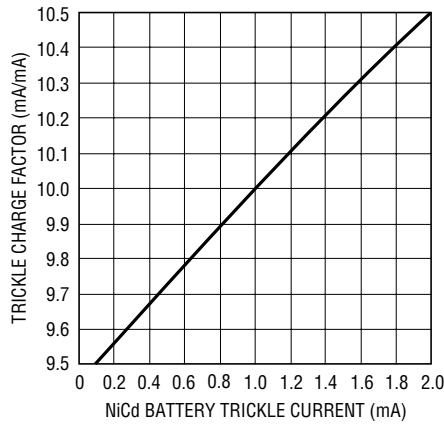

1559 G05

Normalized Fast Recharge Current vs Temperature

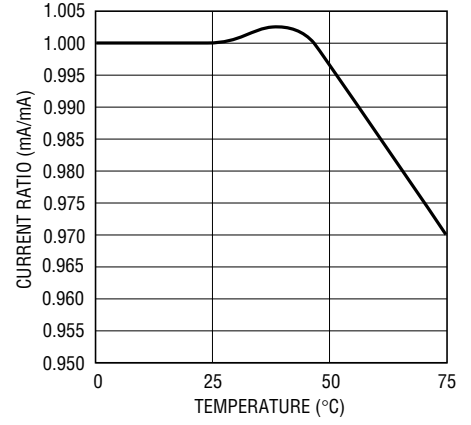

1559 G06

Fast Recharge Time (Assume NiCd Battery Fully Exhausted)

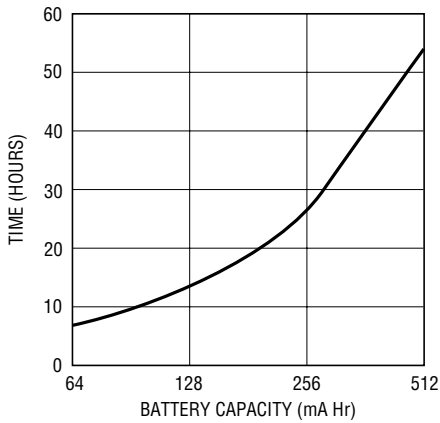

1559 G07

RESET Output Voltage vs Supply Voltage

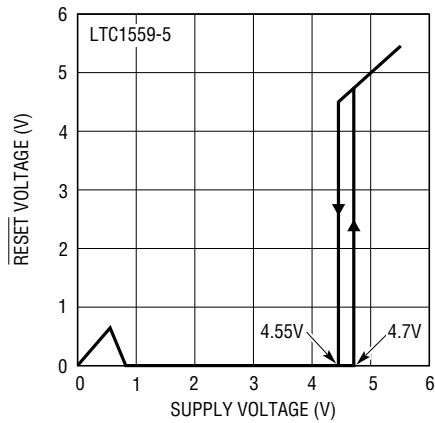

1559 G08

RESET Output Voltage vs Supply Voltage

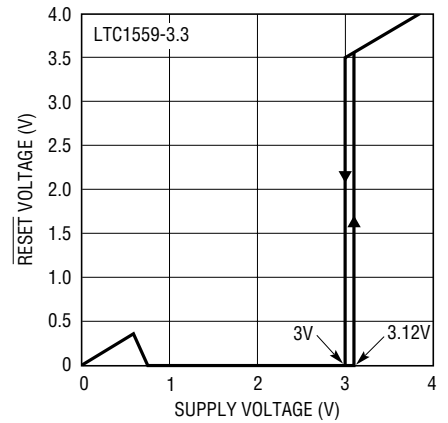

1559 G09

PIN FUNCTIONS

Pin Numbers Are Shown First for the SO-8 Package Then the GN16 and S16 Packages

SW (Pins 1/1, 2): Boost Converter Switching Node. Connect a 22 μ H inductor from SW to the positive terminal of the backup cell. In backup mode, this node is alternately switched between ground and V_{BAK} , generating the backup output voltage. In fast or trickle charge mode, an internal regulator outputs a constant DC current from this pin through the 22 μ H inductor and into the NiCd battery. During power-up or undervoltage lockout (UVLO), the SW pin enters a high impedance state.

GND (Pins 2/4): System Ground. The low power internal circuitry returns to this pin in the 16-pin packages. GND and PGND are bonded together to this pin in the 8-pin package.

CTL (Pins 3/5): Control. This pin provides three functions. In backup mode this pin is a high impedance input and monitors the backup battery cell voltage (V_{BAT}). If V_{BAT} drops below 0.9V, the LTC1559 enters UVLO. During trickle charge mode, an external resistor R_{EXT} sets the trickle charge current. In all modes, pulling the CTL pin below 250mV generates either a “soft” or “hard” reset pulse. See the Applications Information section for more information.

PS (Pins 4/7): Power Supply Sense. This pin senses the presence of the main supply and triggers the LTC1559 to terminate backup mode. During backup, V_{CC} is driven externally by the LTC1559’s boost convert’s output (V_{BAK}). When $\text{PS} > V_{\text{CC}}$ during backup, the LTC1559 pulls down the BACKUP pin, reconnecting the system regulator output to the system V_{CC} . The PS pin is needed in applications that use a P-channel MOSFET (driven by the BACKUP signal) to isolate the system regulator during backup. If not needed, PS can be disabled by tying it to ground.

RESET (Pins 5/11): System Reset, Active Low. This is an open-drain output. This pin provides a low going reset signal to the system processor. A 200ms pulse is generated if the CTL pin is pulled low for more than two seconds (“hard” reset) or if the LTC1559 comes out of UVLO. This “hard reset” stops the internal boost converter if it is running. This pin is held low if the LTC1559 is in UVLO and

is guaranteed to be valid when V_{CC} is greater than or equal to 1V.

$\overline{\text{RESET}}$ also provides a low going 100 μ s signal whenever the CTL pin is pulled low for less than two seconds (“soft” reset). Unlike hard reset, soft reset does not affect the LTC1559’s current operating mode.

BACKUP (Pins 6/13): System Backup Signal. This is a TTL-compatible output driver that pulls low unless the LTC1559 is in backup mode. BACKUP signals the system controller that the system is in backup mode so that it can reduce system loading. BACKUP can also be used to drive the gate of a P-channel MOSFET in series with the main system regulator’s output. See the Applications Information section for more details.

V_{CC} (Pins 7/14): Power Supply Input. All internal circuits except the boost converter are powered from this pin. A 0.1 μ F bypass capacitor is required from V_{CC} to ground. The UVLO detector inside the LTC1559 monitors V_{CC} . If V_{CC} drops below the rated output voltage by 9%, the LTC1559 enters UVLO mode and RESET is asserted. The LTC1559-3.3 exits UVLO if V_{CC} rises to greater than –5.5% of the rated output voltage. The LTC1559-5 exits UVLO if V_{CC} rises to greater than –6% of the rated output voltage. See the Applications Information section for more details.

V_{BAK} (Pins 8/15,16): Backup Supply Output. The LTC1559’s boost converter provides the regulated output voltage to the system through V_{BAK} during backup mode.

16-Pin GN and SO Packages

PGND (Pin 3): Power Ground. The internal driver circuitry returns to this pin. PGND should be connected to a low impedance ground plane in close proximity to the NiCd battery cell.

SHDN (Pin 6): Chip Shutdown. A TTL-compatible active low voltage at SHDN puts the LTC1559 into low power shutdown mode. In shutdown, all internal circuits power down and are held in a reset state. The SW, CTL and V_{BAK} pins enter into high impedance states. In shutdown mode, supply current drops to below 50 μ A and current drawn from the backup cell drops to below 15 μ A.

PIN FUNCTIONS

LOBAT (Pin 9): Low Backup Battery Detector Output. This is an open-drain output with an internal weak pull-up. It is asserted if the NiCd cell terminal voltage drops below 1.0V. This pin is pulled high if the LTC1559 is in trickle charge mode.

RESET (Pin 12): System Reset, Active High. This is a TTL-compatible output driver. It can connect to systems that require active high logic. The RESET output will go high if RESET is pulled low.

BLOCK DIAGRAM

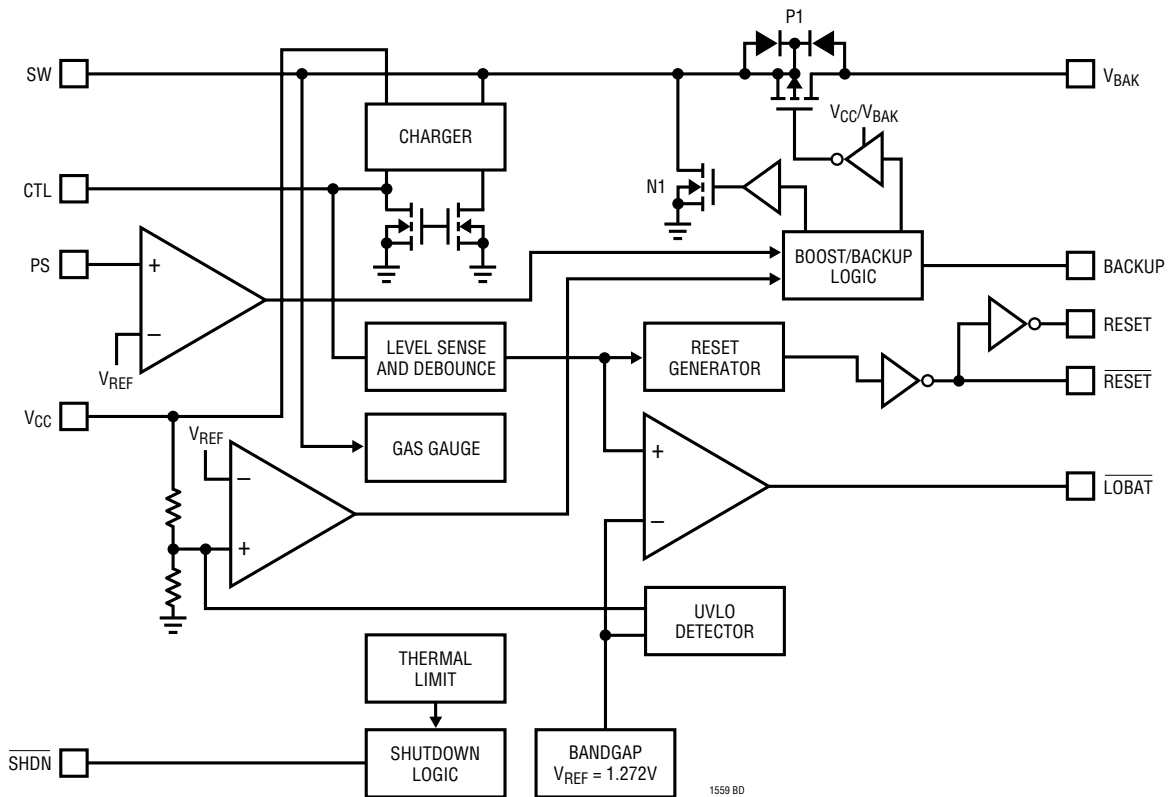

SWITCHING WAVEFORMS

Simplified LTC1559 Connections in a Battery Backup System

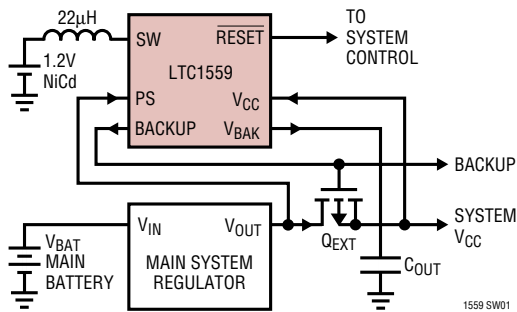

FOR MORE DETAILED CIRCUIT APPLICATION SCHEMATICS, PLEASE REFER TO THE TYPICAL APPLICATIONS SECTION

Cold Power Boot-Up (Main Battery Replaced/Turned On)

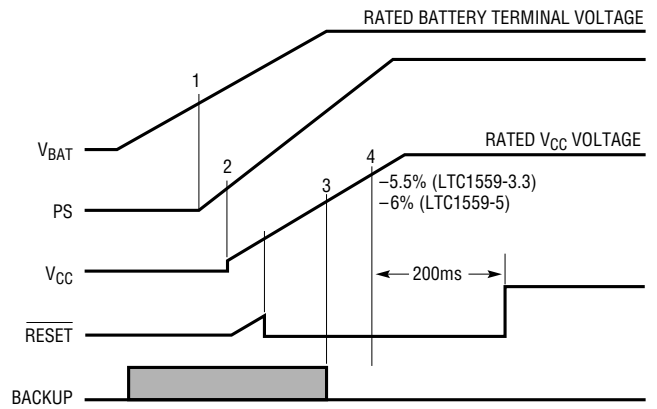

SWITCHING WAVEFORMS

Cold Power Boot-Up Description

1. System regulator starts to ramp up the output (PS) once the V_{BAT} voltage increases beyond the minimum input value.
2. V_{CC} starts to increase once PS is high enough to turn on Q_{EXT} 's body diode. \overline{RESET} is asserted when V_{CC} is less than or equal to 1V.
3. The LTC1559's internal bandgap wakes up. Q_{EXT} turns on and $V_{CC} = PS$. The LTC1559's internal boost converter does not turn on as \overline{RESET} remains asserted.
4. \overline{RESET} is asserted for a further 200ms after V_{CC} reaches -5.5% of its rated V_{CC} value for the LTC1559-3.3 and -6% of its rated V_{CC} value for the LTC1559-5.

Backup Mode (Main Battery Discharged)— LTC1559-3.3

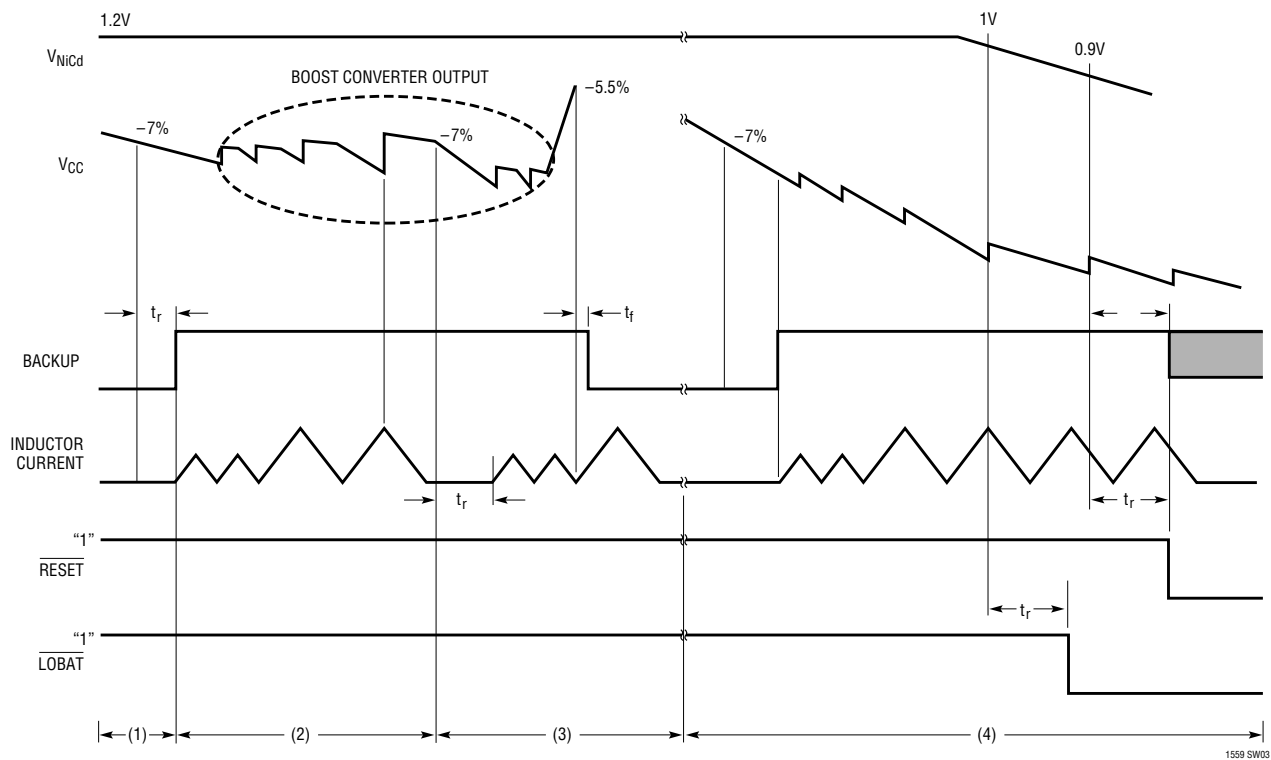

Backup Mode Description

1. Trigger into Backup Mode. Main battery fails and V_{CC} drops 7% below the rated value. The backup pin is asserted after a t_r delay time and the boost converter is turned on.
2. Backup Mode. The LTC1559's boost converter charges and discharges the inductor with 165mA peak current. If V_{CC} doesn't increase above $V_{CC}(\text{rated value}) - 7\%$ (due to a heavy load), the boost converter increases peak charging current to 330mA. If V_{CC} rises above $V_{CC}(\text{rated value}) - 7\%$, the boost converter stops and the backup pin remains asserted.
3. Recovery from Backup Mode. While the boost converter is running, the main battery is restored. This causes the system regulator to increase PS above V_{CC} . When $PS > V_{CC}$ or $V_{CC} > V_{CC}(\text{rated value}) - 5.5\%$, the BACKUP pin deasserts and the boost converter finishes its last cycle.
4. Trigger into UVLO. During backup, the 1.2V NiCd cell is discharged and its terminal voltage falls. The LOBAT pin is asserted to give an early warning if the cell voltage drops below 1V. \overline{RESET} is asserted when the cell voltage drops below 0.9V and the LTC1559 enters UVLO mode.

APPLICATIONS INFORMATION

Overview

The LTC1559 is a versatile backup battery control system designed to provide all the functions necessary to implement a complete, highly integrated backup system within a single chip. It allows the system to maintain its rated supply voltage during backup, offering maximum system design flexibility. The LTC1559 allows the use of a low cost rechargeable NiCd cell for backup, eliminating the need for expensive, replaceable 4.5V lithium backup cells.

The LTC1559 includes an onboard boost converter designed to generate a fixed voltage (3.07V for 3.3V parts and 4.625V for 5V parts) from a single 1.2V NiCd cell. When connected to the system DC/DC converter's output, the LTC1559 enables the system connected to the V_{CC} rail to continue operation when the main power supply fails. A "smart" recharging circuit uses an accumulating gas gauge to measure the charge extracted from the backup battery during a backup cycle. This measured charge is then replaced in a fast recharge cycle, without wasting excess power or overcharging the backup cell. An externally adjustable trickle charge circuit maintains the cell charge after the fast charge cycle has completed, minimizing drain from the main battery during standby.

Included in the LTC1559 is a complete backup circuit that monitors the main system power and automatically switches in the backup circuit as the primary power supply falls away (due to a weak or disconnected main battery). The LTC1559 also performs V_{CC} supervisory functions during normal system operations. An LTC1559-3.3 monitors a 3.3V supply voltage at its V_{CC} pin while an LTC1559-5 monitors a 5V supply at its V_{CC} pin. In both cases, the LTC1559 derives power for the majority of the internal circuitry (except for the boost converter) from its V_{CC} pin. Table 1 shows the signal conditions for the various operating modes of the LTC1559-3.3. Table 2 shows the signal conditions for the various operating modes of the LTC1559-5.

Table 1. LTC1559-3.3 Operating Modes

OPERATING MODES	CONDITIONS
UVLO Reset	$1V < V_{CC} < V_{CC}(\text{rated value}) - 9\%$ or $V_{BAT} < 0.9V$
Push-Button Reset	$V_{CTL} < 250mV$
UVLO Reset Recovery	$V_{CC} > V_{CC}(\text{rated value}) - 5.5\%$
Backup Mode Activation	$V_{CC} < V_{CC}(\text{rated value}) - 7\%$
Backup Mode Exit	$V_{CC} > V_{CC}(\text{rated value}) - 5.5\%$ or $PS > V_{CC}$
Boost Converter Activation	$V_{CC} < V_{CC}(\text{rated value}) - 7\%$
Boost Converter Deactivation	$V_{CC} > V_{CC}(\text{rated value}) - 7\%$

Table 2. LTC1559-5 Operating Modes

OPERATING MODES	CONDITIONS
UVLO Reset	$1V < V_{CC} < V_{CC}(\text{rated value}) - 9\%$ or $V_{BAT} < 0.9V$
Push-Button Reset	$V_{CTL} < 250mV$
UVLO Reset Recovery	$V_{CC} > V_{CC}(\text{rated value}) - 6\%$
Backup Mode Activation	$V_{CC} < V_{CC}(\text{rated value}) - 7.5\%$
Backup Mode Exit	$V_{CC} > V_{CC}(\text{rated value}) - 6\%$ or $PS > V_{CC}$
Boost Converter Activation	$V_{CC} < V_{CC}(\text{rated value}) - 7.5\%$
Boost Converter Deactivation	$V_{CC} > V_{CC}(\text{rated value}) - 7.5\%$

Boost Converter Operation

The LTC1559 uses an onboard boost converter with a fixed peak current architecture that provides a simple and flexible system solution while eliminating the need for conventional frequency compensation. The boost converter's output, set to 93% (LTC1559-3.3) or 92.5% (LTC1559-5) of the rated V_{CC} , supports the system V_{CC} during backup. It supplies a minimum backup power of 100mW. The boost converter operates in a modified pulse-skipping mode; each switch cycle transfers a known amount of charge from the backup cell to the regulated output. This prevents uncontrolled discharge of the backup cell and allows the LTC1559 to accurately measure the charge removed from the backup cell by counting the charge pulses.

The LTC1559 enters backup mode when the main battery voltage drops and causes V_{CC} , the system regulator's output, to fall. As shown in Figure 1, V_{CC} is scaled down by an internal resistor divider and fed to the LTC1559's backup comparators. These compare the scaled voltage

APPLICATIONS INFORMATION

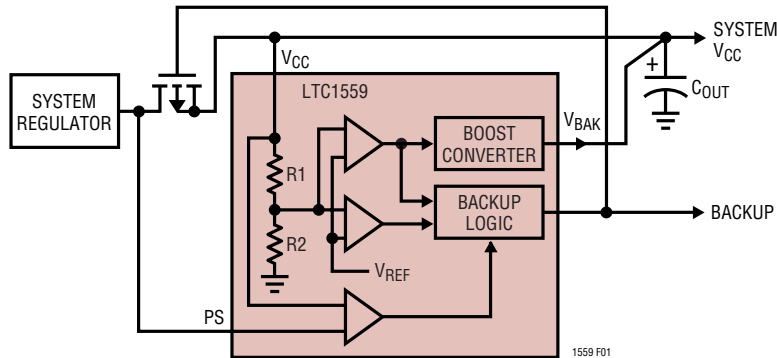

Figure 1. Typical LTC1559 Connection

with an internal trimmed V_{REF} (1.272V), switching the LTC1559 into backup mode if V_{CC} drops 7% (LTC1559-3.3) or 7.5% (LTC1559-5) below its rated value. Upon entering backup mode, the BACKUP pin is asserted and the internal boost converter turns on. The BACKUP signal turns off the external P-channel MOSFET (if used), isolating the system regulator from the LTC1559. The boost converter charges the V_{CC} capacitor, C_{OUT} , of the system regulator until V_{CC} rises above V_{CC} (rated value) – 7% (LTC1559-3.3) or V_{CC} (rated value) – 7.5% (LTC1559-5).

Once V_{CC} rises above V_{CC} (rated value) – 7% (LTC1559-3.3), the boost converter deactivates and the freshly charged V_{CC} capacitor C_{OUT} supplies power to the system. The cycle repeats again when the V_{CC} capacitor's charge is drained away and V_{CC} again drops below V_{CC} (rated value) – 7% (LTC1559-3.3). The BACKUP pin remains asserted until the main battery is restored. This ensures that the LTC1559 does not switch in and out of backup mode unnecessarily.

The LTC1559's boost converter minimizes output ripple under light load conditions by reducing the charge trans-

ferred for the first two consecutive switch cycles. If V_{CC} falls below V_{CC} (rated value) – 7% (LTC1559-3.3), the boost operation starts by connecting the SW pin internally to ground through an internal 0.5Ω N-channel MOSFET (N1 in the Block Diagram). The current through the external 22μH inductor rises linearly through this switch.

When the switch current reaches an internally preset level of 165mA, the boost converter connects the SW pin to the V_{BAK} pin through an internal 2Ω P-channel MOSFET. The inductor current discharges through the P-channel (P1 in the Block Diagram) and charges up the system's V_{CC} capacitor (C_{OUT} of the system regulator, Figure 1). The inductor current falls at a rate proportional to the difference between the backup cell voltage and the output voltage V_{BAK} . When the inductor current reaches zero, indicating all of its energy has been transferred to the output capacitor, the LTC1559 monitors the V_{CC} voltage. If V_{CC} has increased above the V_{CC} (rated value) – 7% (LTC1559-3.3) threshold, the boost converter shuts off both switches and waits for V_{CC} to drop below V_{CC} (rated value) – 7% (LTC1559-3.3) again.

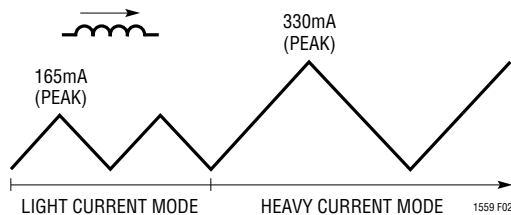
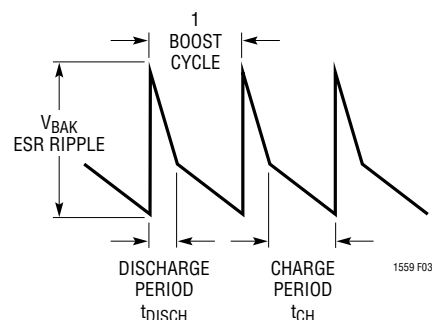

Figure 2. Inductor Current During Switching

Figure 3. V_{BAK} Ripple

APPLICATIONS INFORMATION

If V_{CC} is still less than V_{CC} (rated value) -7% (LTC1559-3.3) after the first boost cycle, the LTC1559 immediately reconnects SW to ground, repeating the boost cycle. If after two consecutive pulses, V_{CC} is still not above the boost threshold V_{CC} (rated value) -7% (LTC1559-3.3), the LTC1559 decides that the load is not so light after all, and doubles the internal inductor charging current limit to 330mA for subsequent cycles. This is high current mode. By doubling the peak inductor current, each boost cycle effectively carries four times more energy compared to low current mode ($E = 1/2 \cdot L I^2$), doubling the available output power. When V_{CC} exceeds the V_{CC} (rated value) -7% (LTC1559-3.3) boost threshold, the LTC1559 stops the boost converter and resets the internal 2-pulse counter. The next time V_{CC} falls below V_{CC} (rated value) -7% (LTC1559-3.3), the boost converter restarts in low current mode for at least two boost cycles. Moderate or changing loads cause the LTC1559 to shift between the two peak inductor current limits, keeping the output in tight regulation. Near its maximum load capability, the LTC1559 will stay in 330mA high current mode and the output voltage V_{BAK} will hover around V_{CC} (rated value) -7% (LTC1559-3.3).

V_{CC} Capacitor ESR

The type of output capacitor and the rated V_{CC} value will affect the LTC1559's output ripple and efficiency. In most applications, the V_{CC} capacitor is primarily determined by the requirements of the main power supply. Such a capacitor will generally meet the requirements of the LTC1559. In unusual circumstances or circuits where the main system V_{CC} capacitor is located some distance away from the LTC1559, a local output capacitor may be necessary.

The ripple on the V_{CC} pin is equal to the capacitor ESR voltage drop due to the boost converter's output current pulses. The ripple frequency and output duty cycle is proportional to the inductor discharge time. Given a fixed inductor value (22 μ H) and a known peak current limit, the booster's discharge time in each boost cycle is proportional to the difference between V_{BAK} (93% of the rated V_{CC} for the LTC1559-3.3 and 92.5% of the rated V_{CC} for the LTC1559-5) and the battery cell voltage, V_{BAT} (1.2V).

Assuming $ESR = 0.2\Omega$, $I_{IND(PEAK)} = 330mA$, $V_{CC} = 5V$,

$$\begin{aligned} V_{RIPPLE(P-P)} &= (I_{IND(PEAK)})(R_{ESR(CAP)}) \\ &= (330mA)(0.2\Omega) \\ &= 66mV \end{aligned}$$

Since V_{CC} must be scaled down internally, the external resistor ratio:

$$\begin{aligned} &= 5V/1.272V \\ &= 3.931 \end{aligned}$$

Therefore the ripple seen by the V_{CC} comparators is:

$$\begin{aligned} &= 66mV/3.931 \\ &= 16.79mV \end{aligned}$$

The discharge time period,

$$\begin{aligned} t_{DISCH} &= (L \cdot I_{IND(PEAK)})/(V_{BAK} - V_{BAT}) \\ &= (22\mu H \cdot 330mA)/(4.625 - 1.2V) \\ &= 2.12\mu s \end{aligned}$$

For $V_{CC} = 3.3V$ and $I_{IND(PEAK)} = 330mA$,

$$\begin{aligned} V_{RIPPLE(P-P)} &= 66mV \\ RB \text{ resistor ratio} &= 3.3/1.272 = 2.594 \\ \text{Ripple voltage} &= 25.4mV \\ t_{DISCH} &= 3.9\mu s \end{aligned}$$

The internal V_{CC} comparators are designed to have a slow response time to filter away this ripple. The V_{CC} (rated value) -5.5% (LTC1559-3.3) and V_{CC} (rated value) -9% comparators have a 6 μ s rising edge delay and 2 μ s falling edge delay. The V_{CC} (rated value) -7% (LTC1559-3.3) comparator has a similar 6 μ s rising time delay but a much longer falling time delay of 20 μ s. This enables the comparator to control the boost converter properly, and avoids turning off the boost converter prematurely due to false triggering by the ESR ripple.

Exit from Backup

When a main battery is inserted into the system, the LTC1559 follows a specific sequence to exit backup mode and return control to the main supply. The sequence depends on the type of main power supply used. In systems where the main supply's output impedance is

APPLICATIONS INFORMATION

high when inactive (typically a boost regulator with an output catch diode), the LTC1559 detects the return of the main supply by watching for V_{CC} to exceed V_{CC} (rated value) – 5.5% (LTC1559-3.3). The LTC1559 then shuts down its internal boost converter and begins to recharge the NiCd cell. In such applications, the PS pin is not used and can be tied to ground. No external P-channel MOSFET is required to isolate the main supply from the system V_{CC} during backup.

In systems where the main supply's output impedance is low when inactive (typically buck regulators), the main supply must be disconnected from the system V_{CC} during backup to prevent the inactive supply from loading the LTC1559. This is typically accomplished using an external P-channel MOSFET as shown in Figure 1. When the main supply is restored, the P-channel MOSFET's body diode forward-biases. This allows current to flow into the system V_{CC} , but the forward drop across this diode may prevent V_{CC} from reaching the V_{CC} (rated value) – 5.5% (LTC1559-3.3) threshold that deactivates the LTC1559's backup mode. In such systems, the PS pin should connect directly to the output of the main system supply. When the system regulator's voltage rises about 2.5% above the backup V_{CC} , the PS comparator triggers and causes the LTC1559 to deassert the BACKUP pin signal. This signals the system controller to restore system loading and resume normal operation. At the same time, the external P-MOSFET is driven by the BACKUP signal. The P-channel MOSFET turns on and allows the main regulator to bypass its body diode and drive the system V_{CC} directly.

Since the user can replace the main battery anytime during the LTC1559's backup operation, the BACKUP signal may be deasserted while the boost converter is switching. To prevent the potential problem of residual energy in the inductor, the LTC1559 will only stop the boost converter after it completes the current boost converter cycle.

UVLO Under Excessive Backup Load

Very heavy loads (above the LTC1559's maximum power output) will pull the boost converter's output below the boost threshold. Under these conditions, the LTC1559's boost converter continues to supply 330mA current pulses

to the load while charge on the V_{CC} capacitor drains away. If V_{CC} drops below V_{CC} (rated voltage) – 9% for more than 7.5 μ s, the LTC1559's V_{CC} supervisory circuit activates UVLO mode, shutting off the boost converter and asserting the Reset pins. The 7.5 μ s delay prevents the LTC1559 from being fooled by brief transients or noise spikes on its V_{CC} pin. Upon receipt of the reset signal, the host system should shut down in an orderly manner. The LTC1559's V_{CC} supervisory circuit will remain alive until V_{CC} is less than 1V to ensure a valid RESET pin signal.

Backup Cell Voltage Monitoring

As the boost converter removes charge from the backup NiCd cell, the cell's terminal voltage falls. Permanent damage to the NiCd cell can occur if it is discharged to below 0.9V. To prevent this, the LTC1559 monitors the cell's terminal voltage through the CTL pin during backup. If the CTL pin drops below 0.9V for more than 20 μ s, the UVLO circuit shuts down the boost converter and asserts the RESET and $\overline{\text{RESET}}$ pins. Since the CTL pin can also be connected to an external push-button reset, the LTC1559 includes internal logic to ensure that the low cell voltage reset is triggered only if the CTL pin is between 0.9V and 0.25V. This will prevent a push-button reset (which pulls CTL below 250mV) from being mistaken as a low cell voltage condition. Unusual situations where the NiCd cell voltage drops drastically below 0.25V will also trigger UVLO, since the LTC1559 will treat this as a "hard" reset after two seconds.

An optional $\overline{\text{LOBAT}}$ output, available in the 16-pin GN or SO package, can be used to signal the system if the cell voltage falls below 1V, giving an early warning that the backup cell is heavily discharged. The $\overline{\text{LOBAT}}$ pin is disabled if the LTC1559 is in trickle charge mode, because the CTL pin is regulated to 0.5V by the LTC1559.

Fault Protection and Thermal Limit

The LTC1559's boost converter incorporates two internal timers that turn off the switch transistors if the inductor charge or discharge time gets abnormally long.

The inductor charge time may get abnormally long if the NiCd cell voltage drops below 0.25V without triggering the 0.25V < V_{BAT} < 0.9V low cell voltage comparator. In this

APPLICATIONS INFORMATION

case, the NiCd cell is assumed to be damaged and the LTC1559's priority is shutting down the system gracefully. In this case, the timer will shut off the N-channel switch transistor after a maximum charging time (14 μ s). The boost converter continues switching but delivers reduced output power, causing V_{CC} to drop. The LTC1559 enters UVLO if V_{CC} drops below $V_{CC}(\text{rated value}) - 9\%$ or if the LTC1559 detects that CTL is lower than 0.25V for two seconds, in which case "hard" reset occurs.

The discharge time can also get abnormally long if a serious overload condition occurs during switching. The timer shuts off the P-channel pass transistor after 10 μ s, protecting the boost converter. The LTC1559 enters UVLO as V_{CC} drops below $V_{CC}(\text{rated value}) - 9\%$.

In addition, the LTC1559 has safe area operation protection with an internal thermal shutdown circuit. If the device is overloaded for a long period of time, the thermal shutdown circuit forces the LTC1559 into UVLO. The threshold temperature for thermal shutdown is typically 155°C.

The LTC1559's boost converter is designed so that no current drains from the battery to the load during output short circuit or $V_{CC} = 0V$ conditions. This assures that the system can be powered down for a long period of time. This eliminates the risk of finding a nonfunctioning backup system upon power-up.

Backup Cell Fast Recharge

The LTC1559 includes an onboard gas gauge circuit, consisting of a 23-bit divider and a 9-bit up/down counter. The gas gauge logic assumes that the boost converter uses a 22 μ H inductor, allowing it to accurately measure battery charge by counting pulses. The gas gauge counts up from zero as charge is removed from the backup cell in backup mode. It takes 8.4 million 165mA boost pulses (low current mode) to increment the up/down counter by one count. In high current mode, the 330mA pulses skip the first two bits of the divider because each 330mA pulse carries four times as much energy as a 165mA pulse. At maximum load and $V_{CC} = 4.625V$ (LTC1559-5), the gas gauge counter will increment by one count every 7.5 μ s while the boost converter is running. Full count is reached

after approximately 2.2 hours, equivalent to about 512mAh of charge.

Upon entering recharge mode (after the main battery is restored) the LTC1559 connects a 16mA fast recharge current source from V_{CC} to the SW pin. At the same time, an internal free running oscillator counts down the gas gauge counter at a rate designed to typically replace 160% of the charge previously removed from the backup cell. When the gas gauge counter reaches zero, the LTC1559 reduces the charging current at the SW pin to the user-programmed trickle charge current level.

Under some circumstances, the LTC1559 can exit backup mode with invalid gas gauge contents. This occurs under three possible conditions:

1. The backup cell was completely exhausted during a backup cycle and the LTC1559 entered UVLO.
2. The backup cell was replaced while the main supply was disabled.
3. A backup cycle was terminated prematurely by a "hard" reset or an output overload.

In these cases, the LTC1559 assumes that the backup cell is exhausted and presets the gas gauge counter to a default capacity of 128mAh. It then initiates a recharge cycle.

Setting the gas gauge to this default value results in a fast recharge cycle long enough to replenish 1.6 times 128mAh into the backup cell (13.9 hours). If the backup cell is actually exhausted, it will be fully recharged. If the battery is partially or fully charged, or is significantly smaller than 128mAh capacity, the extra charging time is wasted. However, the LTC1559's 16mA fast charge current is not high enough to damage the cell. Once the full-count recharge has been completed, the backup cell is assumed to be fully charged and subsequent backup/recharge cycles resume normally.

Although the LTC1559 will not fully recharge backup cells larger than 128mAh capacity upon power-up, it can still be used with such cells. Such a cell will be fully replenished by the subsequent trickle charge cycle. Under most conditions, even a partially charged large cell will still be capable of supporting several hours of backup. For

APPLICATIONS INFORMATION

example, a small 60mAhr SAFT cell can back up the system for 20 minutes at an output power of 100mW. Note that at $V_{CC} = 3.07V$ (LTC1559-3.3), the boost converter efficiency improves and allows more backup time from the same cell compared to $V_{CC} = 4.625V$ (LTC1559-5).

Once it reaches full recharge, a cell bigger than 512mAhr will overrun the gas gauge counter before it runs out of charge during an extended backup cycle. The LTC1559 gas gauge counter will not roll over if this occurs; it will stay at full count until the backup cycle ends and then partially recharge the cell with a full count cycle as above.

Very short backup cycles (<32s) may not extract enough charge from the backup cell to increment the gas gauge counter at all. To ensure that the backup cell is not slowly “nibbled” away, the gas gauge counter is always incremented by 1mAhr each time the controller exits backup. This ensures that the backup cell is replenished with at least a 1mAhr charge every time the LTC1559 enters backup mode.

Battery Backup Cell Trickle Charge

When the gas gauge counter reaches zero, the LTC1559 terminates fast recharge and reduces the recharge current to the user-programmed trickle current level. The LTC1559 provides a trickle current that the user can program from 50 μ A to 2mA. The trickle current is set by an external resistor from the positive terminal of the backup cell to the

CTL pin. In trickle charge mode, CTL is regulated to 0.5V, resulting in a CTL pin current of $(V_{BAT} - 0.5)/R_{EXT}$. This current is internally multiplied to feed back ten times the R_{EXT} current into the backup battery. Since the LTC1559 trickle charges only after the completion of the fast recharge cycle, the backup cell voltage should be very close to 1.2V. This simplifies the calculation of the R_{EXT} resistor value. For example, a 47k resistor from V_{BAT} to CTL sets the trickle charge current to 150 μ A.

Undervoltage Lockout

The LTC1559 includes an undervoltage lockout (UVLO) circuit that shuts the system down gracefully if the backup cell is exhausted or overloaded. As described in the previous section, the LTC1559 terminates backup operation and remains off until the main power supply returns. It then runs a fast recharge cycle to recharge the backup cell. An onboard low-battery comparator in the 16-pin GN or SO package provides an early warning signal if the backup cell drops below 1V.

The UVLO circuit trips if the LTC1559's V_{CC} supervisory circuit detects that V_{CC} drops below -9% of the rated V_{CC} voltage due to overload or output short-circuit conditions. Once the UVLO circuit trips, the LTC1559 asserts the RESET and \overline{RESET} pins until the V_{CC} voltage drops below 1V. It then remains off until V_{CC} rises to within -5.5% of the rated output voltage (LTC1559-3.3). During power-up from UVLO, the LTC1559 asserts the RESET and \overline{RESET} pins until the $V_{CC}(\text{rated value}) - 5.5\%$ (LTC1559-3.3) threshold. Once V_{CC} exceeds $V_{CC}(\text{rated value}) - 5.5\%$ (LTC1559-3.3), the RESET and \overline{RESET} pins remain asserted for another 200ms (“hard” reset) before being released to inform the system to start operating.

Reset Operation

The LTC1559 includes an onboard push-button reset switch controller. If the CTL pin is pulled to ground (<250mV) by a push-button or an open-drain output, the LTC1559 generates a pulse at the RESET and \overline{RESET} pins after the trailing edge of the CTL signal. A short (less than two seconds) low going signal at CTL generates a “soft” reset (100 μ s) pulse at the reset pins. A low CTL signal for more than two seconds generates a “hard” reset pulse at the RESET and \overline{RESET} pins. During “hard” reset, the

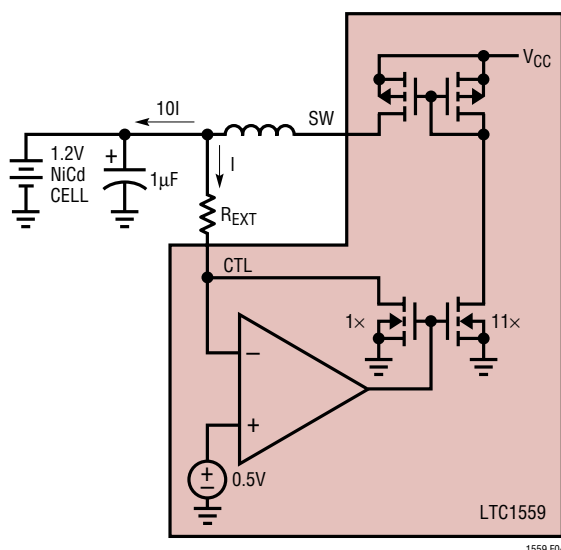

Figure 4. Trickle Current Charger

APPLICATIONS INFORMATION

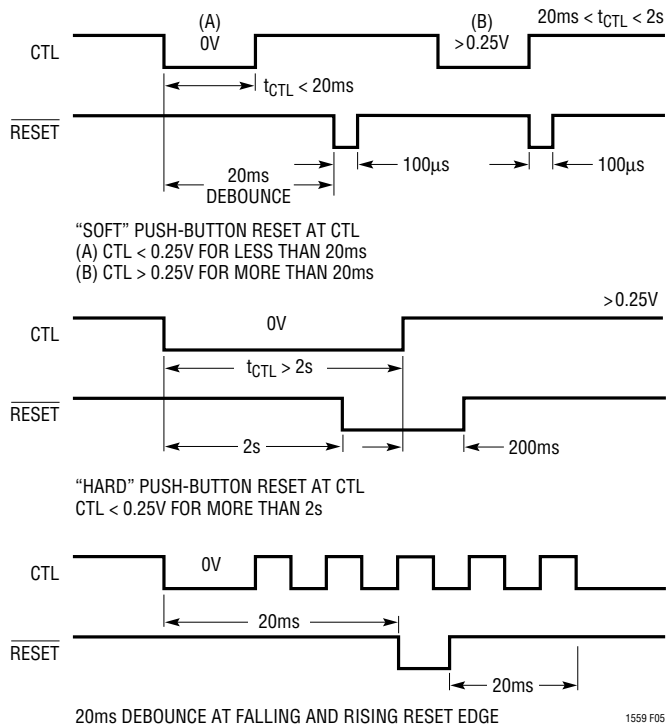

Figure 5. Push-Button Resets

LTC1559 disables the boost converter if it is in backup mode. All signals at the CTL pin are debounced for 20ms to prevent multiple resets, allowing the CTL pin to be connected directly to a push-button to ground.

The $\overline{\text{RESET}}$ pin is an open-drain output that requires an external pull-up resistor. The RESET pin is a TTL compatible CMOS output.

Shutdown

The 16-pin LTC1559 has a TTL compatible input, $\overline{\text{SHDN}}$ that shuts down the whole chip, asserts the $\overline{\text{RESET}}$ and $\overline{\text{RESETE}}$ pins and places the CTL, V_{BAK} and SW pins into high impedance states. The SHDN pin has an internal pull-up of $8\mu\text{A}$ that ensures the chip will not shut down if the pin is left floating. The chip consumes less than $50\mu\text{A}$ during shutdown.

Although there is no $\overline{\text{SHDN}}$ pin for the SO-8 package, the user can shut down the part by pulling CTL to ground. The chip enters "hard" reset leaving only the bandgap and comparators alive. The charger and the boost converter

shut off completely. Note that the backup cell slowly discharges through R_{EXT} in this mode.

Inductor Selection

The LTC1559 is designed to operate with a recommended inductor value of $22\mu\text{H}$ ($\pm 20\%$) with $<0.2\Omega$ DC resistance.

Using inductor values above $22\mu\text{H}$ will deliver more output power but will cause the gas gauge counter to count inaccurately and under-recharge the backup cell. At the same time, the N-channel transistor timer will limit the peak current if the charging time becomes overextended due to the higher inductor value. Using inductor values lower than $22\mu\text{H}$ will degrade the boost converter's maximum output power and cause the gas gauge counter to overcharge the backup cell. Table 3 lists a few recommended surface mount inductor part numbers.

Table 3. Recommended Inductors

MANUFACTURER	PART NUMBER	TYP INDUCTOR VALUE	DCR (Ω)
Sumida	CD54-220	$22\mu\text{H} \pm 20\%$	0.18
Sumida	CDRH73/74	$22\mu\text{H} \pm 20\%$	0.2/0.11

Capacitor Selection

The LTC1559 requires a V_{CC} capacitor of $100\mu\text{F}$ to ensure that boost converter can regulate the output under maximum load conditions. The capacitor's ESR should be small ($<0.2\Omega$) to minimize voltage spikes that might incorrectly trigger the LTC1559's internal V_{CC} comparators. Note that the LTC1559 can usually share the output capacitor with the system regulator. However, a $1\mu\text{F}$ is recommended directly at the LTC1559's V_{CC} pin. The V_{CC} capacitor's ratings like V_{MAX} , $I_{\text{RIPPLE(RMS)}}$ all must meet the system regulator's specifications as well.

Battery Selection

A primary application for the LTC1559 is a "bridging" supply, only providing backup current while the main system battery is being replaced. In these applications, the LTC1559 works well with NiCd button cells or small cylindrical cells, reducing system costs and board space. It is optimized for use with up to 512mAh battery capacities.

APPLICATIONS INFORMATION

The LTC1559 works with standard or memory backup specific NiCd cells. Memory backup cells can operate at higher temperatures and have lower self-discharge rates. The LTC1559's trickle charger is designed to accommodate both memory backup cells (with low self-discharge) and standard cells (with higher self-discharge). Some recommended manufacturers and part numbers are listed in Table 4.

The internal resistance of the backup cell increases power dissipation as the boost converter draws current from it during switching, degrading efficiency. Due to the fixed inductor peak current architecture, the LTC1559's boost converter output power drops significantly when the NiCd cell's internal resistance increases at the end of its charge. The inductor charging time increases due to a larger R/L time constant, decreasing the switching frequency. It is advisable, especially for batteries with high internal resistance, to include a 1 μ F or larger bypass capacitor across the battery to ensure that the boost converter can deliver the maximum output power regardless of the NiCd internal resistance.

Table 4. Button/Cylindrical NiCd 1.2V Cells

MANUFACTURER (TYPE)	PART NUMBER	CAPACITY (mAh)	R _{SERIES} (Ω)
SAFT (Memory Backup)	GB60	60	1.1
	GB170	170	0.4
	GB280	280	0.4
SAFT (Standard)	VB10E	100	0.038
	VB22E	220	0.022
	VB30E	300	0.017
	VB60E	600	0.014
Sanyo (Standard)	N-50AAA	55	0.055
	N-110AA	120	0.03
	N-120TA	130	0.034
	N-150N	170	0.027
	N-200AAA	220	0.021
	N-270AA	305	0.015
	N-500A	500	0.09
Panasonic (Standard)	P-11AA	110	0.08

TYPICAL APPLICATION

LTC1559-3.3 Backup System with an LTC1435 Main System Regulator (LTC1435 Output Sense at the Drain of Q11)

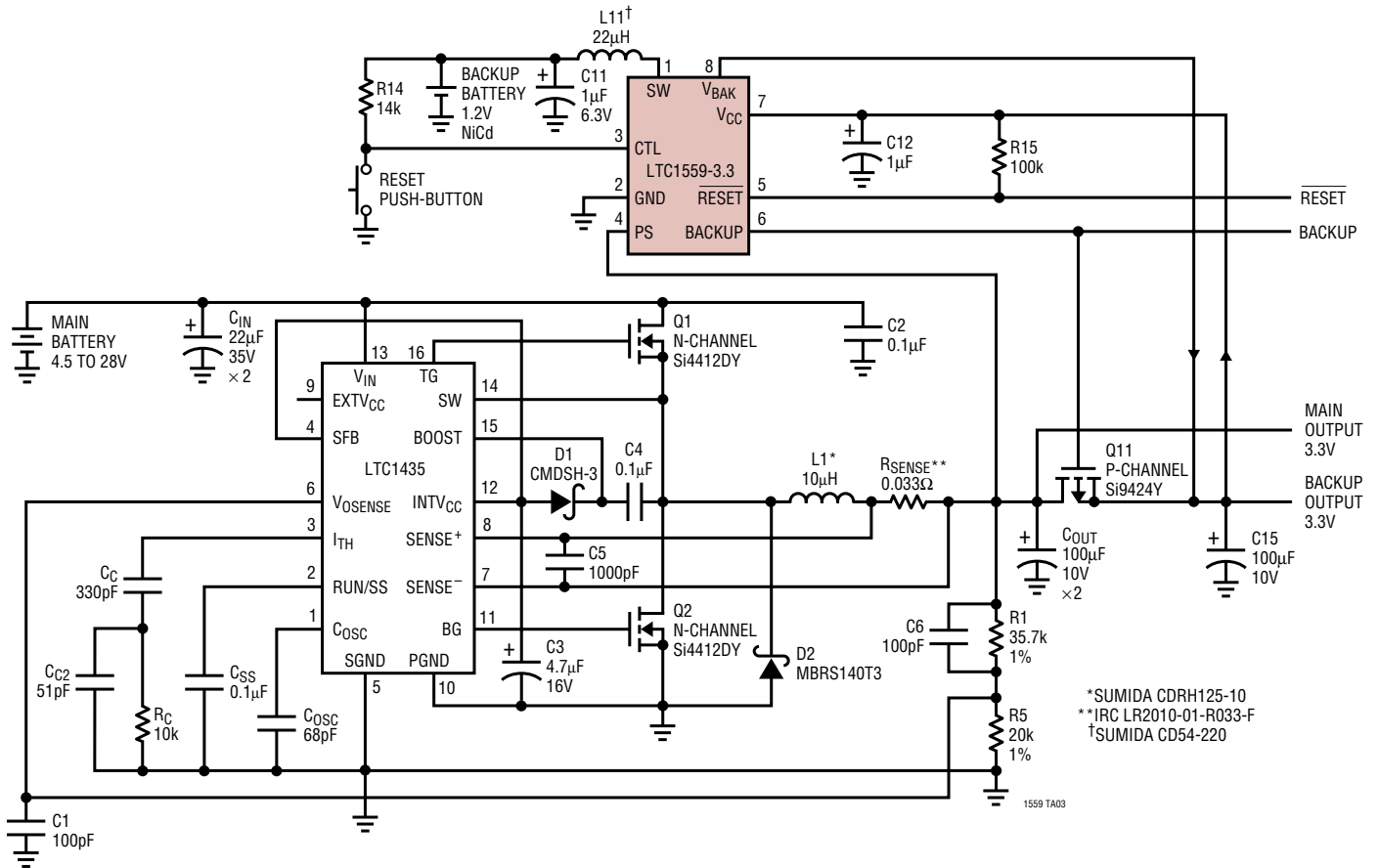

Description

The PS pin connects to Q11's drain and allows the LTC1559 to detect the restoration of the main battery during backup mode. Once the LTC1435's output is greater than V_{OUT}

during backup mode, the LTC1559 deasserts its BACKUP pin and returns control back to the LTC1435. Q11 turns on and allows the LTC1435 to charge C15. Please refer to the Applications Information section for more details.

PACKAGE DESCRIPTION

Dimensions in inches (millimeters) unless otherwise noted.

S8 Package
8-Lead Plastic Small Outline (Narrow 0.150)
 (LTC DWG # 05-08-1610)

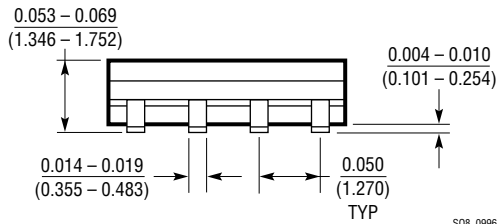
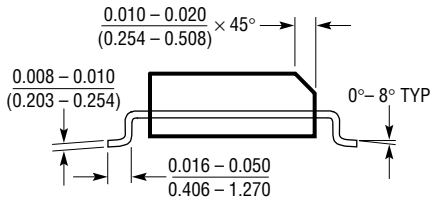
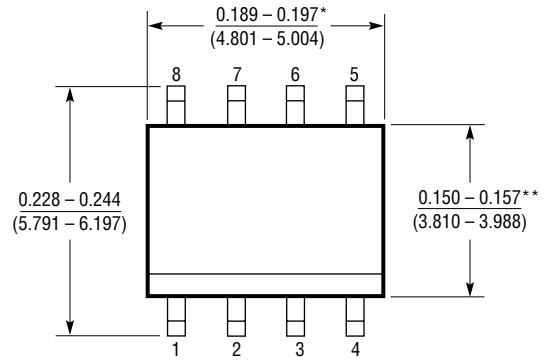

*DIMENSION DOES NOT INCLUDE MOLD FLASH. MOLD FLASH SHALL NOT EXCEED 0.006" (0.152mm) PER SIDE
 **DIMENSION DOES NOT INCLUDE INTERLEAD FLASH. INTERLEAD FLASH SHALL NOT EXCEED 0.010" (0.254mm) PER SIDE

S08 0996

PACKAGE DESCRIPTION

Dimensions in inches (millimeters) unless otherwise noted.

GN Package
16-Lead Plastic SSOP (Narrow 0.150)
 (LTC DWG # 05-08-1641)

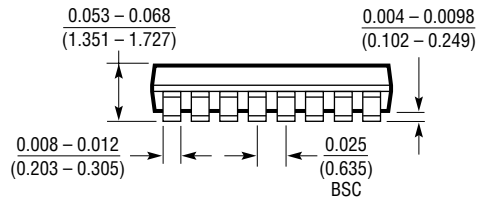
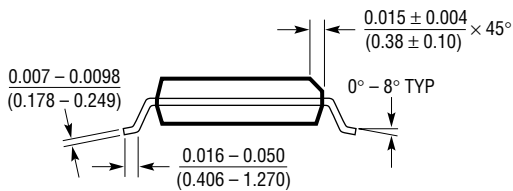
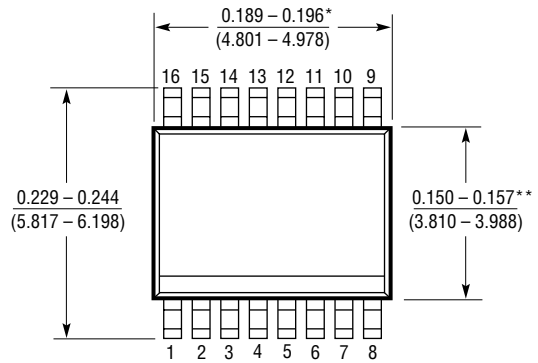

- * DIMENSION DOES NOT INCLUDE MOLD FLASH. MOLD FLASH SHALL NOT EXCEED 0.006" (0.152mm) PER SIDE
- ** DIMENSION DOES NOT INCLUDE INTERLEAD FLASH. INTERLEAD FLASH SHALL NOT EXCEED 0.010" (0.254mm) PER SIDE

GN16 (SSOP) 1197

PACKAGE DESCRIPTION

Dimensions in inches (millimeters) unless otherwise noted.

S Package
16-Lead Plastic Small Outline (Narrow 0.150)
 (LTC DWG # 05-08-1610)

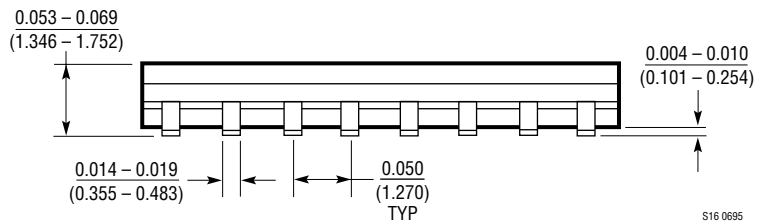
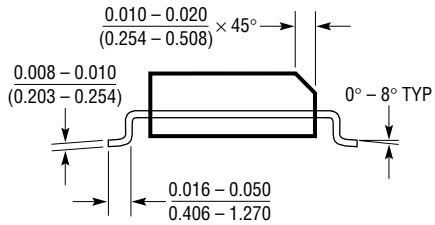
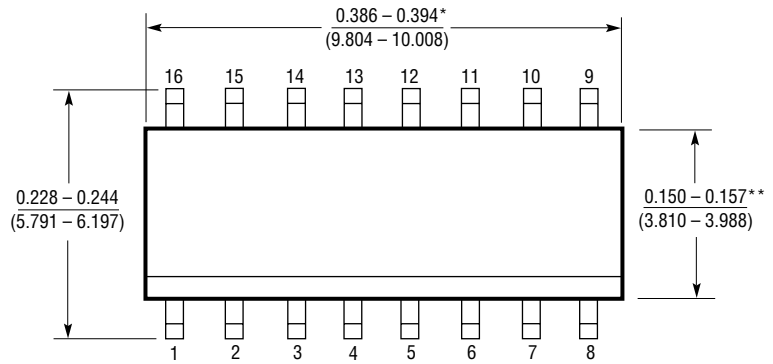

S16 0695

*DIMENSION DOES NOT INCLUDE MOLD FLASH. MOLD FLASH SHALL NOT EXCEED 0.006" (0.152mm) PER SIDE

**DIMENSION DOES NOT INCLUDE INTERLEAD FLASH. INTERLEAD FLASH SHALL NOT EXCEED 0.010" (0.254mm) PER SIDE