

FEATURES

- Micropower Operation
- Single 5V or $\pm 15V$ Supply Operation
- Low Charge Injection
- Low R_{ON}
- Low Leakage
- Guaranteed Break Before Make
- Latch Resistant Design
- TTL/CMOS Compatible
- Improved Second Source for DG201A/DG202

KEY SPECIFICATIONS

- Supply Current $I^+ = 40\mu A, I^- = 5\mu A$ Max
- Charge Injection
 - $\pm 15V$ Supplies $\pm 25pC$ Max
 - Single 5V Supply 2pC Typ
- R_{ON} 65Ω Typ
- Signal Range $\pm 15V$

DESCRIPTION

The LTC[®]201A, LTC202, and LTC203 are micropower, quad CMOS analog switches which typically dissipate only $250\mu W$ from $\pm 15V$ supplies and $40\mu W$ from a single 5V supply. The switches have 65Ω typical on resistance and a very high off resistance. A break-before-make characteristic, inherent in these switches, prevents the shorting of two channels. With a supply voltage of $\pm 15V$, the signal range is $\pm 15V$. These switches have special charge compensation circuitry which greatly reduces charge injection to a maximum of $\pm 25pC$ ($\pm 15V$ supplies).

The LTC201A, LTC202, and LTC203 are designed for applications such as programmable gain amplifiers, analog multiplexers, sample-and-hold circuits, precision charge switching and remote switching. These three devices are differentiated by the type of switch action, as shown in the logic table.

LT, LTC and LT are registered trademarks of Linear Technology Corporation.

TYPICAL APPLICATION

Micropower 100Hz to 1MHz V-to-F Converter

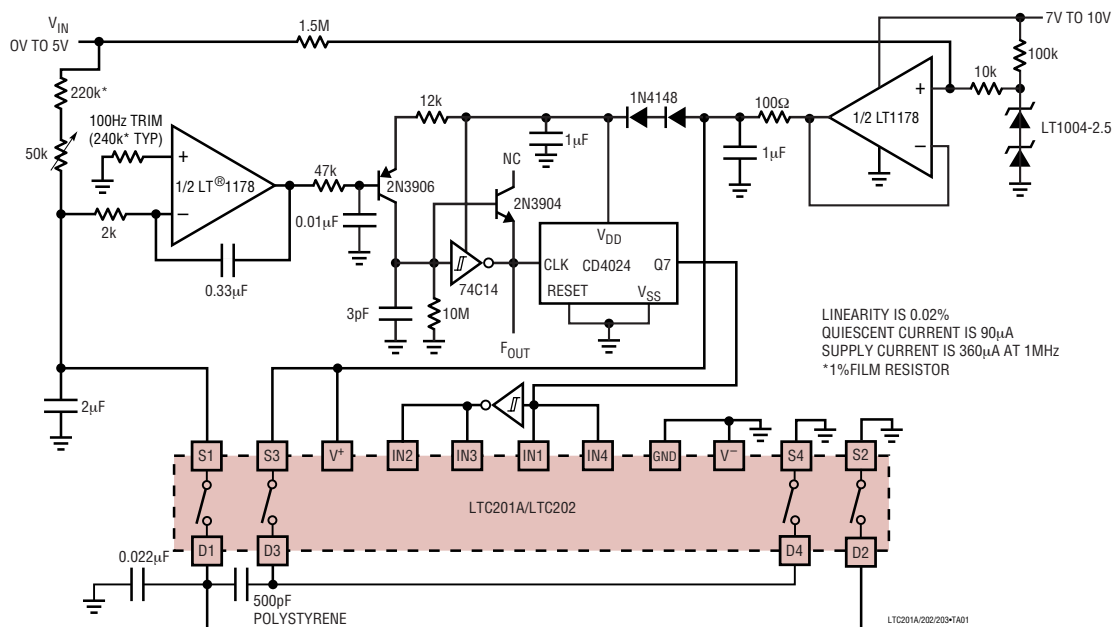

201a23fb

LTC201A/LTC202/LTC203

ABSOLUTE MAXIMUM RATINGS

(Note 1)

Voltages Referenced to V^-

V^+	44V
GND	25V
Digital Inputs, S, D (Note 2)	-2V to ($V^+ + 2V$) or 20mA, Whichever Occurs First

Current

Any Input Except S or D	30mA
Continuous S or D	20mA
Peak S or D (Pulsed at 1ms, 10% Duty Cycle Max)	70mA
ESD Susceptibility (Note 3)	4kV
Power Dissipation (Plastic)	500mW
Power Dissipation (Ceramic)	900mW

Operating Temperature Range

LTC201AC/LTC202C/LTC203C	0°C to 70°C
LTC201AM/LTC202M/LTC203M	-55°C to 125°C

Storage Temperature Range

Lead Temperature (Soldering, 10 sec)

LOGIC TABLE

IN_x	LTC201A	LTC202	LTC203	
	IN1 TO IN4	IN1 TO IN4	IN1, IN4	IN2, IN3
0	ON	OFF	OFF	ON
1	OFF	ON	ON	OFF

PACKAGE/ORDER INFORMATION

<p>TOP VIEW</p> <p>N PACKAGE 16-LEAD PDIP $T_{JMAX} = 110^\circ\text{C}$, $\theta_{JA} = 120\text{C/W}$</p> <p>S PACKAGE 16-LEAD PLASTIC SO $T_{JMAX} = 110^\circ\text{C}$, $\theta_{JA} = 130\text{C/W}$</p> <p>J PACKAGE 16-LEAD CERDIP $T_{JMAX} = 150^\circ\text{C}$, $\theta_{JA} = 100\text{C/W}$</p>	ORDER PART NUMBER
	<p>LTC201ACN</p> <p>LTC201ACS</p> <p>LTC202CN</p> <p>LTC202CS</p> <p>LTC203CN</p> <p>LTC203CS</p>
	ORDER PART NUMBER
	<p>LTC201AMJ</p> <p>LTC201ACJ</p> <p>LTC202MJ</p> <p>LTC202CJ</p> <p>LTC203MJ</p> <p>LTC203CJ</p>

OBSELETE PACKAGE
Consider the N16 or SO-16 Package for Alternate Source

Consult LTC Marketing for parts specified with wider operating temperature ranges.

DIGITAL AND DC ELECTRICAL CHARACTERISTICS

The ● denotes the specifications which apply over full operating temperature range, otherwise specifications are at $T_A = 25^\circ\text{C}$. $V^+ = 15\text{V}$, $V^- = -15\text{V}$, $GND = 0\text{V}$.

PARAMETER	CONDITIONS	LTC201AM/LTC202M/ LTC203M			LTC201AC/LTC202C/ LTC203C			UNITS
		MIN	TYP	MAX	MIN	TYP	MAX	
Analog Signal Range				±15		±15		V
R_{ON}	$V_S = \pm 10\text{V}$ $I_D = 1\text{mA}$	T_{MIN}		110		125		Ω
		25°C		65	110	65	125	Ω
		T_{MAX}		160		160		Ω
ΔR_{ON} vs V_S			20		20		%	
ΔR_{ON} vs Temperature			0.5		0.5		%/°C	
R_{ON} Match	$V_S = 0\text{V}$, $I_{DS} = 1\text{mA}$		5		5		%	
Off Input Leakage I_S (OFF)	$V_D = \pm 14\text{V}$, $V_S = \pm 14\text{V}$ Switch Off		0.01	±1 ±100		0.01	±5 ±100	nA nA

201a23fb

DIGITAL AND DC ELECTRICAL CHARACTERISTICS

The ● denotes the specifications which apply over full operating temperature range, otherwise specifications are at $T_A = 25^\circ\text{C}$. $V^+ = 15\text{V}$, $V^- = -15\text{V}$, $\text{GND} = 0\text{V}$.

PARAMETER	CONDITIONS		LTC201AM/LTC202M/ LTC203M			LTC201AC/LTC202C/ LTC203C			UNITS
			MIN	TYP	MAX	MIN	TYP	MAX	
Off Output Leakage I_D (OFF)	$V_D = \pm 14\text{V}$, $V_S = \pm 14\text{V}$ Switch Off	●		0.01	± 1 ± 100		0.01	± 5 ± 100	nA nA
On Channel Leakage I_D (ON)	$V_D = V_S = \pm 14\text{V}$ Switch On			0.02	± 1		0.02	± 5	nA
		●			± 200			± 200	nA
Input High Voltage V_{INH}		●	2.4			2.4			V
Input Low Voltage V_{INL}		●			0.8			0.8	V
Input High or Low Current I_{INH} and I_{INL}	$V_{IN} = 15\text{V}$, 0V	●			± 1			± 1	μA
C_S (OFF)				5			5		pF
C_D (OFF)				12			12		pF
C_D , C_S (ON)				30			30		pF
I^+	All Logic Inputs Tied Together		16		40		16	40	μA
	$V_{IN} = 0\text{V}$ or 4.0V	●			60			60	μA
I^-				0.1	5		0.1	5	μA
		●			10			10	μA

AC ELECTRICAL CHARACTERISTICS

$V^+ = 15\text{V}$, $V^- = -15\text{V}$, $\text{GND} = 0\text{V}$ unless otherwise noted.

PARAMETER	CONDITIONS		LTC201AM/LTC202M/ LTC203M			LTC201AC/LTC202C/ LTC203C			UNITS
			MIN	TYP	MAX	MIN	TYP	MAX	
t_{ON}	$V_S = 2\text{V}$, $R_L = 1\text{k}\Omega$, $C_L = 35\text{pF}$			290	400		290	400	ns
t_{OFF}				210	300		210	300	ns
t_{OPEN}			20	85		20	85		ns
Off Isolation	$V_S = 2V_{p-p}$, $R_L = 1\text{k}\Omega$, $f = 100\text{kHz}$			75			75		dB
Crosstalk				90			90		dB
Charge Injection O_{INJ}	$R_S = 0\Omega$, $C_L = 1000\text{pF}$, $V_S = 0\text{V}$			5	± 25		8	± 25	pC
Total Harmonic Distortion THD	$V_S = 2V_{p-p}$, $R_L = 10\text{k}\Omega$			0.01			0.01		%

LTC201A/LTC202/LTC203

DIGITAL AND DC ELECTRICAL CHARACTERISTICS

The ● denotes the specifications which apply over full operating temperature range, otherwise specifications are at $T_A = 25^\circ\text{C}$. $V^+ = 5\text{V}$, $V^- = \text{GND} = 0\text{V}$ unless otherwise noted.

PARAMETER	CONDITIONS		LTC201AM/LTC202M/ LTC203M			LTC201AC/LTC202C/ LTC203C			UNITS
			MIN	TYP	MAX	MIN	TYP	MAX	
Analog Signal Range			●	0	5	0	5	V	
R_{ON}	$V_S = \pm 1.5\text{V}, +3\text{V}$ $I_D = 0.25\text{mA}$	T_{MIN}			450		520	Ω	
		25°C		280	450	280	525	Ω	
		T_{MAX}			650		650	Ω	
ΔR_{ON} vs V_S				20		20	%		
ΔR_{ON} vs Temperature				0.5		0.5	$\%/^\circ\text{C}$		
ΔR_{ON} Match	$V_S = 2.5\text{V}, I_{DS} = 0.25\text{mA}$			5		5	%		
Off Input Leakage I_S (OFF)	$V_D = 4\text{V}, 1\text{V}; V_S = 1\text{V}, 4\text{V}$ (Note 4) Switch Off			0.01	± 1	0.01	± 5	nA	
		●			± 100		± 100	nA	
Off Output Leakage I_D (OFF)	$V_D = 4\text{V}, 1\text{V}; V_S = 1\text{V}, 4\text{V}$ (Note 4) Switch Off			0.01	± 1	0.01	+5	nA	
		●			± 100		± 100	nA	
On Channel Leakage I_D (ON)	$V_D = V_S = 1\text{V}, 4\text{V}$ (Note 4) Switch On			0.01	± 1	0.01	± 5	nA	
		●			± 200		± 200	nA	
Input High Voltage V_{INH}			●	2.4		2.4	V		
Input Low Voltage V_{INL}			●		0.8		0.8	V	
Input High or Low Current I_{INH} and I_{INL}	$V_{IN} = 5\text{V}, 0\text{V}$		●		± 1		± 1	μA	
C_S (OFF)				5		5	pF		
C_D (OFF)				12		12	pF		
C_D, C_S (ON)				30		30	pF		
I^+	All Logic Inputs Tied Together $V_{IN} = 0\text{V}$ OR 4.0V			8	20	8	20	μA	
		●			30		30	μA	

AC ELECTRICAL CHARACTERISTICS

$V^+ = 5\text{V}$, $V^- = \text{GND} = 0\text{V}$ unless otherwise noted.

PARAMETER	CONDITIONS	LTC201AM/LTC202M/ LTC203M			LTC201AC/LTC202C/ LTC203C			UNITS
		MIN	TYP	MAX	MIN	TYP	MAX	
t_{ON}	$V_S = 2\text{V}, R_L = 1\text{k}\Omega, C_L = 35\text{pF}$		450	600		450	600	ns
t_{OFF}			190	300		190	300	ns
t_{OPEN}		100	250		100	250	ns	
Off Isolation	$V_S = 2V_{P-P}, R_L = 1\text{k}\Omega, f = 100\text{Hz}$		75			75		dB
Crosstalk			90			90		dB
Charge Injection Q_{INJ}	$R_S = 0\Omega, C_L = 1000\text{pF}, V_S = 2.5\text{V}$		2			2		pC
Total Harmonic Distortion THD	$V_S = 2V_{P-P}, R_L = 10\text{k}\Omega$		0.01			0.01		%

Note 1: Absolute Maximum Ratings are those values beyond which the life of a device may be impaired.

Note 2: Signals on S, D, or IN exceeding V^+ or V^- will be clamped by internal diodes. Limit forward diode current to maximum current rating.

Note 3: In-circuit ESD on the switch pins (S or D) exceeds 4kV (see test circuit).

Note 4: Leakage current with a single 5V supply is guaranteed by correlation with the $\pm 15\text{V}$ leakage current.

TYPICAL PERFORMANCE CHARACTERISTICS

R_{ON} vs V_S Over Supply Voltage

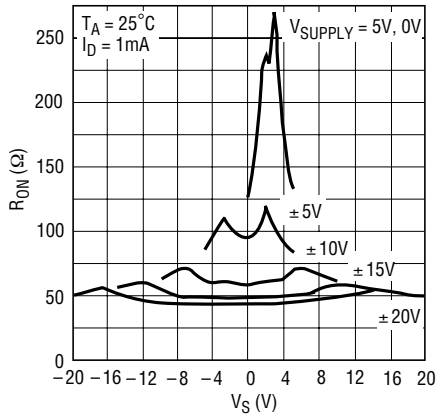

LT201_202_203 • TPC01

R_{ON} vs V_S Over Temperature

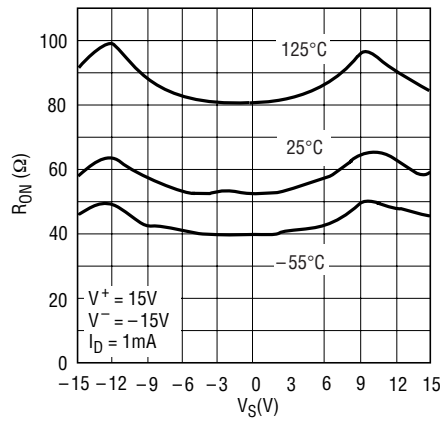

LT201_202_203 • TPC02

R_{ON} vs V_S Over Temperature

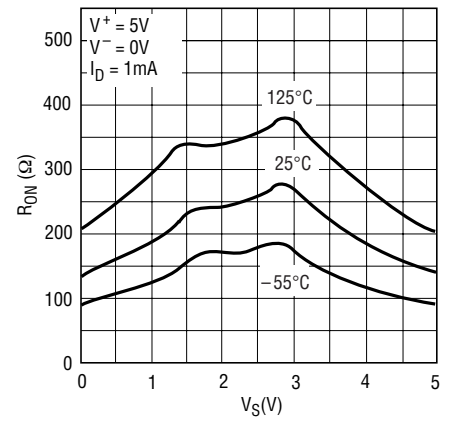

LT201_202_203 • TPC03

Q_{INJ} vs V_S Over Supply Voltage

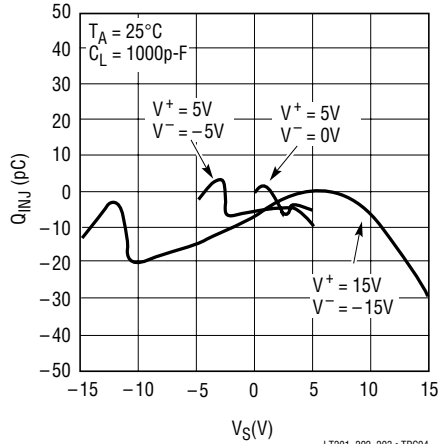

LT201_202_203 • TPC04

Positive Supply Current vs Logic Input Voltage

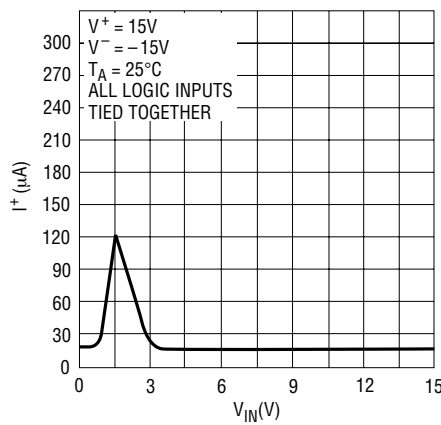

LT201_202_203 • TPC05

Supply Current vs Logic Input Voltage

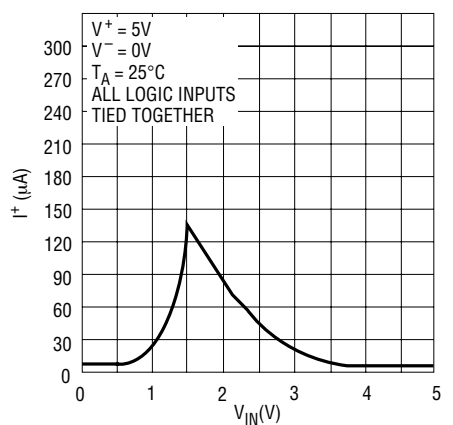

LT201_202_203 • TPC06

APPLICATIONS INFORMATION

Switching Time Test Circuit

Switch output waveform shown for $V_S = \text{constant}$ with logic input waveform as shown. Note that V_S may be + or – as per switching time test circuit. V_O is the steady state

output switch on. Feedthrough via gate capacitance may result in spikes at leading and trailing edge of output waveform.

Switching Time Test Circuit

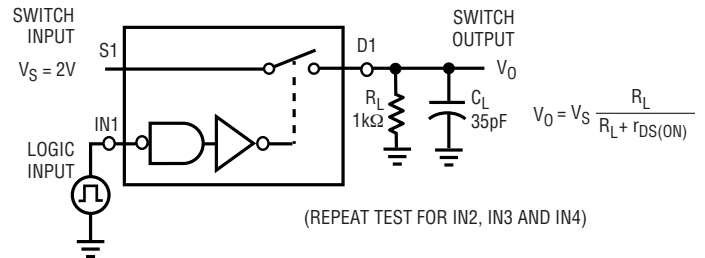
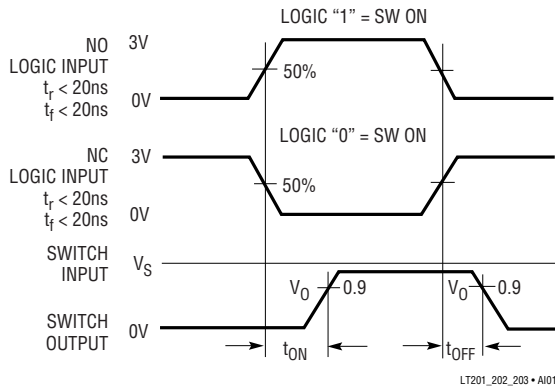

Charge Injection Test Circuit

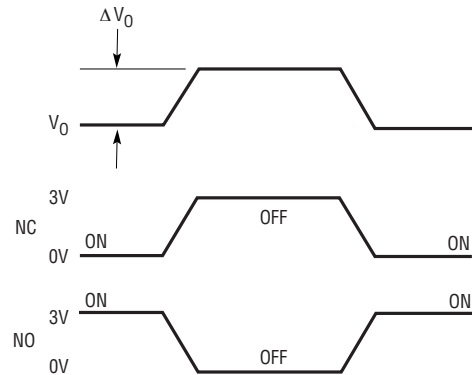
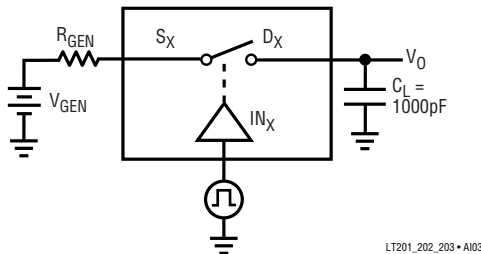

ΔV_O IS THE MEASURED VOLTAGE ERROR DUE TO CHARGE INJECTION.
THE ERROR VOLTAGE IN COULOMBS IS $\Delta Q = C_L \cdot \Delta V_O$

LT201_202_203 • A104

APPLICATIONS INFORMATION

OIRR-Off Isolation Test Circuit

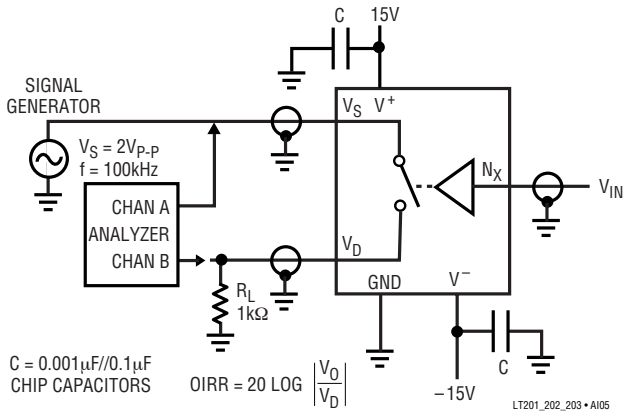

V_{IN}	
3V	NC
0V	NO

CCRR-Channel to Channel Crosstalk Test Circuit

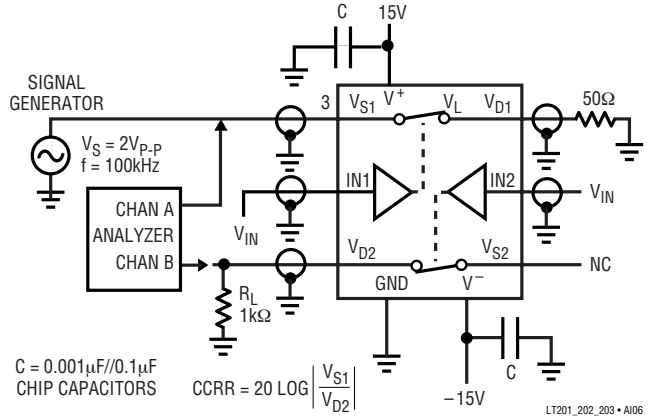

V_{IN}	
3V	NC
0V	NO

In-Circuit ESD Test Circuit

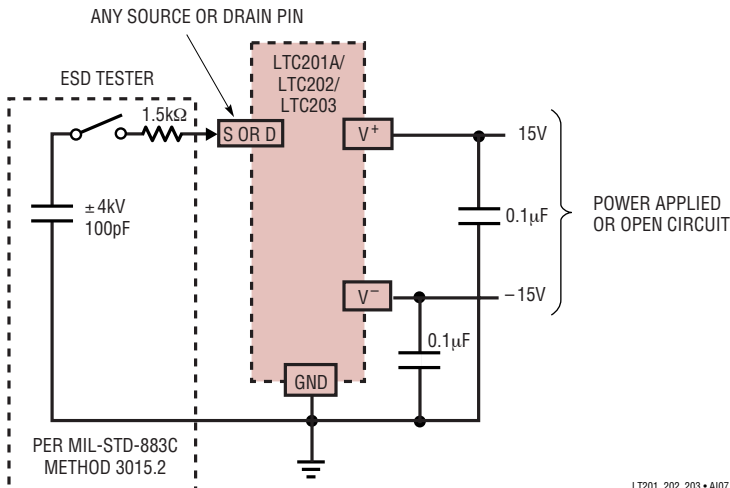

Micropower, 4.5V to 15V Input, Voltage Doubler Using the LTC203

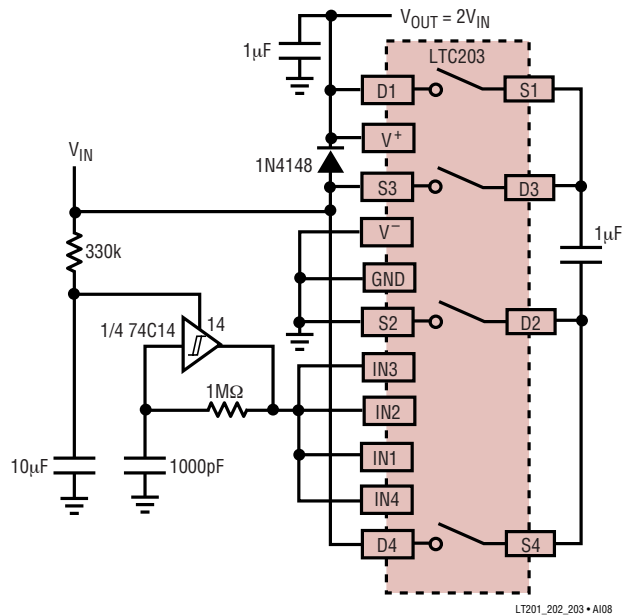

V_{IN}	I_Q	$V_{OUT}, \text{ NO LOAD}$	R_{OUT}
4.5V	20μA	8.988V(12mV Error)	1.2k
15V	130μA	29.96V(40mV Error)	600Ω

APPLICATIONS INFORMATION

Micropower, $\pm 4.5V$ to $\pm 15V$, Voltage Inverter Using the LTC203

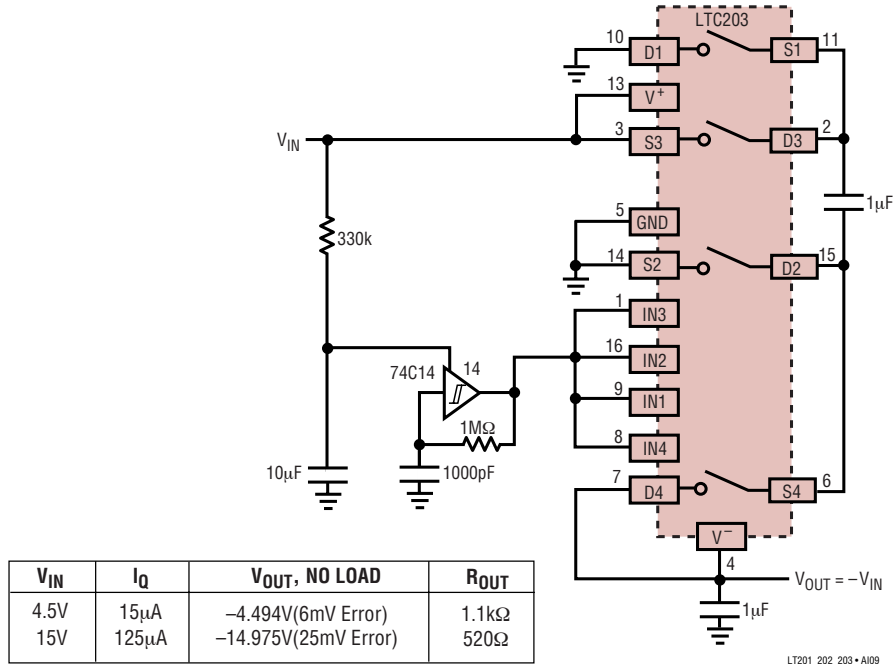

Quad 12-Bit Sample-and-Hold

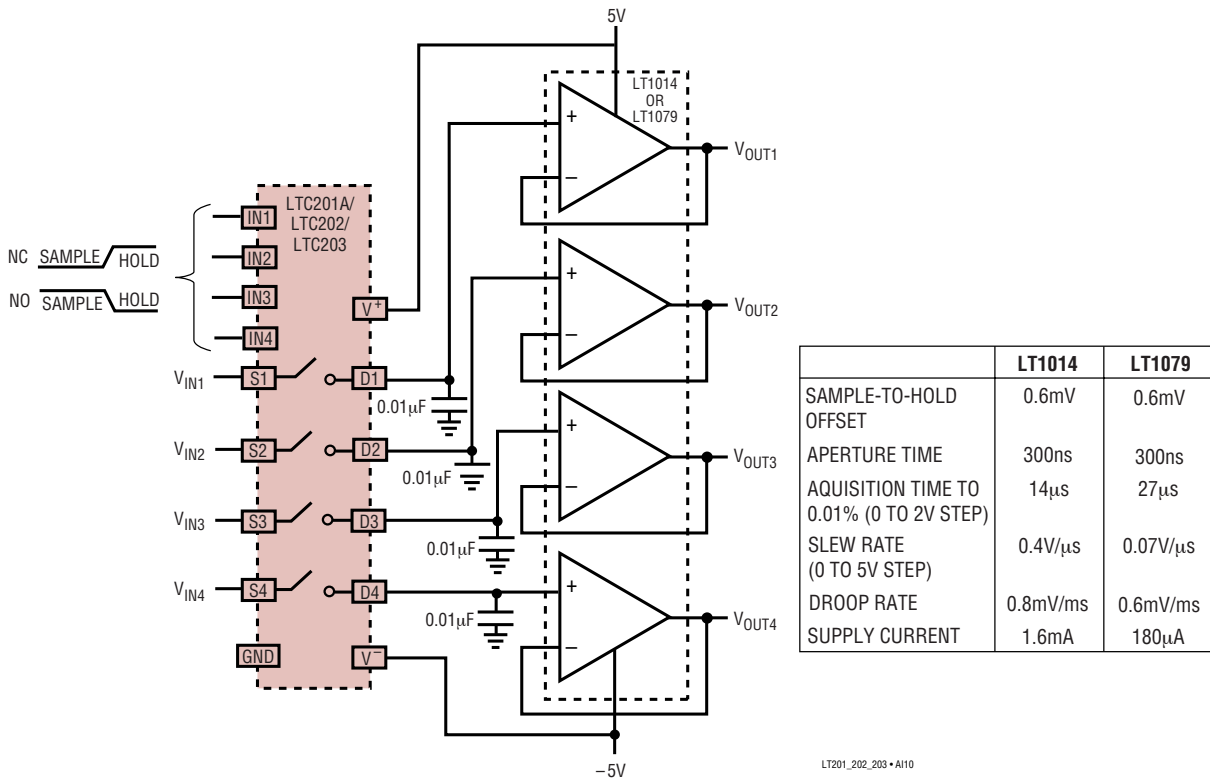

APPLICATIONS INFORMATION

Ultra Low Noise, Low Drift Chopper Amplifier

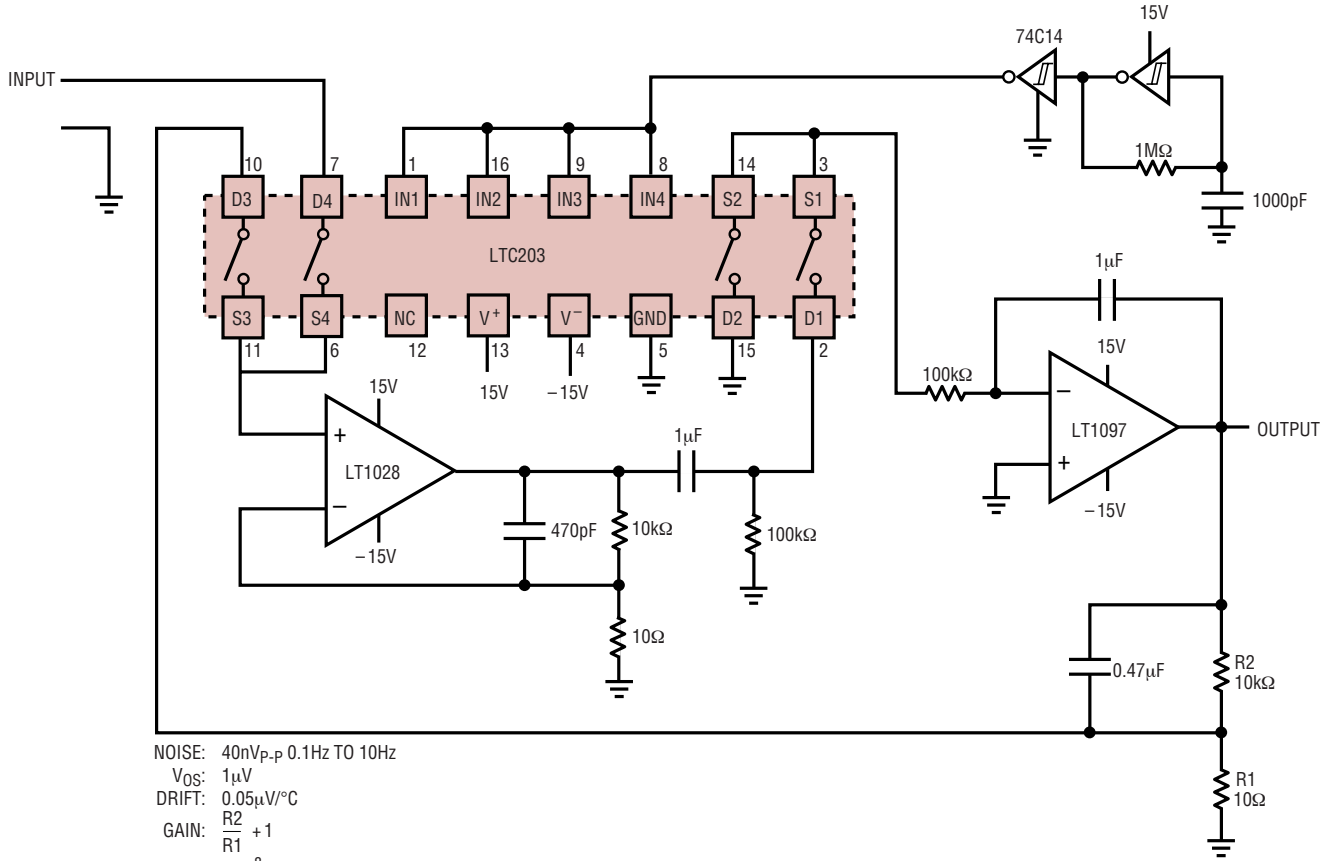

LT201_202_203 • AI11

Noise in a 0.1 to 10Hz Bandwidth

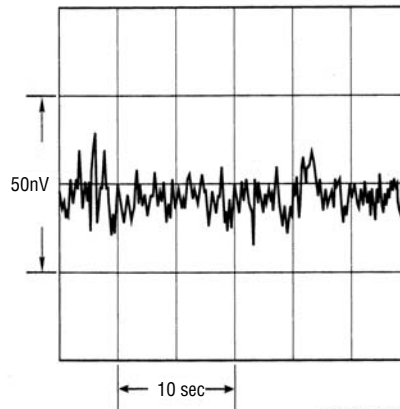

LTC201A/202/203 • AI12

APPLICATIONS INFORMATION

Bipolar (AC) Input V/F Converter

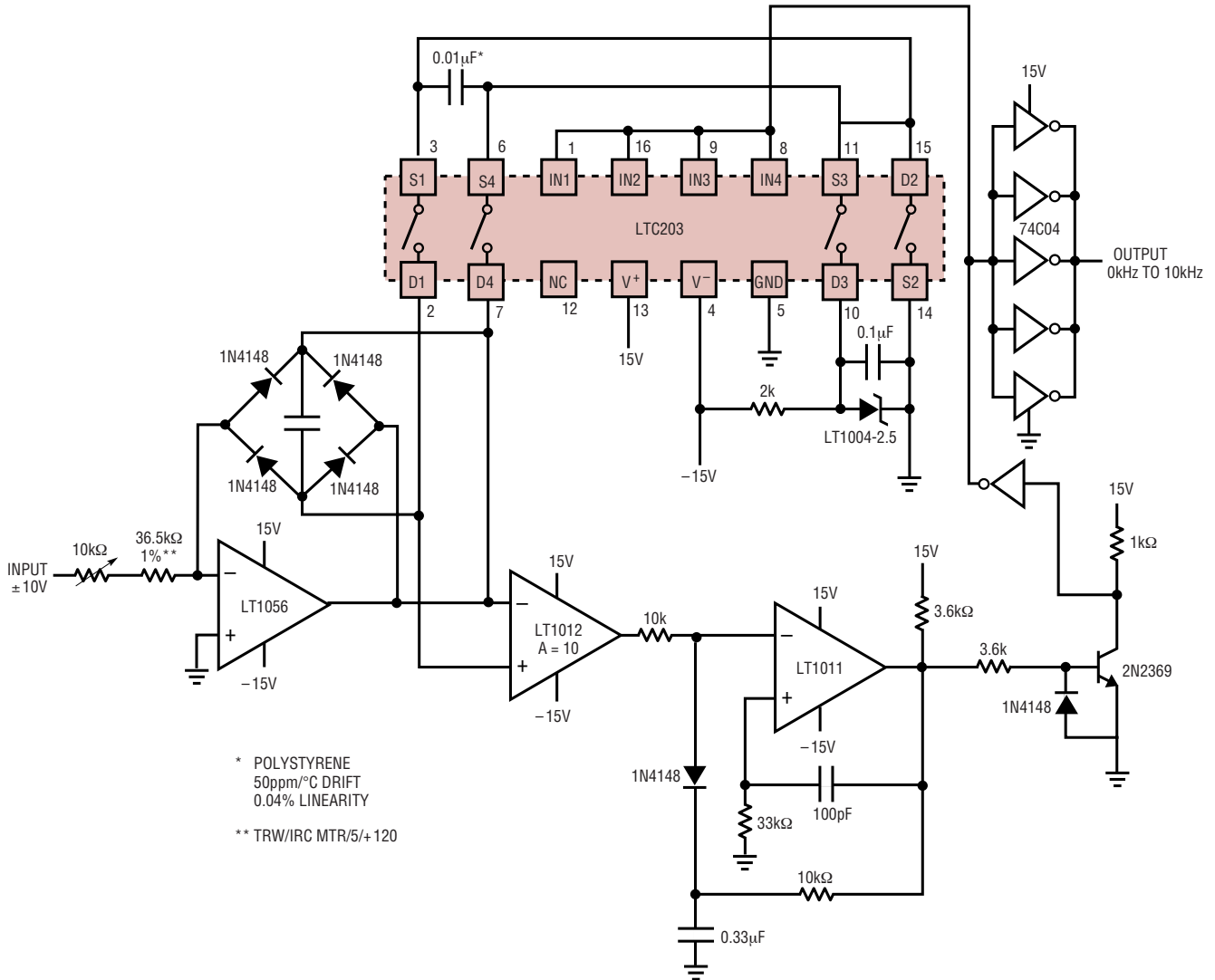

LT201_202_203 • A113

APPLICATIONS INFORMATION

Micropower Thermocouple Temperature to Frequency Converter

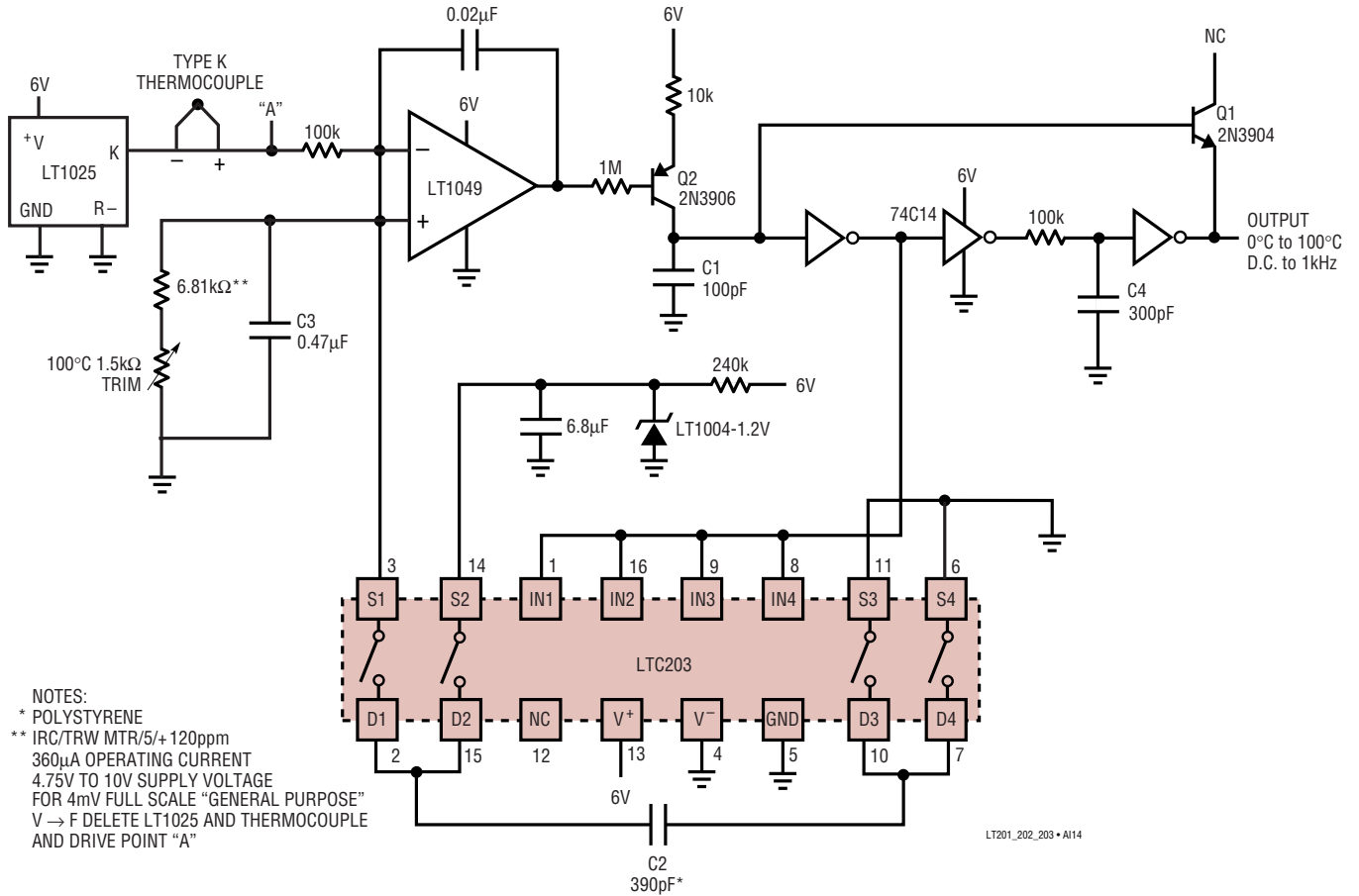

NOTES:
 * POLYSTYRENE
 ** IRC/TRW MTR/5/+ 120ppm
 360µA OPERATING CURRENT
 4.75V TO 10V SUPPLY VOLTAGE
 FOR 4mV FULL SCALE "GENERAL PURPOSE"
 V → F DELETE LT1025 AND THERMOCOUPLE
 AND DRIVE POINT "A"

LT201_202_203 • A114

APPLICATIONS INFORMATION

Precision Current Sensing in Supply Rails

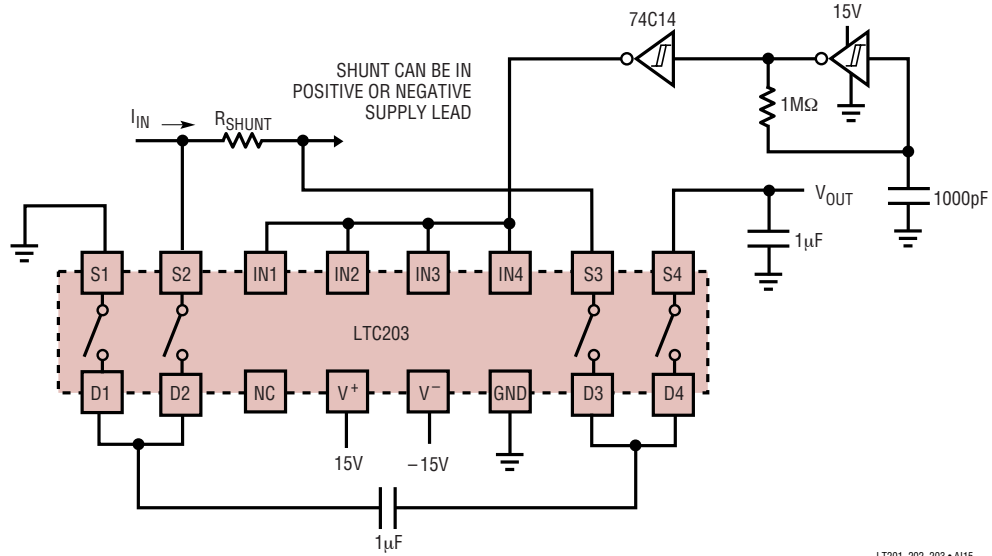

Precision Voltage Divide by 2 Circuit

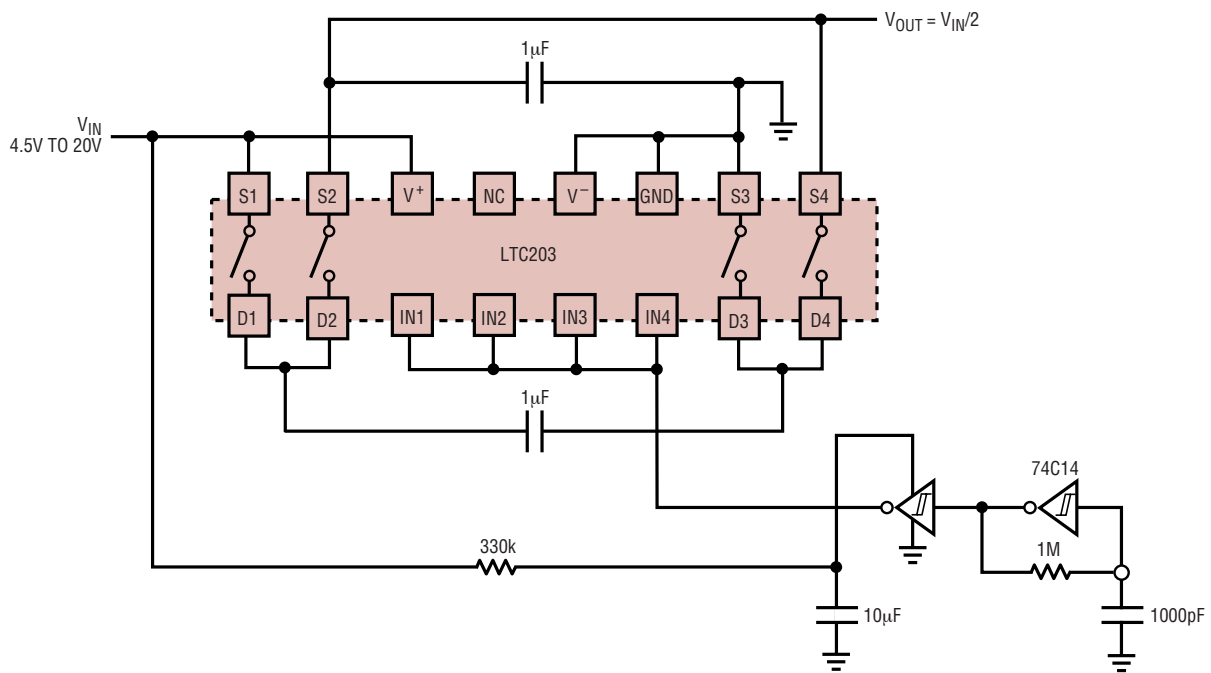

PACKAGE DESCRIPTION

J Package
16-Lead CERDIP (Narrow .300 Inch, Hermetic)
 (Reference LTC DWG # 05-08-1110)

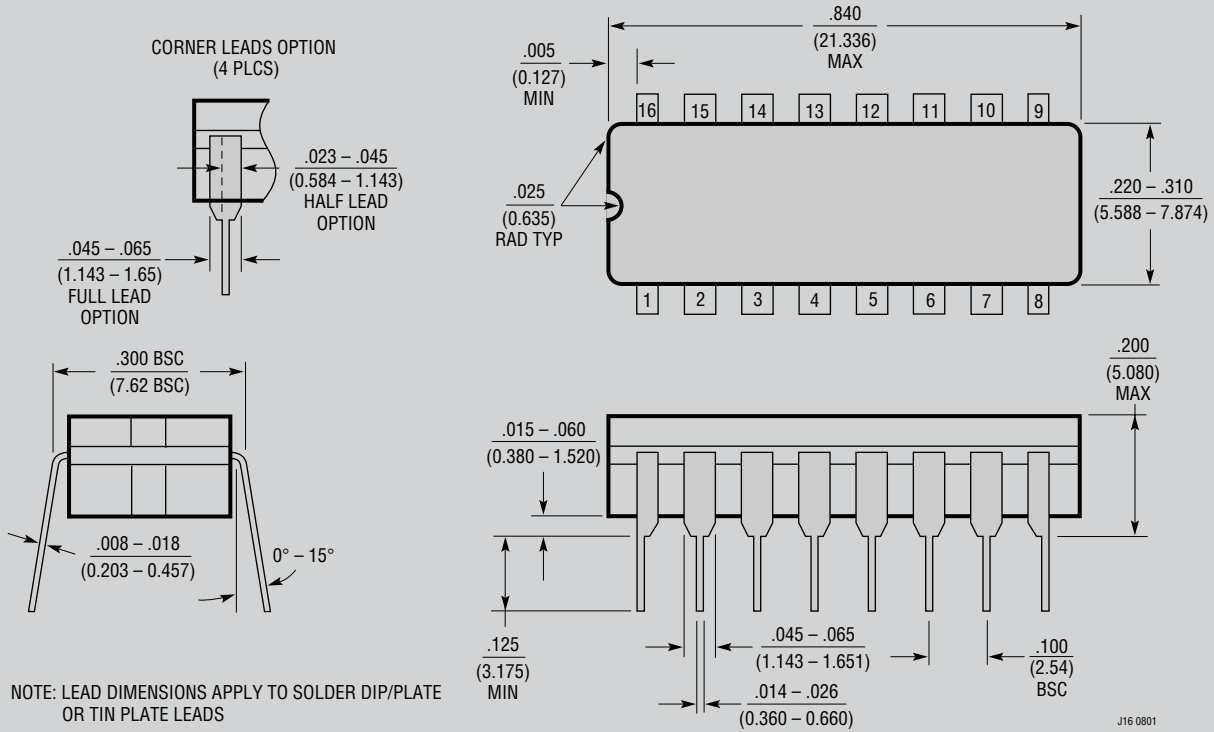

OBSOLETE PACKAGE

PACKAGE DESCRIPTION

N Package
16-Lead PDIP (Narrow .300 Inch)
 (Reference LTC DWG # 05-08-1510)

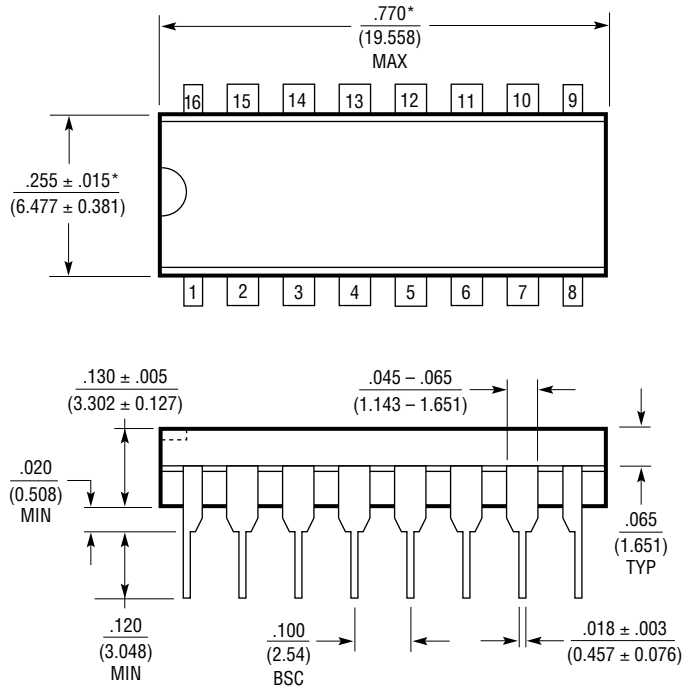

NOTE:
 1. DIMENSIONS ARE $\frac{\text{INCHES}}{\text{MILLIMETERS}}$

*THESE DIMENSIONS DO NOT INCLUDE MOLD FLASH OR PROTRUSIONS.
 MOLD FLASH OR PROTRUSIONS SHALL NOT EXCEED .010 INCH (0.254mm)

N16 1002

PACKAGE DESCRIPTION

S Package 16-Lead Plastic Small Outline (Narrow .150 Inch) (Reference LTC DWG # 05-08-1610)

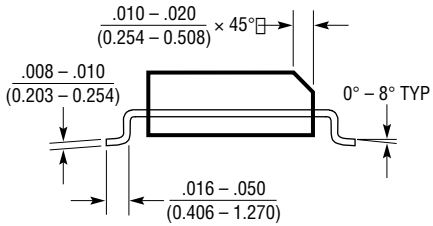
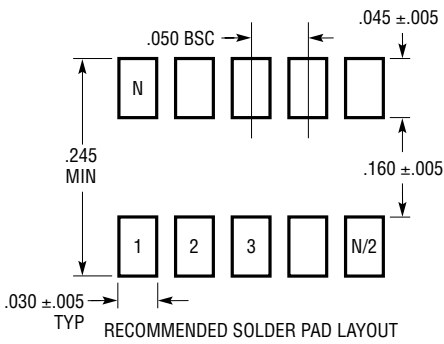

- NOTE:
 1. DIMENSIONS IN $\frac{\text{INCHES}}{\text{(MILLIMETERS)}}$
 2. DRAWING NOT TO SCALE
 3. THESE DIMENSIONS DO NOT INCLUDE MOLD FLASH OR PROTRUSIONS.
 MOLD FLASH OR PROTRUSIONS SHALL NOT EXCEED .006" (0.15mm)

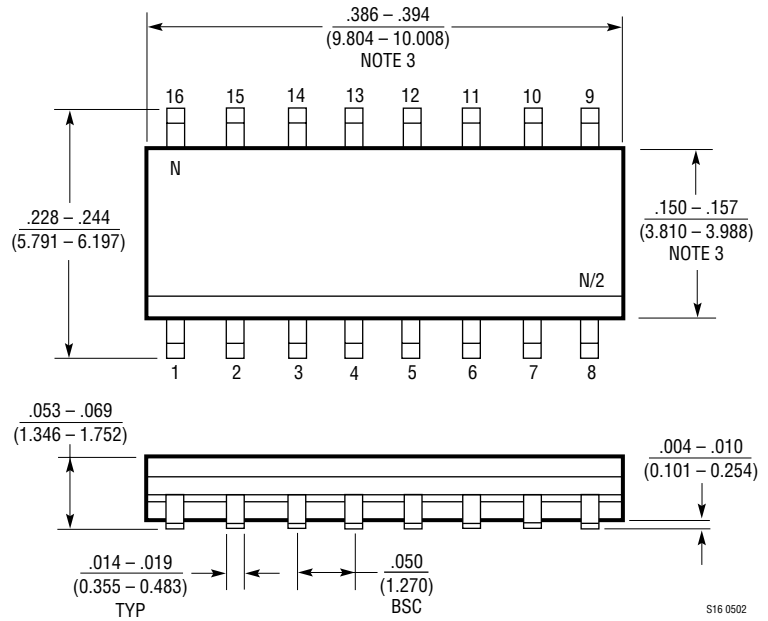

S16 0502