

Ultra-Low Voltage Energy Harvester and Primary Battery Life Extender

FEATURES

- Thermal Energy Harvesting Assisted Power Management System
 - V_{OUT} Tracks the Primary Battery Voltage
 - 2.2V LDO Output
 - Reserve Energy Output, Clamped to 4.3V
- Operates from Inputs as Low as 20mV
- Battery In-Use Indicator (BAT_OFF)
- I_Q from Battery:
 - 80nA When Energy Harvesting
 - 6 μ A No Energy Harvesting
- Standard, Compact Step-Up Transformer
- Small, Thermally Enhanced 10-lead (3mm \times 3mm) DFN package

APPLICATIONS

- Industrial Wireless Sensing
- Remote Sensor and Radio power
- HVAC
- Automatic Metering
- Building Automation, Security
- Predictive Maintenance, Condition Monitoring

DESCRIPTION

The **LTC[®]3107** is a highly integrated DC/DC converter designed to extend the life of a primary battery in low power wireless systems by harvesting and managing surplus energy from extremely low input voltage sources such as TEGs (Thermoelectric Generators) and thermopiles. The step-up topology operates from input voltages as low as 20mV.

Using a small step-up transformer, the LTC3107 provides a complete power management solution for typical wireless sensor applications that operate from a primary battery. The 2.2V LDO can be used to power an external microprocessor, while the main output voltage automatically adapts to match the voltage of the primary battery. The LTC3107 seamlessly transitions from battery power to harvested power whenever harvested energy is available, extending the life of the battery. The BAT_OFF indicator can be used to track battery usage. An optional storage capacitor accumulates excess harvested energy, further extending battery life.

The LTC3107 is available in a small, thermally enhanced 10-lead (3mm \times 3mm) DFN package.

LT, LT, LTC, LTM, Linear Technology and the Linear logo are registered trademarks and VLDO is a trademark of Linear Technology Corporation. All other trademarks are the property of their respective owners.

TYPICAL APPLICATION

TEG Powered Thermal Harvester with Primary Cell Life Extender

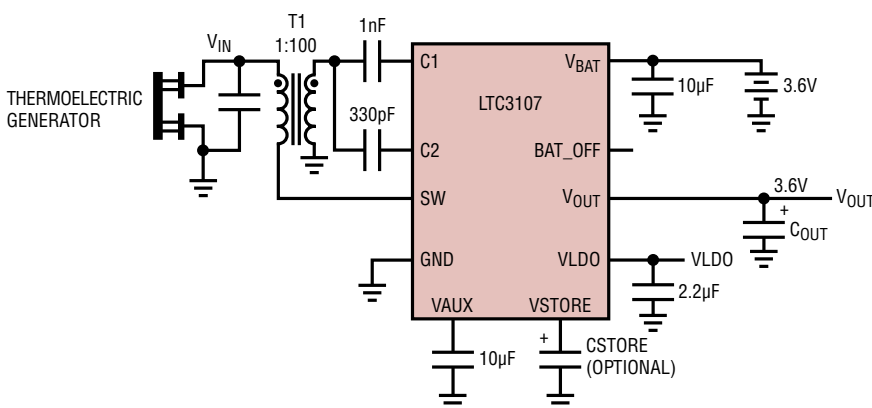

3107 TA01a

Percentage of Added Battery Life vs TEG Surface Temperature

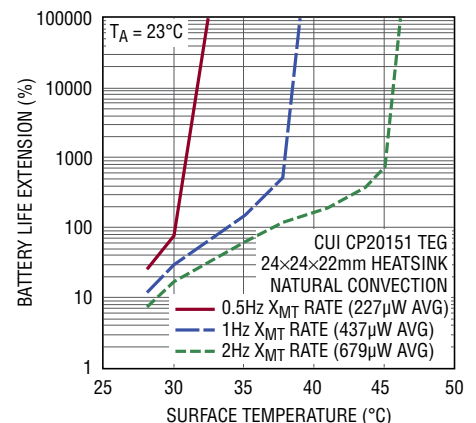

3107 TA01

LTC3107

ABSOLUTE MAXIMUM RATINGS

(Note 1)

SW Voltage	-0.3V to 2V
C1 Voltage (Note 5).....	-0.3V to (VAUX+0.6V)
C2 Voltage (Note 5).....	-8V to 8V
VAUX.....	15mA into VAUX
V _{BAT} , VSTORE	-0.3V to 4.5V
V _{OUT} , BAT_OFF	-0.3V to 4.5V
VLDO	-0.3V to 4.5V
Operating Junction Temperature Range (Note 2)	-40°C to 125°C
Storage Temperature Range	-65°C to 150°C

PIN CONFIGURATION

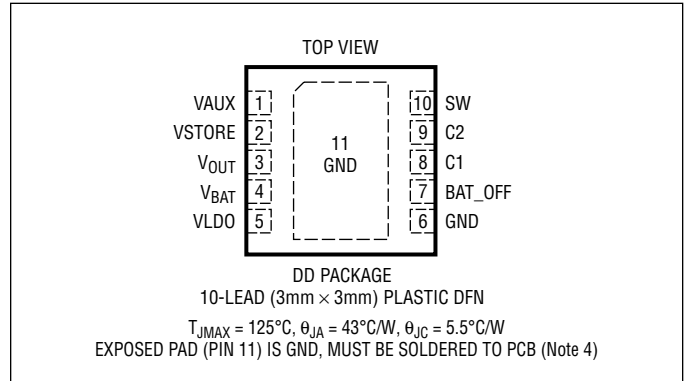

ORDER INFORMATION

LEAD FREE FINISH	TAPE AND REEL	PART MARKING*	PACKAGE DESCRIPTION	TEMPERATURE RANGE
LTC3107EDD#PBF	LTC3107EDD#TRPBF	LGMD	10-Lead (3mm × 3mm) Plastic DFN	-40°C to 125°C
LTC3107IDD#PBF	LTC3107IDD#TRPBF	LGMD	10-Lead (3mm × 3mm) Plastic DFN	-40°C to 125°C

Consult LTC Marketing for parts specified with wider operating temperature ranges. *The temperature grade is identified by a label on the shipping container.

For more information on lead free part marking, go to: <http://www.linear.com/leadfree/>

For more information on tape and reel specifications, go to: <http://www.linear.com/tapeandreeel/>

ELECTRICAL CHARACTERISTICS

The ● denotes the specifications which apply over the specified operating junction temperature range, otherwise specifications are at $T_A = 25^\circ\text{C}$ (Note 2). $V_{AUX} = 4\text{V}$, $V_{BAT} = 3.6\text{V}$ unless otherwise noted.

PARAMETER	CONDITIONS	MIN	TYP	MAX	UNITS
Minimum Harvester Start-Up Voltage	Using 1:100 Transformer Turns Ratio		20	30	mV
Harvester No-Load Input Current	Using 1:100 Transformer Turns Ratio, $V_{IN} = 20\text{mV}$, All Outputs Charged and in Regulation		3	5	mA
Harvester Input Voltage Range	Using 1:100 Transformer Turns Ratio	● $V_{STARTUP}$		500	mV
V_{BAT} Voltage Range		● 2.0		4.0	V
V_{BAT} Current Limit	$V_{OUT} = 0\text{V}$, $V_{AUX} = 0\text{V}$ (Battery Insertion)	● 2	30	60	mA
	$V_{OUT} = (V_{BAT} - 0.4\text{V})$	● 30	70	100	mA
V_{BAT} Quiescent Current	$V_{AUX} > V_{BAT}$ (Harvesting)		80	110	nA
	$V_{AUX} < V_{BAT}$ (Not Harvesting)		6	7.5	μA
V_{BAT} Reverse Current	$V_{AUX} = 4\text{V}$, $V_{BAT} = 2.0\text{V}$			0	nA
V_{OUT} Voltage (Average)	$V_{AUX} > V_{BAT}$ (Harvesting), Relative to V_{BAT} $C_{OUT} \geq 47\mu\text{F}$	● -70	-30	-15	mV
	$V_{AUX} < V_{BAT}$ (Not Harvesting), Relative to V_{BAT} $C_{OUT} \geq 47\mu\text{F}$	● -270	-220	-140	mV
LDO Output Voltage	0.5mA Load	● 2.134	2.2	2.266	V
LDO Load Regulation	$I_{VLDO} = 0\text{mA}$ to 2mA		0.8	1.5	%
LDO Line Regulation	For V_{OUT} from 2.5V to 4V		0.1	0.2	%
LDO Dropout Voltage	$I_{VLDO} = 2\text{mA}$	●	100	200	mV
LDO Current Limit	$V_{LDO} = 0\text{V}$	● 10	20	40	mA
V_{AUX}/V_{STORE} Clamp Voltage	Current Into $V_{AUX} = 1\text{mA}$	● 4.13	4.3	4.48	V
V_{OUT} Quiescent Current	$V_{AUX} > V_{OUT} > V_{BAT}$		10	100	nA
V_{STORE} Leakage Current	$V_{STORE} = 4\text{V}$, $V_{AUX} > V_{STORE}$		10	100	nA
V_{STORE} to V_{OUT} Discharge Path Resistance	$V_{STORE} = 4\text{V}$ $V_{OUT} < V_{BAT} - 60\text{mV}$		120	200	Ω
BAT_OFF Threshold (Falling)	Measured on V_{OUT} Relative to V_{BAT}	-280	-230	-180	mV
BAT_OFF Threshold (Rising)	Measured on V_{OUT} Relative to V_{BAT}	-60	-30	-15	mV
BAT_OFF V_{OL}	Sink Current = 100 μA		0.15	0.2	V
BAT_OFF V_{OH}	Source Current = 0		V_{OUT}		V
BAT_OFF Pull-Up Resistance		0.6	1	1.4	$\text{M}\Omega$
N-Channel MOSFET On-Resistance	$C2 = 5\text{V}$ (Note 3)		0.5		Ω

Note 1: Stresses beyond those listed under Absolute Maximum Ratings may cause permanent damage to the device. Exposure to any Absolute Maximum Rating condition for extended periods may affect device reliability and lifetime.

Note 2: The LTC3107 is tested under pulsed load conditions such that $T_J \approx T_A$. The LTC3107E is guaranteed to meet specifications from 0°C to 85°C junction temperature. Specifications over the -40°C to 125°C operating junction temperature range are assured by design, characterization and correlation with statistical process controls. The LTC3107I is guaranteed over the full -40°C to 125°C operating junction temperature range. Note that the maximum ambient temperature consistent with these specifications, is determined by specific operating conditions in conjunction with board layout, the rated thermal package thermal resistance and other environmental factors. The junction temperature (T_J)

is calculated from the ambient temperature (T_A) and power dissipation (P_D) according to the formula: $T_J = T_A + (P_D \cdot \theta_{JA}^\circ\text{C}/\text{W})$, where θ_{JA} is the package thermal impedance.

Note 3: Specification is guaranteed by design and not 100% tested in production.

Note 4: Failure to solder the exposed backside of the package to the PC board ground plane will result in a thermal resistance much higher than $43^\circ\text{C}/\text{W}$.

Note 5: The Absolute Maximum Rating is a DC rating. Under certain conditions in the applications shown, the peak AC voltage on the C1 and C2 pins may exceed their Absolute Maximum Rating. This behavior is normal and acceptable because the current into the pin is limited by the impedance of the coupling capacitor.

TYPICAL PERFORMANCE CHARACTERISTICS $T_A = 25^\circ\text{C}$, unless otherwise noted.

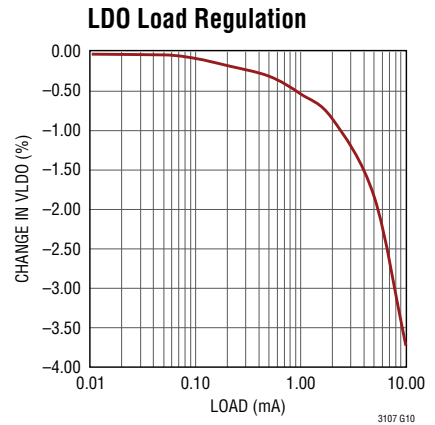
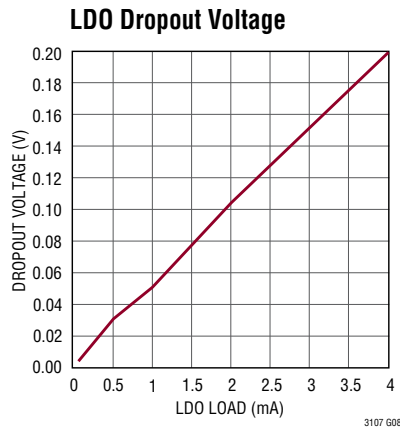
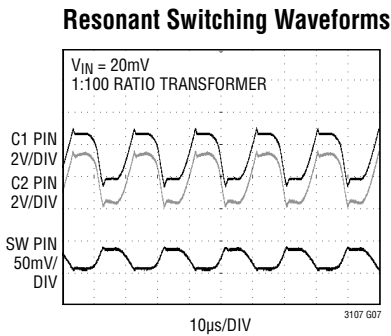
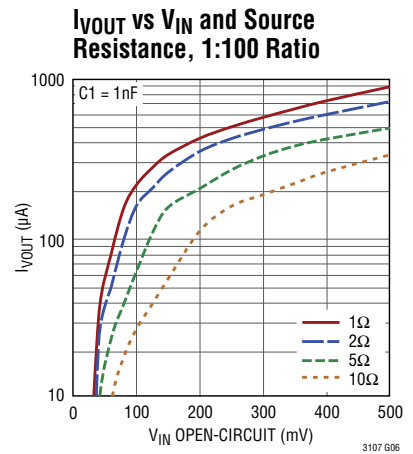
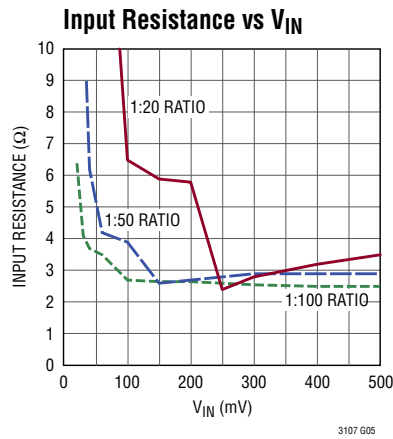
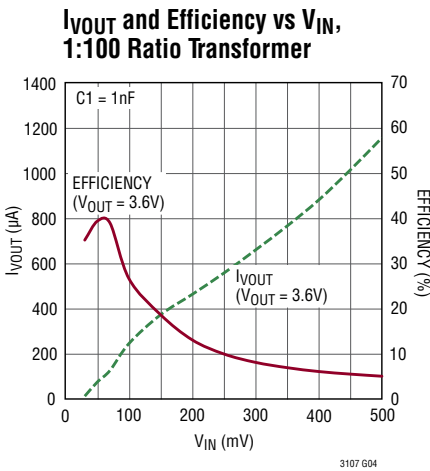
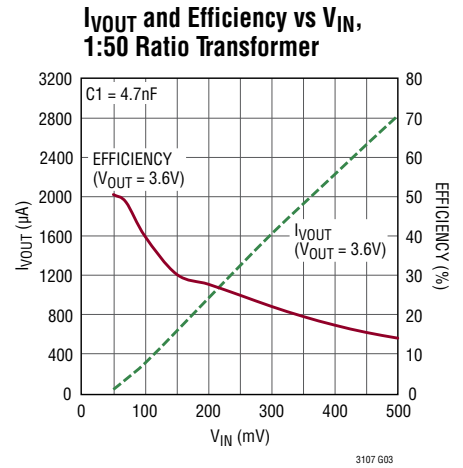
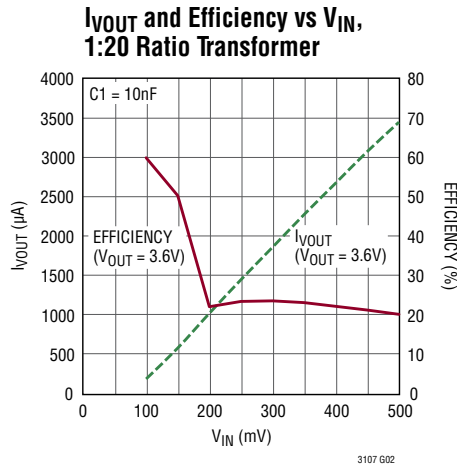
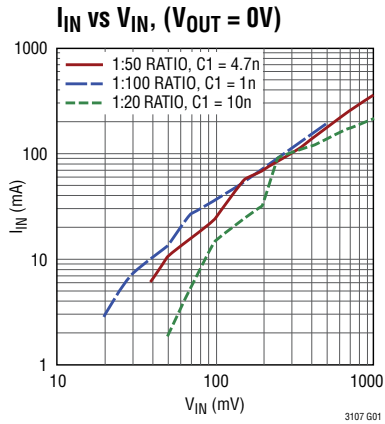

TYPICAL PERFORMANCE CHARACTERISTICS $T_A = 25^\circ\text{C}$, unless otherwise noted.

VAUX Voltage vs Clamp Current

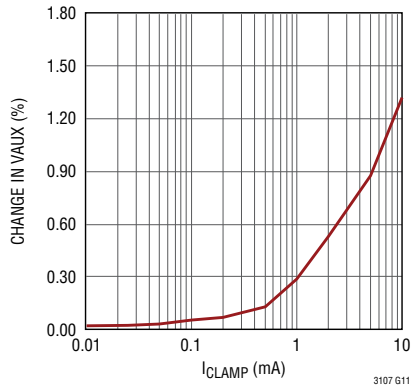

I_{VOUT} Current Limit vs V_{OUT}

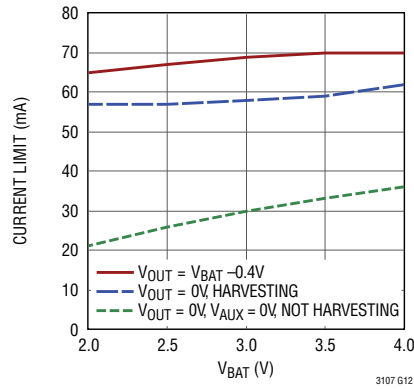

LDO Step Load Response (10 μA to 10mA)

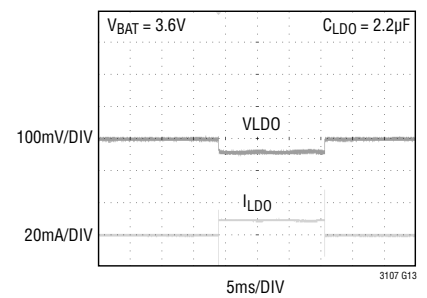

Pulsed V_{OUT} Load, No Harvesting

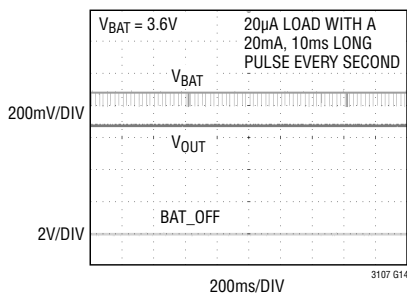

Pulsed V_{OUT} Load, Harvesting (Not Using Battery)

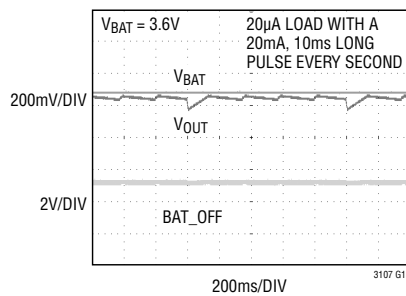

Pulsed V_{OUT} Load, Harvesting Insufficient C_{OUT} or Insufficient Harvested Energy

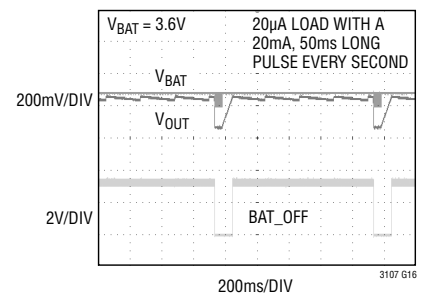

Voltage Sequencing When Battery Is Connected

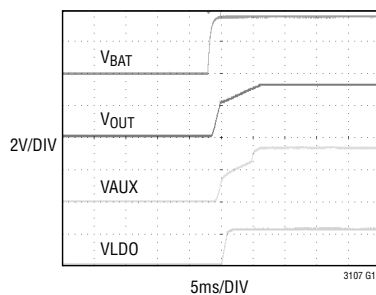

TYPICAL PERFORMANCE CHARACTERISTICS $T_A = 25^\circ\text{C}$, unless otherwise noted.

Voltage Sequencing While Harvester Is Turned On and Off

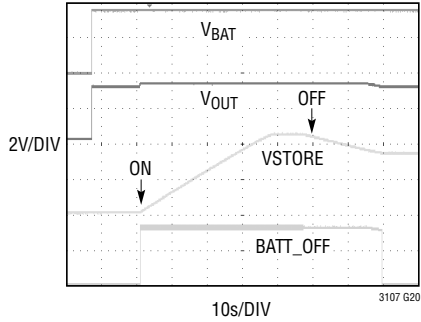

V_{OUT} Transitioning Between Harvester and Battery Power

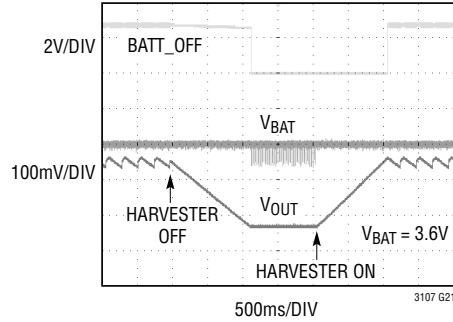

**V_{STORE} Holding-Up V_{OUT}
($V_{BAT} = 3\text{V}$, $C_{STORE} = 1300\mu\text{F}$,
 $I_{OUT} = 50\mu\text{A}$, Holdup = 37 SEC)**

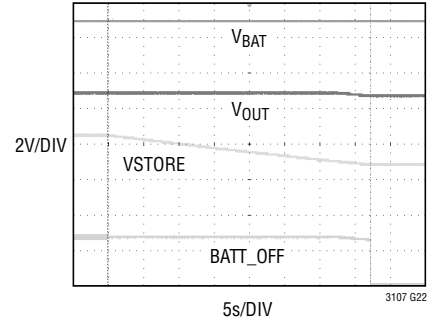

V_{OUT} Ripple While Harvesting

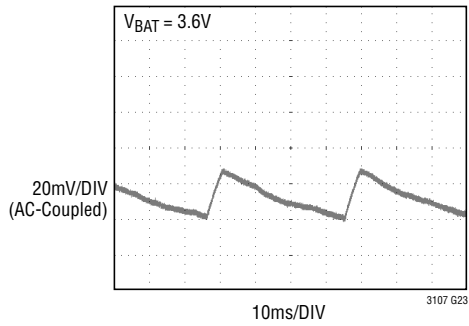

V_{OUT} Ripple, Not Harvesting

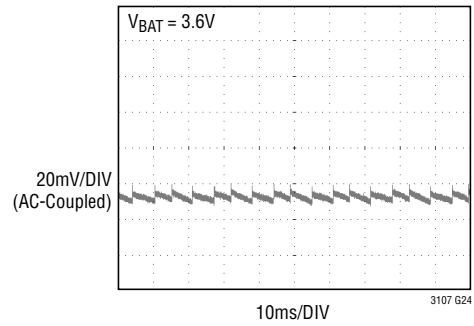

PIN FUNCTIONS

VAUX (Pin 1): Output of the Internal Rectifier Circuit and V_{CC} for the IC. Bypass VAUX with 10 μ F of capacitance. An active shunt regulator clamps VAUX to 4.3V (typical).

VSTORE (Pin 2): Output for the Optional Energy Storage Capacitor. A large capacitor may be connected from this pin to GND to store excess harvested energy, further extending battery life in the event of an increase in load. It will be charged up to the maximum VAUX clamp voltage. If not used, this pin should be left open or tied to VAUX.

V_{OUT} (Pin 3): Main Output of the Converter. When harvested energy is available, the voltage at this pin is regulated to 30mV below the voltage on the V_{BAT} pin. If no (or insufficient) harvested energy is available to power the load, V_{OUT} will be regulated to a voltage about 230mV below the voltage at V_{BAT} . A large decoupling capacitor is usually required from V_{OUT} to GND, to allow the output to ride-through short duration load transients without drawing current from the battery. A minimum capacitance value of 47 μ F is recommended for all applications. See the Applications Information section for details on sizing the capacitor.

V_{BAT} (Pin 4): Primary Battery Input. This pin must be connected to a primary battery. This input will be used during start-up to bring V_{OUT} into regulation (as well as VAUX and VLDO). After start-up, this input is used only as a reference voltage for V_{OUT} , unless there is insufficient harvested power available, in which case it will power the

IC and the loads on V_{OUT} and VLDO. A ceramic decoupling capacitor with a minimum value of 10 μ F is recommended from V_{BAT} to GND.

VLDO (Pin 5): Output of the 2.2V LDO, which is powered from the higher of V_{OUT} or VAUX. Connect a 2.2 μ F or larger ceramic capacitor from VLDO to GND. If not used, this pin should be tied to VAUX.

GND (Pin 6 and Exposed Pad Pin 11): Ground Pin for the IC. The exposed pad must be soldered to the PCB ground plane. It serves as a ground connection, and as a means of conducting heat away from the die.

BAT_OFF (Pin 7): Battery Off Output. This pin is an indicator of when the battery is in use. A logic low indicates that the battery is being used to assist in regulating V_{OUT} . The pin will go high when V_{OUT} is in regulation and the battery is not being used. It is not designed to source any current. It has an internal 1M pull-up resistor to V_{OUT} .

C1 (Pin 8): Input to the Charge Pump and Rectifier Circuit. Connect a capacitor from this pin to the secondary winding of the step-up transformer.

C2 (Pin 9): Input to the N-Channel Gate Drive Circuit. Connect a capacitor from this pin to the secondary winding of the step-up transformer.

SW (Pin 10): Drain of the Internal N-Channel Switch. Connect this pin to the primary winding of the transformer.

BLOCK DIAGRAM

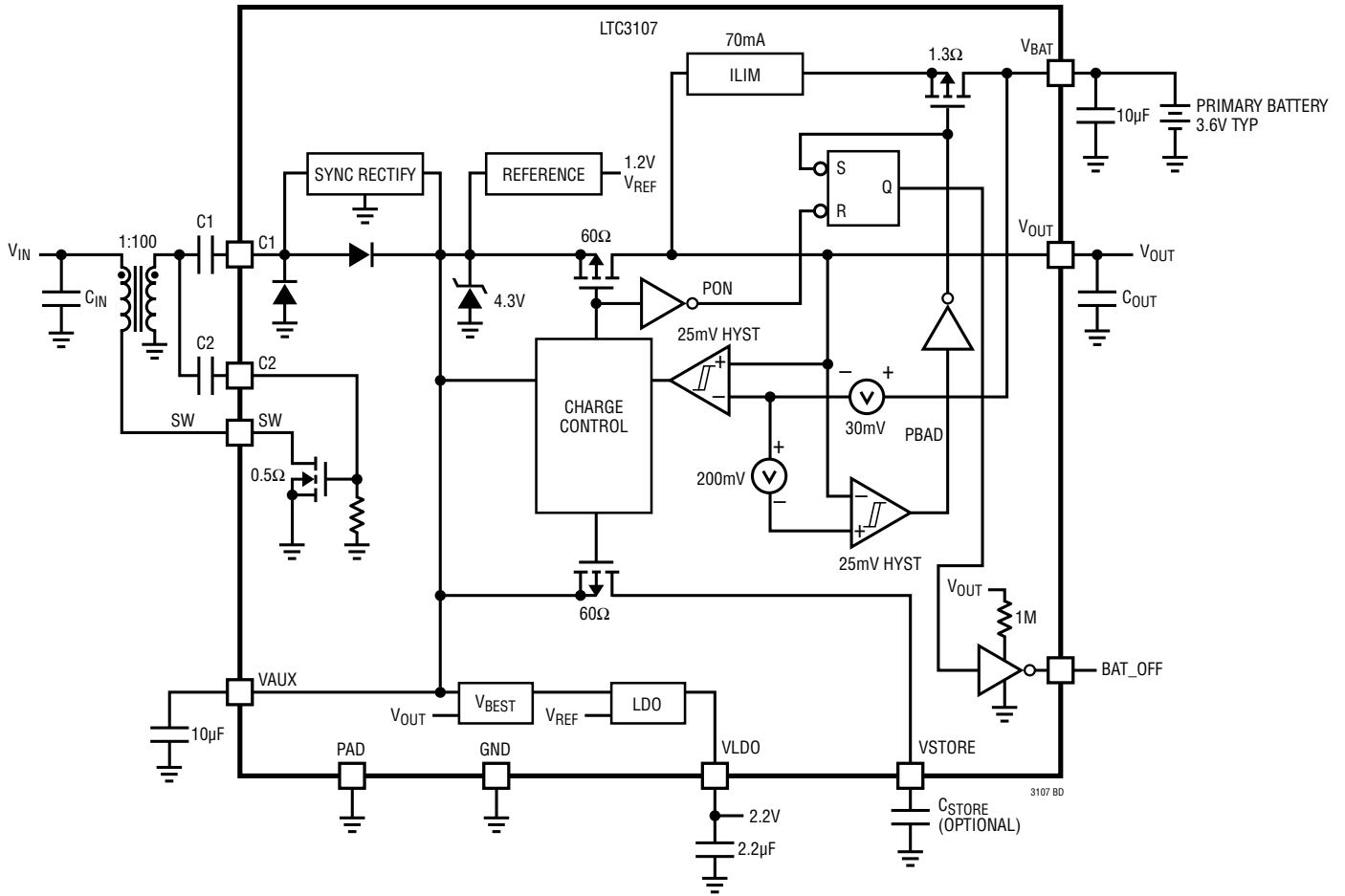

OPERATION

The LTC3107 is an ultra-low input voltage step-up DC/DC converter and power manager for extending the battery life of low power wireless sensors and other low power applications that utilize a primary battery. The LTC3107 intelligently manages harvested energy from sources such as TEGs (Thermo-Electric Generators) to service the output while minimizing battery drain, thereby maximizing battery life.

To simplify the adoption of energy harvesting by applications presently powered by a primary battery, the LTC3107 is designed to use the voltage on the V_{BAT} pin not only as an energy source to power the outputs in the absence of harvested input energy, but also as a voltage reference to regulate V_{OUT} . In this way, the LTC3107 automatically adapts V_{OUT} to track whatever battery voltage the application is already designed for, in the range of 2V to 4.0V.

The LTC3107 is suitable for extending the battery life in applications where the average power draw is very low, but where periodic pulses of higher load current may be required. This is typical of wireless sensor applications, where the quiescent power draw is extremely low a high percentage of the time, except during transmit bursts when circuitry is powered up to make measurements and transmit data.

The LTC3107 can also be used to trickle charge a standard capacitor or supercapacitor to store excess harvested energy when it is available. This further extends the life of the primary battery, by allowing the converter to ride-through periods of heavier load, or times when no harvested energy is coming in by drawing from this reservoir before switching over to the battery.

V_{BAT} Input

The V_{BAT} input should be connected to a primary battery with a voltage between 2V and 4.0V. Typical examples are 2 Alkaline cells, a single 3V Lithium coin cell, or a 3.6V Li-SOCl₂ battery. These are representative batteries that would normally power the application without the benefit of energy harvesting.

The LTC3107 is designed to use the battery to start-up the IC and power V_{OUT} and VLDO with or without any harvested energy available. If there is no harvester input, or insufficient harvester input to power the load, then V_{OUT} will be provided by the battery through a current-limited switch internal to the LTC3107, and will be hysteretically regulated to a voltage 230mV below the battery voltage. The VLDO output will be fixed at 2.2V unless V_{BAT} is below 2.2V, in which case it will track V_{BAT} . When no harvested energy is available, the LTC3107 average quiescent current draw from the battery is typically 6 μ A.

If there is sufficient harvested energy available, then V_{OUT} will be regulated to a voltage approximately 30mV below the V_{BAT} voltage, and the battery will not be used to power V_{OUT} . In this case, the battery current draw will drop to just 80nA typical.

Oscillator

The LTC3107 utilizes a MOSFET switch to form a resonant step-up oscillator using an external step-up transformer and a small coupling capacitor. This allows it to boost input voltages as low as 20mV up to values high enough to provide multiple regulated output voltages for powering other circuits. The frequency of oscillation is determined by the inductance of the transformer secondary winding, and is typically in the range of 10kHz-100kHz. For input voltages as low as 20mV, a primary-secondary turns ratio of about 1:100 is recommended. For higher input voltages, this ratio can be lower. See the Applications section for more information on selecting the transformer.

Charge Pump and Rectifier

The AC voltage produced on the secondary winding of the transformer is boosted and rectified using an external charge pump capacitor (from the secondary winding to pin C1) and the rectifiers internal to the LTC3107. The rectifier circuit feeds current into the VAUX pin, providing charge to the external VAUX capacitor. Once VAUX exceeds 2V, synchronous rectifiers in parallel with each of the diodes take over the job of rectifying the input voltage, improving efficiency.

OPERATION

VAUX

The active circuits within the LTC3107 are powered from VAUX, which should be bypassed with a capacitor of 10 μ F minimum.

The quiescent current draw on VAUX is typically just 6 μ A. If harvested energy is available, this current will come from the harvesting source. If there is no harvesting energy available, the VAUX supply current will come from V_{BAT}.

A shunt regulator limits the maximum voltage on VAUX to 4.3V typical. It shunts to ground any excess harvested current into VAUX when there is no load on the converter or the input source is generating more power than is required by the load. If the optional storage capacitor is connected to VSTORE, then the excess current will be used to charge the storage capacitor, and current will not be shunted to ground until the storage capacitor is charged up to the 4.3V clamp level.

Voltage Reference

The LTC3107 includes a precision, micropower reference, for accurate regulated output voltages. This reference becomes active as soon as VAUX exceeds 1.9V.

Low Dropout Linear Regulator (LDO)

The LTC3107 includes a low current LDO to provide a regulated 2.2V output for powering low power processors. The LDO is powered by the higher of VAUX or V_{OUT}, and requires a minimum of 2.2 μ F ceramic decoupling capacitor. Larger capacitor values can be used without limitation.

If the LDO is not being used, the VLDO pin should be tied to VAUX.

V_{OUT}

The LTC3107 is designed to fit seamlessly into existing applications that run from a primary battery, while adding the benefit of energy harvesting to increase the life of the battery. The main output voltage on V_{OUT} is designed to track the battery voltage on V_{BAT}. If no harvested energy is available, or the energy is insufficient to maintain V_{OUT}, then V_{OUT} will be hysteretically regulated 230mV below V_{BAT} by periodically connecting it to V_{BAT}.

When enough harvested energy is available to power the load, V_{OUT} will be hysteretically regulated to a voltage typically 30mV below V_{BAT}, and the battery will not be used. In this condition, the current drain on the battery is only 80nA typical.

In a typical application, a bulk decoupling capacitor (usually a few hundred microfarads) is connected to V_{OUT} to allow it to ride-through small, periodic load transients typical of a wireless sensor application. If the V_{OUT} capacitor is sized appropriately (see the Applications Information section for more detail), and the average harvested input power exceeds the average load power, then battery energy will never be used.

BAT_OFF

The BAT_OFF output is a digital output with an internal pull-up to V_{OUT}. BAT_OFF is an indicator of when the battery is being used to help maintain V_{OUT}. If BAT_OFF is high, it indicates that V_{OUT} (and VLDO) are being powered entirely by the harvested input power (including the VSTORE capacitor), and the battery is not being used. In this case, the battery current draw is only 80nA typical. When BAT_OFF goes low, it indicates that the battery is being used to help maintain V_{OUT} and VLDO in regulation. This indicates that either there is no harvested energy available, or it is insufficient to power the load entirely. If the C_{OUT} capacitor is not sized properly, the BAT_OFF indicator may go low during a pulsed load event, to indicate that current is being drawn from the battery. See the Applications Information section of this data sheet for guidance on sizing the C_{OUT} capacitor.

VSTORE

The VSTORE output can be used to charge an optional storage capacitor, after V_{OUT} has reached regulation. The VSTORE capacitor value can range from hundreds of micro-farads up to Farads. Once V_{OUT} has reached regulation, the VSTORE output will be allowed to charge up to the maximum VAUX voltage if excess harvested energy is available. The storage capacitor on VSTORE can be used to power the system in the event that the input source is lost, or is unable to provide the current demanded by the loads on V_{OUT} and VLDO, or simply to supplement the

OPERATION

V_{OUT} capacitor to reduce V_{OUT} ripple during load steps. The LTC3107 will automatically use energy from the VSTORE capacitor to maintain V_{OUT} in regulation before drawing any current from the battery. Note that it may take a long time to charge a large VSTORE capacitor, depending on the harvested energy available and the loading on V_{OUT} and VLDO.

If a storage capacitor is not being used, the VSTORE pin can be left open or tied to VAUX.

Short Circuit Protection

All outputs of the LTC3107 are current limited to protect against short circuits.

Output Voltage Sequencing

A diagram showing the typical output voltage profiles during start-up with an energy harvesting source is shown in Figure 1.

Operation with Battery Removed

Although the LTC3107 is designed to have a primary battery connected to V_{BAT} , there may be times when the battery is removed for a short duration (such as for maintenance).

If there is sufficient harvested energy (or stored energy) available to maintain V_{OUT} and VLDO, then the current draw on V_{BAT} will be only 80nA, plus any leakage from the V_{BAT} decoupling capacitor, which should be very small (typically less than 1 μ A). In this case, if the battery is removed, the capacitor on V_{BAT} will hold-up the V_{BAT} voltage, allowing V_{OUT} to maintain regulation. As the V_{BAT} voltage slowly decays due to leakage, V_{OUT} will follow it. For example, if the V_{BAT} decoupling capacitor is 20 μ F nominal, and the total leakage on V_{BAT} is 0.1 μ A, then V_{BAT} and V_{OUT} will decay at a rate of 5mV per second.

If there is no harvested or stored energy available to power V_{OUT} and VLDO, then these voltages will drop when the battery is removed. In this case, their rate of decay will be determined solely by the amount of capacitance on V_{OUT} (since it is generally much larger than the VLDO capacitor) and the combined load current on V_{OUT} and VLDO.

OPERATION

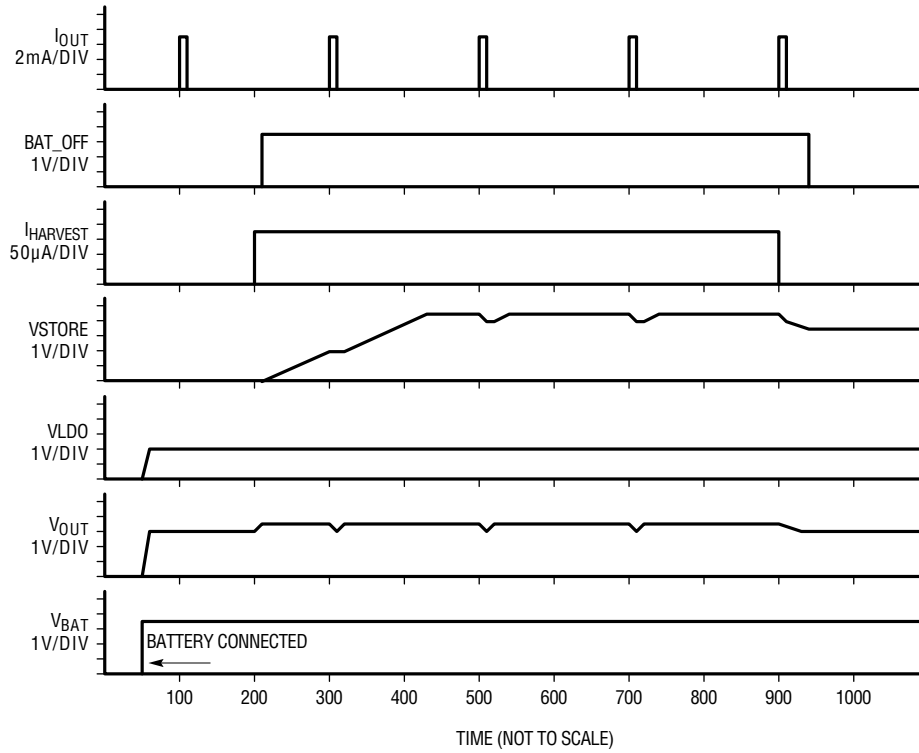

3107 F01

Figure 1. Typical Start-Up Voltage Waveforms

OPERATION

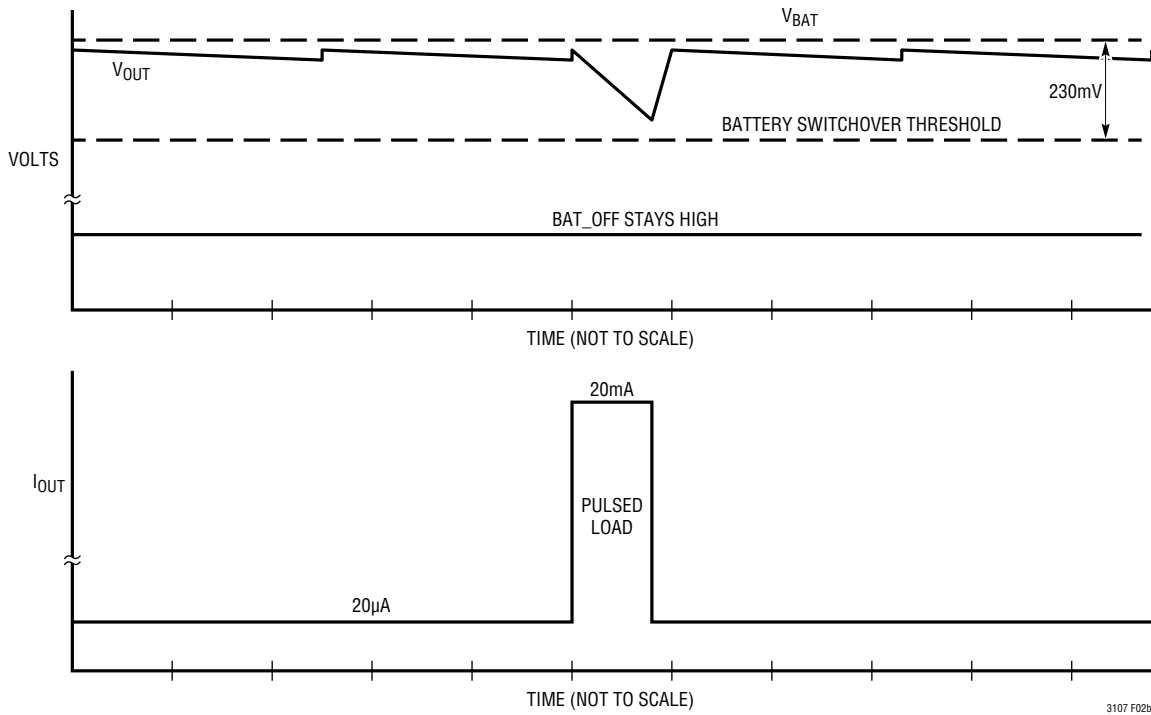

Figure 2a. V_{OUT} Waveform During a Pulsed Load, with Correctly Sized C_{OUT} and $I_{HARVEST} > I_{LOAD}$ (Average)

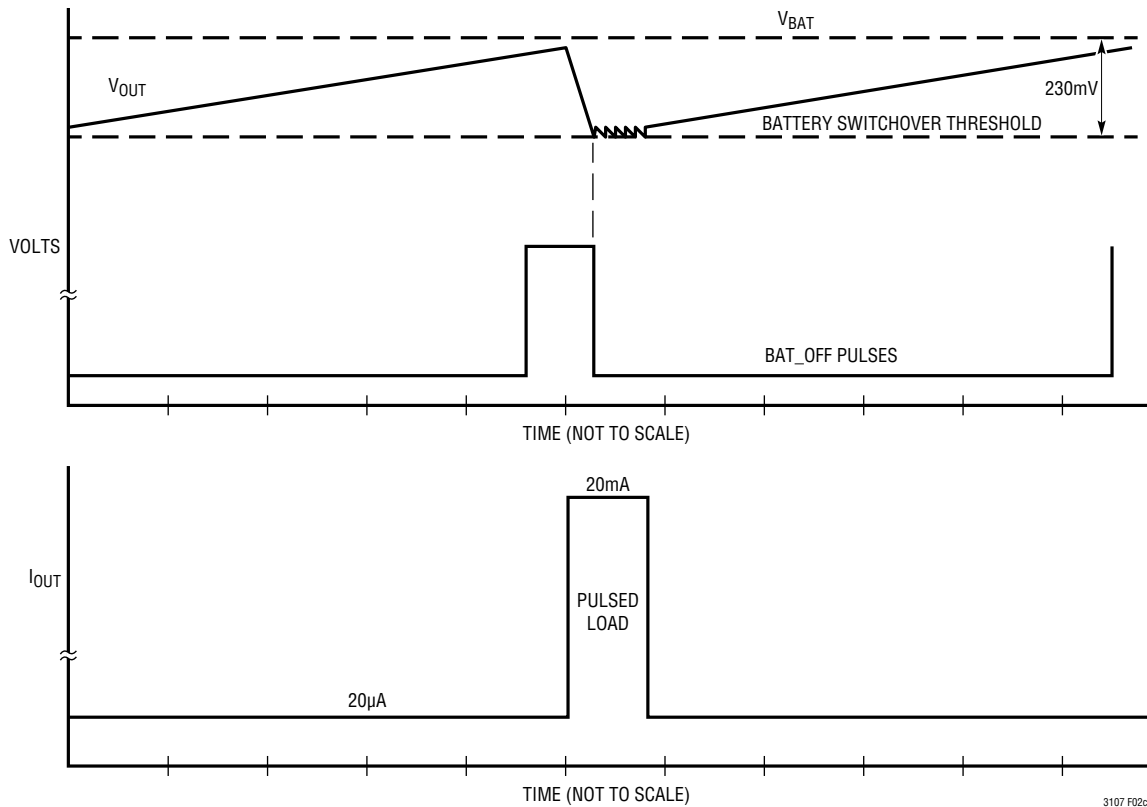
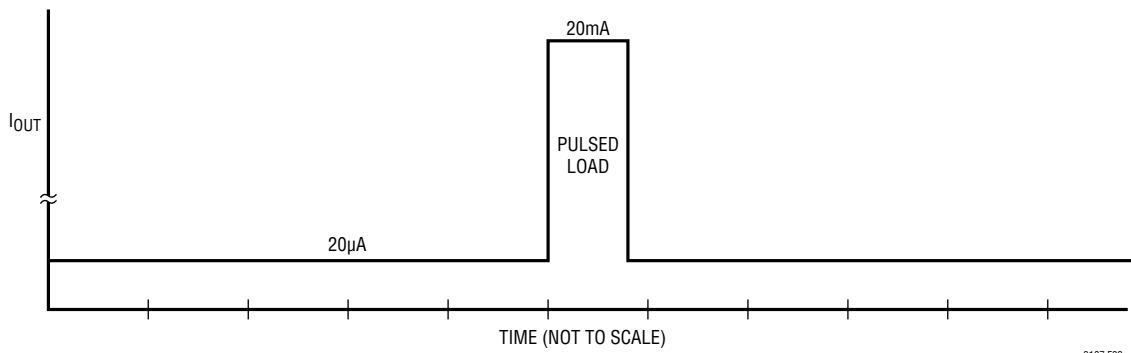
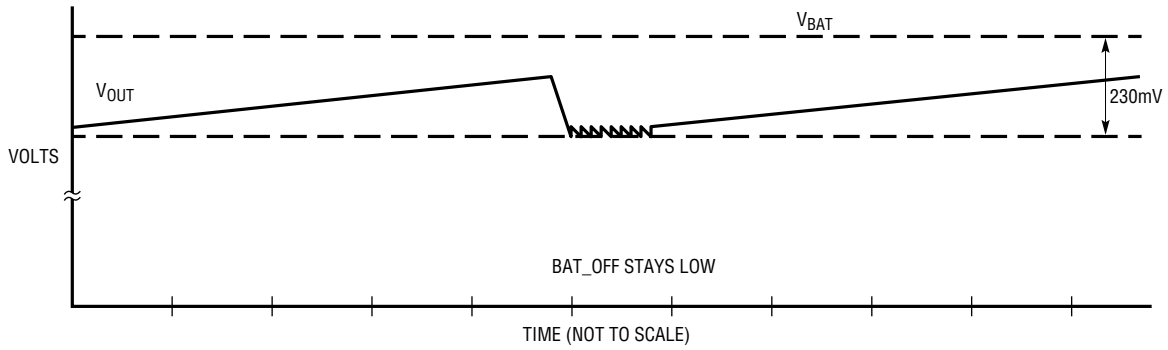

Figure 2b. V_{OUT} Waveform During a Pulsed Load, with Insufficient C_{OUT} Value, $I_{HARVEST} > I_{LOAD}$ (Average)

OPERATION



3107 F02c

Figure 2c. V_{OUT} Waveform During a Pulsed Load When $I_{HARVEST} < I_{LOAD}$ (Average)

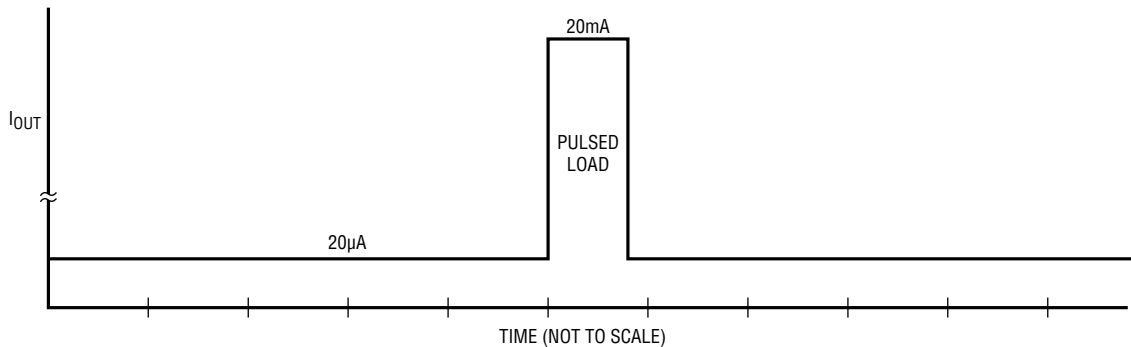
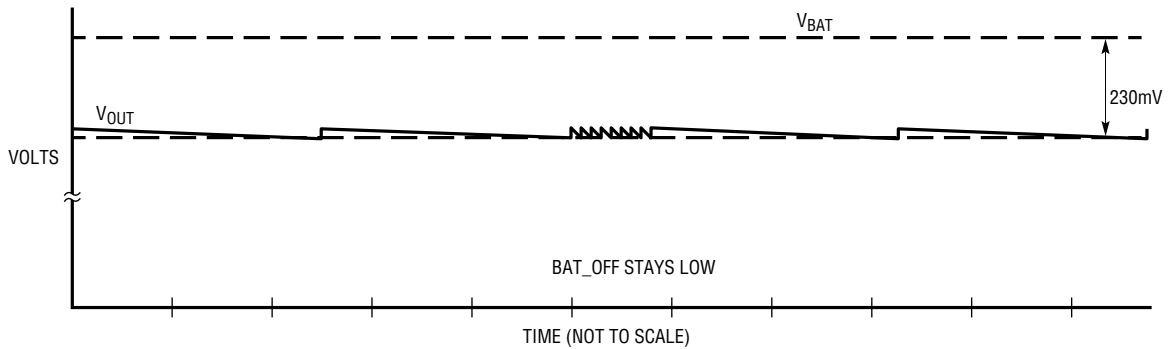

3107 F02d

Figure 2d. V_{OUT} Waveform During a Pulsed Load When Not Harvesting

APPLICATIONS INFORMATION

Introduction

The LTC3107 is designed to gather energy from very low input voltage sources and use it to extend the life of a primary battery in applications such as wireless sensors. The LTC3107 is designed to accumulate and manage energy over long periods of time to enable short power bursts for acquiring and transmitting data. These bursts must occur at a low enough duty cycle such that the total output energy during the burst does not exceed the average source power integrated over the accumulation time between bursts. In these instances, the battery will not be used at all, so the battery life may be extended up to the shelf life of the battery.

Harvesting Input Voltage Sources

The LTC3107 can operate from a number of low input voltage sources, such as thermoelectric generators, thermopiles and coil and magnet transducers. The minimum input voltage required for a given application will depend on the transformer turns ratio, the load power required, and the internal DC resistance (ESR) of the voltage source. Lower ESR sources (typically less than 10Ω) will allow the use of lower input voltages, and higher output power capability.

For a given transformer turns ratio, there is a maximum recommended input voltage to avoid excessively high secondary voltages and power dissipation in the shunt regulator. It is recommended that the maximum input voltage times the turns ratio be less than 50.

Note that a low ESR bulk decoupling capacitor may be required across the input source to prevent large voltage droop and ripple caused by the source's ESR and the peak primary switching current (which can reach hundreds of milliamps). The time constant of the filter capacitor and the ESR of the voltage source should be much longer than the period of the resonant switching frequency.

Peltier Module (Thermoelectric Generator)

A Peltier module (also known as a thermoelectric cooler) is made up of a number of series-connected P-N junctions, sandwiched between two parallel ceramic plates. Although Peltier modules are often used as coolers by applying a DC voltage to their inputs, they will also generate a DC output voltage, using the Seebeck effect, when the two plates are held at different temperatures. The polarity of the output voltage will depend on the polarity of the temperature differential between the plates. The magnitude of the output voltage is proportional to the magnitude of the temperature differential between the plates. When used in this manner, a Peltier module is referred to as a thermoelectric generator (TEG).

The low voltage capability of the LTC3107 design allows it to operate from a TEG with temperature differentials as low as 1°C to 2°C , making it ideal for harvesting energy in applications where a temperature difference exists between two surfaces or between a surface and the ambient temperature. The internal resistance (ACR) of most TEGs is in the range of 1Ω to 10Ω , allowing for reasonable power transfer. The curves in Figure 3 show the open-circuit output voltage and maximum power transfer for a typical TEG with an ACR of 2Ω over a 20°C range of temperature differential. It can be seen that an output power of a few hundred microwatts is easily achievable with a small temperature differential. This is often more than enough to satisfy the average power demand of a low power wireless sensor.

Note that the thermal resistance of most TEGs is typically quite low (2°K/W to 20°K/W). Therefore, it may be difficult to sustain a large temperature differential across the TEG. The temperature differential will depend on the amount of heat transfer available. In most applications, this will be determined by the size of the heat sink used on the TEG, and the amount of air flow. For optimal performance, the thermal resistance of the heat sink should be at least as low as the thermal resistance of the TEG being used.

APPLICATIONS INFORMATION

Also note that most Peltier cells are limited to a maximum absolute temperature of around 125°C. For applications with a heat source above this temperature, a thermopile generator should be considered, as they are designed for much higher operating temperatures.

TEG Load Matching

The LTC3107 was designed to present a minimum input resistance (load) in the range of 2Ω to 10Ω, depending primarily on input voltage and transformer turns ratio (as shown in the Typical Performance Curves). For a given turns ratio, as the input voltage drops, the input resistance increases. This feature allows the LTC3107 to optimize power transfer from sources with a few Ohms of source resistance, such as a typical TEG. Note that a lower source resistance will always provide more output current capability (all other things being equal) by providing a higher input voltage under load to the converter.

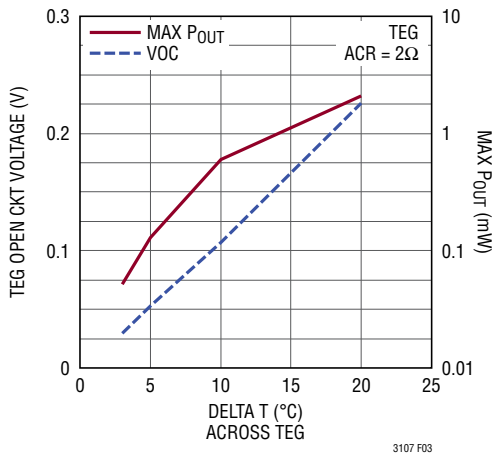

Figure 3. Typical Performance of a Peltier Module Acting as a Power Generator

Peltier Module Suppliers

Peltier modules are available in a wide range of sizes and power capabilities, from less than 10mm square to over 50mm square. They are typically 2mm to 5mm thick. A list of manufacturers that make Peltier modules appropriate for use with the LTC3107 is given in Table 1. Distributors that sell Peltier modules are shown in Table 2.

Table 1. Peltier Module Manufacturers

MANUFACTURER	Web Address
Marlow Industries	www.marlow.com
Nextreme	www.nextreme.com
Tellurex	www.tellurex.com
Ferro Tec	www.ferrotec.com
Z-Max	www.z-max.jp/peltier_en/peltier
CUI	www.cui.com
Laird Technologies	www.lairdtech.com

Table 2. Peltier Module Distributors

MANUFACTURER	Web Address
Digi-Key	www.digikey.com
Newark	www.newark.com
Farnell	www.farnell.com uk.farnell.com de.farnell.com

Thermopile Generator

Thermopile generators (also called powerpile generators) are made up of a number of series connected thermocouples, enclosed in a metal tube. They are commonly used in gas burner applications to generate a DC output of hundreds of millivolts when exposed to the high temperature of a flame. Typical examples are the Honeywell CQ200 and Q313. These devices have an internal series resistance of less than 3Ω, and can generate as much as 750mV open circuit at their highest rated temperature. For applications where the temperature rise is too high for a traditional Peltier thermoelectric device, a thermopile can be used as an energy source to power the LTC3107. Because of the higher output voltages possible with a thermopile generator, a much lower transformer turns ratio is recommended (typically 1:10 or 1:20, depending on the application).

COMPONENT SELECTION

Step-Up Transformer

The step-up transformer turns ratio will determine how low the input voltage can be for the converter to start. Using a 1:100 ratio can yield start-up voltages as low as 20mV. Other factors that affect performance are the DC resistance of the transformer windings and the inductance

APPLICATIONS INFORMATION

of the windings. Higher DC resistance will result in lower efficiency. The secondary winding inductance will determine the resonant frequency of the oscillator, according to the formula:

$$\text{FREQ} = \frac{1}{2 \cdot \pi \cdot \sqrt{L \cdot C}} \text{ Hz}$$

Where L is the inductance of the transformer secondary winding and C is the load capacitance on the secondary winding. This is comprised of the input capacitance at pin C2, typically 30pF, in parallel with the transformer secondary winding's shunt capacitance. The recommended resonant frequency is in the range of 10kHz to 100kHz. Note that the loading also plays a role in the effective load capacitance, and will therefore have an effect on the frequency. See Table 3 for some recommended transformers.

Table 3. Recommended Transformers

VENDOR	PART NUMBER
Coilcraft www.coilcraft.com	LPR6235-752SML (1:100 Ratio)
	LPR6235-123QML (1:50 Ratio)
	LPR6235-253PML (1:20 Ratio)
Würth www.we-online	74488540070 (1:100 Ratio)
	74488540120 (1:50 Ratio)
	74488540250 (1:20 Ratio)

C1 Capacitor

The charge pump capacitor that is connected from the transformer's secondary winding to the C1 pin has an effect on converter input resistance and maximum output current capability. Generally a minimum value of 1nF is recommended when operating from very low input voltages using a transformer with a ratio of 1:100. Too large a capacitor value can compromise performance when operating at low input voltage or with high resistance sources. For higher input voltages and lower turns ratios, the value of the C1 capacitor can be increased for higher output current capability. Refer to the Typical Application schematic examples for the recommended value for a given turns ratio.

Squegging

Certain types of oscillators, including transformer coupled oscillators such as the resonant oscillator of the LTC3107, can exhibit a phenomenon called squegging. This term refers to a condition that can occur which blocks or stops the oscillation for a period of time much longer than the period of oscillation, resulting in bursts of oscillation. An example of this is the Blocking Oscillator, which is designed to squegg to produce bursts of oscillation. Squegging is also encountered in RF oscillators and regenerative receivers.

In the case of the LTC3107, squegging can occur when a charge builds up on the C2 gate coupling capacitor, such that the DC bias point shifts and oscillation is extinguished for a certain period of time, until the charge on the capacitor bleeds off, allowing oscillation to resume. It is difficult to predict when and if squegging will occur in a given application. While squegging is not harmful, it reduces the average output current capability of the LTC3107.

Squegging can easily be avoided by the addition of a bleeder resistor in parallel with the coupling capacitor on the C2 pin. Resistor values in the range of 100k to 1MΩ are sufficient to eliminate squegging without having any negative impact on performance. For the 330pF capacitor used for C2 in most applications, a 499k bleeder resistor is recommended. See the Typical Applications schematics for an example.

Using External Charge Pump Rectifiers

The synchronous charge pump rectifiers in the LTC3107 (connected to the C1 pin) are low current and optimized for operation from very low input voltage sources, using typical transformer step-up ratios between 1:100 and 1:50, and typical C1 charge pump capacitor values less than 10nF.

Operation from higher input voltage sources (typically 250mV or greater, under load), allows the use of lower transformer step-up ratios (such as 1:20 and 1:10) and larger C1 capacitor values to provide higher output current capability from the LTC3107. However, due to the resulting increase in rectifier currents and resonant oscillator frequency in these applications, the use of external charge pump rectifiers is recommended for optimal performance in these applications.

APPLICATIONS INFORMATION

In applications where the step-up ratio is 1:20 or less, and the C1 capacitor is 10nF or greater, the C1 pin should be grounded and two external rectifiers (such as 1N4148 or 1N914 diodes) should be used. These are available as dual diodes in a single package, such as the BAS31. (Avoid the use of Schottky rectifiers, as their lower forward voltage drop increases the minimum start-up voltage.) See the Typical Applications schematics for an example.

V_{OUT} Capacitor

For pulsed load applications where there is no energy available from the V_{STORE} capacitor, the V_{OUT} capacitor should be sized to provide the necessary current when the load is pulsed on. The capacitor value required will be dictated by the combined load current on V_{OUT} and VLDO (I_{LOAD}), the duration of the load pulse (t), and the amount of voltage droop on the capacitor (ΔV_{VOUT}). With the goal being to extend battery life as much as possible, the maximum capacitor droop should be less than the amount required to trip the BAT_OFF comparator (which will connect the battery to maintain V_{OUT}). Therefore, the minimum recommended V_{OUT} capacitor value in pulsed load applications is:

$$C_{OUT}(\mu F) = \frac{I_{LOAD}(mA) \cdot t(ms)}{\Delta V_{VOUT}(V)}$$

Where ΔV_{VOUT} is typically 200mV. Note that even with a properly sized output capacitor, there must be more average harvested power available than the average load power requirement on V_{OUT} to prevent using the battery. A minimum C_{OUT} capacitor value of 47μF is recommended for all applications, even if there is no pulsed load.

V_{STORE} Capacitor

The V_{STORE} capacitor, C_{STORE}, may be of very large value (thousands of microfarads or even Farads), to provide energy storage for times when the harvested input power may be lost or the load requirement is higher. Note that this capacitor can charge up to 4.48V max, so be sure that the holdup capacitor has a working voltage rating of at least 4.5V at the temperature that it will be used. The LTC3107 is designed to use energy from the V_{STORE} capacitor to maintain V_{OUT} before using the battery.

C_{STORE} can be sized using the following equation (assuming no harvested energy or battery usage):

$$C_{STORE}(mF) = \frac{I_{LOAD}(mA) \cdot t(s)}{(4.3 - V_{BAT} - 0.2)(V)}$$

Where I_{LOAD} is the average load on V_{OUT} and VLDO combined. This assumes that the storage cap has had a chance to charge up to its typical clamp voltage of 4.3V.

To minimize losses and capacitor charge time, all capacitors used for V_{OUT} and V_{STORE} should be chosen for low leakage, relative to the average load current in the application. See Table 4 for recommended storage capacitors. Note that leakage is generally worse at higher temperatures, so be sure to take into account the actual operating temperature the capacitor will see in the application.

Table 4. Recommended Storage Capacitors

MANUFACTURER	SERIES
AVX	BestCap Series TAJ, TPS Series Tantalum
Cap-xx	G Series (Dual Cell) H Series (Dual Cell)
Cooper Bussmann	KR Series KW Series PA, PB, PM, PH Series
Illinois Capacitor	DCN Series
Vishay	293D Series (Tantalum) 595D Series (Tantalum) 153 CRV (Aluminum, Low Leakage) 150 CRZ (Aluminum, Low Leakage) 196 DLC (Double Layer Aluminum)

PCB Layout Guidelines

Due to the rather low switching frequency of the resonant converter and the low power levels involved, PCB layout is not as critical as with many other DC/DC converters. There are however, a number of things to consider.

APPLICATIONS INFORMATION

Due to the very low input voltage the circuit may operate from, the connections to V_{IN} , the primary of the transformer and the SW and GND pins of the LTC3107 should be designed to minimize voltage drop from stray resistance, and able to carry currents as high as 500mA. Any small voltage drop in the primary winding conduction path will lower efficiency, as well as the minimum start-up voltage.

Also, due to the low charge currents available at the outputs of the LTC3107, any sources of leakage current on the output voltage pins must be minimized. An example board layout is shown in Figure 4.

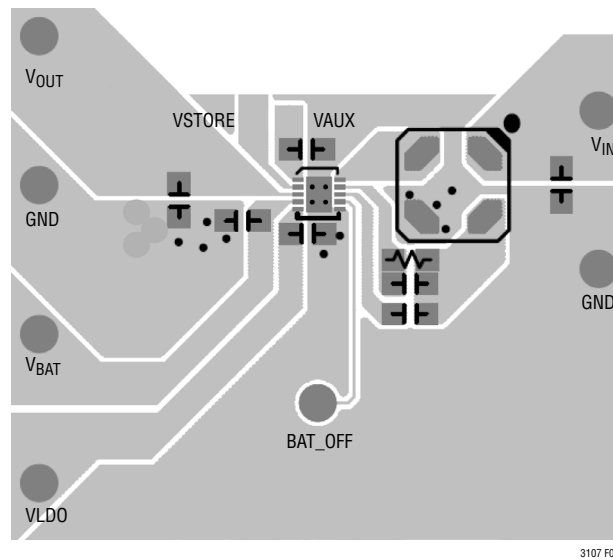
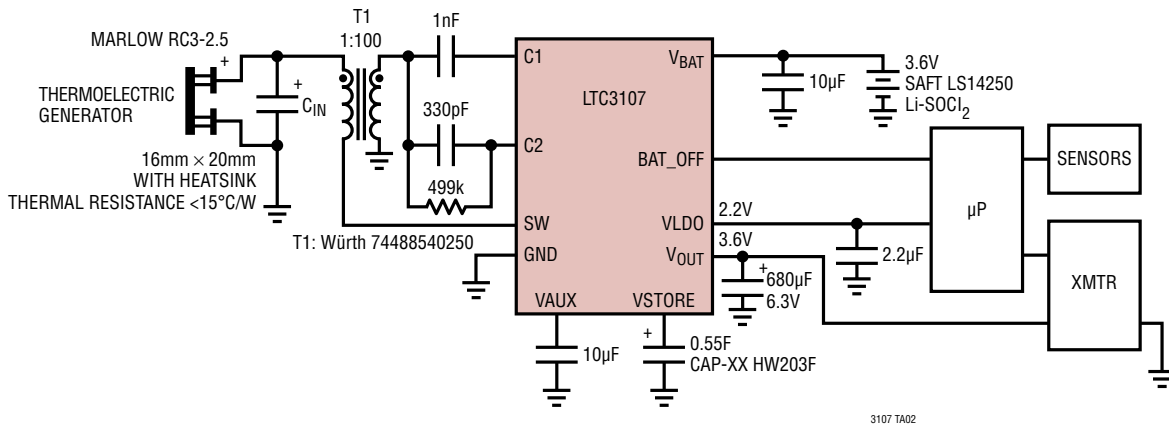

Figure 4. Example Component Placement for Two Layer PC Board

TYPICAL APPLICATIONS

Remote Sensor Application Using Thermal Energy Harvesting to Extend Primary Battery Life



0.55F VSTORE Capacitor Provides 6 Hours of Holdup at an Average Load of 200µw Before Using the Battery

Thermopile-Powered Battery Life Extender

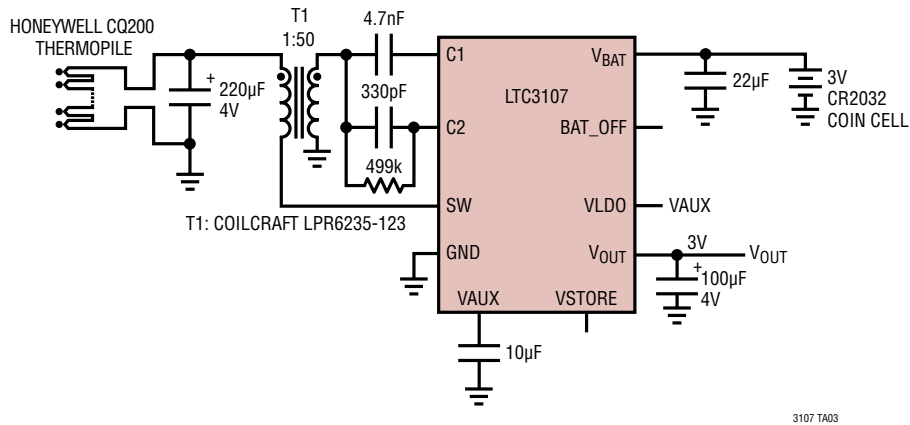

TYPICAL APPLICATIONS

3.6V Solar Powered Battery Life Extender Works from Indoor Lighting

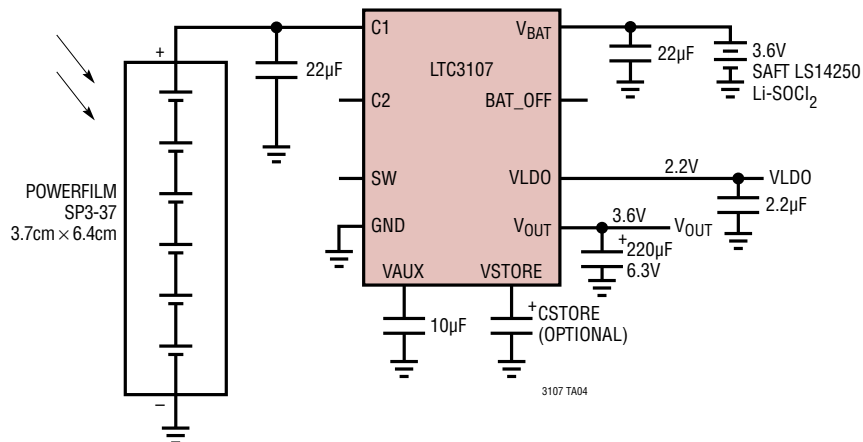

Dual Input Harvester Utilizes Thermal and Solar Energy

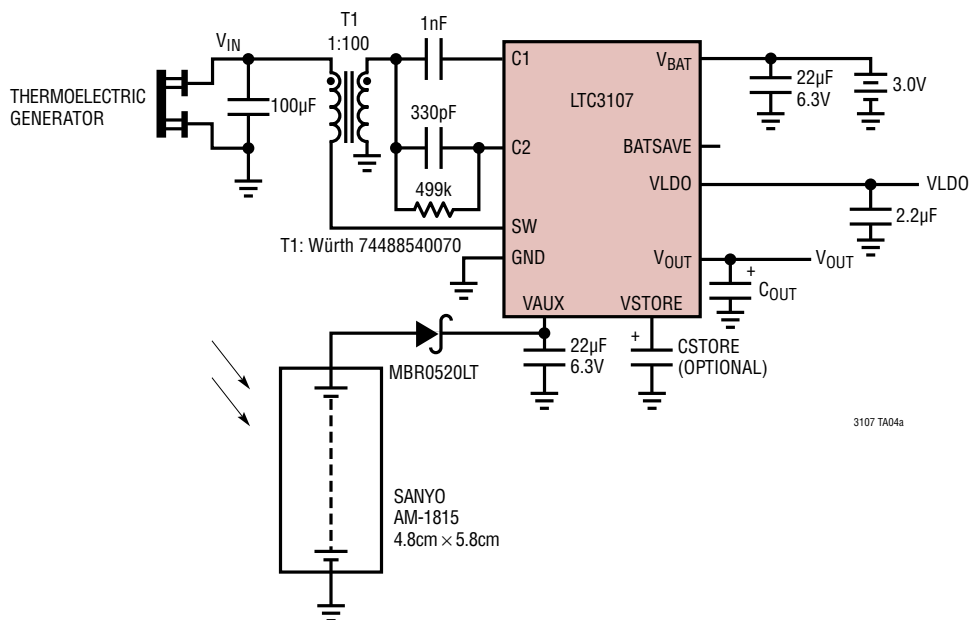

TYPICAL APPLICATIONS

Battery Life Extender Utilizing Scavenged 60Hz AC

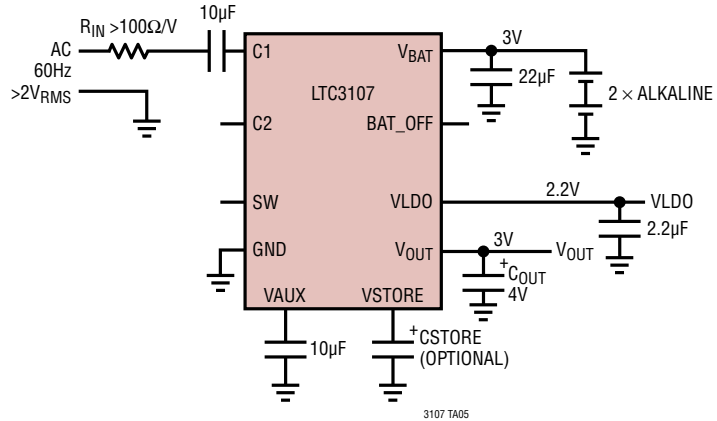

PACKAGE DESCRIPTION

Please refer to <http://www.linear.com/designtools/packaging/> for the most recent package drawings.

DD Package 10-Lead Plastic DFN (3mm × 3mm) (Reference LTC DWG # 05-08-1699 Rev C)

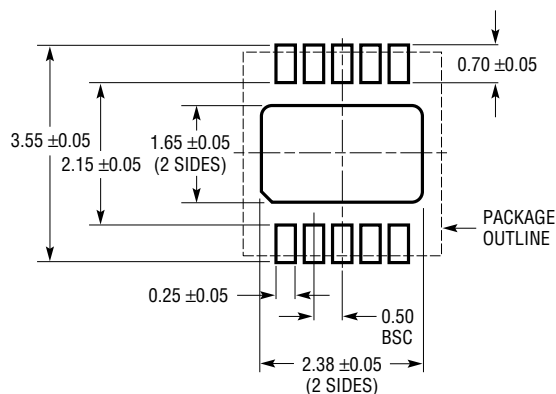

RECOMMENDED SOLDER PAD PITCH AND DIMENSIONS

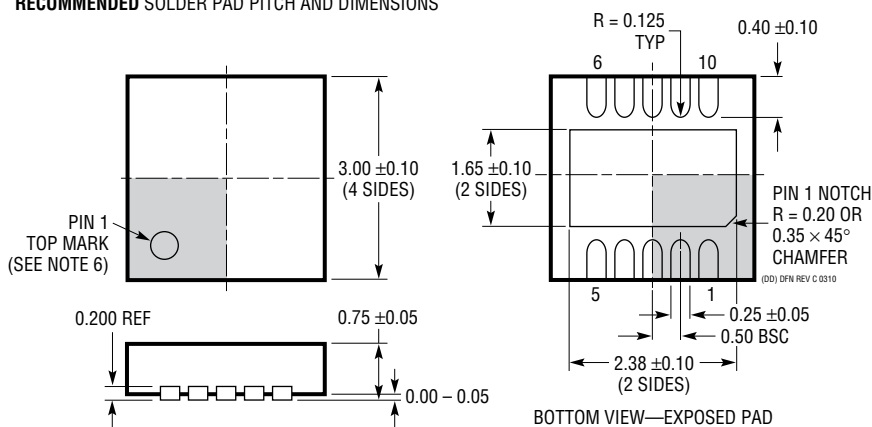

NOTE:

- DRAWING TO BE MADE A JEDEC PACKAGE OUTLINE MO-229 VARIATION OF (WEED-2). CHECK THE LTC WEBSITE DATA SHEET FOR CURRENT STATUS OF VARIATION ASSIGNMENT
- DRAWING NOT TO SCALE
- ALL DIMENSIONS ARE IN MILLIMETERS
- DIMENSIONS OF EXPOSED PAD ON BOTTOM OF PACKAGE DO NOT INCLUDE MOLD FLASH. MOLD FLASH, IF PRESENT, SHALL NOT EXCEED 0.15mm ON ANY SIDE
- EXPOSED PAD SHALL BE SOLDER PLATED
- SHADED AREA IS ONLY A REFERENCE FOR PIN 1 LOCATION ON THE TOP AND BOTTOM OF PACKAGE