

# **LX3302A and LX3301A Sensor Evaluation Kit**



## Introduction

The LX3302AQPW and LX3301AQPW ICs are a low cost, high-accuracy and superior magnetic noise immune position sensor IC. The sensor system consists of the inductive position sensor ICs, its printed circuit board sensor, and the target. A target Metal is attached to the moving mechanical housing, which provides position relative to the fixed position of sensor PCB.

The inductive PCBs are constructed using printed circuit board material

The sensor assembly is connected to the USB IPCE Programmer Interface through a 4-wires cable carrying +5V, GND, IO2 (DOUT) and IO3 (AOUT). The IPCE Programmer allows programming of LX3302AQPW and LX3301AQPW internal configuration EEPROM.

## 1. Features

The LX3302A and LX3301A evaluation position sensor kits include the following features:

- Inductive sensor measurement IC in TSSOP14 package
- Low cost, easy to manufacture inductive position sensor
- System calibration with on-chip calibration coefficient storage
- 4-wire system sensor interface
- Firmware and Configuration EEPROM programming GUI
- Output can be programmed Analog, PWM (Push Pull or Open Drain) and Threshold detect (TD)
  - The LX3302A also include SENT, PSI5 and SIN/COS output signal formats.

### 1.1. LX3302A and LX3301A Evaluation Kit Contents

The Evaluation Kit contains the following items:

- Inductive position sensor PCB with target assembly
- IPCE interface programmer
- 4pin cable
- The IPCE Software downloaded from Microchip Technology [Inductive Position Sensor Landing Page](#)



Figure one - LX3302A Evaluation Kit

## 2. System Operation

The evaluation kit has been factory calibrated and is ready to use. The default operation requires a +5VDC power source which can be supplied either by an external DC power supply or the ICPE programmer connected to PC via USB.

The Inductive Sensor kit constitutes a main sensor board and a movable target PCB. The main sensor board contains two oscillator coils (OSC1 and OSC2) and two pickup coils (CL1 and CL2). The IC energizes the two oscillator coils. The position of the target varies the reception of the two pickup coils relative to each other. The IC demodulates the two received signals and generates an output signal representative of the relative difference between the CL1 and CL2 signals as shown Fig 2.

The values of the two OSC1 and OSC2 capacitors vary depending on the characteristics of the OSC1 and OSC2 printed circuit board layout pattern. The combination L/C impedance of the printed circuit board layout must be matched to the LX3302AQPW's and LX3301AQPW oscillation requirement. Improper matching will prevent oscillator startup and result in reduced measurement range. Refer to the LX3302AQPW and LX3301AQPW Data Sheets for these design parameters.

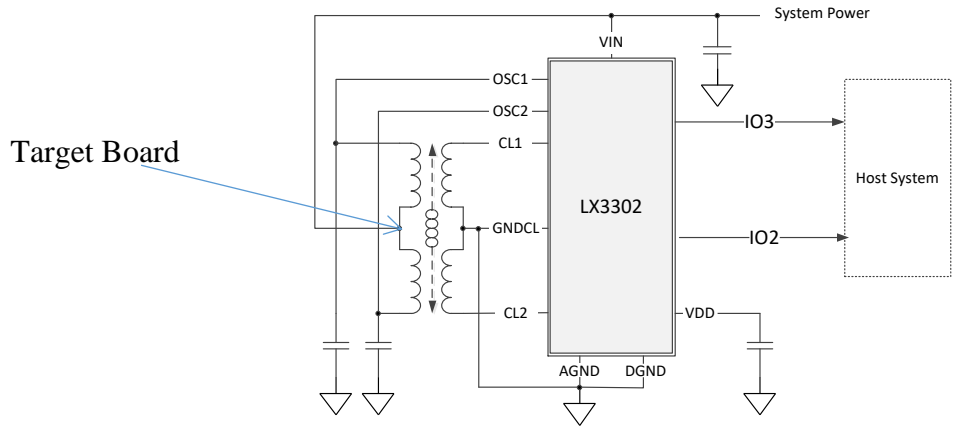

**Figure two - Inductive Sensor Operation Principle**

### 3. System Connections

The following figure shows the required external system equipment and their respective connections to the LX3302A evaluation board. The sensor assembly comes with 4pin connector (CN1) to connect to the IPCE Programmer. The pin out of this connector is shown below.

Pin#	Pin Name	Functional Description
1	GND	Ground
2	VIN	+5V Supply/Internal EEPROM Programming, Refer to datasheet for details
3	IO3 (AOUT)	LX3302AQPW IO3 output could be programmed to analog/PWM/SENT/PSI5/TD output. Refer to the LX3302AQPW datasheet. (LX3301AQPW DOUT output is the Analog/PWM/TD) Refer to the LX3301AQPW datasheet
4	IO2 (DOUT)	LX3302AQPW IO2 output could be programmed to PWM/SENT. (LX3301AQPW DOUT output is the PWM/TD)

**Figure three – CN1 Connector**

### 4. Inductive Sensor Board Typical Characteristics

The following plot displays an example of linearity achievable with the sensor with a SENT output. Other output formats will have the same accuracy.

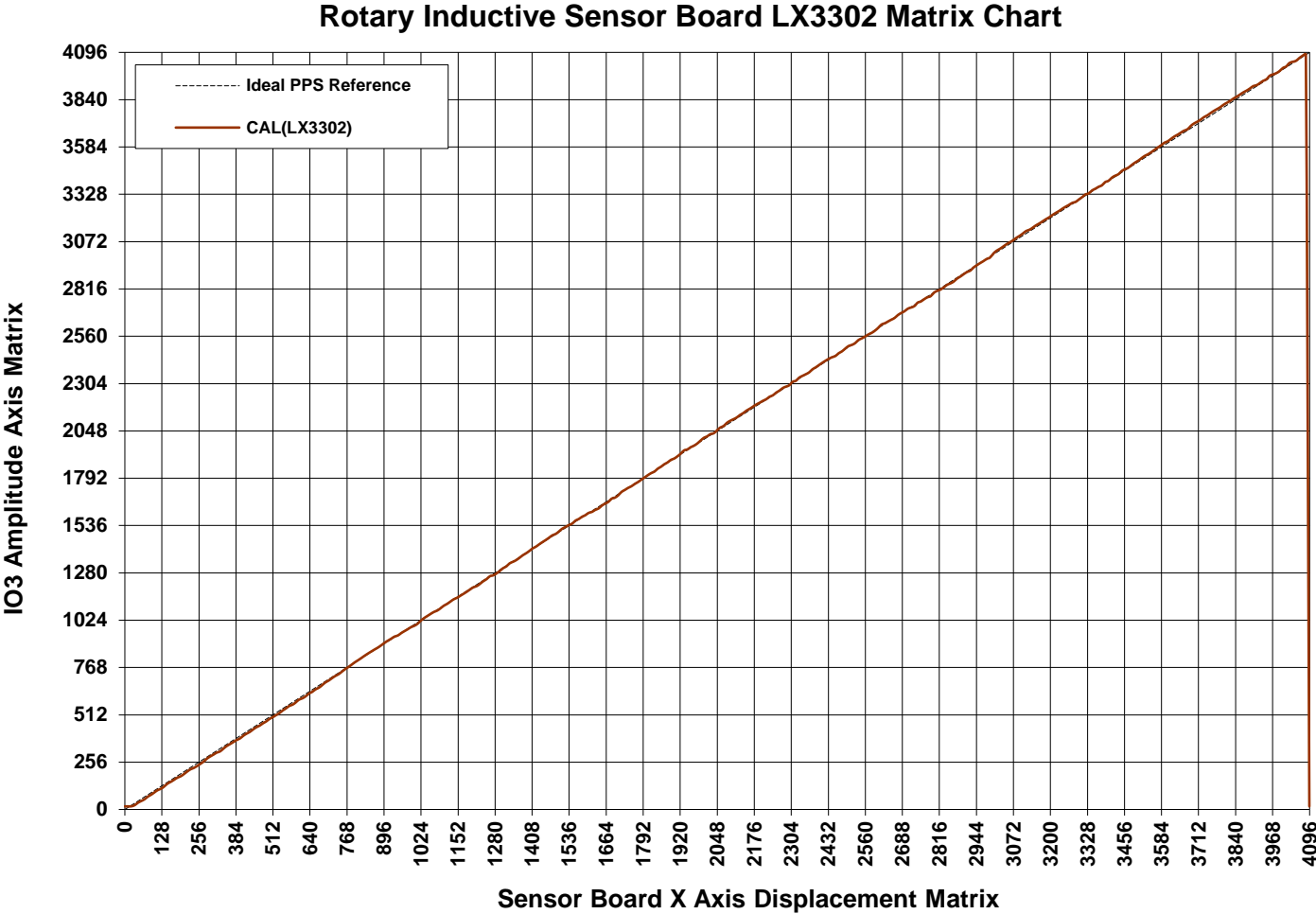

Figure 8 – An Example of typical Inductive Sensor Board Linearity (Calibrated)

## 5. Configuration EEPROM

The measurement IC contains an internal EEPROM for storing calibration and configuration parameters. The calibration parameters enable the production sensor assembly to be factory calibrated guaranteeing consistent unit-to-unit performance.

## 6. Kit EEPROM Programming IPCE

The sensor kit includes an Integrated Programming and Calibration Environment (IPCE) to facilitate system calibration and configuration. The Integrated Programming Environment contains an EEPROM Programming tool and data measuring system.

### 6.1 IPCE Installation

- 1) After downloading software from [web landing page](#), Unzip the IPCE contents.
- 2) Connect the cable of IPCE Programmer board to the Sensor PCB and plug the USB cable from the IPCE programmer to the PC.
- 3) If your operating system does not recognize the dongle, please install the dongle driver  
-IPCE > driver > lx33xx dongle driver > Microchip USB Driver
- 4) When you are connected, dongle status will report that the port is open.

#### 6.2.1 Calibration of the EVB

The sensor is factory calibrated. Please read the EEPROM contents and save it as original prior to re-calibrate the EVB. For detailed calibration procedure, refer to the calibration documents.