

## M12 Class 2 Features



- Uses a self-contained Class 2 modulated laser emitter with a visible red beam
- Beam is bore-sighted to within 2 milliradians and 0.25 mm of the housing centerline
- Useful for long-range sensing, or for sensing very small objects or profiles; excellent mechanical repeatability in position-sensing applications
- Features 12.7 mm diameter smooth aluminum barrel
- 10 V dc to 30 V dc supply voltage
- Compatible with a variety of photoelectric receivers
- Features collimated, apertured beam 2 mm in diameter, divergence of less than 1 milliradian
- Delivers excellent mechanical repeatability in position-sensing applications
- Available with unterminated, 2 m (6.5 ft) cable or 150 mm (6 in) quick-disconnect cable
- Modulated beam (33 kHz, 25% duty cycle)

### WARNING:



- **Do not use this device for personnel protection**
- Using this device for personnel protection could result in serious injury or death.
- This device does not include the self-checking redundant circuitry necessary to allow its use in personnel safety applications. A device failure or malfunction can cause either an energized (on) or de-energized (off) output condition.

### CAUTION:



- **Never stare directly into the sensor lens.**
- Laser light can damage your eyes.
- Avoid placing any mirror-like object in the beam. Never use a mirror as a retroreflective target.

### CAUTION:



- **Return defective units to the manufacturer.**
- Use of controls or adjustments or performance of procedures other than those specified herein may result in hazardous radiation exposure.
- Do not attempt to disassemble this sensor for repair. A defective unit must be returned to the manufacturer.

## M12 Class 2 Models

Model	Range	Connector	Supply Voltage
M126E2LD	Range varies, depending on which receiver is used (see <a href="#">"M12 Excess Gain"</a> on page 4)	2 m (6.5 ft) unterminated	10 V DC to 30 V DC
M126E2LDQ		150 mm (6 in) PVC-jacketed cable with a 3-pin M8 male quick-disconnect connector	

To order the 9 m (30 ft) PVC cable model, replace the suffix "Q" with "W/30" in the model number. For example, M126E2LD W/30. Models with a quick disconnect require a mating cordset.

## Installation

### Mount the M12 Laser Sensor

Mounting suggestions:

- To take advantage of the bore-sight beam placement offered by the M12 laser emitter, use a two-part clamp mount or a mounting block with a precision-drilled hole. Allow minimum clearance for the 12.7 mm (0.50 in) diameter housing, maximum diameter 12.83 mm (0.505 in).
- Clamp on both sides of the label. Do not clamp only on the labeled area. Use only plastic-tipped screws or set screws – not metal – to avoid compression of the housing.

Mounting bracket assembly model SMB46X3 is recommended for use with the M12. The assembly includes:

- A black-anodized aluminum block with holes drilled for mounting in any of 3 directions with plastic set screws
- An adjustable stainless-steel bracket with 3 spring-loaded screws (2 of the screws are used for precise alignment)

The mounting block, model SMB127, can be ordered separately.



Three Possible M12 Orientations



1. Insert the laser emitter into the SMB127 mounting block, through any of the three holes.
2. Make sure that the label area of the emitter is not aligned with a set screw.
3. Tighten the set screws, using the supplied 3/64-in Allen wrench, so that the emitter is held snugly in place.
4. Mount the block to the adjustable baseplate (or to your own bracket).
5. Mount the bracket base using your own M5 or #10 screws or bolts.
6. Check for alignment (see Alignment).
7. Tighten or loosen one or two of the precision alignment screws, using the supplied 2 mm Allen wrench, until the laser is accurately aligned.

M12 Laser Sensor Wiring

Quick disconnect wiring diagrams are functionally identical.

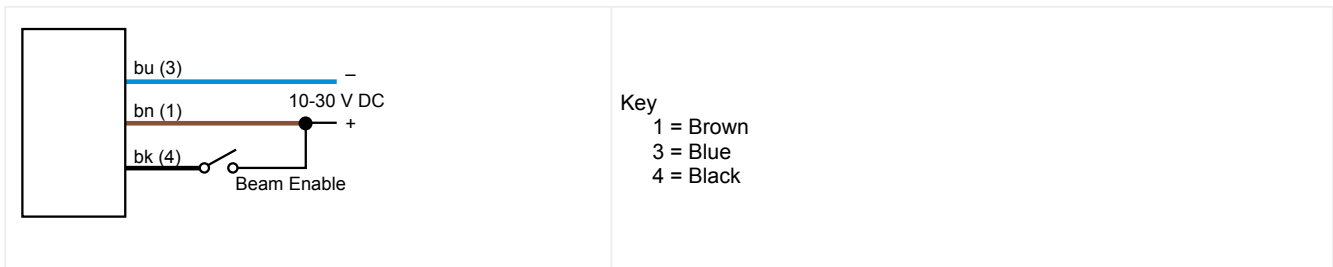

M12 Laser Emitter Alignment

M12 laser emitters have a beam divergence of only 0.03° (0.5 milliradians) at 25 °C (77 °F) ambient temperature. This translates, for example, to a beam diameter of only 9.5 mm (0.37 in) at a distance of 6.1 m (20 ft). Consequently, there is very little forgiveness for angular misalignment.

M12 laser emitter beam divergence at 25 °C (beam size vs. distance)

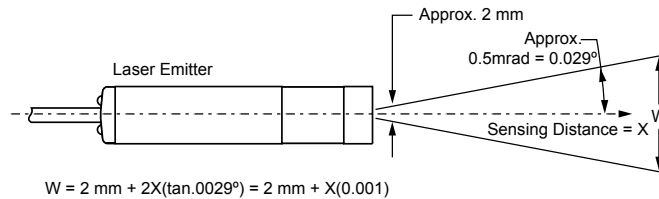

M12 laser emitter beam divergence at 25 °C (beam size vs. distance)

Opposed Distance (X)	Beam Width (W)
1.5 m (5 ft)	5.0 mm (0.20 in)
3 m (10 ft)	6.5 mm (0.26 in)
6 m (20 ft)	9.5 mm (0.37 in)
15 m (50 ft)	19 mm (0.75 in)
30 m (100 ft)	34 mm (1.34 in)

The beam size listed is also the effective beam size at the receiver. The effective beam is equal to the minimum opaque object profile required to block the light beam. The beam size at the emitter is 3.5 mm (0.14 in) diameter.

The effect of angular misalignment is dramatic. Laser emitters require their beam center to directly strike the receiver lens. "[Beam displacement per degree of misalignment](#)" on page 3 shows how far the laser beam will miss the center of the receiver lens for each degree of angular misalignment (in any plane). Note that even at only a 5 ft range, one degree of misalignment causes the laser beam to miss the lens of most receivers.

*Beam displacement per degree of misalignment*

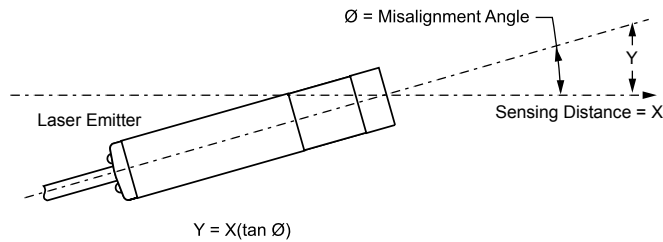

*Beam displacement per degree of misalignment*

Opposed Distance (X)	Beam Displacement (Y) for 1° of Misalignment
1.5 m (5 ft)	25 mm (1 in)
3 m (10 ft)	50 mm (2 in)
6 m (20 ft)	100 mm (4 in)
15 m (50 ft)	250 mm (10 in)
30 m (100 ft)	500 mm (20 in)

**Alignment Tip:** The visible red beam of the laser emitter is easily seen in subdued lighting.

**Alignment:**

1. At opposed distances of up to 3 m (10 ft), attach a sheet of white paper directly in front of the receiver lens.
2. Mark the location of the lens center on the paper. Use this mark as an aiming target.
3. Sight along the beam from directly behind the laser emitter.
4. Adjust the emitter mounting until the red image (the dot of red light) is centered exactly on the mark.
5. Remove the paper and check the response of the receiver.

For longer distances (up to 7.6 m or 25 ft), replace the white paper with a 102 mm × 102 mm (4 in × 4 in) square of high-grade retroreflective tape (Banner model BRT-THG-4X4-5 or equivalent). For greater distances, use a larger sheet of retroreflective material. Never use a mirror as an alignment target.

*At long distances, use retroreflective tape to locate the beam at the receiver location.*

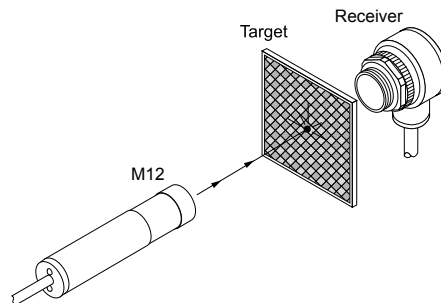

## M12 Specifications

**Supply Voltage and Current**

10 V DC to 30 V DC (10% max. ripple) at less than 30 mA

**Supply Protection Circuitry**

Protected against reverse polarity, transient voltages, and electrostatic discharge

**Delay at Power-Up**

Less than 30 milliseconds

**Sensing Beam**

Visible red Class 2 laser, 650 nm (temperature coefficient 0.2 nm/°C)

Pulse Width: 7 μs

Rep Rate: 30 μs

Peak Output Power: 2.8 milliwatts

**Beam Diameter at Aperture**

Approximately 3.5 mm (0.14 in) diameter

**Beam Placement**

Within 0.25 mm (0.01 in) and ±2 milliradians of mechanical centerline axis of housing

**Beam Divergence**

± 0.5 milliradians typical at 25° C; ±1.0 milliradians at operating temperature extremes

**Laser Classification**

Class 2 laser product; complies to 21 CFR 1040.10, EN 60825-1:2001 except for deviations pursuant to laser notice 50, dated 7-26-01

**Laser Control**

Beam enable: Apply + 10 V DC to 30 V DC to black wire

Beam inhibit: Apply 0 V or by opening circuit

Enable delay: Less than 30 milliseconds

Inhibit delay: Less than 1 milliseconds

**Indicators**

Indicators are visible through the rear cover

Green indicates power applied

Amber indicates laser enabled

**Connections**

2 m (6.5 ft) unterminated 3-wire PVC-jacketed high-flex cable, 9 m (30 ft) unterminated 3-wire PVC-jacketed high-flex cable, or 150 mm (6 in) PVC-jacketed cable with a 3-pin M8 male quick-disconnect connector

**Construction**

12.7 mm (0.50 in) diameter smooth aluminum barrel; black hard-coat anodized finish

MIL-A-8625 Type 2, Class 2

**Operating Temperature**

0 °C to +40 °C (+32 °F to +104 °F)

90% at +50 °C maximum relative humidity (non-condensing)

**Environmental Rating**

IP67

**Product Label**

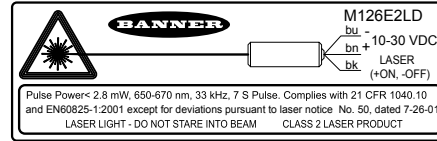

**Effective Beam at Receiver at 25° C**

Opposed Distance	Beam Width
1.5 m (5 ft)	5 mm (0.20 in)
3 m (10 ft)	6.5 mm (0.26 ft)
6 m (20 ft)	9.5 mm (0.37 ft)
15 m (50 ft)	19 mm (0.75 ft)
30 m (100 ft)	34 mm (1.34 in)

**Certifications**



Banner Engineering BV  
 Park Lane, Culliganlaan 2F bus 3  
 1831 Diegem, BELGIUM



Turck Banner LTD Blenheim House  
 Blenheim Court  
 Wickford, Essex SS11 8YT  
 GREAT BRITAIN

**M12 Laser Dimensions**

All measurements are listed in millimeters [inches], unless noted otherwise.

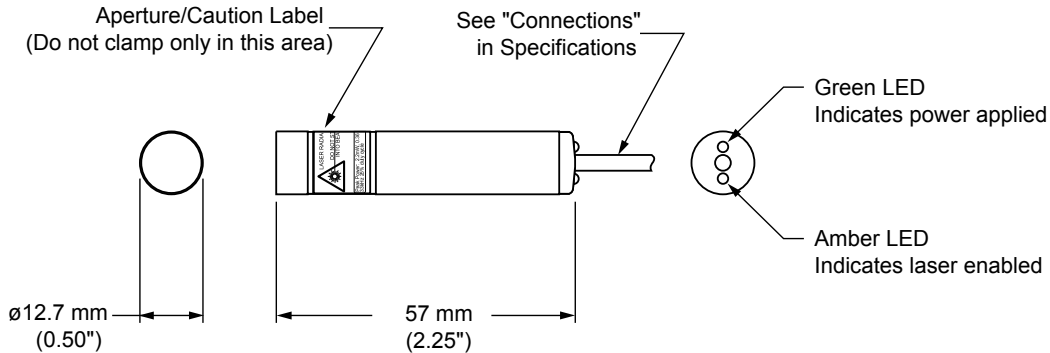

**M12 Excess Gain**

The excess gain of the M12 emitter depends on the particular receiver used. The following compares the excess gain for various recommended receivers at 15 m (50 ft).

For information on the compatibility of the M12 emitter with other Banner photoelectric receivers, contact Banner Engineering.

**MULTI-BEAM Models**

- SBRX1: 19,000
- SBR1: 19,000
- SBRXD1: 19,000
- SBRD1: 19,000

**MAXI-BEAM Models**

- RSBR: 14,000
- RSBRSR: 1,500

**VALU-BEAM Models**

- SMW95R: 34,000
- SMI91RQD: 18,000

**EZ-BEAM Models**

- T18SN6R: 7,500
- T30SN6R: 7,500
- S12SN6R: 7,500

**MINI-BEAM Models**

- SM31R: 2,500
- SM31RL: 17,000
- SM31RMHS: 1,800
- SM31RLMHS: 11,000

**ECONO-BEAM Models**

- SE61R: 600
- SE61RMHS: 500

**Other Models**



- SM51RB: 1,200
- Q23SN6R: 400
- Q10AN6R: 250
- Q45BB6R: 9,000

## Accessories

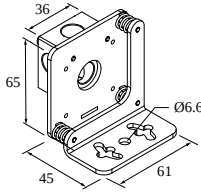
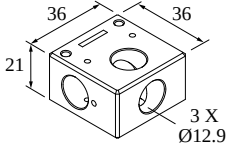
### Mounting Brackets

<p><b>SMB46X3</b></p> <ul style="list-style-type: none"> <li>• Assembly with mounting block and adjustable bracket</li> <li>• Includes:             <ul style="list-style-type: none"> <li>2 mm Shortarm hex key</li> <li>3/64-in Shortarm hex key</li> <li>4 Set screws</li> </ul> </li> </ul>	
<p><b>SMB127</b></p> <ul style="list-style-type: none"> <li>• Mounting block only</li> <li>• Includes:             <ul style="list-style-type: none"> <li>3/64-in Shortarm hex key</li> <li>4 Set screws</li> </ul> </li> </ul>	

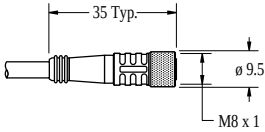
### Quick-Disconnect Cables

3-pin Threaded M8 Cordsets—Single Ended				
Model	Length	Style	Dimensions	Pinout (Female)
PKG3M-2	2.035 m (6.68 ft)	Straight		 <p>1 = Brown 3 = Blue 4 = Black</p>
PKG3M-5	5.035 m (16.51 ft)			
PKG3M-7	7.035 m (23.08 ft)			
PKG3M-9	9.035 m (29.64 ft)			
PKG3M-10	10.035 m (32.92 ft)			

### Retroreflective Tape

Model	Reflectivity Factor	Maximum Temperature	Size
BRT-THG-4X4-5	0.7	+60 °C (+140 °F)	100 × 100 mm (package of 5)
BRT-THG-8.5X11-2	0.7	+60 °C (+140 °F)	216 × 280 mm (package of 2)
BRT-THG-18X36	0.7	+60 °C (+140 °F)	457 × 914 mm (single sheet)