

A

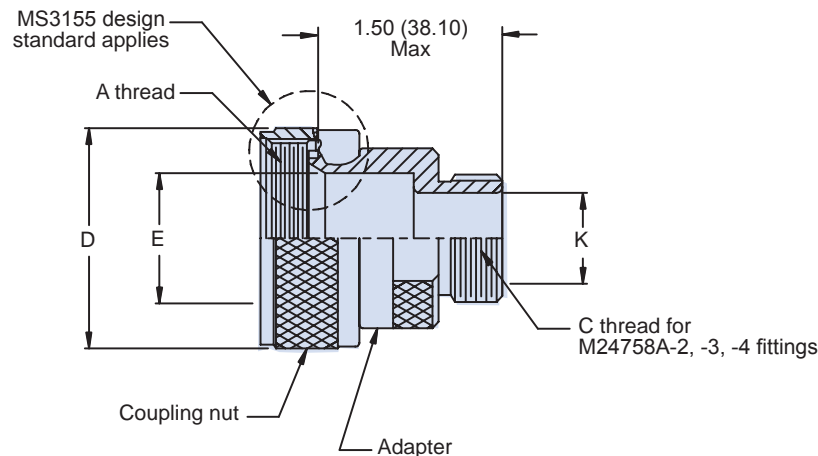
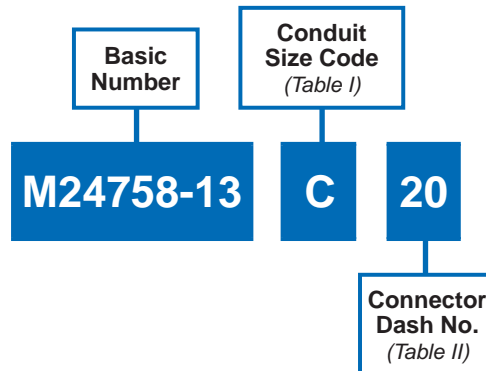

CONDUIT SIZE CODE	C CLASS - 2A THREAD	K DIA MIN
A	.438-28 UNEF	.245 (6.22)
B	.688-24 UNEF	.495 (12.57)
C	.938-20 UNEF	.745 (18.92)
D	1.250-18 UNEF	.995 (25.27)
E	1.563-18 UNEF	1.245 (31.62)
F	1.875-16 UN	1.495 (37.97)
G	2.375-16 UN	1.995 (50.67)
H	2.875-16 UN	2.495 (63.37)
J	.563-24 UNEF	.370 (9.40)
K	.813-20 UNEF	.620 (15.75)
L	3.375-16 UN	2.995 (76.07)

APPLICATION NOTES

1. Assembly identified with manufacturer's code identification number (Glenair, part number and classification code 490).
2. The M24758-13 adapter couples connectors listed in table II to M24758-2, M24758-3 or M24758-4 series conduit fittings.
3. The coupling nut end of this adapter shall conform to military standard MS3155 (Navy), "Connector, electric, rear accessory design standard." MS3155 takes precedence over this specification.
4. The E diameter and M thread of this drawing are the same as the E diameter and M thread of MS3155, and are included for reference purposes.
5. See Glenair Circular Connector Accessories catalog for recommended torque values, Group 2.
6. Material/Finish:
Adapter, coupling nut, 316 / electroless nickel, matte finish.
7. Metric dimensions (mm) are indicated in parentheses.

MIL-PRF-24758-13 Adapter for MS-3155 Type Connectors



MIL-PRF
24758A

A

TABLE II: CONNECTOR DASH NUMBERS AND FITTING DIMENSIONS

CONN DASH NO.	NAS 1599 & MIL-DTL-83723 (SERIES 1 & 3)	MIL-DTL-5015 (MS3400 SERIES)	AS81703 (NAVY) (SERIES 3)	MIL-DTL-26482 (SERIES 2) (MS347X)	A CLASS - 2B THREAD	D DIA MAX	E DIA REF	Y (Style 01) .03 (0.8)
03	--	--	03	--	.562-24 UNEF	.669 (16.99)	.270 (6.86)	.620 (15.7)
08	08	8S	--	08	.500-20 UNF	.617 (15.67)	.270 (6.86)	.620 (15.7)
10	10	10S, 10SL	--	10	.625-24 UNEF	.734 (18.64)	.375 (9.53)	.690 (17.5)
12	12	12, 12S	07	12	.750-20 UNEF	.858 (21.79)	.511 (12.98)	.690 (17.5)
14	14	14, 14S	12	14	.875-20 UNEF	.984 (24.99)	.585 (14.86)	.750 (19.1)
16	16	16, 16S	19	16	1.000-20 UNEF	1.112 (28.24)	.710 (18.03)	.750 (19.1)
18	18	18	27	18	1.062-18 UNEF	1.218 (30.98)	.789 (20.04)	.750 (19.1)
20	20	20	37	20	1.188-18 UNEF	1.345 (34.16)	.914 (23.22)	.810 (20.6)
22	22	22	--	22	1.312-18 UNEF	1.468 (37.29)	1.039 (26.39)	.810 (20.6)
24	24	24	--	24	1.438-18 UNEF	1.593 (40.46)	1.154 (29.31)	.810 (20.6)
28	--	28	--	--	1.750-18 UNS	1.969 (50.01)	1.389 (35.28)	.880 (22.4)
32	--	32	--	--	2.000-18 UNS	2.219 (56.36)	1.635 (41.53)	.880 (22.4)
36	--	36	--	--	2.250-16 UN	2.469 (62.71)	1.850 (46.99)	.880 (22.4)
40	--	40	--	--	2.500-16 UN	2.719 (69.06)	2.065 (52.45)	.940 (23.9)
44	--	44	--	--	2.750-16 UN	2.969 (75.41)	2.320 (58.93)	.940 (23.9)
48	--	48	--	--	3.000-16 UN	3.219 (81.76)	2.570 (65.28)	.940 (23.9)
61	--	--	61	--	1.500-18 UNEF	1.653 (41.99)	1.194 (30.33)	.810 (20.6)