

**M2F60**  
**600V 1.2A**

**特長**

- 小型 SMD
- 耐湿性に優れ高信頼性

**Feature**

- Small SMD
- High-Reliability

**■外観図 OUTLINE**

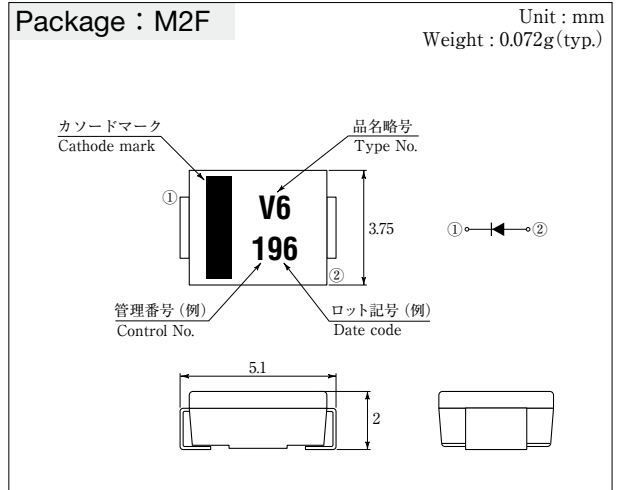

外形図については新電元 Web サイト又は〈半導体製品一覧表〉をご参照下さい。捺印表示については捺印仕様をご確認下さい。  
For details of outline dimensions, refer to our web site or the Semiconductor Short Form Catalog. As for the marking, refer to the specification "Marking, Terminal Connection."

**■定格表 RATINGS**

●絶対最大定格 Absolute Maximum Ratings (指定のない場合は  $T_l = 25^\circ\text{C}$  / unless otherwise specified)

項目 Item	記号 Symbol	条件 Conditions	品名 Type No.	M2F60	単位 Unit
保存温度 Storage Temperature	$T_{stg}$			-55~150	$^\circ\text{C}$
接合部温度 Operation Junction Temperature	$T_j$			150	$^\circ\text{C}$
せん頭逆電圧 Maximum Reverse Voltage	$V_{RM}$			600	V
出力電流 Average Rectified Forward Current	$I_O$	50Hz 正弦波, 抵抗負荷, 50Hz sine wave, Resistance load	プリント基板実装 On glass-epoxy substrate $T_a = 55^\circ\text{C}$	0.9	A
			アルミナ基板実装 On alumina substrate $T_a = 51^\circ\text{C}$	1.2	
せん頭サージ順電流 Peak Surge Forward Current	$I_{FSM}$	50Hz 正弦波, 非繰り返し1サイクルせん頭値, $T_j = 25^\circ\text{C}$ 50Hz sine wave, Non-repetitive 1cycle peak value, $T_j = 25^\circ\text{C}$		50	A
電流二乗時間積 Current Squared Time	$I^2t$	$1\text{ms} \leq t < 10\text{ms}, T_j = 25^\circ\text{C}$		7.4	$\text{A}^2\text{s}$

●電氣的・熱的特性 Electrical Characteristics (指定のない場合は  $T_l = 25^\circ\text{C}$  / unless otherwise specified)

順電圧 Forward Voltage	$V_F$	$I_F = 1.2\text{A}$ , パルス測定 Pulse measurement	MAX 0.97	V
逆電流 Reverse Current	$I_R$	$V_R = 600\text{V}$ , パルス測定 Pulse measurement	MAX 10	$\mu\text{A}$
熱抵抗 Thermal Resistance	$\theta_{jl}$	接合部・リード間 Junction to Lead	MAX 33	$^\circ\text{C}/\text{W}$
	$\theta_{ja}$	接合部・周囲間 Junction to Ambient	MAX 90 MAX 120	

■特性図 CHARACTERISTIC DIAGRAMS

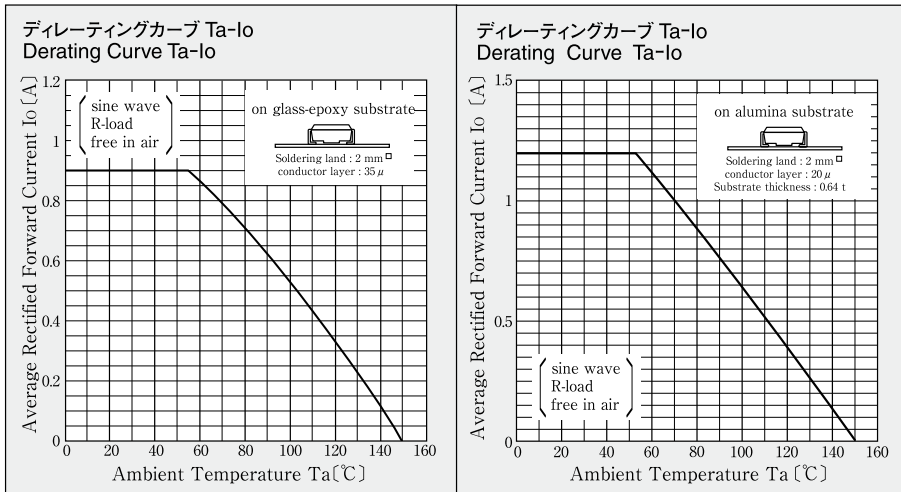
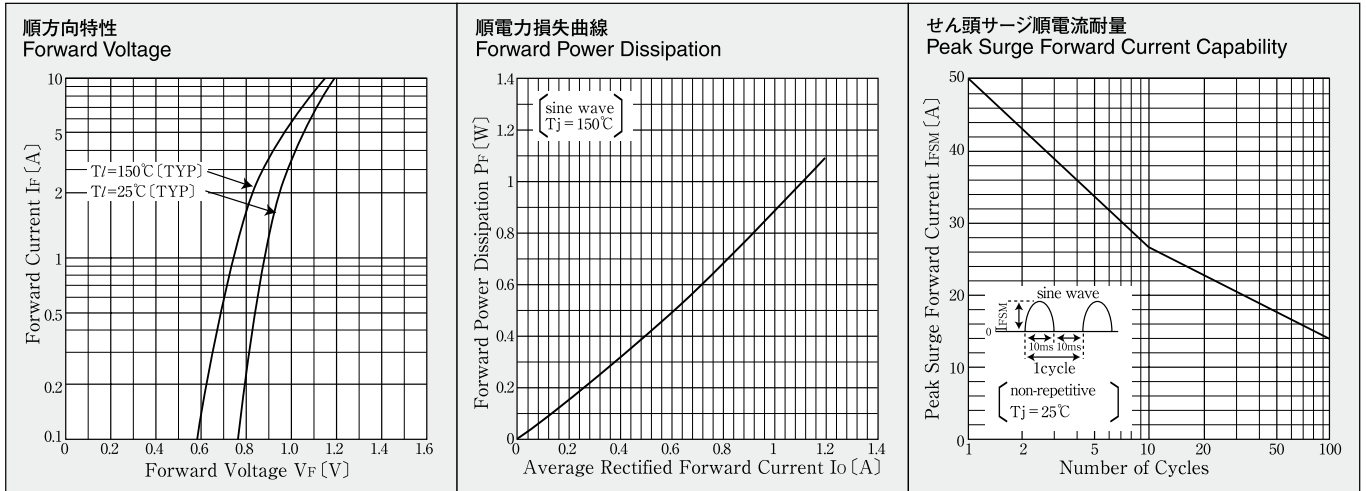

\* Sine wave は 50Hz で測定しています。  
 \* 50Hz sine wave is used for measurements.  
 \* 半導体製品の特性は一般的にバラツキを持っており、Typical は統計的な実力を表しています。  
 \* Semiconductor products generally have characteristic variation. Typical is a statistical average of the device's ability.