

PRODUCT DATA DRAWING

REVISION HISTORY			
REV	DESCRIPTION	DATE	APPROVED
-	DCN 38089	03/11	PJS
A	DCN 42955	01/17	STW

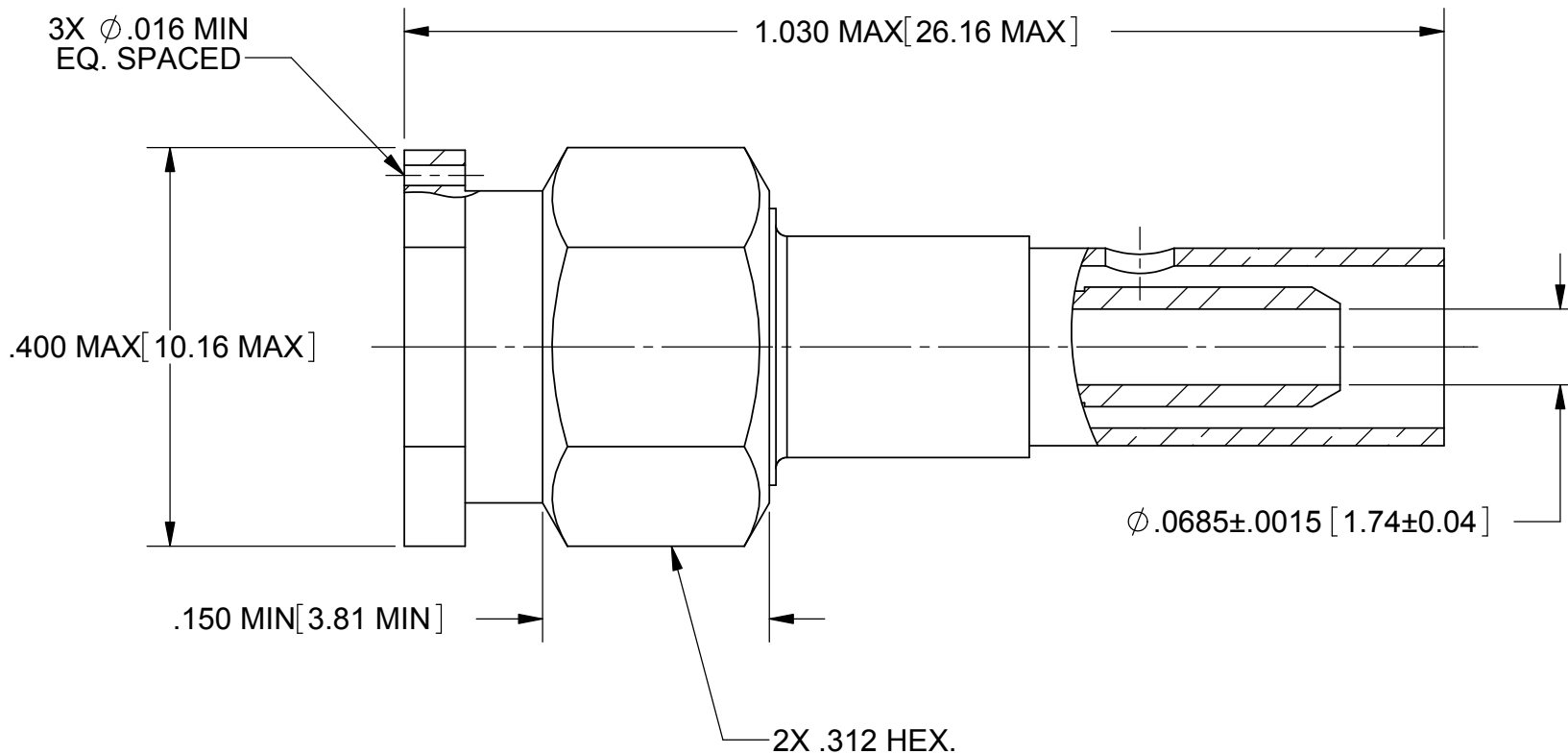
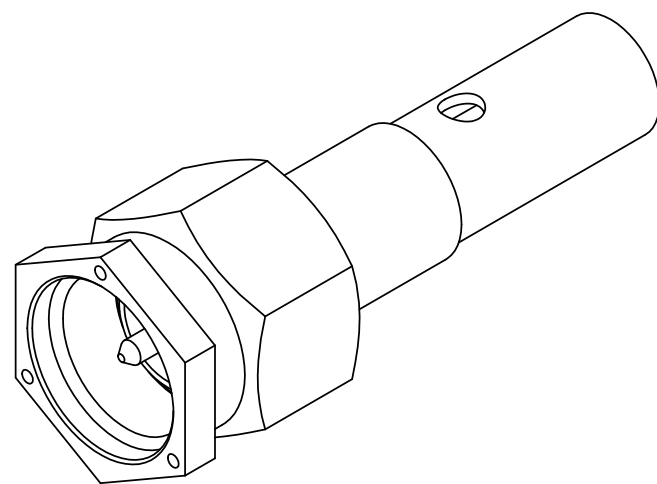

MATERIAL:

- BODY & COUPLING NUT:** STAINLESS STEEL PER AMS-5640, ALLOY UNS S30300, TYPE 1; OR ASTM A582 TYPE 303, COND. A
- CONTACT:** BRASS PER ASTM B16, ALLOY UNS C36000, H02
- LOCK RING:** BERYLLIUM COPPER PER ASTM-B196, ALLOY No. UNS C17300, TD04
- INSULATOR:** PTFE PER ASTM D1710, TYPE I, GRADE 1, CLASS B
- CRIMP RING:** COPPER PER ASTM B301, ALLOY UNS C18700 OR BRASS PER ASTM B16, ALLOY UNS C36000
- GASKET:** SILICONE RUBBER PER A-A-59588, CLASS 2B

FINISH:

- BODY, CONTACT & CRIMP RING:** GOLD PER ASTM B488, TYPE II, CODE C, CLASS 1.27 MIN; OVER NICKEL PER AMS-QQ-N-290, CLASS 1, .00005" MIN
- COUPLING NUT:** PASSIVATED PER AMS 2700

PERFORMANCE:

- IMPEDANCE:** 50 OHMS
- FREQ. RANGE:** DC-12.4 GHz.
- INSERTION LOSS:** .06 X SQRT(F IN GHz)
- VSWR:** 1.15+.02*F DC TO 12.4 GHz.
- TEMP. RANGE:** -65°C TO +165°C

MATERIAL: SEE NOTES	DIMENSIONS ARE IN INCHES TOLERANCES: FRACTIONAL: \pm 1/64 ANGULAR: X° \pm 1'0" X*X' \pm 15'	UNLESS OTHERWISE SPECIFIED 1) ALL DIMENSIONS ARE IN INCHES (MILLIMETERS) 2) ALL DIMENSIONS ARE AFTER PLATING. 3) BREAK CORNERS & EDGES .005 R. MAX. 4) CHAM. 1ST & LAST THREADS. 5) SURFACE ROUGHNESS 63-MIL-STD-10. 6) DIA.'S ON COMMON CENTERS TO BE CONCENTRIC WITHIN .005 T.I.R. 7) REMOVE ALL BURRS	SV Microwave, Inc. 2400 Centrepark West Drive, Suite 100 West Palm Beach, FL 33409
FINISH: SEE NOTES	DECIMAL: .X \pm .030 .XX \pm .010 .XXX \pm .005	INTERPRET DIMENSIONS AND TOLERANCES PER ASME Y14.5M - 1994	TITLE: SMA STRAIGHT SOLDER PLUG FOR M17/152-00001 CABLE
SURFACE AREA: N/A	THIRD ANGLE PROJECTION	DRAWN: FED 03/29/11	SIZE: B CAGE CODE: 95077 DWG. NO. M39012/55-3030
PROPRIETARY THE INFORMATION CONTAINED IN THIS DRAWING IS THE SOLE PROPERTY OF SV MICROWAVE, INC. ANY REPRODUCTION IN PART OR AS A WHOLE WITHOUT THE WRITTEN PERMISSION OF SV MICROWAVE, INC IS PROHIBITED.		CHECKED: PJS 03/29/11 APPROVED: PJS 03/29/11	SCALE: 6:1 SHEET 1 OF 1