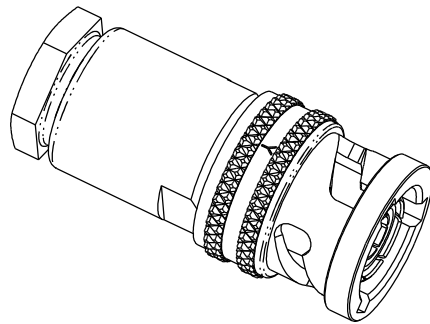
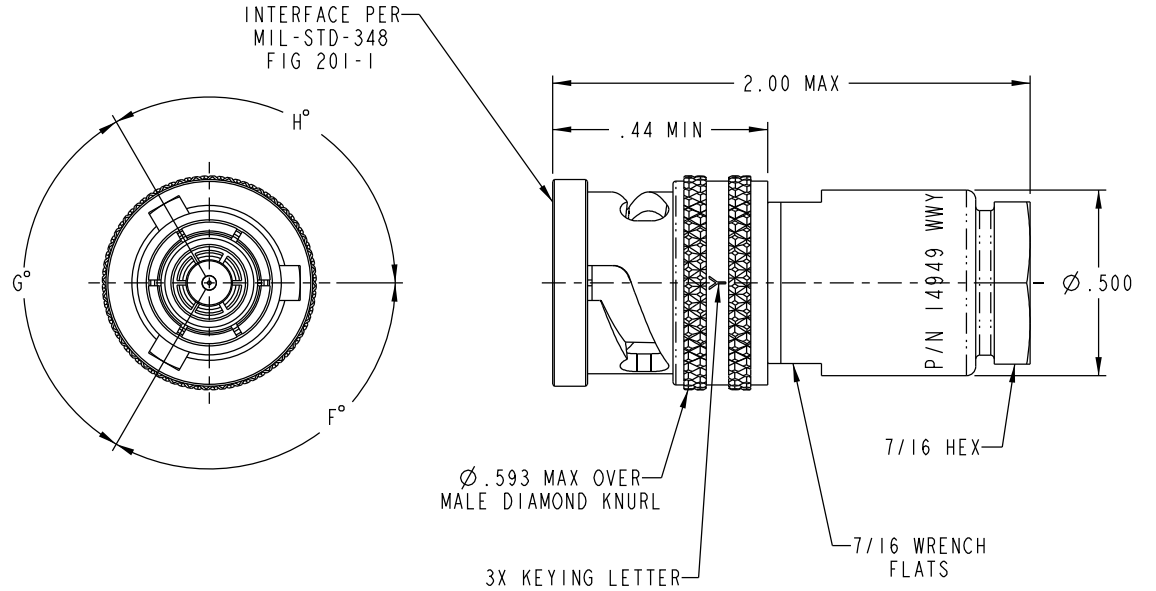

TABLE 1						
MILITARY PART NUMBER	MILITARY CABLE NUMBER	TEI DASH #	KEYING LETTER	ASSEMBLE PER	CABLE TYPE	NSN #
M49142/03-0001	M17/134-00001 M17/134-00003	7	NONE	TAI-189	TRIAx	5935011636242
M49142/03-0101	M17/134-00001 M17/134-00003	7	Y	TAI-189	TRIAx	---
M49142/03-0201	M17/134-00001 M17/134-00003	7	S	TAI-189	TRIAx	---
M49142/03-0002	M17/134-00002 M17/134-00004	7	NONE	TAI-189	TRIAx	5935014397867
M49142/03-0102	M17/134-00002 M17/134-00004	7	Y	TAI-189	TRIAx	---
M49142/03-0202	M17/134-00002 M17/134-00004	7	S	TAI-189	TRIAx	---
M49142/03-0005	M17/116-RG307	41A	NONE	TAI-250	TRIAx	5935014238648
M49142/03-0105	M17/116-RG307	41A	Y	TAI-250	TRIAx	---
M49142/03-0205	M17/116-RG307	41A	S	TAI-250	TRIAx	---
M49142/03-0007	M17/45-RG108 M17/186-00008	9	NONE	TAI-102	TWINAX	5935013358935
M49142/03-0107	M17/45-RG108 M17/186-00008	9	Y	TAI-102	TWINAX	---
M49142/03-0207	M17/45-RG108 M17/186-00008	9	S	TAI-102	TWINAX	---
M49142/03-0008	M17/176-00002	47	NONE	TAI-102	TWINAX	5935013783905
M49142/03-0108	M17/176-00002	47	Y	TAI-102	TWINAX	5935014277109
M49142/03-0208	M17/176-00002	47	S	TAI-102	TWINAX	---
M49142/03-0009	M17/177-00001	60	NONE	TAI-189	TRIAx	5935014675369
M49142/03-0109	M17/177-00001	60	Y	TAI-189	TRIAx	5935014675370
M49142/03-0209	M17/177-00001	60	S	TAI-189	TRIAx	---

TABLE 2			
KEYING LETTER	F°	G°	H°
NONE	120	120	120
Y	110	140	110
S	135	135	90

REVISIONS			
REV	DESCRIPTIONS	DATE	APPROVED
BU	ECO 54729	9/25/13	C. MONAHAN

DATA CONTAINED IN THIS DOCUMENT IS PROPRIETARY TO CINCH CONNECTIVITY SOLUTIONS AND SHALL NOT BE DISCLOSED, COPIED OR USED FOR PROMOTION OR MANUFACTURE WITHOUT EXPRESS WRITTEN PERMISSION



NOTES: UNLESS OTHERWISE SPECIFIED.

INTERPRET DRAWING PER MIL-STD-100: DIMENSIONS ARE IN INCHES AND INCLUDE FINISH THICKNESS UNLESS OTHERWISE SPECIFIED.		TOL: UNLESS SPECIFIED: .XX ± .02 .XXX ± .010 .XXXX ± .000 ANGLE ± 1° 00'	
DRN: C. WALLACE	DATE: 9/25/13	MATERIAL:	TITLE: M49142/03 WRENCH CRIMP PLUG
CHK: C. MONAHAN	DATE: 10/14/14	FINISH:	SIZE: B
QUALITY:			CAGE CODE: 14949
MANUF:			DRAWING NO.: 310-0083
APPROVED:			DATE: 9/25/13
SURFACE AREA:	PROJ FILE NO: 310-0083	DO NOT SCALE DWG	SCALE: 3/1
			DATE: 9/25/13
			SHEET: 1 OF 2

