

## Load Insensitive Mixer

Rev. V3

### Features

- LO 1 TO 3400 MHz
- RF 1 TO 3400 MHz
- IF 1 TO 2000 MHz
- LO DRIVE: +23 dBm (NOMINAL)
- INSENSITIVE TO SYSTEM MISMATCH
- HIGH INTERCEPT: +29 dBm (TYP.)
- AVAILABLE IN SURFACE MOUNT

### Description

The M4TH is a termination insensitive mixer, designed for use in military, commercial and test equipment applications. The design utilizes Schottky bridge quad diodes, broadband ferrite baluns and internal loads to provide excellent performance without degradation due to external VSWR mismatches. The use of high temperature solder and welded assembly processes used internally makes it ideal for use in semi-automated and automated assembly. Environmental screening available to MIL-STD-883, MIL-STD-202, or MIL-DTL-28837, consult factory.

### Product Image

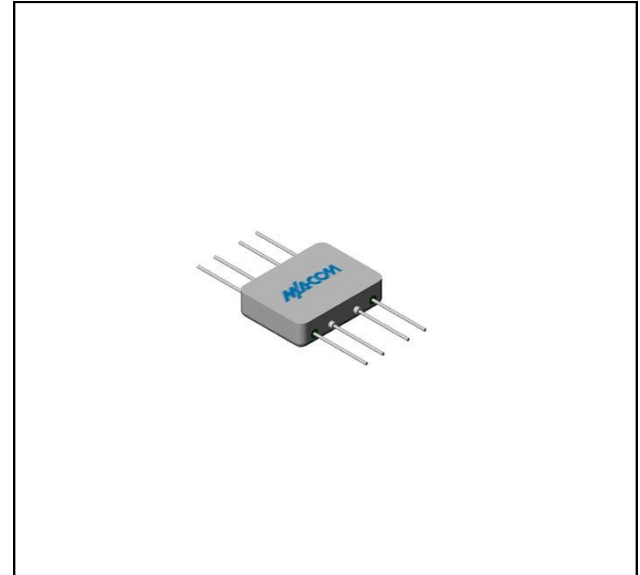

### Ordering Information

Part Number	Package
M4TH	Flatpack

### Electrical Specifications: $Z_0 = 50\Omega$ $Lo = +23$ dBm (Downconverter application only)

Parameter	Test Conditions	Units	Typical	Guaranteed	
				+25°C	-54° to +85°C
SSB Conversion Loss (max) & SSB Noise Figure (max)	fR = 0.005 to 2.0 GHz, fL = 0.005 to 2.0 GHz, fl = 0.001 to 0.5 GHz fR = 0.001 to 3.4 GHz, fL = 0.001 to 3.4 GHz, fl = 0.001 to 2.0 GHz	dB	7.0	8.0	8.3
			9.0	10.5	10.8
Isolation, L to R (min)	fL = 0.01 to 1.5 GHz fL = 0.01 to 3.4 GHz	dB	35	30	29
			35	22	21
Isolation, L to I (min)	fL = 0.01 to 1.5 GHz fL = 0.01 to 3.4 GHz	dB	40	30	29
			35	25	24
Isolation, R to I (min)	fR = 0.001 to 3.4 GHz	dB	21		
1 dB Conversion Comp.	fL = +23 dBm	dBm	+17		
Input IP3	fR1 = 2 GHz at 0 dBm, fR2 = 2.01 GHz at 0 dBm, fL = 1.9 GHz at +23 dBm	dBm	+29		

## Load Insensitive Mixer

Rev. V3

### Typical Performance Curves

Conversion Loss vs. Frequency

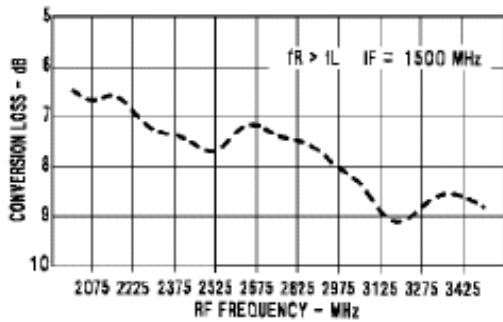
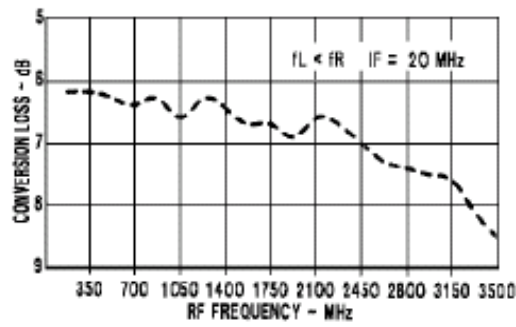

### Outline Drawing: Flatpack \*

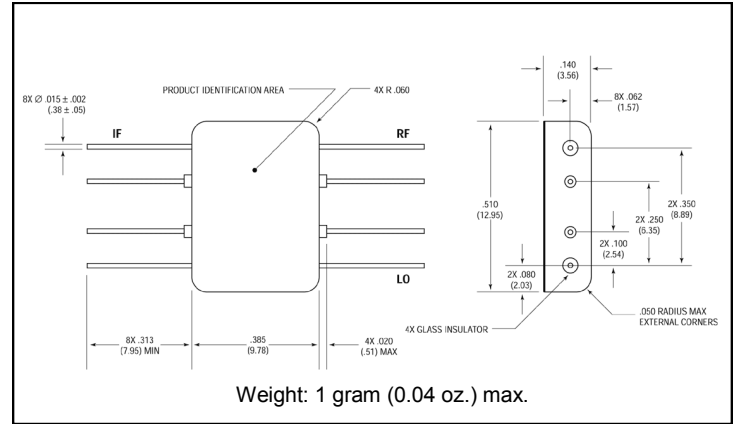

### Absolute Maximum Ratings

Parameter	Absolute Maximum
Operating Temperature	-54°C to +100°C
Storage Temperature	-65°C to +100°C
Peak Input Power	+27 dBm max @ +25°C +23 dBm max @ +100°C
Peak Input Current	50 mA DC