

**B** AJ-156-CP

PART #	MILITARY PART #	CABLE Ø	BUSHING	WASHER	SPRING
AJ-156/12-1	M55116/12-1	.165±.010	AP-116-17	AP-116-2	AP-116-4
AJ-156/12-2	M55116/12-2	.228±.010	AP-116-18	AP-116-2	AP-116-4
AJ-156/12-3	M55116/12-3	.250±.010	AP-116-8	AP-116-2	AP-116-4
AJ-156/12-4	M55116/12-4	.290±.010	AP-116-19	AP-116-2	AP-116-4
AJ-156/12-5	M55116/12-5	.320±.010	AP-116-20	AP-116-22	AP-116-21

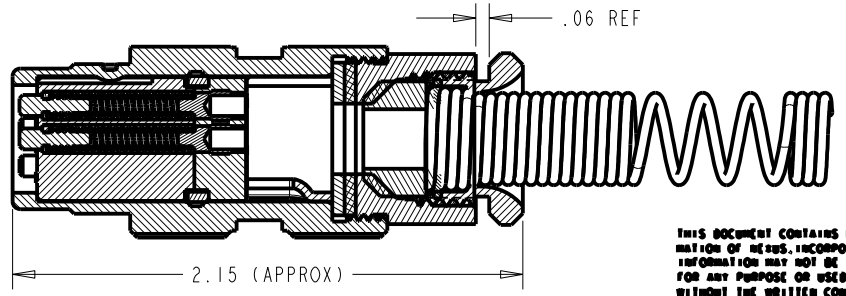
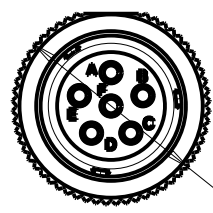
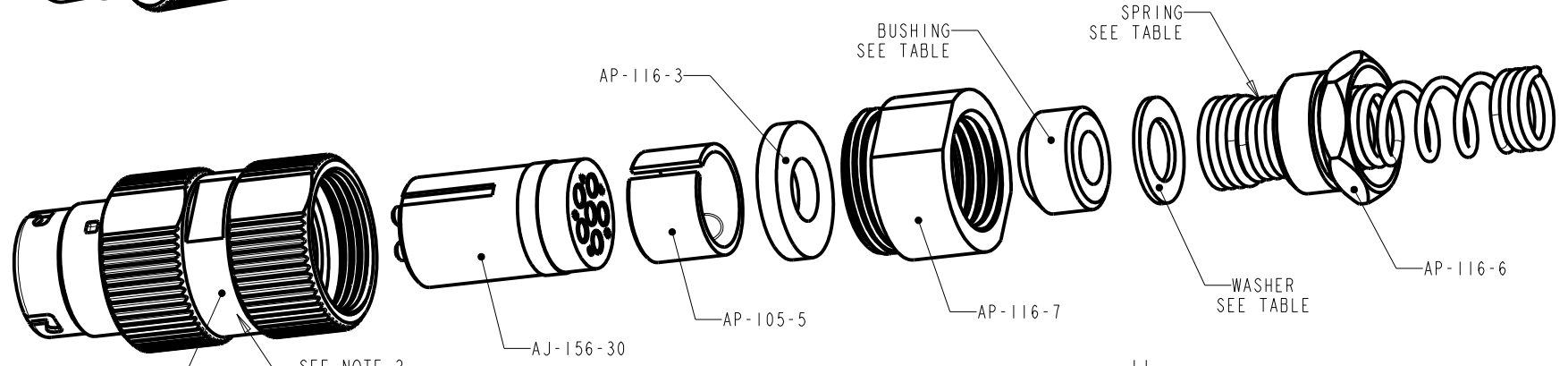
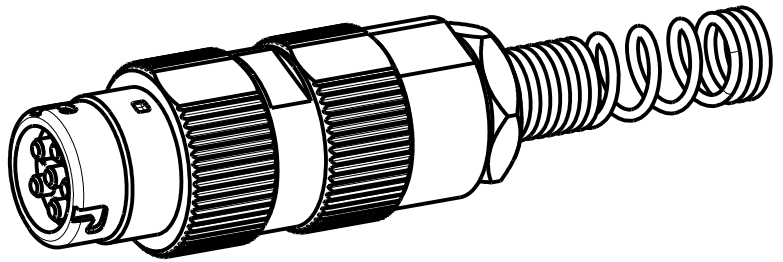

THIS DOCUMENT CONTAINS PROPRIETARY INFORMATION OF NEXUS, INCORPORATED AND SUCH INFORMATION MAY NOT BE DISCLOSED TO OTHERS FOR ANY PURPOSE OR USED FOR ANY PURPOSE WITHOUT THE WRITTEN CONSENT OF NEXUS.

NOTES:  
 1. CONNECTORS ARE QUALIFIED TO MIL-DTL-55116.  
 2. MARK MILITARY PART IDENTIFYING NO., MANUFACTURERS NAME AND CAGE CODE LOCATED APPROXIMATELY AS SHOWN.

REV.	REVISION	CR #	DATE	COM.
B	ADD P/N TO TABLE	111	8/1 2011	HR
A	ADD NOTES AND TABLE	036	12/15/09	GPH

OWN. BY	DATE	MATERIAL	
CHECKED BY	DATE	FINISH	
APP. BY	DATE	WEIGHT	SCALE = 2.00 : 1
UNLESS OTHERWISE SPECIFIED DIMENSIONS ARE IN INCHES TOLERANCES ON		TITLE	
.XX SEE ANGLES		JACK, 6 PIN AUDIO, CRIMP SLEEVE	
.003 SEE ANGLES		DO NOT SCALE DWG. SHEET 1 OF 1	
SIZE		Dwg. no.	
B		AJ-156-CP	

**NEXUS**  
STAMFORD, CONN