

C AP-126

| ITEM # | PART #       | QTY | DESCRIPTION   | MATERIAL                                       |
|--------|--------------|-----|---------------|--|
| 1      | SEE TABLE #1 | 1   | SHELL ASS'Y   | GLASS FILLED NYLON & 303 SS                    |
| 2      | AP-126-6     | 1   | INSERT ASS'Y  | DIALLYPHTHALATE, TYPE SDGF & GOLD PLATED BRASS |
| 3      | AP-105-5     | 1   | STRAIN RELIEF | NYLON  |
| 4      | AP-116-3     | 1   | WASHER        | RUBBER   |
| 5      | AP-116-7     | 1   | NUT ADAPTER   | ALUMINUM, ANODIZED                             |
| 6      | SEE TABLE #1 | 1   | BUSHING       | RUBBER   |
| 7      | SEE TABLE #1 | 1   | WASHER        | STAINLESS STEEL                                |
| 8      | SEE TABLE #1 | 1   | SPRING        | 302 STAINLESS STEEL                            |
| 9      | AP-116-6     | 1   | STUD          | ALUMINUM ALLOY, ANODIZED                       |

| TABLE #1     |                 |             |               |           |           |           |
|--------------|-----------------|-------------|---------------|-----------|-----------|-----------|
| AUDIO PLUG # | MILITARY PART # | SHELL ASS'Y | CABLE SIZE    | BUSHING   | WASHER    | SPRING    |
| AP-126/2-1   | M55116/2-1      | AP-126-1    | ∅ .185 ± .010 | AP-116-17 | AP-116-2  | AP-116-4  |
| AP-126/2-2   | M55116/2-2      | AP-126-2    | ∅ .228 ± .010 | AP-116-18 | AP-116-2  | AP-116-4  |
| AP-126/2-3   | M55116/2-3      | AP-126-3    | ∅ .250 ± .010 | AP-116-8  | AP-116-2  | AP-116-4  |
| AP-126/2-4   | M55116/2-4      | AP-126-4    | ∅ .290 ± .010 | AP-116-19 | AP-116-2  | AP-116-4  |
| AP-126/2-5   | M55116/2-5      | AP-126-5    | ∅ .320 ± .010 | AP-116-20 | AP-116-22 | AP-116-21 |

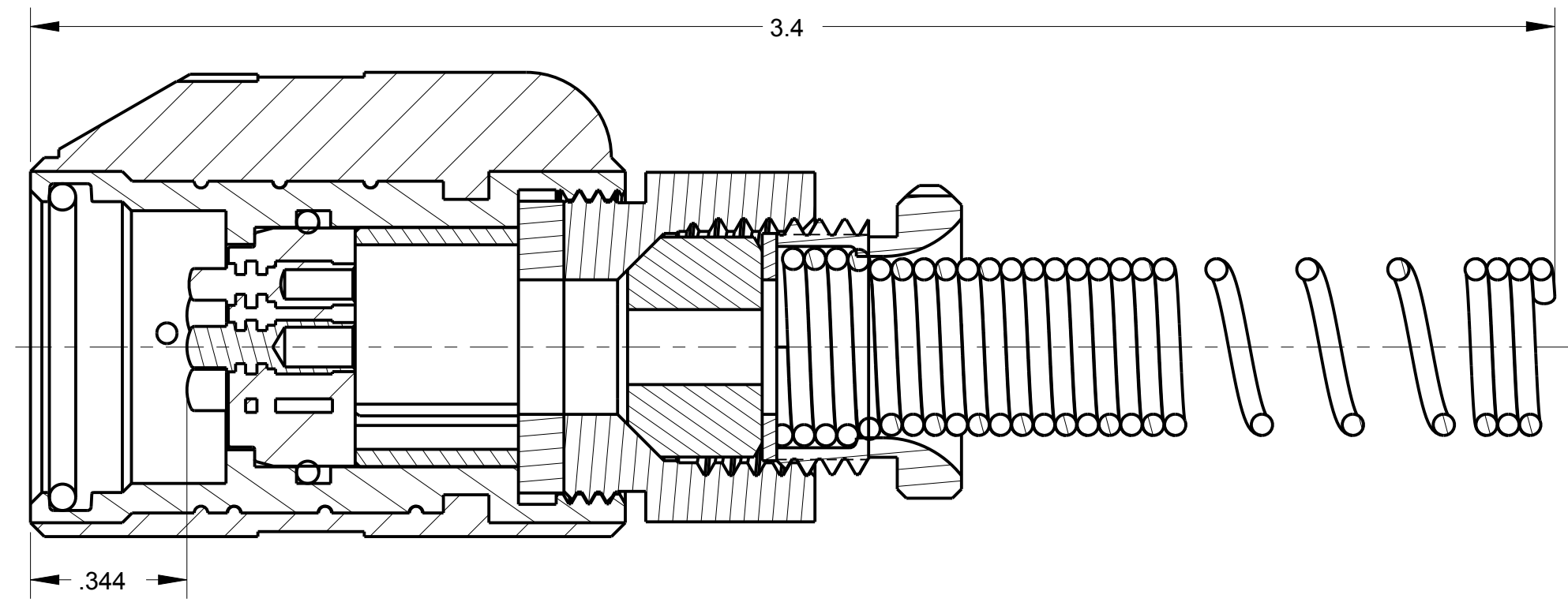
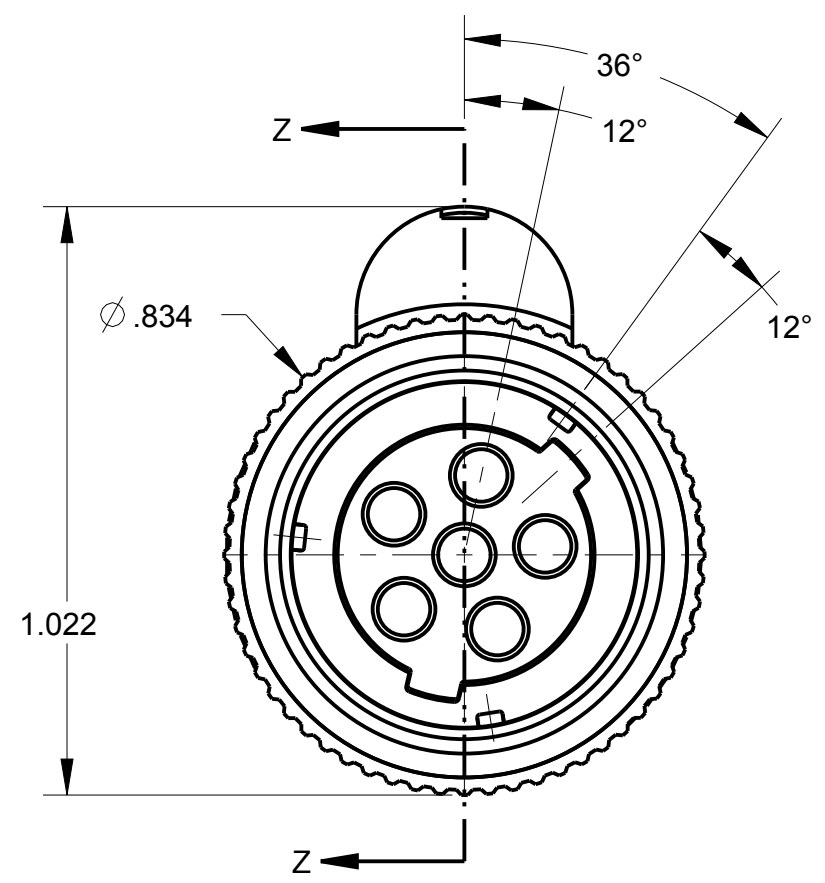
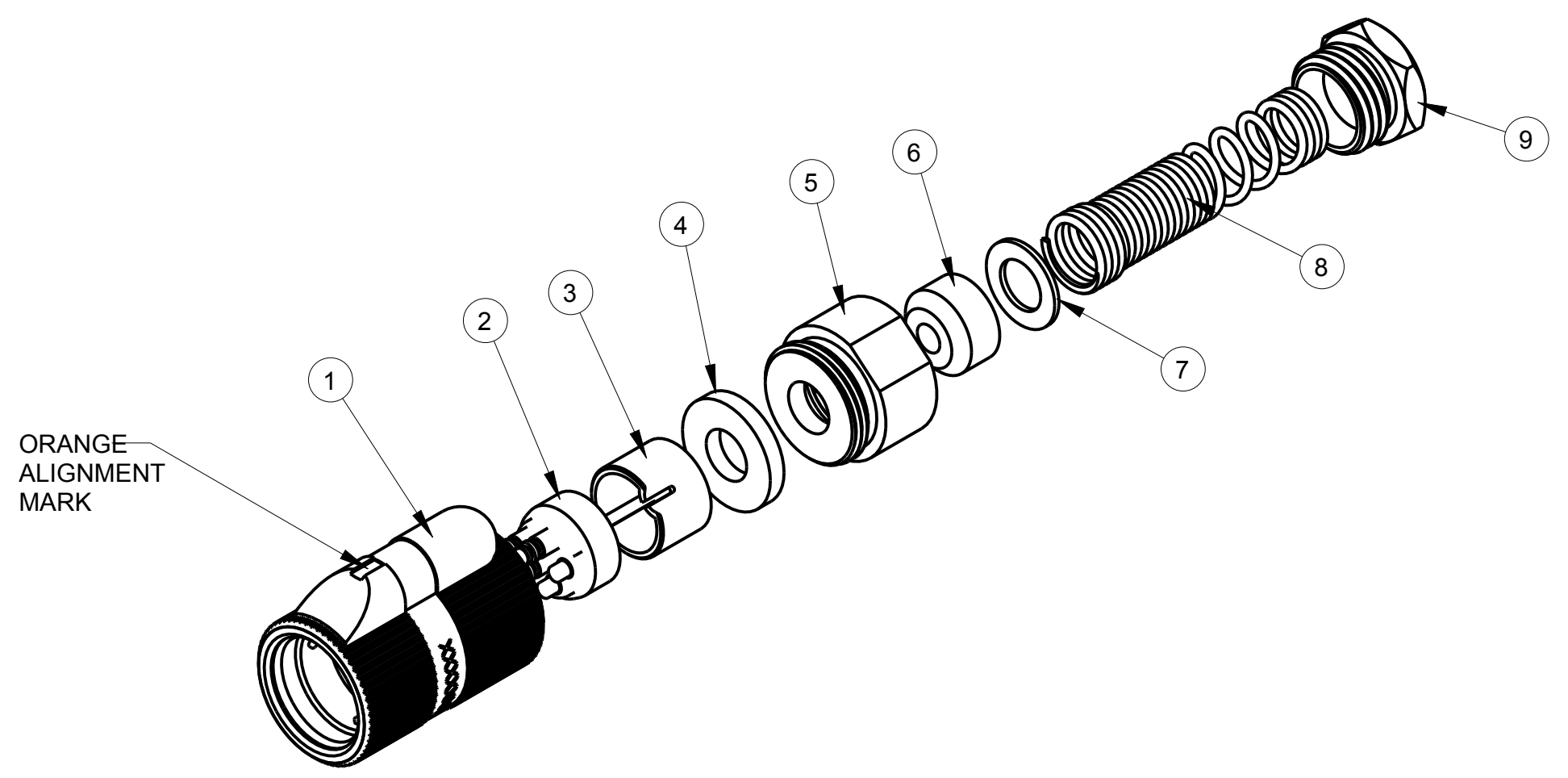

SECTION Z-Z

NOTES:  
 1) UNLESS OTHERWISE SPECIFIED, CONNECTOR MEETS ALL GENERAL REQUIREMENTS & SPECIFICATIONS OF MIL-C-55116

THIS DOCUMENT CONTAINS PROPRIETARY INFORMATION OF NEXUS, INCORPORATED AND SUCH INFORMATION MAY NOT BE DISCLOSED TO OTHERS FOR ANY PURPOSE OR USED FOR ANY PURPOSE WITHOUT THE WRITTEN CONSENT OF NEXUS.

|      |                          |      |           |     |  |                |                              |
|------|--------------------------|------|-----------|-----|--|----------------|------------------------------|
|      |                          |      |           |     | DWN. BY<br>MNF   | DATE<br>2/4/97 | MATERIAL                     |
|      |                          |      |           |     | CHECKED BY<br>L SMITH  | DATE<br>9/9/97 | FINISH                       |
|      |                          |      |           |     | APPR. BY<br>L SMITH  | DATE<br>9/9/97 | WEIGHT _____ SCALE = 1.00 :1 |
| C    | REVISE TABLE #1          | 111  | 8/1 2011  | HR  | UNLESS OTHERWISE SPECIFIED DIMENSIONS ARE IN INCHES & OR [mm] TOLERANCES:<br>DECIMAL: ±.XX[X.X] ±.XXX[XX] ±.01[0.3] ±.003[0.08]<br>FRACTION: ±XXX ± 1/64 ANGLES: ±X ° ±5 ° |                | TITLE<br><b>AUDIO PLUG</b>   |
| B    | ADD P/N'S IN P/L         | 101  | 2/25 2011 | HR  | DO NOT SCALE DWG. SHEET 1 OF 1   |                |                              |
| A    | REVISED & REDRAWN ON CAD | 0259 | 2/24 1997 | LS  | NEXUS STAMFORD, CONN.  |                |                              |
| LET. | REVISION                 | CN # | DATE      | CHK | SIZE DWG. NO.<br><b>C</b> AP-126   |                |                              |