

ITEM #	PART #	QTY	DESCRIPTION	MATERIAL
1	SEE TABLE #1	1	SHELL ASS'Y	GLASS FILLED NYLON & 303 SS
2	AP-125-6	1	INSERT ASS'Y	DIALLYPHTHALATE, TYPE SDGF & GOLD PLATED BRASS
3	AP-105-5	1	STRAIN RELIEF	NYLON
4	AP-105-6	1	FERRULE	STAINLESS STEEL
5	AP-105-8	1	NUT CLAMP	NYLON, BLACK PER MIL-P-17091

C AP-155-CP

TABLE #1			
AUDIO PLUG #	MILITARY PART #	SHELL ASS'Y	Ø CABLE
AP-155/5-1	M55116/5-1	AP-155-1	Ø .165 ± .010
AP-155/5-2	M55116/5-2	AP-155-2	Ø .228 ± .010
AP-155/5-3	M55116/5-3	AP-155-3	Ø .250 ± .010
AP-155/5-4	M55116/5-4	AP-155-4	Ø .290 ± .010
AP-155/5-5	M55116/5-5	AP-155-5	Ø .320 ± .010

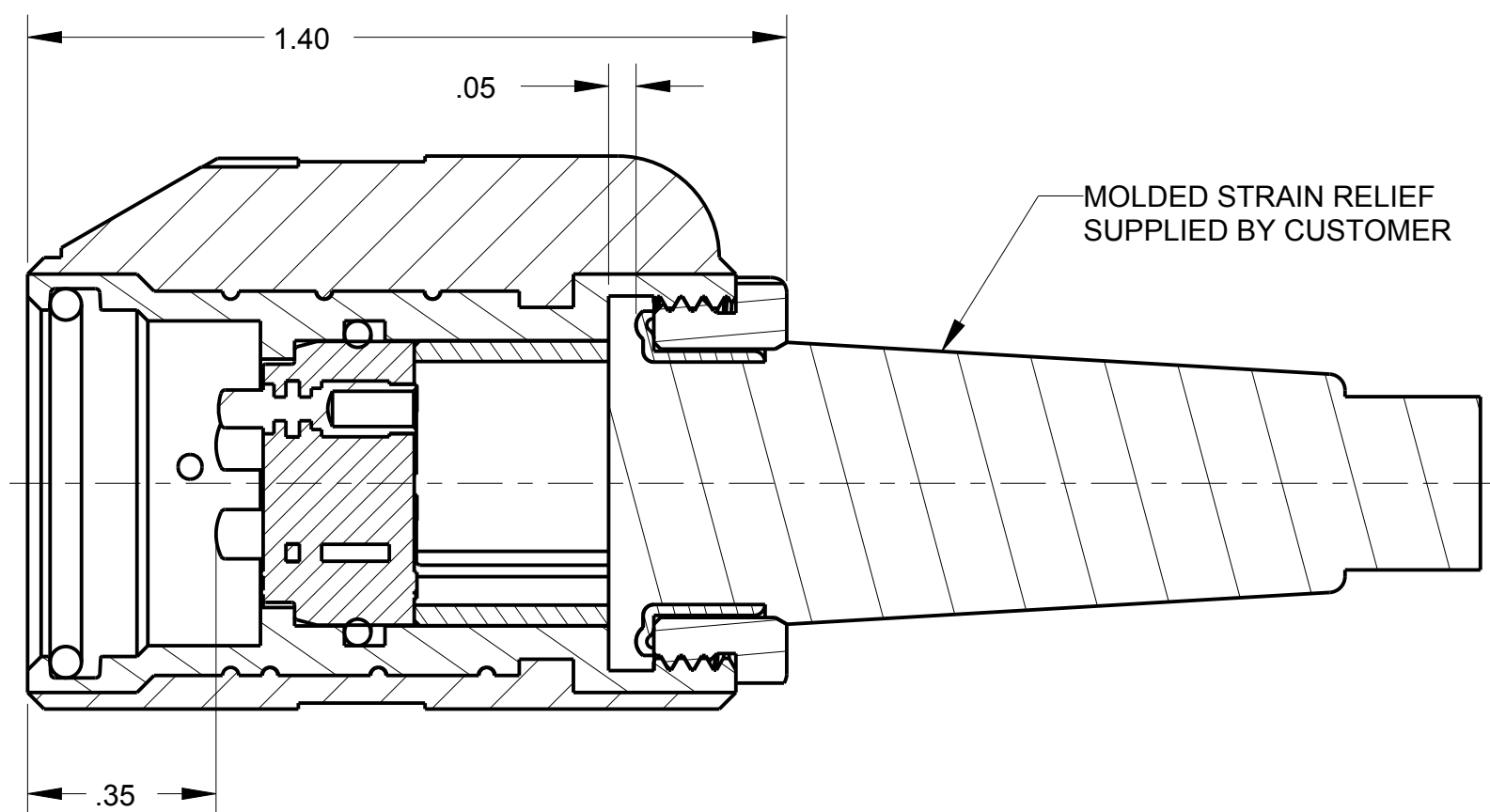
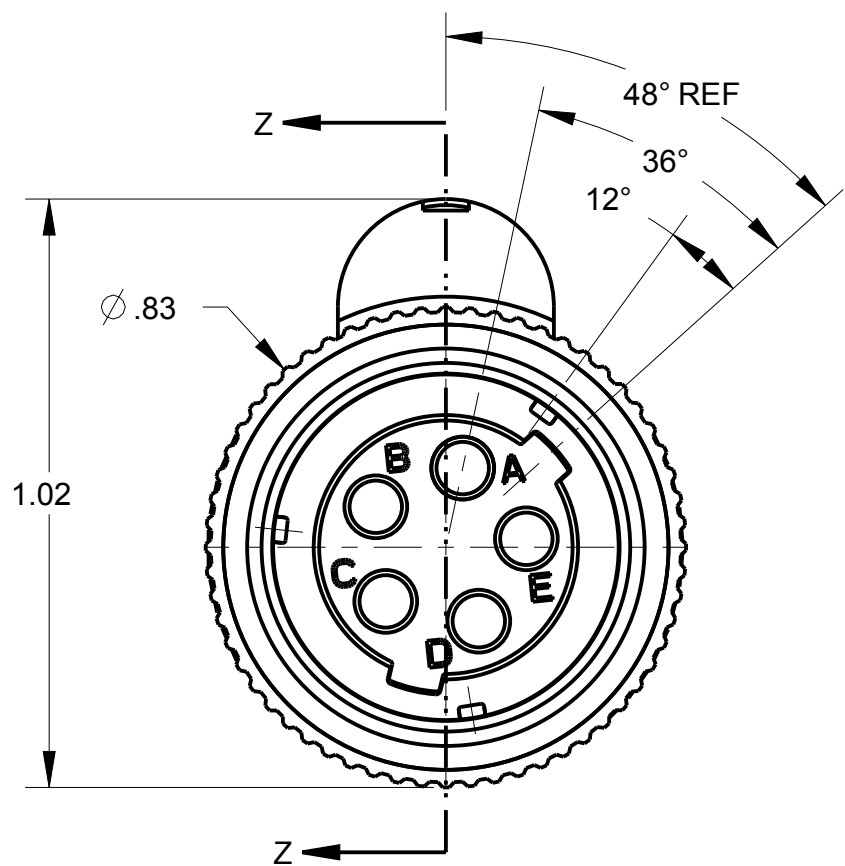
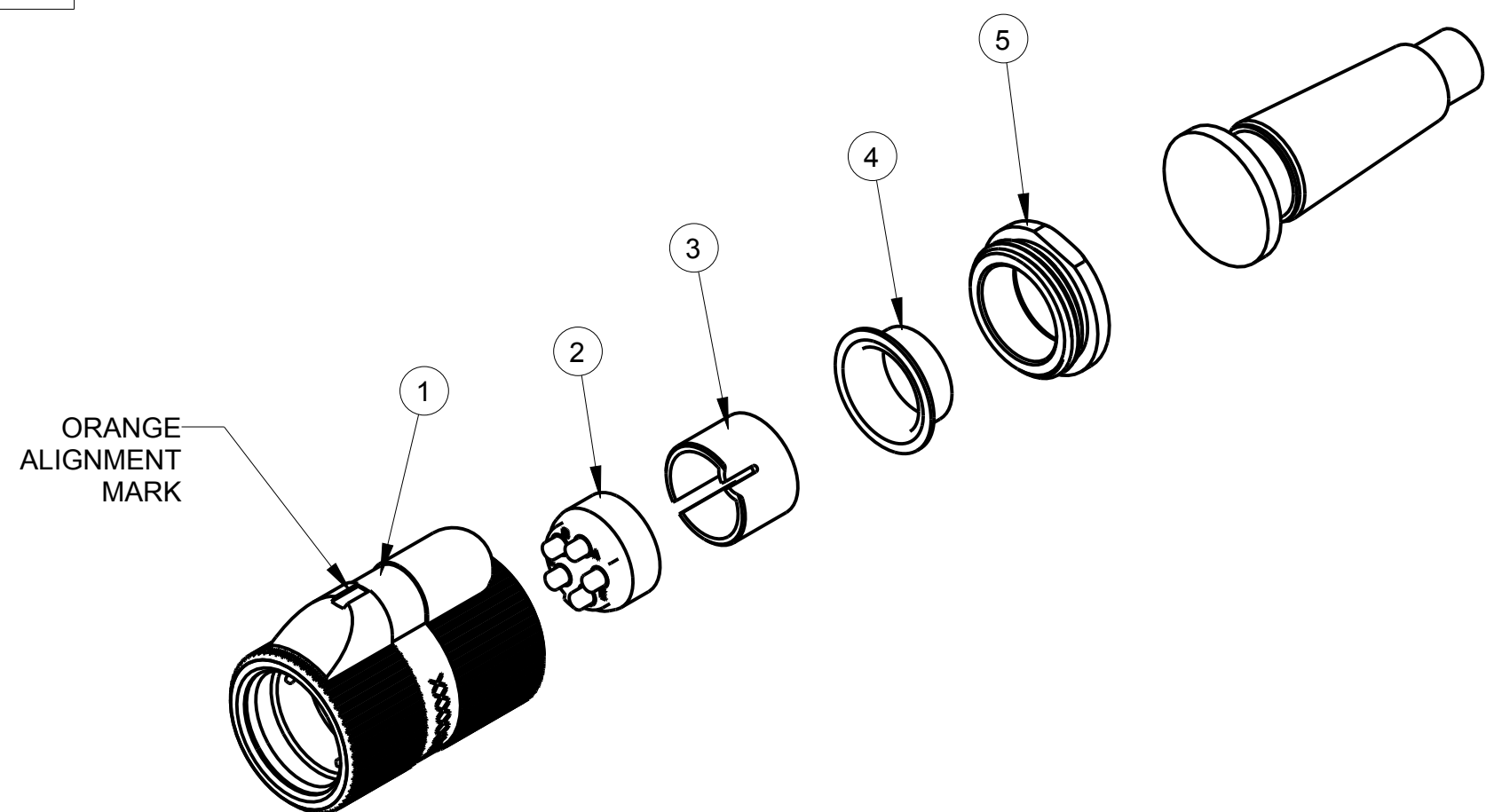

SECTION Z-Z

NOTES:
 1) UNLESS OTHERWISE SPECIFIED, CONNECTOR MEETS ALL GENERAL REQUIREMENTS & SPECIFICATIONS OF MIL-C-55116

THIS DOCUMENT CONTAINS PROPRIETARY INFORMATION OF NEXUS, INCORPORATED AND SUCH INFORMATION MAY NOT BE DISCLOSED TO OTHERS FOR ANY PURPOSE OR USED FOR ANY PURPOSE WITHOUT THE WRITTEN CONSENT OF NEXUS.

DWN BY	MNF	DATE	2/4/97	MATERIAL
CHECKED BY	L SMITH	DATE	9/9/97	FINISH
APPR BY	L SMITH	DATE	9/9/97	WEIGHT
UNLESS OTHERWISE SPECIFIED DIMENSIONS ARE IN INCHES & OR (mm)				SCALE = 1.00 :1
TOLERANCES:				TITLE AUDIO PLUG
DECIMAL:				
±.XX(X.X) ±.XXX(X.XX) ±.XXXX(X.XXX)				
FRACTION: ±X/XX ±X/XX				DO NOT SCALE DWG.
ANGLES: ±X° ±X'				SHEET 1 OF 1
LET.	REVISION	CN #	DATE	CHK
C	ADD: AP-155/5-2; /5-3, /5-4, & /5-5; 36°, 48° REF, DEL. 12°, 36°	226	8/12 2015	HR
B	ADD P/N's IN P/L	101	2/25 2011	HR
A	REVISED & REDRAWN ON CAD	0259	2/24 1997	LS

NEXUS
 STAMFORD, CONN
 SIZE C DWG. NO. AP-155-CP