

Quad bus buffer (3-state)

Datasheet - production data

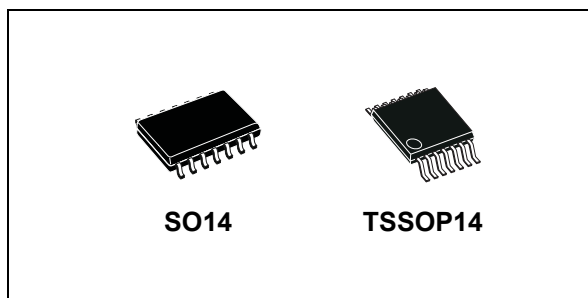

- Balanced propagation delays:
 $t_{PLH} \cong t_{PHL}$
- Wide operating voltage range:
 $V_{CC} \text{ (opr)} = 2 \text{ V to } 6 \text{ V}$
- Pin and function compatible with 74 series 126
- ESD performance
 - CDM: 1 kV
 - HBM: 2 kV
 - MM: 200 V

Features

- High-speed:
 $t_{PD} = 8 \text{ ns (typ.) at } V_{CC} = 6 \text{ V}$
- Low power dissipation:
 $I_{CC} = 4 \mu\text{A (max.) at } T_A = 25 \text{ }^\circ\text{C}$
- High noise immunity:
 $V_{NIH} = V_{NIL} = 28 \% V_{CC} \text{ (min)}$
- Symmetrical output impedance:
 $|I_{OH}| = I_{OL} = 6 \text{ mA (min.)}$

Description

The M74HC126 is a high-speed CMOS quad buffer (3-state) fabricated with silicon gate C²MOS technology.

The device requires the 3-state control input, G, to be set high to place the output into high impedance state.

All inputs are equipped with protection circuits against static discharge and transient excess voltage.

Table 1. Device summary

Order code	Temp. range	Package	Packaging	Marking
M74HC126RM13TR	-55 °C to 125 °C	S014	Tape and reel	74HC126
M74HC126YRM13TR ⁽¹⁾	-40 °C to 125 °C	SO14 (automotive grade)		74HC126Y
M74HC126TTR	-55 °C to 125 °C	TSSOP14		HC126
M74HC126YTTR ⁽¹⁾	-40 °C to 125 °C	TSSOP14 (automotive grade)		HC126Y

1. Qualification and characterization according to AEC Q100 and Q003 or equivalent, advanced screening according to AEC Q001 and Q002 or equivalent.

Contents

1	Pin information	3
2	Functional description	4
3	Electrical characteristics	5
4	Package information	10
	4.1 SO14 package information	11
	4.2 TSSOP14 package information	12
5	Ordering information	13
6	Revision history	13

1 Pin information

Figure 1. Pin connection and IED logic symbols

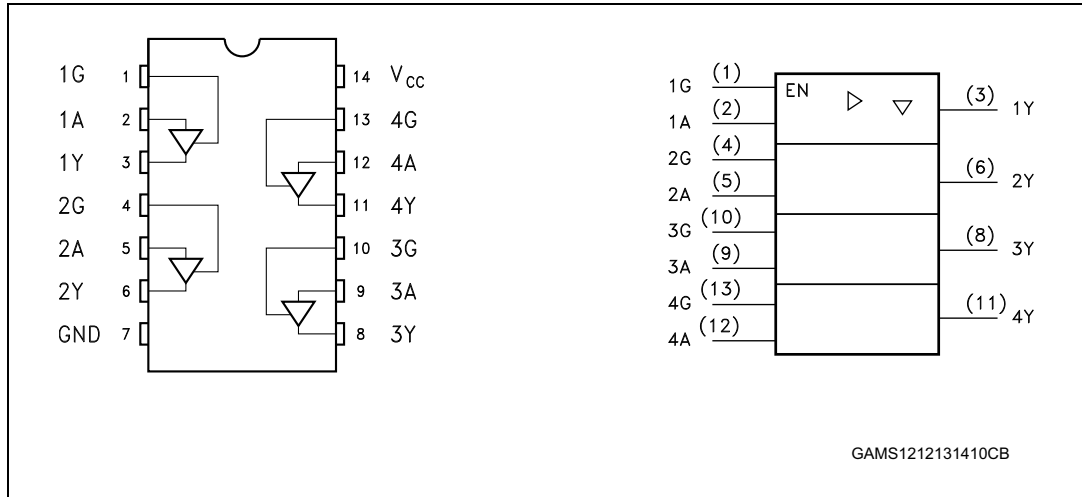

Table 2. Pin description

Pin no	Symbol	Name and function
1, 4, 10, 13	1G to 4G	Output enable input
2, 5, 9, 12	1A to 4A	Data inputs
3, 6, 8, 11	1Y to 4Y	Data outputs
7	GND	Ground (0 V)
14	V _{CC}	Positive supply voltage

2 Functional description

Table 3. Truth table

A	G	Y
X	L	Z
L	H	L
H	H	H

Figure 2. Input and output equivalent circuit

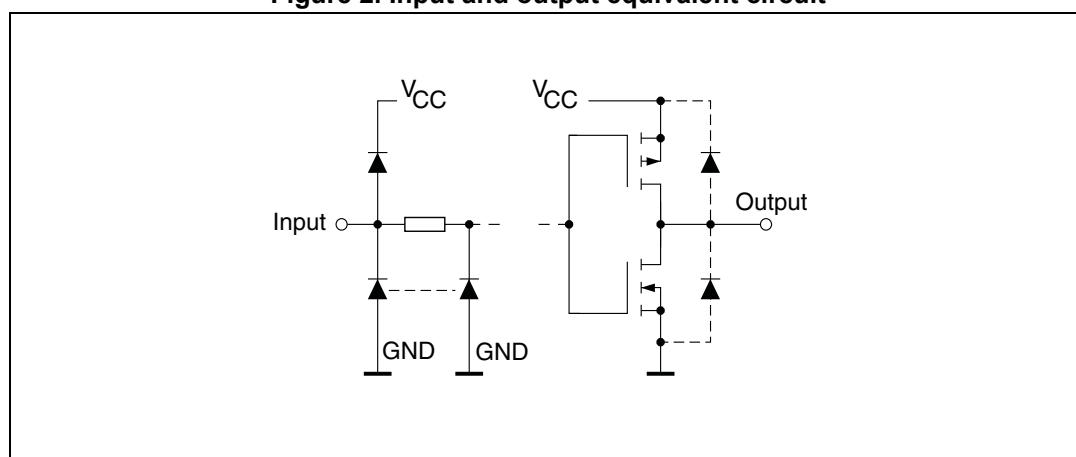

3 Electrical characteristics

“Absolute maximum ratings” are those values beyond which damage to the device may occur. Functional operation under these conditions is not implied.

Table 4. Absolute maximum ratings

Symbol	Parameter	Value	Unit
V_{CC}	Supply voltage	-0.5 to +7	V
V_I	DC input voltage	-0.5 to $V_{CC} + 0.5$	
V_O	DC output voltage		
I_{IK}	DC input diode current	± 20	mA
I_{OK}	DC output diode current		
I_O	DC output current	± 35	
I_{CC} or I_{GND}	DC V_{CC} or ground current	± 70	
P_D	Power dissipation	500 ⁽¹⁾	mW
T_{stg}	Storage temperature	-65 to +150	°C
T_L	Lead temperature (10 sec)	300	

1. 500 mW at 65 °C; derate to 300 mW by 10 mW/°C from 65 °C to 85 °C

Table 5. Recommended operating conditions

Symbol	Parameter	Value	Unit	
V_{CC}	Supply voltage	2 to 6	V	
V_I	Input voltage	0 to V_{CC}		
V_O	Output voltage			
T_{op}	Operating temperature	-55 to 125	°C	
t_r, t_f	Input rise and fall time	$V_{CC} = 2.0\text{ V}$	0 to 1000	ns
		$V_{CC} = 4.5\text{ V}$	0 to 500	
		$V_{CC} = 6.0\text{ V}$	0 to 400	

Table 6. DC specifications

Symbol	Parameter	Test condition		Value						Unit	
		V _{CC} (V)		T _A = 25 °C			-40 to 85 °C		-55 to 125 °C		
				Min.	Typ.	Max.	Min.	Max.	Min.		Max.
V _{IH}	High level input voltage	2.0		1.5			1.5		1.5		V
		4.5		3.15			3.15		3.15		
		6.0		4.2			4.2		4.2		
V _{IL}	Low level input voltage	2.0				0.5		0.5		0.5	V
		4.5				1.35		1.35		1.35	
		6.0				1.8		1.8		1.8	
V _{OH}	High level output voltage	2.0	I _O = -20 μA	1.9	2.0		1.9		1.9		V
		4.5	I _O = -20 μA	4.4	4.5		4.4		4.4		
		6.0	I _O = -20 μA	5.9	6.0		5.9		5.9		
		4.5	I _O = -6.0 mA	4.18	4.31		4.13		4.10		
		6.0	I _O = -7.8 mA	5.68	5.8		5.63		5.60		
V _{OL}	Low level output voltage	2.0	I _O = 20 μA		0.0	0.1		0.1		0.1	V
		4.5	I _O = 20 μA		0.0	0.1		0.1		0.1	
		6.0	I _O = 20 μA		0.0	0.1		0.1		0.1	
		4.5	I _O = 6.0 mA		0.17	0.26		0.33		0.40	
		6.0	I _O = 7.8 mA		0.18	0.26		0.33		0.40	
I _I	Input leakage current	6.0	V _I = V _{CC} or GND			±0.1		±1		±1	μA
I _{OZ}	High impedance output leakage current	6.0	V _I = V _{IH} or V _{IL} V _O = V _{CC} or GND			±0.5		±5		±10	μA
I _{CC}	Quiescent supply current	6.0	V _I = V _{CC} or GND			4		40		80	μA

Table 7. AC electrical characteristics
(Input $t_r = t_f = 6$ ns)

Symbol	Parameter	Test condition			Value								Unit
		V_{CC} (V)	C_L (pF)		$T_A = 25\text{ °C}$			$-40\text{ to }85\text{ °C}$		$-55\text{ to }125\text{ °C}$			
					Min.	Typ.	Max.	Min.	Max.	Min.	Max.		
t_{TLH}, t_{THL}	Output transition time	2.0	50			20	60		75		90	ns	
		4.5			6	12		15		18			
		6.0			5	10		13		15			
t_{PLH}, t_{PHL}	Propagation delay time	2.0	50			36	75		95		110	ns	
		4.5			9	15		19		22			
		6.0			8	13		16		19			
		2.0	150			52	105		130		160	ns	
		4.5			13	21		26		32			
		6.0			11	18		22		27			
t_{PZL}, t_{PZH}	High impedance output enable time	2.0	50	$R_L = 1\text{ k}\Omega$			36	75		95		110	ns
		4.5				9	15		19		22		
		6.0				8	13		16		19		
		2.0	150				52	105		130		160	ns
		4.5				13	21		26		32		
		6.0				11	18		22		27		
t_{PLZ}, t_{PHZ}	High impedance output disable time	2.0	50	$R_L = 1\text{ k}\Omega$			48	80		100		120	ns
		4.5				12	16		20		24		
		6.0				10	14		17		20		

Table 8. Capacitive characteristics

Sym	Parameter	Test condition	Value								Unit
		V_{CC} (V)	$T_A = 25\text{ °C}$			$-40\text{ to }85\text{ °C}$		$-55\text{ to }125\text{ °C}$			
			Min	Typ	Max	Min	Max	Min	Max		
C_{IN}	Input capacitance	5.0	-	5	10	-	10	-	10	pF	
C_{PD}	Power dissipation capacitance ⁽¹⁾		-	35	-	-	-	-			

1. C_{PD} is defined as the value of the IC's internal equivalent capacitance which is calculated from the operating current consumption without load (refer to test circuit). Average operating current can be obtained by the following equation:
 $I_{CC(opr)} = C_{PD} \times V_{CC} \times f_{IN} + I_{CC}/4$ (per buffer).

Figure 3. Test circuit

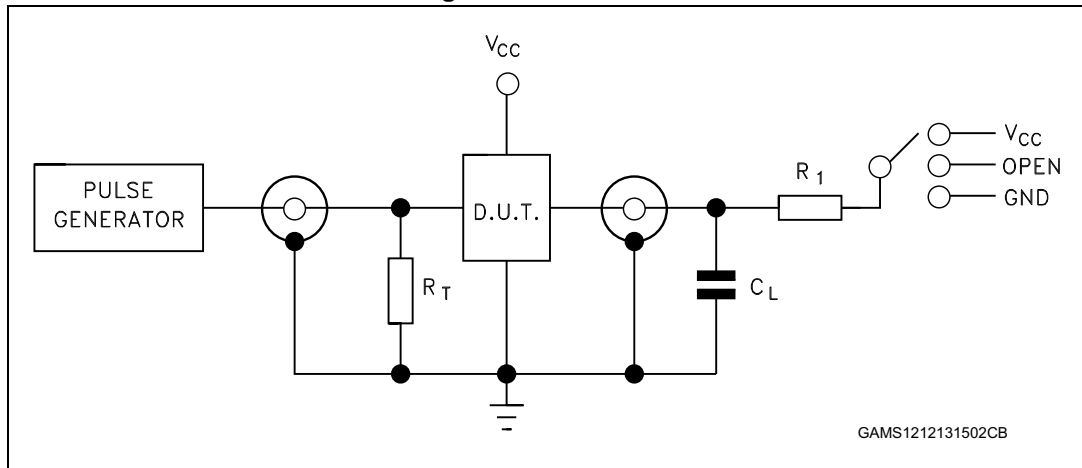

1. Legend:
 $C_L = 50 \text{ pF}/150 \text{ pF}$ or equivalent (includes jig and probe capacitance).
 $R_1 = 1 \text{ k}\Omega$ or equivalent.
 $R_T = Z_{OUT}$ of pulse generator (typically 50Ω).

Table 9. Propagation delay time configuration

Test	Switch
t_{PLH}, t_{PHL}	Open
t_{PZL}, t_{PLZ}	V_{CC}
t_{PZH}, t_{PHZ}	GND

Figure 4. Waveform 1: propagation delay times
(f = 1 MHz; 50 % duty cycle)

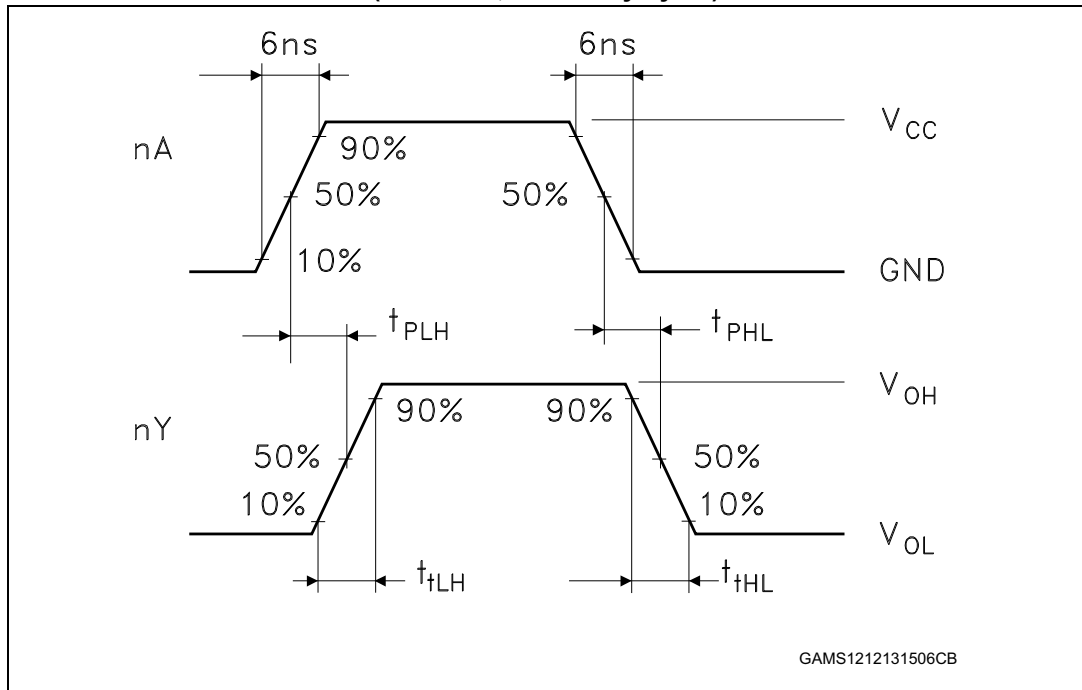
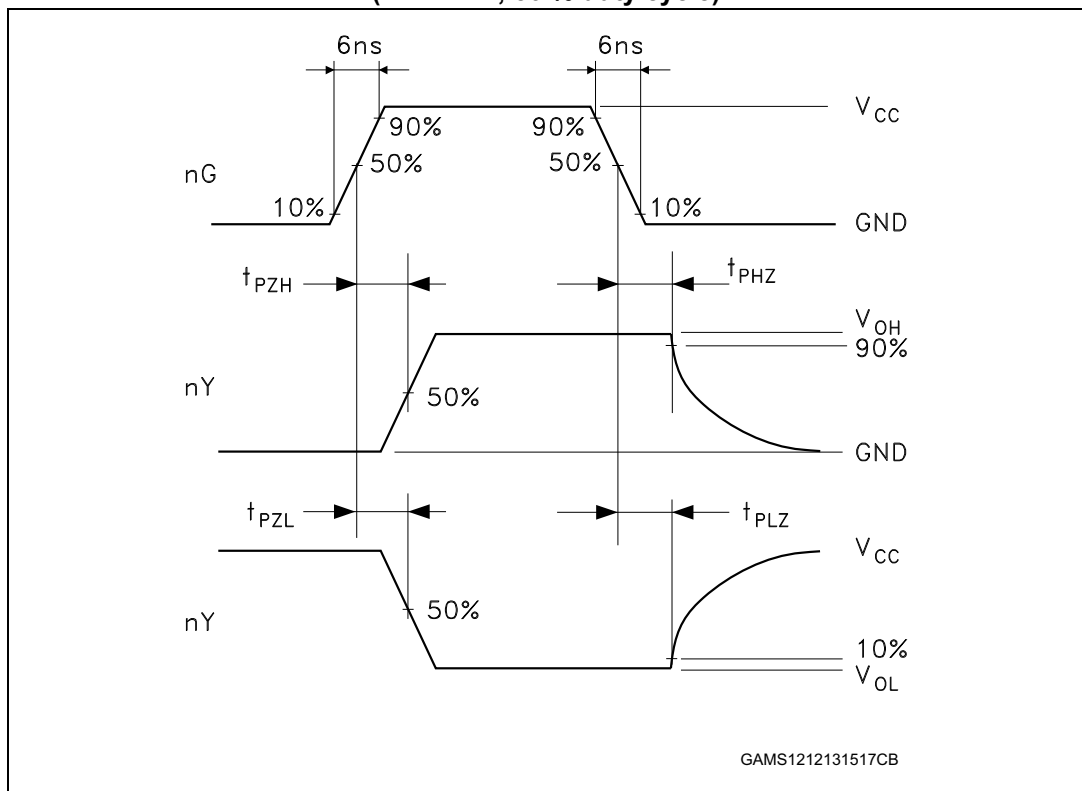

Figure 5. Waveform 2: Output enable and disable times
(f = 1 MHz; 50 % duty cycle)



4 Package information

In order to meet environmental requirements, ST offers these devices in different grades of ECOPACK[®] packages, depending on their level of environmental compliance. ECOPACK[®] specifications, grade definitions and product status are available at: www.st.com. ECOPACK[®] is an ST trademark.

4.1 SO14 package information

Figure 6. SO14 package mechanical drawing

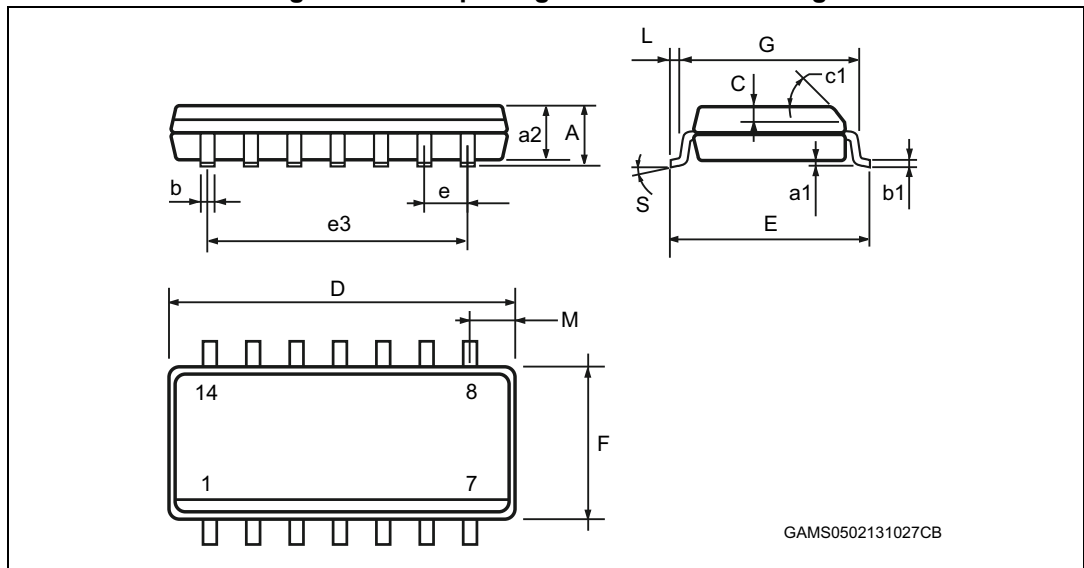

Table 10. SO14 package mechanical data

Ref	Dimensions					
	Millimeters			Inches		
	Min.	Typ.	Max.	Min.	Typ.	Max.
A			1.75			0.068
a1	0.1		0.2	0.003		0.007
a2			1.65			0.064
b	0.35		0.46	0.013		0.018
b1	0.19		0.25	0.007		0.010
C		0.5			0.019	
c1		45 °			45 °	
D	8.55		8.75	0.336		0.344
E	5.8		6.2	0.228		0.244
e		1.27			0.050	
e3		7.62			0.300	
F	3.8		4.0	0.149		0.157
G	4.6		5.3	0.181		0.208
L	0.5		1.27	0.019		0.050
M			0.68			0.026
S			8 °			8 °

4.2 TSSOP14 package information

Figure 7. TSSOP14 package mechanical drawing

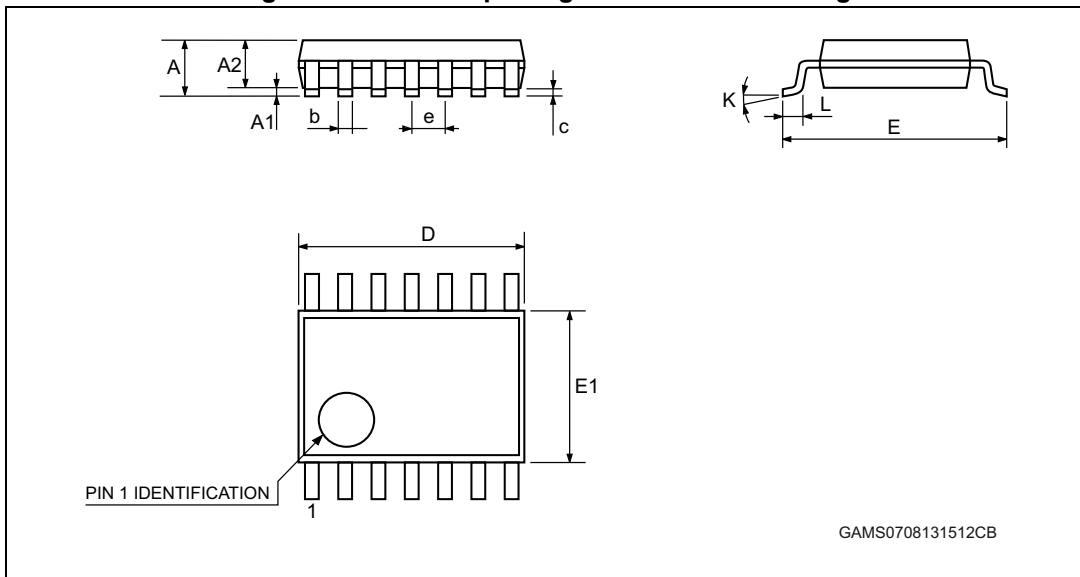

Table 11. TSSOP14 package mechanical data

Ref	Dimensions					
	Millimeters			Inches		
	Min.	Typ.	Max.	Min.	Typ.	Max.
A			1.2			0.047
A1	0.05		0.15	0.002	0.004	0.006
A2	0.8	1	1.05	0.031	0.039	0.041
b	0.19		0.30	0.007		0.012
c	0.09		0.20	0.004		0.0089
D	4.9	5	5.1	0.193	0.197	0.201
E	6.2	6.4	6.6	0.244	0.252	0.260
E1	4.3	4.4	4.48	0.169	0.173	0.176
e		0.65			0.0256	
K	0 °		8 °	0 °		8 °
L	0.45	0.60	0.75	0.018	0.024	0.030

5 Ordering information

Table 12. Order codes

Order code	Temp. range	Package	Packaging	Marking
M74HC126RM13TR	-55 °C to 125 °C	S014	Tape and reel	74HC126
M74HC126YRM13TR ⁽¹⁾	-40 °C to 125 °C	SO14 (automotive grade)		74HC126Y
M74HC126TTR	-55 °C to 125 °C	TSSOP14		HC126
M74HC126YTTR ⁽¹⁾	-40 °C to 125 °C	TSSOP14 (automotive grade)		HC126Y

1. Qualification and characterization according to AEC Q100 and Q003 or equivalent, advanced screening according to AEC Q001 and Q002 or equivalent.

6 Revision history

Table 13. Document revision history

Date	Revision	Changes
Aug-2001	1	Initial release.
13-Dec-2013	3	Removed DIP14 package <i>Features</i> : added ESD information <i>Table 1: Device summary</i> : updated order codes, added automotive grade order codes, added temperature range and marking details. Added <i>Section 5: Ordering information</i> .