

Double-Balanced Mixer

Rev. V3

Features

- LO 5 TO 18 GHz
- RF 7 TO 18 GHz
- IF DC TO 3000 MHz
- LO DRIVE: +10 dBm (NOMINAL)
- WIDE BANDWIDTH
- LOW NOISE FIGURE

Description

The M79 is a double balanced mixer, designed for use in military, commercial and test equipment applications. This mixer can also be used as a phase detector or bi-phase modulator since the IF port is DC coupled to the diodes. Environmental screening available to MIL-STD-202, and MIL-DTL-28837, consult factory.

Product Image

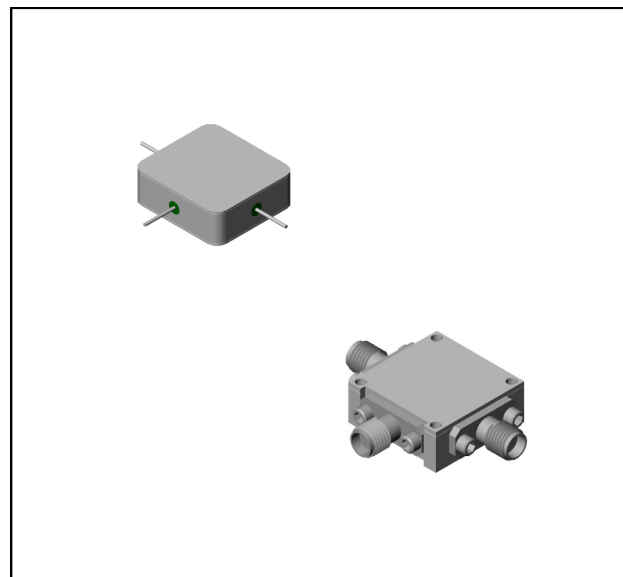

Ordering Information

Part Number	Package
M79	Minpac
M79C	SMA Connectorized

Electrical Specifications: $Z_0 = 50\Omega$ $Lo = +10$ dBm (Downconverter application only)

Parameter	Test Conditions	Units	Typical	Guaranteed	
				+25°C	-54° to +85°C
SSB Conversion Loss (max) & SSB Noise Figure (max)	fR = 7 to 16 GHz, fL = 6 to 17 GHz, fl = 30 to 1000 MHz	dB	5.7	7.5	8.0
	fR = 7 to 16 GHz, fL = 5 to 18 GHz, fl = 30 to 2000 MHz	dB	6.0	8.0	8.5
	fR = 8 to 16 GHz, fL = 5 to 16 GHz, fl = 30 to 3000 MHz	dB	6.0	8.0	8.5
	fR = 16 to 18 GHz, fL = 13 to 18 GHz, fl = 30 to 3000 MHz	dB	7.0	9.0	9.5
Isolation, L to R (min)	fL = 5 to 14 GHz	dB	35	22	20
	fL = 14 to 18 GHz	dB	33	15	13
Isolation, L to I (min)	fL = 5 to 8 GHz	dB	34	22	20
	fL = 8 to 18 GHz	dB	24	12	10
1 dB Conversion Comp.	fL = +10 dBm	dBm	+4		
Input IP3	fR1=13 GHz at -6 dBm, fR2=13.01GHz at -6 dBm, fL = 14 GHz at = 10 dBm	dBm	+14		

Double-Balanced Mixer

Rev. V3

Absolute Maximum Ratings

Parameter	Absolute Maximum
Operating Temperature	-54°C to +100°C
Storage Temperature	-65°C to +100°C
Peak Input Power	+23 dBm max @ +25°C +20 dBm max @ +85°C
Peak Input Current	100 mA DC

Typical Performance Curves

Conversion Loss vs. Input Power and Temperature

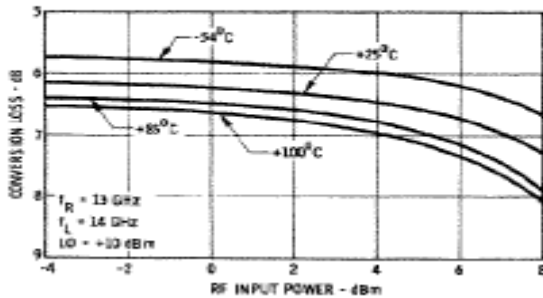

Conversion Loss vs. Frequency

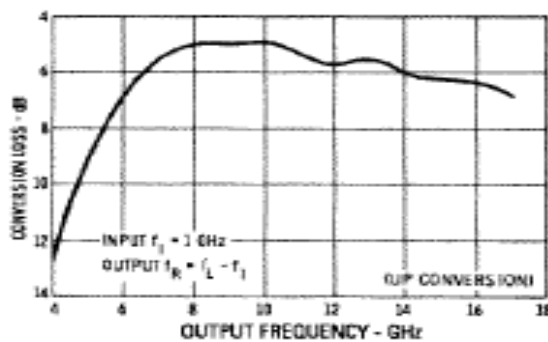

Outline Drawing: Minpac *

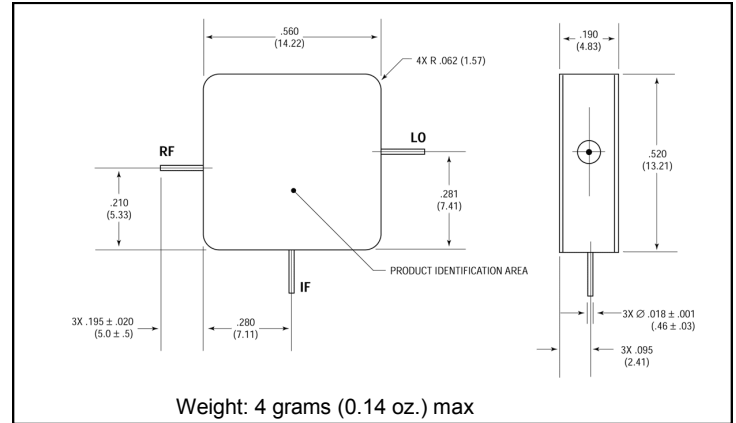

Outline Drawing: SMA Connectorized *

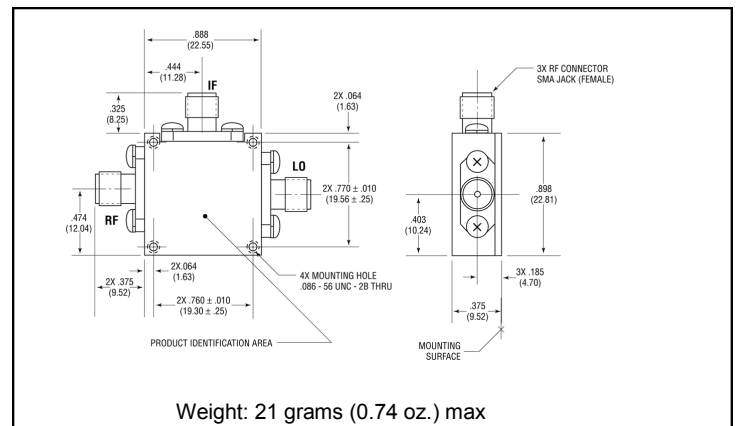

* Dimensions are inches (millimeters) ±0.015 (0.38) unless otherwise specified.

Conversion Loss vs. LO Drive Power.

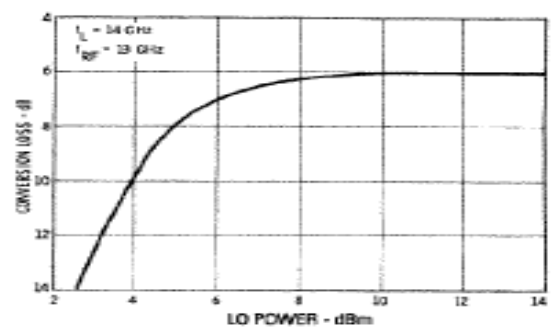

Typical Performance Curves

Isolation

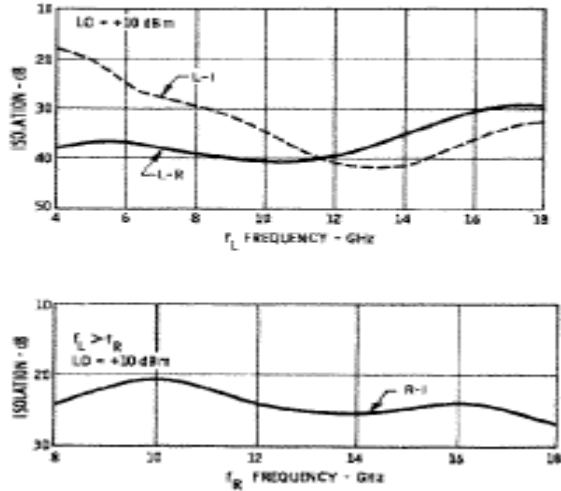

Conversion Loss vs. Frequency.

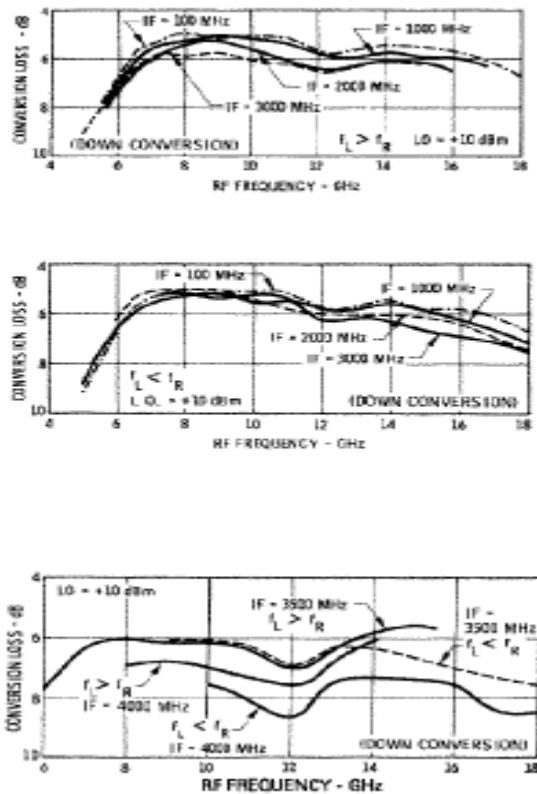

L-Port VSWR

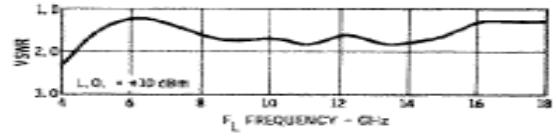

R-Port VSWR

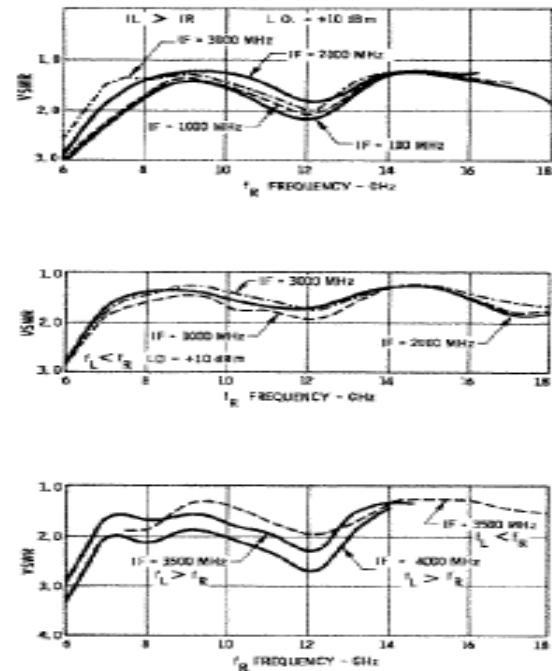

I-Port VSWR

