

Double-Balanced Mixer

Rev. V3

Features

- LO 5 TO 18 GHz
- RF 7 TO 18 GHz
- IF DC TO 3000 MHz
- LO DRIVE: +20 dBm (NOMINAL)
- HIGH THIRD-ORDER I.P. +24 dBm (TYP.)

Description

The M79H is a double balanced mixer, designed for use in military, commercial and test equipment applications. This mixer can also be used as a phase detector or bi-phase modulator since the IF port is DC coupled to the diodes. Environmental screening available to MIL-STD-202, and MIL-DTL-28837, consult factory.

Product Image

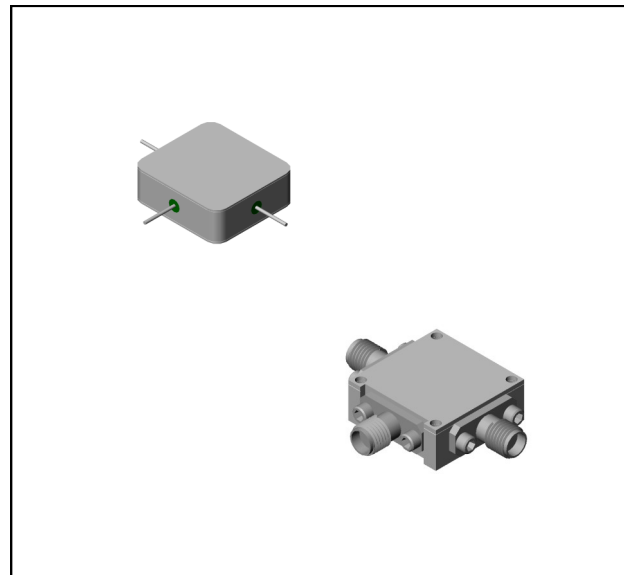

Ordering Information

Part Number	Package
M79H	Minpac
M79HC	SMA Connectorized

Electrical Specifications: $Z_0 = 50\Omega$ $Lo = +20$ dBm (Downconverter application only)

Parameter	Test Conditions	Units	Typical	Guaranteed	
				+25°C	-54° to +85°C
SSB Conversion Loss (max) & SSB Noise Figure (max)	fR = 7 to 15 GHz, fL = 6 to 15 GHz, fl = 30 to 1000 MHz	dB	6.5	8.0	8.3
	fR = 7 to 16 GHz, fL = 5 to 18 GHz, fl = 30 to 2000 MHz	dB	7.0	8.5	8.8
	fR = 7 to 16 GHz, fL = 5 to 18 GHz, fl = 30 to 3000 MHz	dB	7.5	9.5	9.8
	fR = 16 to 18 GHz, fL = 5 to 15 GHz, fl = 30 to 3000 MHz	dB	8.5	10.0	10.3
Isolation, L to R (min)	fL = 5 to 14 GHz	dB	35	23	22
	fL = 14 to 18 GHz	dB	30	20	19
Isolation, L to I (min)	fL = 5 to 9 GHz	dB	27	17	16
	fL = 9 to 18 GHz	dB	35	25	24
1 dB Conversion Comp.	fL = +20 dBm	dBm	+15		
Input IP3	fR1=13 GHz at 0 dBm, fR2=13.01GHz at 0 dBm, fL = 14 GHz at = 20 dBm	dBm	+24		

M79H / M79HC



Double-Balanced Mixer

Rev. V3

Absolute Maximum Ratings

Parameter	Absolute Maximum
Operating Temperature	-54°C to +100°C
Storage Temperature	-65°C to +100°C
Peak Input Power	+25 dBm max @ +25°C +21 dBm max @ +85°C
Peak Input Current	100 mA DC

Outline Drawing: Minpac *

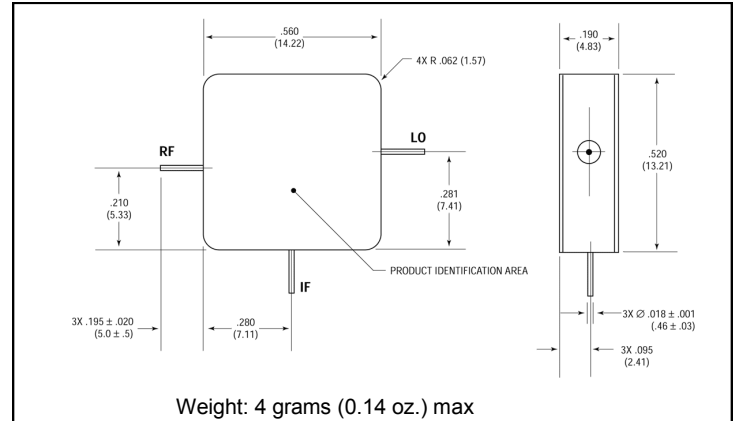

Outline Drawing: SMA Connectorized *

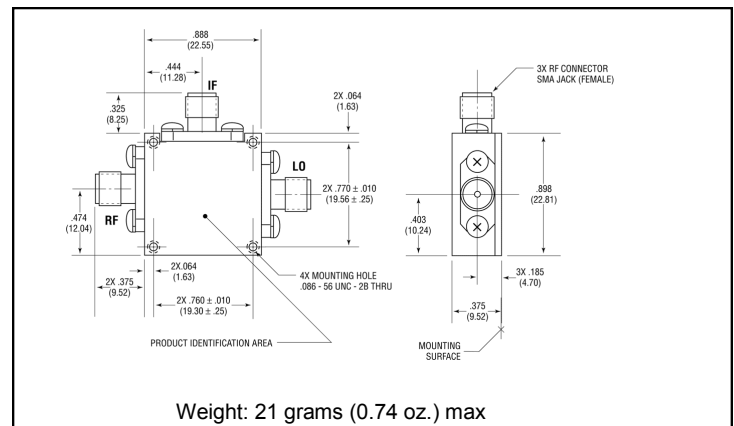

* Dimensions are inches (millimeters) ±0.015 (0.38) unless otherwise specified.