

Double-Balanced Mixer

Rev. V4

Features

- LO 2 to 18 GHz
- RF 2 to 18 GHz
- IF 0 to 1000 MHz
- LO Drive: +7 dBm (Nominal)
- DC Coupled I-Port
- Wide Bandwidth

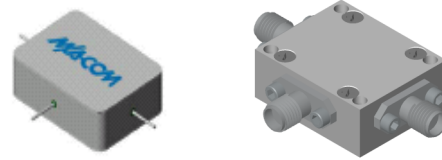

Description

The M85 is a double balanced mixer, designed for use in military, commercial and test equipment applications. The design utilizes Schottky ring quad diodes and broadband soft dielectric and ferrite baluns to attain excellent performance. This mixer can also be used as a phase detector and/or bi-phase modulator since the IF port is DC coupled to the diodes. The use of high temperature solder and welded assembly processes used internally makes it ideal for use in manual, semi-automated assembly. Environmental screening available to MIL-STD-883, MIL-STD-202, or MIL-DTL-28837, consult factory.

Ordering Information

Part Number	Package
M85	Minpac
M85C	SMA Connectorized

Electrical Specifications: $Z_0 = 50 \Omega$ $Lo = +7$ dBm (Downconverter application only)

Parameter	Test Conditions	Units	Typ.	Guaranteed	
				+25°C	-54° to +85°C
SSB Conversion Loss & SSB Noise Figure (max.)	fR = 4 to 14 GHz, fL = 3 to 15 GHz, fI = 0 to 1 GHz fR = 2 to 3 GHz, fL = 2 to 3 GHz, fI = 0 to 1 GHz fR = 3 to 18 GHz, fL = 3 to 18 GHz, fI = 0 to 1 GHz	dB	7.0 10.0 8.5	9.0 11.0 10.5	9.5 11.5 11.0
Isolation, L to R (min.)	fL = 2 to 18 GHz	dB	35	22	20
Isolation, L to I (min.)	fL = 2 to 18 GHz	dB	20	15	13
Isolation, R to I (min.)	fL = 2 to 18 GHz	dB	20	—	—
1 dB Conversion Comp.	fL = +7 dBm	dBm	+1	—	—
Input IP3	fR1 = 5.00 GHz @ -10 dBm, fR2 = 5.01 GHz @ -10 dBm, fL = 5.50 GHz @ +7 dBm fR1 = 15.00 GHz @ -10 dBm, fR2 = 15.01 GHz @ -10 dBm, fL = 14.50 GHz @ +7 dBm	dBm	+10 +10	—	—

Absolute Maximum Ratings

Parameter	Absolute Maximum
Operating Temperature	-54°C to +100°C
Storage Temperature	-65°C to +100°C
Peak Input Power	+23 dBm @ +25°C +20 dBm @ +100°C
Peak Input Current	100 mA DC

Typical Performance Curves

VSWR

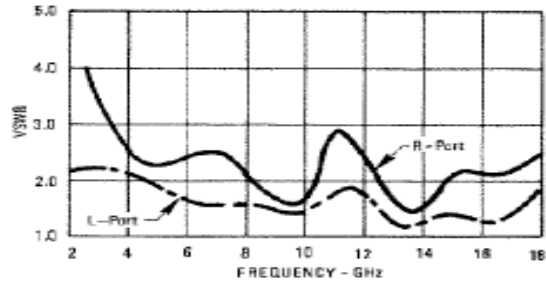

Isolation

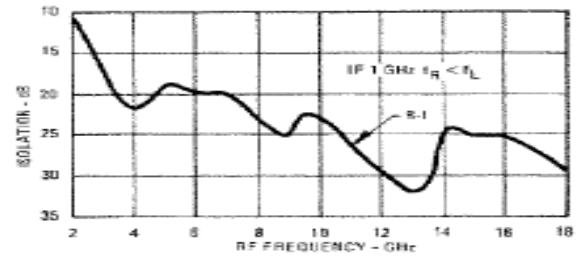
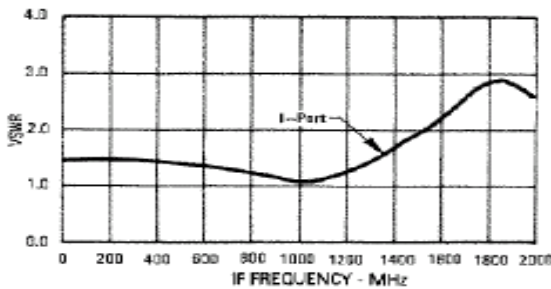
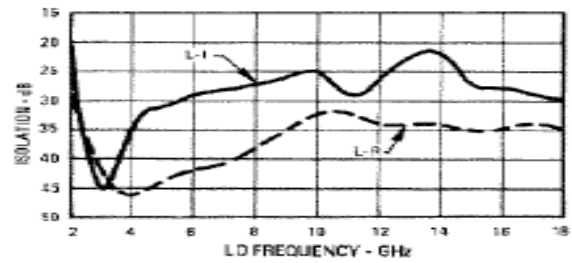

Double-Balanced Mixer

Rev. V4

Typical Performance Curves

Conversion Loss vs LO Power Level

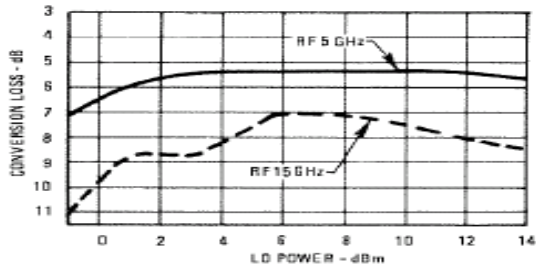

Up Conversion Loss

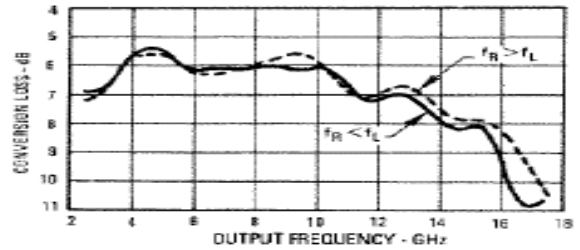

Conversion Loss

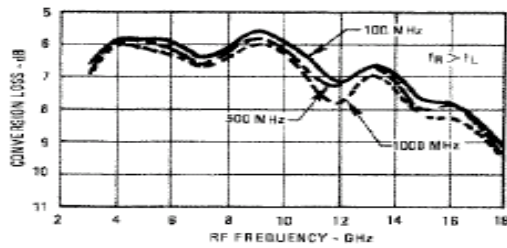

I Port Bandwidth

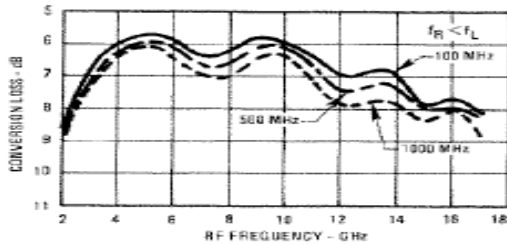
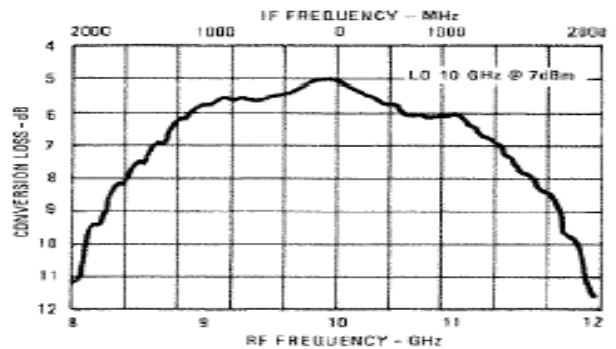

Insertion Loss with DC Driven I-Port

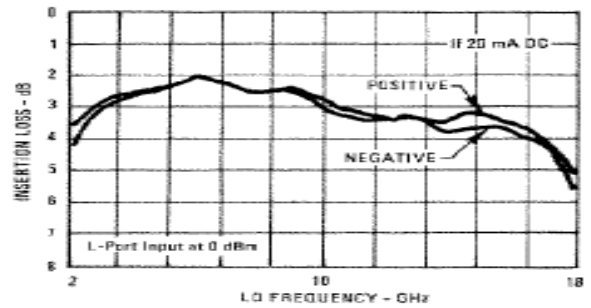

Conversion Loss over Temperature

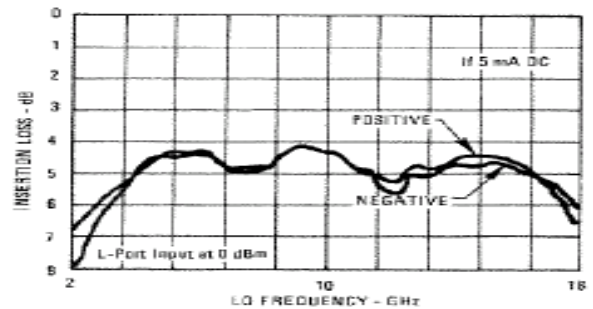
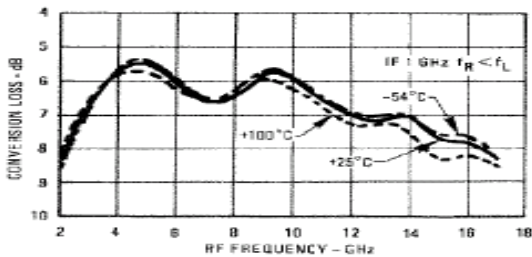

Outline Drawing: Minpac*

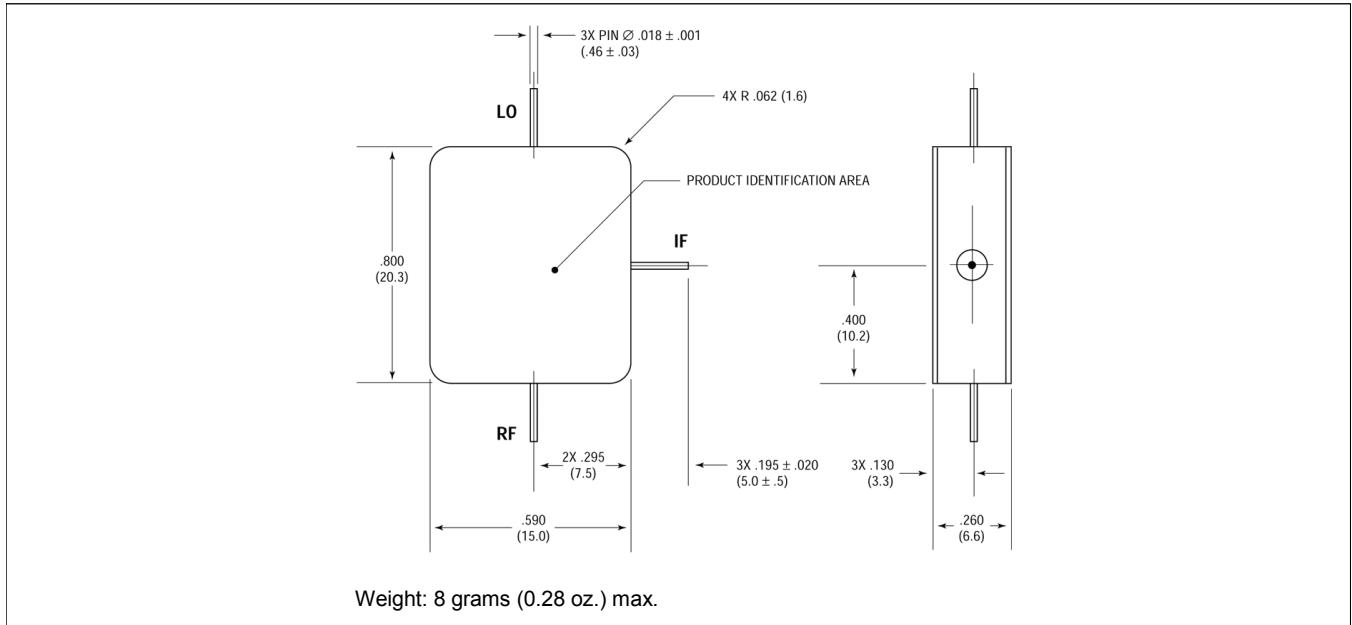

Outline Drawing: SMA Connectorized*

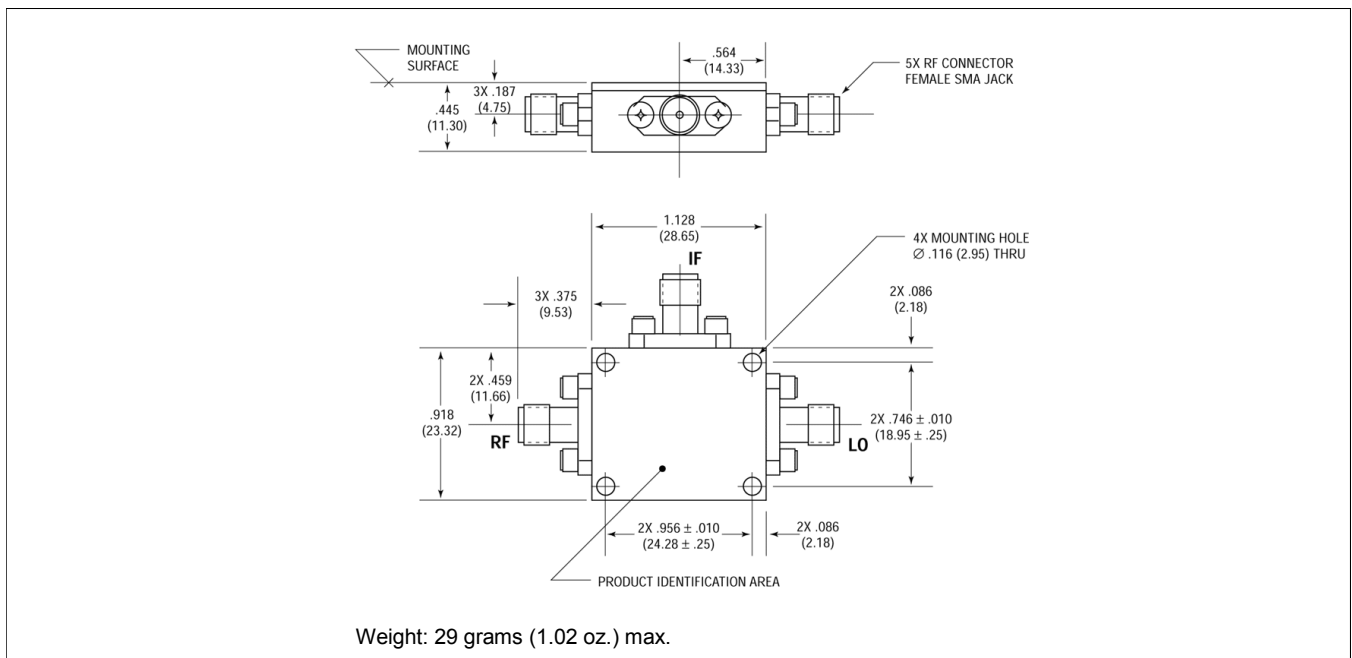

* Dimensions are inches (millimeters) ± 0.015 (0.38) unless otherwise specified.