



MICROCHIP

dsPIC33FJ32MC204

dsPIC33FJ32MC204 PIM Information Sheet

The dsPIC33FJ32MC204 PIM is designed to demonstrate the capabilities of the dsPIC33FJ32MC204 family of general purpose devices using the Explorer 16 Development Board and the PICtail™ Plus daughter boards.

The dsPIC33FJ32MC204 is a high-performance 16-bit digital signal controller within a small 44-pin QFN package.

The dsPIC33FJ32MC204 is equipped with Peripheral Pin Select (PPS), which allows many of the digital peripherals to be remapped to use any number of pins on the device.

The PIM takes advantage of PPS by using zero ohm resistors to connect the I/O to the 100-pin Explorer 16 Development Board. Simply removing the zero ohm resistors and using the test points associated with each I/O pin (i.e., Pin1, Pin2, etc.), allows the designer to reroute the pin to any of the available pins on the Explorer 16 Development Board. This capability enables easier and faster design times.

Table 1 shows the mapping between the Explorer 16 functions and the device pins.

TABLE 1: 44-PIN TO 100-PIN PINOUT

Device Pin Number	dsPIC33FJ32MC204	PIM Pin Number	Functional Description
1	SDA1/RP9/CN21/RB9	19	Fault Reset
2	PWM2H1/RP22/CN18/RC6	77	Data 2
3	INT0/RP23/CN23/RB7	78	Data 3
4	TCK/PWM2H1/SCL1/RP24/CN22/RB8	68, 20	Hall Sensor A/ QEB_POT
5	TDO/PWM2L1/SDA1/RP25/CN21/RB9	69, 21	Hall Sensor B/ QEA
6	Vss	65	
7	VCAP/VDDCORE	85	
8	TDI/PWM1H3/RP10/CN16/RB10	3	PWM1H3
9	TMS/PWM1L3/RP11/CN15/RB11	100	PWM1L3
10	PWM1H2/RP12/CN14/RB12	99	PWM1H2
11	PWM1L2/RP13/CN13/RB13	98	PWM1L2
12	TMS/RA10		
13	TCK/RA7	71	PWM Enable
14	PWM1H1/RP14/CN12/RB14	94	PWM1H1
15	PWM1L1/RP15/CN11/RB15	93	PWM1L1
16	AVss	31	
17	AVDD	30	
18	MCLR	13	
19	AN0/VREF+/CN2/RA0	25	Phase 1 Current Feedback
20	AN1/VREF-/CN3/RA1	24	Phase 2 Current Feedback
21	PGED1/EMUD1/AN2/C2IN-/RP0/CN4/RB0	35	DC Bus
22	PGEC1/EMUC1/AN3/C2IN+/RP1/CN5/RB1	41	Phase 1 Voltage Feedback

Device Pin Number	dsPIC33FJ32MC204	PIM Pin Number	Functional Description
23	AN4/RP2/CN6/RB2	42	Phase 2 Voltage Feedback
24	AN5/RP3/CN7/RB3	43	Phase 3 Voltage Feedback
25	AN6/RP16/CN8/RC0		
26	AN7/RP17/CN9/RC1	20	QEB_POT
27	AN8/RP18/CN10/RC2	32	Bus Shunt
28	VDD	16	
29	Vss	15	
30	OSCI/CLKI/CN30/RA2	63	OSC1
31	OSCO/CLKO/CN29/RA3	64	OSC2
32	TDO/RA8	83	Switch 1
33	SOSCI/RP4/CN1/RB4	84	Switch 2
34	SOSCO/T1CK/CN0/RA4	81	Enable
35	TDI/RA9	82	RD/WR
36	RP19/CN28/RC3	44	RS
37	RP20/CN25/RC4	72	Data 0
38	RP21/CN26/RC5	76	Data 1
39	Vss	36	
40	VDD	37	
41	PGED3/EMUD3/ASDA1/RP5/CN27/RB5	27	Debug
42	PGEC3/EMUC3/ASCL1/RP6/CN24/RB6	26	Debug
43	INT0/RP7/CN23/RB7	22, 70	Index/Hall Sensor C
44	SCL1/RP8/CN22/RB8	18	Fault A

dsPIC33FJ32MC204

FIGURE 1: 100-PIN HEADER SCHEMATIC

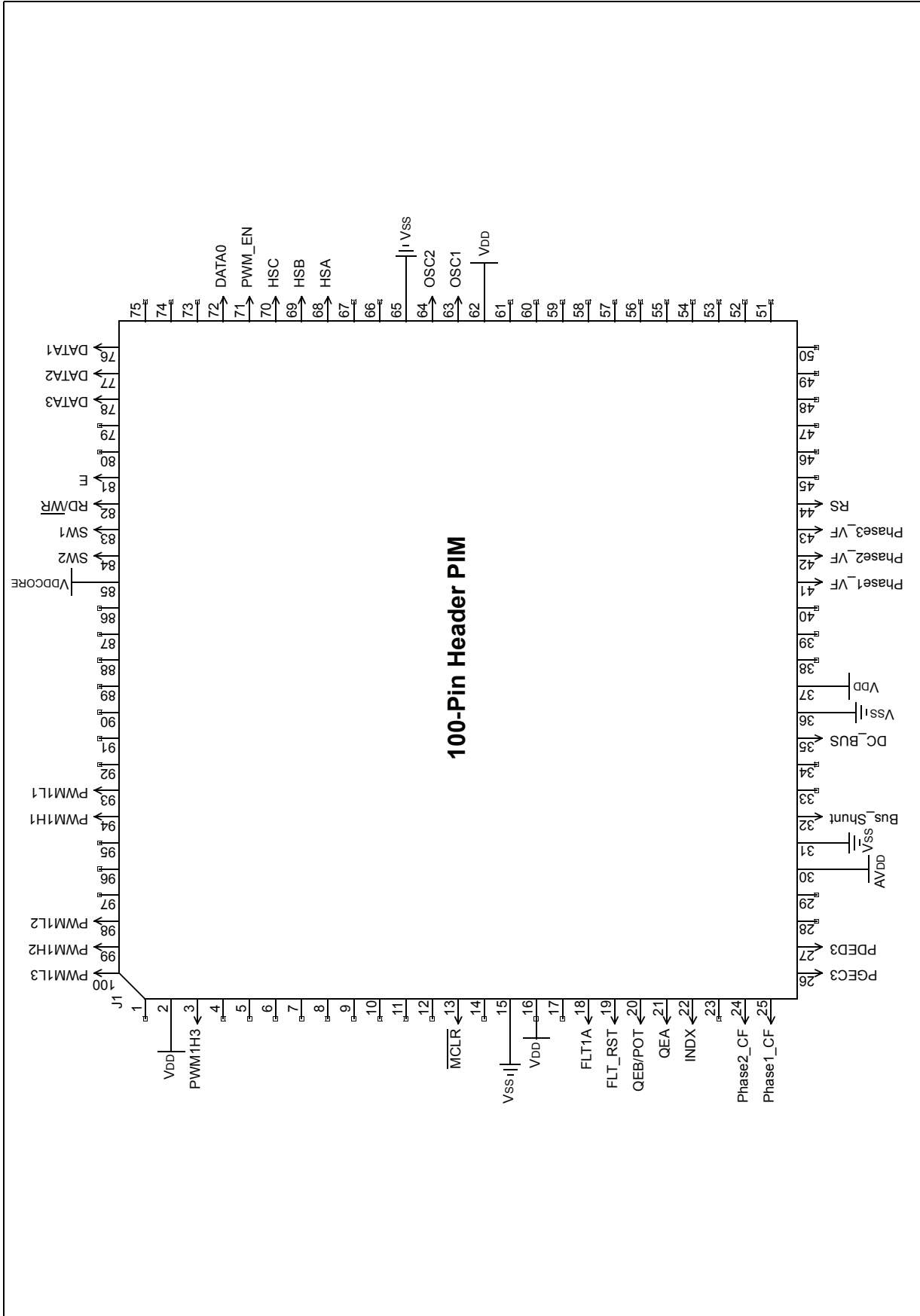
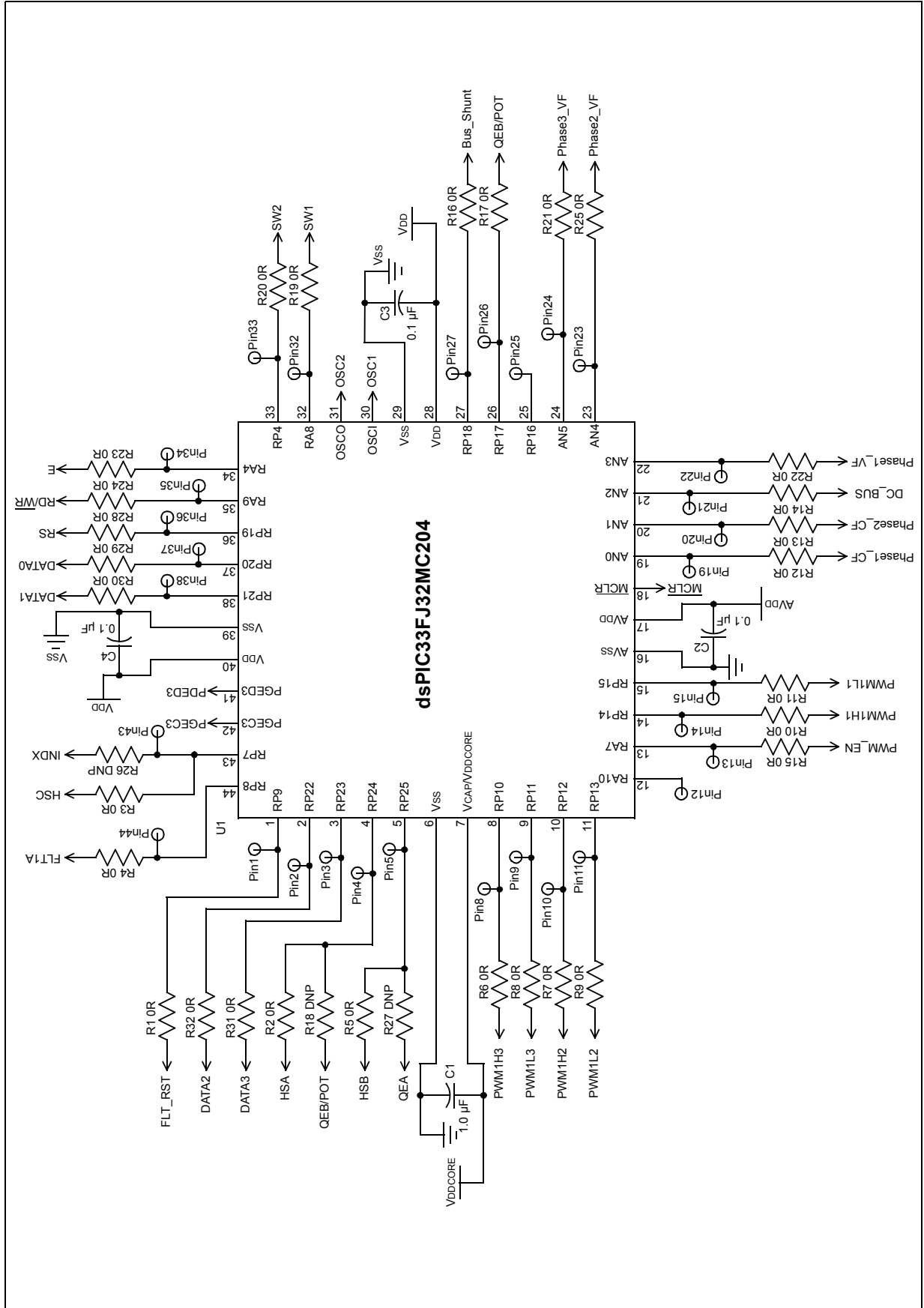

FIGURE 2: 44-PIN DEVICE SCHEMATIC



dsPIC33FJ32MC204

NOTES:

Note the following details of the code protection feature on Microchip devices:

- Microchip products meet the specification contained in their particular Microchip Data Sheet.
- Microchip believes that its family of products is one of the most secure families of its kind on the market today, when used in the intended manner and under normal conditions.
- There are dishonest and possibly illegal methods used to breach the code protection feature. All of these methods, to our knowledge, require using the Microchip products in a manner outside the operating specifications contained in Microchip's Data Sheets. Most likely, the person doing so is engaged in theft of intellectual property.
- Microchip is willing to work with the customer who is concerned about the integrity of their code.
- Neither Microchip nor any other semiconductor manufacturer can guarantee the security of their code. Code protection does not mean that we are guaranteeing the product as "unbreakable."

Code protection is constantly evolving. We at Microchip are committed to continuously improving the code protection features of our products. Attempts to break Microchip's code protection feature may be a violation of the Digital Millennium Copyright Act. If such acts allow unauthorized access to your software or other copyrighted work, you may have a right to sue for relief under that Act.

Information contained in this publication regarding device applications and the like is provided only for your convenience and may be superseded by updates. It is your responsibility to ensure that your application meets with your specifications. MICROCHIP MAKES NO REPRESENTATIONS OR WARRANTIES OF ANY KIND WHETHER EXPRESS OR IMPLIED, WRITTEN OR ORAL, STATUTORY OR OTHERWISE, RELATED TO THE INFORMATION, INCLUDING BUT NOT LIMITED TO ITS CONDITION, QUALITY, PERFORMANCE, MERCHANTABILITY OR FITNESS FOR PURPOSE. Microchip disclaims all liability arising from this information and its use. Use of Microchip devices in life support and/or safety applications is entirely at the buyer's risk, and the buyer agrees to defend, indemnify and hold harmless Microchip from any and all damages, claims, suits, or expenses resulting from such use. No licenses are conveyed, implicitly or otherwise, under any Microchip intellectual property rights.

Trademarks

The Microchip name and logo, the Microchip logo, Accuron, dsPIC, KEELOQ, KEELOQ logo, microID, MPLAB, PIC, PICmicro, PICSTART, PRO MATE, rPIC and SmartShunt are registered trademarks of Microchip Technology Incorporated in the U.S.A. and other countries.

AmpLab, FilterLab, Linear Active Thermistor, Migratable Memory, MXDEV, MXLAB, SEEVAL, SmartSensor and The Embedded Control Solutions Company are registered trademarks of Microchip Technology Incorporated in the U.S.A.

Analog-for-the-Digital Age, Application Maestro, CodeGuard, dsPICDEM, dsPICDEM.net, dsPICworks, dsSPEAK, ECAN, ECONOMONITOR, FanSense, FlexROM, fuzzyLAB, In-Circuit Serial Programming, ICSP, ICEPIC, Mindi, MiWi, MPASM, MPLAB Certified logo, MPLIB, MPLINK, PICkit, PICDEM, PICDEM.net, PICLAB, PICtail, PowerCal, PowerInfo, PowerMate, PowerTool, REAL ICE, rLAB, Select Mode, Smart Serial, SmartTel, Total Endurance, UNI/O, WiperLock and ZENA are trademarks of Microchip Technology Incorporated in the U.S.A. and other countries.

SQTP is a service mark of Microchip Technology Incorporated in the U.S.A.

All other trademarks mentioned herein are property of their respective companies.

© 2007, Microchip Technology Incorporated, Printed in the U.S.A., All Rights Reserved.

 Printed on recycled paper.

**QUALITY MANAGEMENT SYSTEM
CERTIFIED BY DNV
== ISO/TS 16949:2002 ==**

Microchip received ISO/TS-16949:2002 certification for its worldwide headquarters, design and wafer fabrication facilities in Chandler and Tempe, Arizona; Gresham, Oregon and design centers in California and India. The Company's quality system processes and procedures are for its PIC® MCUs and dsPIC® DSCs, KEELOQ® code hopping devices, Serial EEPROMs, microperipherals, nonvolatile memory and analog products. In addition, Microchip's quality system for the design and manufacture of development systems is ISO 9001:2000 certified.